



FLUVANNA COUNTY BOARD OF SUPERVISORS MEETING AGENDA

Circuit Courtroom, Fluvanna Courts Building
November 15, 2016 - 7:00 pm

TAB AGENDA ITEMS

1 – CALL TO ORDER

2 – PLEDGE OF ALLEGIANCE AND MOMENT OF SILENCE

3 – ADOPTION OF AGENDA

SPECIAL ACTION ITEM AND PRESENTATION

P Community Service Award Resolution Recognizing Dr. Robert Mayfield – Steve Nichols, County Administrator

Presentation of Community Service Award Resolution

4 – COUNTY ADMINISTRATOR'S REPORT

5 – PUBLIC COMMENTS #1 (5 minutes each)

6 – PUBLIC HEARING

None.

7 – ACTION MATTERS

Q Fluvanna Shovel Ready Sites Program (FSRSP)—Jason Smith, Community and Economic Development Director

R Farm Heritage Museum Update and Construction Contract - Cyndi Toler, Purchasing Officer, Eric Dahl, DCA/Finance Director, and Marvin Moss, Fluvanna County Historical Society

S FY17 To FY18 County Carryover Requests – Mary Anna Twisdale, Management Analyst

T FY17 To FY18 Schools Carryover Requests – Mary Anna Twisdale, Management Analyst

U Request to Rescind Resolution 17-2009 GIS Mapping Fees—Fred Payne, Count Attorney

V Charlottesville Area Alliance Support Resolution – Steve Nichols, County Administrator

W Fluvanna County Reassessment Process Proposal - Cyndi Toler, Purchasing Officer

8 – PRESENTATIONS (normally not to exceed 10 minutes each)

X ARC Building Upgrades—Wayne Stephens, Director of Public Works & County Engineer

9 – CONSENT AGENDA

YZ AP Report – October 2017 – Eric Dahl, DCA/Finance Director

10 – UNFINISHED BUSINESS

TBD

11 – NEW BUSINESS

TBD

12 – PUBLIC COMMENTS #2 (5 minutes each)

13 – CLOSED MEETING

Fluvanna County...The heart of Virginia and your gateway to the future!

TBD

14 – ADJOURN



Digitally signed by Steven M.
Nichols
Date: 2017.11.09 12:03:23 -05'00'

County Administrator Review

Fluvanna County...The heart of Virginia and your gateway to the future!

***For the Hearing-Impaired – Listening device available in the Board of Supervisors Room upon request. TTY access number is 711 to make arrangements.
For Persons with Disabilities – If you have special needs, please contact the County Administrator's Office at 591-1910.***

PLEDGE OF ALLEGIANCE

I pledge allegiance to the flag
of the United States of America
and to the Republic for which it stands,
one nation, under God, indivisible,
with liberty and justice for all.

ORDER

1. It shall be the duty of the Chairman to maintain order and decorum at meetings. The Chairman shall speak to points of order in preference to all other members.
2. In maintaining decorum and propriety of conduct, the Chairman shall not be challenged and no debate shall be allowed until after the Chairman declares that order has been restored. In the event the Board wishes to debate the matter of the disorder or the bringing of order; the regular business may be suspended by vote of the Board to discuss the matter.
3. No member or citizen shall be allowed to use abusive language, excessive noise, or in any way incite persons to use such tactics. The Chairman and/or the County Administrator shall be the judge of such breaches, however, the Board may vote to overrule both.
4. When a person engages in such breaches, the Chairman shall order the person's removal from the building, or may order the person to stand silent, or may, if necessary, order the person removed from the County property.

PUBLIC HEARING RULES OF PROCEDURE

1. PURPOSE
 - The purpose of a public hearing is to receive testimony from the public on certain resolutions, ordinances or amendments prior to taking action.
 - A hearing is not a dialogue or debate. Its express purpose is to receive additional facts, comments and opinion on subject items.
2. SPEAKERS
 - Speakers should approach the lectern so they may be visible and audible to the Board.
 - Each speaker should clearly state his/her name and address.
 - All comments should be directed to the Board.
 - All questions should be directed to the Chairman. Members of the Board are not expected to respond to questions, and response to questions shall be made at the Chairman's discretion.
 - Speakers are encouraged to contact staff regarding unresolved concerns or to receive additional information.
 - Speakers with questions are encouraged to call County staff prior to the public hearing.
 - Speakers should be brief and avoid repetition of previously presented comments.
3. ACTION
 - At the conclusion of the public hearing on each item, the Chairman will close the public hearing.
 - The Board will proceed with its deliberation and will act on or formally postpone action on such item prior to proceeding to other agenda items.
 - Further public comment after the public hearing has been closed generally will not be permitted.

Fluvanna County...The heart of Virginia and your gateway to the future!



COUNTY OF FLUVANNA

"Responsive & Responsible Government"

BOS Packet 2017-11-15 P.5/223
P.O. Box 540
Palmyra, VA 22963
(434) 591-1910
Fax (434) 591-1911
www.fluvannacounty.org

2016-2017 STRATEGIC INITIATIVES AND ACTIONS

Strategic Initiative A -- SERVICE DELIVERY

- A1** - Create a local Broadband Task Force to: assess our current status county-wide, determine our gaps and needs, develop alternatives and options for improvement, and to identify potential funding sources for broadband expansion.
- A2** - Perform Process Improvement Review of Planning and Zoning Processes.
- A3** - Perform Process Improvement Review of Building Inspection Processes.
- A4** - Implement credit card payment option for citizen at all County funds collection points through MUNIS Cashiering process.
- A5** - Update, format, and improve web-accessibility of all County Personnel Policies.
- A6** - Create Fluvanna County Data Website Dashboard with key metrics.
- A7** - Perform a comprehensive review and update of all ordinances, rules, policies, and practices relating to junk cars, trash and litter, waste tires, condemnation of structures, etc.
- A8** - Create an improved system for managing and tracking of SUPs and Subdivisions (Bond status, project status, etc.).

Strategic Initiative B -- COMMUNICATION

- B1** - Create a Community Impact Awards Program.
- B2** - Hold an Elected Official Breakfast for our State Representatives in Spring 2016
- B3** - Collect and analyze the results of the local Business Climate Survey.
- B4** - Hold a Local Business Forum - Subtitle: "The Future of Fluvanna's 250 Corridor"
- B5** - Create a local Business Support Action Plan.
- B6** - Assess options to communicate more efficiently, effectively, and economically with Fluvanna residents.
- B7** - Expand County Website to receive, answer, and post questions from residents.
- B8** - Improve communication and collaboration with the School Board to improve understanding of school system funding needs and better plan future budgets.
- B9** - Create a brief, easy to understand tax impact message showing Fluvanna advantages for both residential and business.

Strategic Initiative C -- PROJECT MANAGEMENT

- C1** - Investigate the use of Technology or other types of Overlay Zones for the Zion Crossroads Community Planning Area to support economic development aims.
- C2** - Create a County-wide overlay map showing utilities and other key features that support business growth and development.
- C3** - Investigate all options for GIS system delivery and management to support needs of all County departments.
- C4** - Develop and adopt a Fluvanna County Master Water and Sewer Service Plan and implementation schedule.
- C5** - Successfully oversee and manage Fluvanna County aspects of the James River Water project.

- C6** - Finalize locations and fund installation of Fire Hydrants in the Columbia District along the route of the Louisa County Water Authority raw water pipeline.
- C7** - Successfully oversee and manage the design and construction of the Zion Crossroads water and sewer system.
- C8** - Successfully oversee and manage the County's E911 Emergency Communications System Project.
- C9** - Proceed with the Pleasant Grove Farm Museum design.
- C10** - Investigate opportunities and options for a Palmyra Village Streetscape project to improve safety, parking, walkability, and overall appearance.

Strategic Initiative D -- ECONOMIC DEVELOPMENT AND TOURISM

- D1** - Create EDTAC - Economic Development and Tourism Advisory Council.
- D2** - Plan for Fluvanna County activities to celebrate the Virginia Business Appreciation Month in May 2016.
- D3** - Draft and adopt a formal County-wide economic development and tourism strategy inclusive of an implementation schedule.
- D4** - Create separate Tourism and Business information pages for the County website.
- D5** - Create a Fluvanna County "triangle" tourism brochure describing a Monticello, Pleasant Grove House & Museum, Old Stone Jail, Historic Courthouse, and Montpelier history and tourism route.
- D6** - Create a "Faces and Places of Fluvanna" Poster and Rack Card to market Fluvanna County as a destination for tourism and recreational activities.
- D7** - Create a "New Residents Guide" package for distribution to local Real Estate agents.
- D8** - Develop a "This is Fluvanna County" video message to be shared with county citizens and businesses as well as use with county economic development initiatives.
- D9** - Investigate and pursue with State offices the installation of select Boat Ramps along the Rivanna and James Rivers to support additional recreational and tourism opportunities.
- D10** - Investigate opportunities for park expansion or Rivanna River access points to support expanded recreational activities in Fluvanna (e.g., Crofton Park, LMOA river access areas, Town of Columbia flood plain/potential park, etc.).
- D11** - Support local businesses and entrepreneurs by establishing a focused business appreciation and expansion program.

Strategic Initiative E -- FINANCIAL STEWARDSHIP AND EFFICIENCY

- E1** - Identify all sources of revenue the county can use to finance local government programs and services and determine which sources Fluvanna County should utilize.
- E2** - Investigate creation of a "Capital Depreciation Fund" that would be funded within the tax rate each fiscal year to save for future capital needs.
- E3** - Update, format, and improve web-accessibility of all County Financial Policies.
- E4** - Review, update, and approve new Fluvanna County Proffer Guidelines.
- E5** - Reduce the County's reliance on creating and mailing paper checks for payments and to implement ACH/EFT transaction options.
- E6** - Research and provide samples of Monthly Treasurer Report options and formats so that the Board can decide what they would like to see on a recurrent basis (e.g., what reports are provided in other counties?). Create report for inclusion in Board package each month, as well as a quarterly in-person briefing on the data.

**FLUVANNA COUNTY BOARD OF SUPERVISORS
AGENDA ITEM STAFF REPORT**

TAB P

MEETING DATE:	November 15, 2017				
AGENDA TITLE:	Community Service Award Resolution Honoring Dr. Robert Mayfield				
MOTION(s):	I move the Board of Supervisors adopt the resolution entitled, "Community Service Award Resolution Honoring Dr. Robert D. Mayfield."				
STRATEGIC INITIATIVE?	Yes	No	If yes, list initiative(s):	B1	
	XX				
AGENDA CATEGORY:	Public Hearing	Action Matter	Presentation	Consent Agenda	Other
		XX			
STAFF CONTACT(S):	Jason Smith, Director of Community & Economic Development				
PRESENTER(S):	Steven M. Nichols, County Administrator				
RECOMMENDATION:	Approve				
TIMING:	Normal				
DISCUSSION:	See Resolution				
FISCAL IMPACT:	None.				
POLICY IMPACT:	None.				
LEGISLATIVE HISTORY:	None.				
ENCLOSURES:	Resolution				
REVIEWS COMPLETED:	Legal	Finance	Purchasing	HR	Other



BOARD OF SUPERVISORS
 County of Fluvanna
 Palmyra, Virginia

RESOLUTION No. 14-2017

**COMMUNITY SERVICE AWARD RESOLUTION
 HONORING DR. ROBERT D. MAYFIELD**

WHEREAS, Dr. Robert Mayfield came to Fluvanna County in 2002 as plant manager of the Tenaska Virginia Generating Station (TVGS), the first natural gas-fueled power plant in Virginia; and

WHEREAS, Dr. Mayfield’s leadership and service in Fluvanna County has been both admirable and worthy of esteem; and

WHEREAS, Dr. Mayfield and his TVGS team received the 2008 Virginia Governor Community Service and Volunteerism Award, achieved an impressive ten best practice awards from the Combined Cycle Journal, and lauded as one of the 2007 “model gas-fired plants in the world” in Power Magazine, and recognized its excellent operations record and good corporate citizenship in 2013 as one of the "top six natural gas-fueled plants worldwide," also by Power magazine; and

WHEREAS, Dr. Mayfield and his TVGS team are recognized as among the best in the energy industry as an OSHA Voluntary Protection Programs Star site, for which only 2,440 out of more than 7 million worksites nationwide, and just 41 in Virginia, hold this honor; and

WHEREAS, he has spearheaded Tenaska’s partnership with the Fluvanna County Department of Social Services "Angel Gift Program" by donating over \$60,000 for clothing, toys and gifts for children and the elderly. TVGS further partnered with the Fluvanna Food Bank to donate 320 turkeys for their annual Thanksgiving Food Drive, sponsored the County Sheriff’s annual award night & dinner, and hosted an the annual First Responders Appreciation Day and Dinner; and

WHEREAS, Dr. Mayfield partnered with Carysbrook Elementary to assist in implementing, participating in, and funding the ongoing success of their STEM program; and

WHEREAS, he is transferring to take on another challenging role at a Tenaska facility in Pennsylvania;

NOW, THEREFORE BE IT RESOLVED, on this 15th day of November, 2017, that the Fluvanna County Board of Supervisors hereby recognizes the significant Civic Responsibility, Community Leadership, Volunteer Services, and Mentoring & Coaching contributions of Dr. Robert D. Mayfield.

THE FOREGOING RESOLUTION WAS DULY AND REGULARLY ADOPTED by the Fluvanna County Board of Supervisors at the regular meeting of the Board held on the 15th day of November, 2017;

	AYE	NAY	ABSTAIN	ABSENT	MOTION	SECOND
Mozell H. Booker, Fork Union District	X					X
Patricia B. Eager, Palmyra District	X					
Anthony P. O’Brien, Rivanna District	X					
John M. Sheridan, Columbia District	X					
Donald W. Weaver, Cunningham District	X				X	

 John M. Sheridan, Chair
 Fluvanna County Board of Supervisors

**FLUVANNA COUNTY BOARD OF SUPERVISORS
 AGENDA ITEM STAFF REPORT**

TAB Q

MEETING DATE:	November 15, 2017				
AGENDA TITLE:	Fluvanna Shovel Ready Sites Program (FSRSP)				
MOTION(s):	<p>I move the Board of Supervisors to adopt the Fluvanna Shovel Ready Sites Program (FSRSP) Policy to support economic development in the Zion Crossroads Community planning Area, and whereby the Fluvanna County Economic Development Authority (EDA) will manage and maintain the FSRSP as a [grant / interest-free loan] program to support economic development in the Zion Crossroads Community Planning Area.</p> <p>I move the Board of Supervisors approve the realignment of \$35,000 in funding <u>FROM THE</u> Fluvanna County Economic Development Authority's Business Microloan Program, originally approved in 2012, and thus terminating the microloan initiative, and <u>TO THE</u> Fluvanna County Economic Development Authority's Fluvanna Shovel Ready Sites Program fund.</p>				
STRATEGIC INITIATIVE?	Yes	No	If yes, list initiative(s):		
		X			
AGENDA CATEGORY:	Public Hearing	Action Matter	Presentation	Consent Agenda	Other
		XX			
STAFF CONTACT(S):	Jason Smith - Community & Economic Development Director				
PRESENTER(S):	Jason Smith - Community & Economic Development Director				
RECOMMENDATION:	Approve				
TIMING:	Current				
DISCUSSION:	Staff presented FSRSP in October and would like to move forward with the program in partnership with the EDA.				
FISCAL IMPACT:	<ul style="list-style-type: none"> • No new funding required. • Approval of realignment \$35,000.00 in County funding originally allocated in 2012 for an EDA Business Microloan Program, and into the EDA's new FSRSP Fund. 				
POLICY IMPACT:	N/A				
LEGISLATIVE HISTORY:	See above.				

ENCLOSURES:	<ul style="list-style-type: none">• FSRSP Overview• Policy• Tier Checklist• Presentation				
REVIEWS COMPLETED:	Legal	Finance	Purchasing	HR	Other



Fluvanna Shovel Ready Sites Program

The Fluvanna Shovel Ready Sites Program (FSRSP) is geared toward improving the marketability of Fluvanna's planned growth areas in the site selection process. The program plays a vital role in Fluvanna County Economic Development by working with land owners, businesses and other community business partners to identify sites that can be rapidly developed. To be Shovel Ready, a site must have undergone an environmental process and qualified for expedited permitting with state regulatory agencies to allow quick investment and expansion.

Goals

- Help Fluvanna County prepare sites for development by pre-permitting a site as much as possible
- Help companies more easily navigate the selection and permitting process
- Generate a list of remaining permits necessary for a specific site
- Assist in fast-tracking any remaining state, federal and local business/industry specific permits
- Provide marketing assistance through the County's site selection database

Benefits

- Development ready
- Substantial due diligence completed
- Significant site information gathered and documented
- Independent third-party engineering review
- Uncertainty and potential obstacles eliminated through enhanced site knowledge
- More competitive
- Greater marketability
- Granted priority in site proposals
- Target Sites: Community Planning Areas

Minimum Standards for Assistance

- Ownership of property clearly identified.
- Between 2 and 99 contiguous acre's located within Zion Crossroads Community Planning Area (CPA).

Priorities

- **Viability:** the development required to prepare and position the site at a higher Tier Level can be implemented practically and successfully within a reasonable period of time.
- **Alignment:** the site has a connection to the local or regional economic development strategy.
- **Economic Impact:** the development of the site has a public purpose and would have a significant economic impact on the community and facilitate further increased prospect traffic and economic growth.
- **Commitment:** the scope of work required to increase a site's currently designated Tier Level to the next Tier Level (Scope of Work) is complete and the necessary financing for the implementation of the Scope of Work is available and documented or will be within a reasonable period of time, the required dollar for dollar match of the Site Development Grant requested is identified, and an estimated timeframe for implementation of the Scope of Work has been established.
- **Leveraged Resources:** the use of existing infrastructure, workforce and other community assets, e.g. grant funding or other resources used to support the site.

How It Works

The Fluvanna Economic Development Authority will lead the program administration of the Shovel Ready Sites Program and will utilize the County's Economic Development office to deliver a fast track permitting process.



Frequently Asked Questions

Fluvanna Shovel Ready Sites Program (FSRSP)

What is it?

Fluvanna County's Shovel Ready Sites Program is designed to identify both publicly and privately owned sites located in the County's Zion Crossroads Community Planning Area (CPA) which are suitable for development. The goal is to gather uniform site information to increase the quality of site documentation, as well as the overall number of sites that are ready for development.

Why should I participate?

The Shovel Ready designation will identify your property to developers, site selectors and companies looking for suitable start-up or expansion locations. Knowing this information up front helps brokers, site selectors, developers and companies accelerate their search, allowing these particular sites to stand out against the competition.

What are the minimum standards to participate in the program?

Site control of property and between 2 and 99 contiguous acres. Any other testing completed will be used when evaluating applications. Please review [page 3](#) of the FSRSP Application to see what services funding can be used for.

Are there any maximum or minimum acreage requirements to participate in the program?

The minimum amount of acreage is 2 to 99 contiguous acres that reside within Fluvanna County's Zion Crossroads CPA.

What are the eligible expenses that can be reimbursed?

Eligible expenses can be found on [page 3](#) in the application and include things like surveys, maps, photographs, environmental studies, etc.

What is the deadline for applications?

FSRSP applications are accepted year-round by the Economic Development Authority. Applications are due by close of business on the 1st Monday of the month in order to be reviewed by the EDA at their monthly meeting. Applicants will be notified of any award within 60 days of receipt of a complete application and all relevant materials. Subject to funding availability, applicants are eligible for reimbursement of up to 50% of their qualifying expenses upon verification of costs incurred. Site Development [grant / interest-free loan](#) award payments will be delivered after confirmation of work performed. Proof of applicable costs involved while preparing the application will need to be provided by the applicant such as invoices, copy of reports, assessments, evaluations, etc.

Will these sites receive any special preference or acknowledgement on the County/state's site selection database?

YES! Shovel Ready sites will be recognized and completed due diligence steps will be noted. Fluvanna County will actively market these sites to regional, national and international site selectors.

How does this differ from the State of Virginia Business Ready site program?

This designation is not meant to replace or compete with the State of Virginia Business Ready Site Program, but rather provide a scaled-down alternative for smaller sites or those that cannot meet the State's program criteria.

How do I apply?

Visit www.yesfluvanna.org or [Click here](#) for application and submission instructions.

	FLUVANNA COUNTY, VIRGINIA	
	Policy Subject:	Fluvanna Shovel Ready Sites Program (FSRSP)
	Policy Number:	
	Effective Date:	November 15, 2017
	Last Revision Date:	N/A

1. Program. The Fluvanna County Economic Development Authority (EDA) understands the risks and required expenditures in the early stages of development. These risks have prevented land owners in the Zion Crossroads Community Planning Area (CPA) from developing their properties to “shovel ready” sites that would encourage and attract businesses. To stay ahead of market conditions and provide potential businesses with the best opportunity to quickly begin operating in Fluvanna County, the EDA has developed the Fluvanna Shovel Ready Sites Program (FSRSP).

2. Policy

a. The FSRSP is established to help offset costs that the EDA believes may be prohibiting development in the County. The program provides a framework for expenditure of EDA funds based on site-eligibility guidelines and other selection criteria, whereby the EDA will provide funding support for necessary improvements at sites that are ripe for development, to include: engineering, rezoning, brownfield remediation, geotechnical investigation, archaeological and wetlands evaluation, surveying, and other related costs.

b. The EDA FSRSP Fund is hereby established in the initial amount of \$35,000 to support the potential development of selected property sites within the Zion Crossroads CPA. Such funding will be realigned from the previously allocated Business Microloan Program funding approved by the Board of Supervisors in 2012.

c. Program expenditures shall be made at the discretion of the EDA depending on the facts and circumstances of each individual project/expenditure, and in according to the program guidelines and selection criteria.

3. Program Eligibility and Selection Criteria. The EDA process will follow these basic steps: (1) working with potential applicants to select sites to develop, (2) determining eligibility, and (3) establishing amount and timing of expenditure disbursements dependent upon the circumstances and needs of the individual project. The site review and selection process may be revised by the EDA depending upon individual projects/expenditures. Eligibility and selection steps include:

a. Ownership of property must be clearly identified.

b. Owner must have a minimum of 2, but not more than 99 developable acres, and the property must be within the Fluvanna County Zion Crossroads CPA.

c. Potential applicants must have one or more of the following due diligence items remaining to be completed to prepare their property for development:

- Rezoning
- Brownfield Remediation
- Archaeological and historic surveys (with mitigation performed if required)
- Conceptual site plan
- Environmental Site Assessments
- Protected, rare, threatened, and endangered species reports
- Soils survey
- Wetlands evaluation (and mitigation if required)

d. Property owner(s) and consultants meet with the EDA to discuss overall project and suitability for FSRSP.

e. Owner(s) or their authorized representative(s) must submit a formal funding request application to the EDA.

4. Program Expenditures

a. When approved by the EDA, applicants are eligible for reimbursement of up to 50% of their costs incurred for due diligence efforts directly related to property development readiness following completion of work. Such reimbursement shall comply with the provisions of Virginia Code Section 15.2-4905-13.

b. Applicants are required to submit official documentation such as invoices, copy of reports, assessments, evaluations, etc., as are necessary for formal EDA verification of the costs incurred.

c. Approved reimbursement awards are in the form of grants to the applicant and need not be repaid to the EDA FSRSP fund.

OR

c. Approved reimbursement awards are in the form of interest-free loans to the applicant. The funds must be repaid to the EDA FSRSP fund upon the sale or other disposition of the benefitted parcel or on such terms and conditions approved by the EDA depending on the individual circumstances of each project/expenditure.





Shovel Ready Tier Level Checklist

Tier 1

- Ownership
 - Public
 - Public/private
 - Private
 - Agreeable to marketing the site for economic development purposes *and*
 - Access to property for site assessment and marketing purposes
 - *BUT* no established sales price
- Comprehensive plan reflects site as appropriate for industrial or commercial development and use
- Site is NOT zoned for industrial or commercial development
- Minimal or no infrastructure
- Minimal or no due diligence

Tier 2

- Ownership
 - Public
 - Public/private
 - Private
 - Option agreement or other documentation of a commitment to a competitive sales price
 - Agreement to permit access to the site for site assessment, construction and marketing
 - Agreement to market the site for industrial or commercial economic development
- Rezoning hearing needs to be scheduled
- Minimal or no infrastructure
- Minimal or no due diligence

Tier 3

- Zoned for industrial or commercial development and use
- Minimal or no infrastructure
- Due diligence completed, including:
 - Wetlands survey with Army COE approval within the last five years
 - Geotechnical borings
 - Boundary and topographical survey
 - Cultural resources review
 - Endangered Species Review
 - Phase I ESA
- Estimated costs of development quantified

Tier 4

- All infrastructure is in place or will be deliverable within 12 months
- All permit issues have been identified and quantified

Tier 5

- All permits are in place
- Site is ready for a site disturbance permit from the locality where site is located

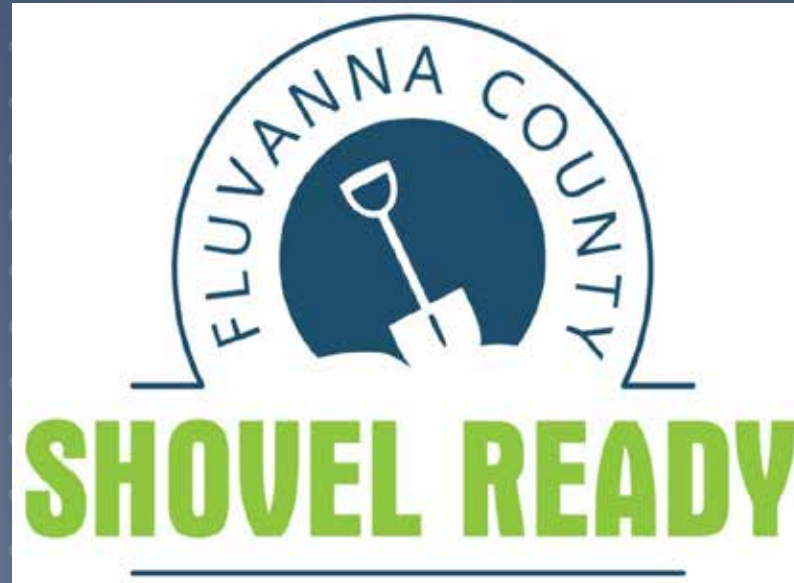

Fluvanna Shovel Ready Sites Program

Partnership between
the Fluvanna County Economic Development Authority
& the Community & Economic Development Department

VIRGINIA BUSINESS READY SITES PROGRAM

- „ Administered by VEDP
- „ Enacted/Funded by 2015 Virginia General Assembly
- „ 250-acre site characterizations
- „ 5 tier levels
- „ 2017 General Assembly lowered site requirement to 100 acres



HOWEVER...

QuickSearch
Search by property name, property ID, or street address

🔍

▼ PROPERTY TYPE

- Industrial Buildings
- Office Buildings
- Sites/Land
- Flex Buildings

▼ SIZE REQUIREMENT

Minimum Acres

n/a 5 10 25 50 100 500

▼ OTHER FEATURES

- Sewer (2)
- Water (1)

▶ TRANSPORTATION

▼ LOCATION

Regions

Add Region to Filter ▼ Show Map

MSAs

Add MSA to Filter ▼ Show Map

Localities

Add Locality to Filter ▼ Show Map

✕ Fluvanna

Hide Filter

List View
Map View
Property Sheet
Details List

9 properties found

Property Name	Site Size (acres)	Suitable for Construction	Largest Contiguous Parcel	Locality	Property ID	More Details	Photo	Add To Compare
Palmyra Associates	44	44	44	Fluvanna	265858	+	📷	🔍
Glass Property	31	31	31	Fluvanna	265733	+	📷	🔍
Houchens Property	29	29	29	Fluvanna	265868	+	📷	🔍
Deerfield Road	9	9	9	Fluvanna	245375	+	📷	🔍
Zion Crossroads Industrial Park - Lot 6	6	6	6	Fluvanna	244899	+	📷	🔍
Houchens/Lake Centre	5	5	5	Fluvanna	265869	+	📷	🔍
Figgins Property	4	4	4	Fluvanna	265841	+	📷	🔍
Starlite Park	3	3	3	Fluvanna	265494	+	📷	🔍
Hunters Branch Property at Zion Crossroads	3	3	3	Fluvanna	265966	+	📷	🔍

FLUVANNA SHOVEL READY SITE PROGRAM

- “ Fluvanna County Economic Development + Draper Aden Associates
- “ Improving the marketability of the County’s planned growth areas
- “ Helping companies and communities identify sites for rapid development
- “ To be shovel ready ----- environmental due diligence process and qualified for expedited permitting = *Quick investment and expansion*



BENEFITS

- „ Lowers cost of site development
- „ Improves efficiency of state permitting
- „ Enhances the marketability of the site
- „ Decreases potential risks of investing and improving new land



THE DETAILS

- " Minimum acreage – 2
- " Property must be within Fluvanna County's Zion Crossroads Community Planning Area
- " Funding covers surveys, mapping, environmental studies, geotechnical analysis, site planning/engineering
- " *Reimbursement* program!
- " \$:\$ match required
- " [Tier Checklist](#)



ROLES

- „ EDA & Economic Development Director to accept applications and recommend funding.
- „ EDA approves funding and issues Approved Site Characterization letter/certificate.
- „ BOS funds program annually as needed.





ROLL OUT

- December - Program Introduction at Community Luncheon(s)
- January 2018 - Launch!

COMMENTS AND QUESTIONS



**FLUVANNA COUNTY BOARD OF SUPERVISORS
AGENDA ITEM STAFF REPORT**

TAB R

MEETING DATE:	November 15, 2017				
AGENDA TITLE:	Farm Heritage Museum Construction				
MOTION(s):	<p>#1. I move the Board of Supervisors approve a FY18 supplemental appropriation of \$107,175.27 to the Farm Heritage Museum Capital Improvement Plan budget due to additional fund raising efforts of The Fluvanna Historical Society.</p> <p>#2. I move the Board of Supervisors approve a FY18 supplemental appropriation of \$56,895 from the Fluvanna County Unassigned Fund Balance to the Farm Heritage Museum Capital Improvement Plan Budget.</p> <p>#3. I move the Board of Supervisors approve the contract between Fluvanna County and Fuog/InterBuild, Inc. for services associated with the construction of the Farm Heritage Museum totaling \$307,114, and further authorize the County Administrator to execute the agreement subject to the County Attorney revisions for a proper agreement and approval as to form.</p>				
STRATEGIC INITIATIVE?	Yes X	No	If yes, list initiative(s):	C9	
AGENDA CATEGORY:	Public Hearing	Action Matter	Presentation	Consent Agenda	Other
		X			
STAFF CONTACT(S):	Cyndi Toler, Purchasing Officer				
PRESENTER(S):	Cyndi Toler, Purchasing Officer				
RECOMMENDATION:	recommend approval				
TIMING:	Routine				
DISCUSSION:	<ul style="list-style-type: none"> ✓ A new IFB with clear specifications and building plans issued in August 2017. ✓ In October 2017, the new IFB closed with a total of 3 bids. ✓ The Low bid from Fuog/InterBuild, Inc. for \$307,114.00 ✓ As of July 2016 the Historic Society had raised a total of \$160,824 (which is currently accounted for and budgeted) ✓ To date, they have raised \$268,000.00. (An increase of \$107,175.27 to what has already been budgeted) <ul style="list-style-type: none"> Ø \$70,000.00 coming from Grant Funds Ø The remaining contributed by Fluvanna County Citizens and Businesses. ✓ They have also indicated they plan continued fundraising in order to donate \$5,000 per year for the next 5 years to the Fluvanna County Parks and Rec Department. This will assist in offsetting the County's out of pocket expense. ✓ \$56,895 is needed in additional funding to move forward with construction. (This includes a 5% contingency for unknown expenses) 				
FISCAL IMPACT:	The Farm Heritage Museum budget will increase to \$339,895.				
POLICY IMPACT:	N/A				
LEGISLATIVE HISTORY:	N/A				
ENCLOSURES:	<ul style="list-style-type: none"> • Project Costs • "DRAFT" Contract 				

REVIEWS COMPLETED:	Legal	Finance	Purchasing	HR	Other
	X	X	X		

Farm Museum Project

6-Nov-17

Funding Category	Amount
------------------	--------

County Contribution	\$15,000
----------------------------	-----------------

Historical Society Contribution	\$268,000
--	------------------

Two Thistle Gate Vineyard events	\$10,000
----------------------------------	----------

Old Farm Day (50% of net) for 2 years	\$6,336
---------------------------------------	---------

Anonymous Fluvanna Resident	\$40,000
-----------------------------	----------

Perry Foundation Grant	\$30,000
------------------------	----------

Mary Morton Parsons Foundation Grant	\$30,000
--------------------------------------	----------

BAMA Works Foundation Grant	\$10,000
-----------------------------	----------

Anonymous Fluvanna Foundation	\$5,000
-------------------------------	---------

Miscellaneous citizen and business donations	\$136,664
--	-----------

TOTAL FUNDING COMMITMENT	\$283,000
---------------------------------	------------------

Project Design and Construction	Costs
---------------------------------	-------

Site Plan	\$15,000
-----------	----------

Custom Building Plans	\$2,425
-----------------------	---------

Construction Costs (per IFB low bid)	\$307,114
--------------------------------------	-----------

Construction Contingency (5%)	\$15,356
-------------------------------	----------

TOTAL COSTS	\$339,895
--------------------	------------------

ADDITIONAL FUNDING REQUIRED	(\$56,895)
------------------------------------	-------------------

Farm Museum Project

1-Nov-17

Funding Category	Amount
County Contribution	\$15,000
Historical Society Contributions	
Two Thistle Gate Vineyard events	\$10,000
Old Farm Day (50% of net) for 2 years	\$6,336
Anonymous Fluvanna Resident	\$40,000
Perry Foundation Grant	\$30,000
Mary Morton Parsons Foundation Grant	\$30,000
BAMA Works Foundation Grant	\$10,000
Anonymous Fluvanna Foundation	\$5,000
Miscellaneous citizen and business donations	\$136,664
Historical Society Total	\$268,000
TOTAL FUNDING COMMITMENT	\$283,000
Project Design and Construction	Costs
Site Plan	\$15,000
Custom Building Plans	\$2,425
Construction Costs (per IFB low bid)	\$307,114
TOTAL COSTS	\$324,539
FUNDING BALANCE	(\$41,539)

COUNTY OF FLUVANNA, VIRGINIA

CONTRACT FOR FARM HERITAGE MUSEUM BARN CONSTRUCTION

This Contract for Farm Heritage Museum Barn Construction (the “**Contract**”), is made this ___ day of _____, 2017 between the County of Fluvanna, a political subdivision of the Commonwealth of Virginia (“**County**”), and InterBuild, Inc., a Virginia corporation (“**Contractor**”).

WITNESSETH that the Contractor and the County, in consideration of the mutual covenants, promises and Contracts herein contained, agree as follows:

I. SCOPE OF SERVICES: The Contractor shall provide all labor, tools, equipment, service and materials to install, construct and build a Barn and the associated Site Work (the Barn and Site Work being the “Project” as such is more particularly described in the attached Exhibits 1 and 2) consistent with the Scope of Work identified in Exhibit 1, defined below, on the property known as the Pleasant Grove House and Museum which is located at 271 Pleasant Drive Drive, Palmyra, Virginia 22963 as such Project is more specifically described herein and in those exhibits hereto. Contractor must and all Work on the Project must meet or exceed all of the provisions and requirements of the Invitation for Bids dated August 30, 2017 Number 2018-01, as amended by Addendum # 1 and Addendum # 2 (as amended, the “**IFB**”), attached hereto and incorporated herein by reference as **Exhibit 1**, and the Contractor’s Bid dated October 20, 2017 (the “**Bid**”), the Bid is attached hereto and incorporated by reference herein as **Exhibit 2**. The labor, services, materials and other requirements of the IFB and Bid are hereinafter collectively referred to as the “**Work on the Project**”. The Work on the Project must be furnished by Contractor in a good and workmanlike manner and so as to pass without exception in the trade with new highest quality materials. Consistent with the IFB, the Work on the Project includes a 5-year warranty from the Completion Date as defined in Article IV on all labor and materials performed to complete the project; and in addition the Contractor agrees to assign any manufacturer’s warranties for any products, materials or equipment used to build the stage to the County.

Consistent with the IFB, prior to execution of the Contract by the County, the Contractor shall provide to the County performance and payment bonds in the form attached hereto as **Exhibit 3** insuring the full amount of the Contract Price, as defined in Article II.

II. COMPENSATION: The Contractor shall be paid a flat fee of THREE HUNDRED SEVEN THOUSAND ONE-HUNDRED FOURTEEN AND NO/100 DOLLARS (\$307,114.00) (the “**Contract Price**”) for the Work on the Project in accordance with this Contract and the Bid. All such payments shall be made in accordance with the terms of this Contract, the Bid, and

Section 47 “Payment” of the General Terms, defined below, and in no event shall Contractor be paid prior to the Completion Date, as defined below in Section IV.

III. OTHER CONTRACT TERMS: The County of Fluvanna General Terms, Conditions and Instructions to Bidders and Contractors included in the IFB as Appendix I are specifically incorporated herein by reference. Where any of the General Terms, Conditions and Instructions to Bidders and Contractors directly conflicts with any of the specific terms of this Contract, this Contract shall control. Where any of the General Terms, Conditions and Instructions to Bidders and Contractors directly conflicts with any of the specific terms of the Bid, the General Terms, Conditions and Instructions to Bidders and Contractors shall control.

IV. PERIOD OF PERFORMANCE: All Work on the Project is to be installed, operational and in compliance with this Contract, the IFB and the Bid to the satisfaction of the County in its sole discretion within _____ (____) days after execution of this Contract. The date that all Work on the Project are installed, operational and in compliance with this Contract, the IFB and the Bid to the satisfaction of the County in its sole discretion is the “**Completion Date**”.

V. MISCELLANEOUS. The headings of the sections of this Contract are inserted for convenience only and do not alter or amend the provisions hereof. A word importing the masculine or neuter gender only may extend and be applied to females and to corporations as well as males, and vice versa. A word importing the singular number only may extend and be applied to several persons or things as well as to one person or thing; and a word importing the plural number only may extend and be applied to one person or thing, as well as to several persons or things. This Contract may be executed in duplicate originals, any of which shall be equally authentic. This Contract may be executed in counterparts, together which shall constitute a fully executed Contract. In addition to allowing electronic signatures upon an electronic copy of this Contract, as provided by Virginia law, facsimile signatures upon any signature page will be considered to be original signatures.

Any notices required hereunder must be in writing and will be deemed to have been given if delivered by hand to the party notified or mailed by first class mail postage prepaid to the addresses shown below:

To the County:
 Fluvanna County Finance Department
 Attn: Ms. Cyndi Toler
 132 Main Street
 Palmyra, VA 22963

With a Copy to:
 Fluvanna County Attorney
 414 East Jefferson Street
 Charlottesville, VA 22902

To the Contractor:

InterBuild, Inc.
Attn: John Shourds, Project Manager
510 East Main Street
Purcellville, VA 20132

Any party may substitute another address for the one set forth above by giving a notice in the manner required. Any notice given by mail will be deemed to be received on the fifth day after deposit in the United States mail. Any notice given by hand will be deemed to be received when delivered. Notice by courier will be deemed to have been received on the date shown on any certificate of delivery.

Witness the following duly authorized signatures and seals:

Contractor: InterBuild, Inc.,
A Virginia corporation

County: Fluvanna County,
a political subdivision of the
Commonwealth of Virginia

BY: _____

BY: _____

Print Name: _____

Print Name: _____

Title: _____

Title: _____

Date: _____

Date: _____

Approved as to Form:

Fluvanna County Attorney

Exhibit 1

DRAFT



COUNTY OF FLUVANNA, VIRGINIA
Invitation for Bid (IFB) #2018-01
FARM HERITAGE MUSEUM BARN
Issue Date: August 30, 2017
Due Date: October 23, 2017 at 2 p.m. EST

Procurement & Technical Contact:

County of Fluvanna
 Cyndi Toler, Purchasing Officer
 132 Main Street
 P.O. Box 540
 Palmyra, VA 22963
 Ph: (434) 591-1930 ext. 1124
 Email: ctoler@fluvannacounty.org

All sealed bids shall be turned in no later 2:00 p.m. EST, Monday, October 23, 2017. All bids that are delivered via mail or are hand delivered must be addressed to the "Procurement Contact" listed above. Any Bids that are turned in late will be rejected and returned unopened. Any Bids sent in via facsimile, telephone, or email shall not be considered.

Bid documents may be picked up at the Fluvanna County Department of Finance located at 132 Main Street, 2nd floor, Palmyra, VA 22963 or by clicking on the following link: <http://www.fluvannacounty.org/services/finance/procurement/solicitations>.

1. GENERAL INFORMATION

- A. By this Invitation for Bids ("IFB"), the Fluvanna County Board of Supervisors (hereinafter the "County") is seeking competitive sealed bids from qualified licensed contractors (herein referred to interchangeably as "Contractor" or "Bidder") to establish a firm fixed price contract with Contractor to furnish, deliver, supply and install all necessary labor, and materials associated with the construction of a barn building (the "Barn") and complete any and all necessary or appropriate associated work at the site ("Site Work") in accordance with the specifications, terms and conditions stated herein. Collectively, the work on the Barn and Site Work are referred to herein as the "Project"
- B. The Barn and Site Work will be completed at the property where the Pleasant Grove House and Museum is located at current street address 271 Pleasant Grove Drive, Palmyra, Virginia 22963 (the "Property"). The Barn shall be located on the Property in the location depicted and as shown in that site plan entitled "Farm Heritage Museum & Parking Lot Improvements" dated December 16, 2016, which is attached hereto as Exhibit 1 and incorporated herein as a material part of this IFB (referred to herein interchangeably as the "Site Plan" or "Exhibit 1"). The building labeled "Farm Heritage Museum" on the Site Plan is the Barn. Parking improvements to existing lot are not included as part of this Project, except that the row of parking, including two spots demarcated as handicap parking, across from the building labeled "Proposed Parking Expansion: in Exhibit 1 are included as part of the Project.

2. PRE-BID CONFERENCE

- A. A non-mandatory pre-bid conference will be held on Friday, the 8th day of September 2017 at 10 a.m. at Pleasant Grove House and Museum, 271 Pleasant Grove Drive, Palmyra, Virginia 22963.
- B. At the pre-bid conference Bidders will be allowed to inspect and analyze the current environment and collect further data in determination of their ability to perform the work on the Project required. Any Procurement and technical questions shall be directed to Cyndi Toler, Purchasing Officer at ctoler@fluvannacounty.org during the course of this solicitation. The Bidder shall be presumed to have made a reasonable inspection of the premises before the time of Bid submission and shall be held responsible for all information available through such inspections; and submission of a Bid will be a confirmation that the Bidder did make a site inspection and is aware of all conditions affecting performance and price(s) submitted. The County may determine in its sole discretion that a second pre-bid conference is necessary, the date and time of any such second pre-bid conference will be disclosed in an amendment to this IFB.
- C. Any inquiries or requests for clarification or additional information must be delivered in writing (via email) to the County no later than September 22, 2017 by 2:00pm to the following email address: ctoler@fluvannacounty.org. All inquiries will be answered via an addendum, posted to eVA and the County website.

3. SCOPE OF WORK: Contractor shall provide, furnish deliver, supply and install, all necessary or appropriate labor, services, parts, tools, materials, equipment, items and resources as may be required to complete the work on the Project (the "Scope of Work"), in accordance with the specifications and terms and conditions stated herein, which Scope of Work, shall include at minimum, but is not limited to, all of the following:

- A. **Contractor Minimum Requirements:** At minimum the Contractor must meet these minimum performance standards:
 - i. The Contractor should have, at a minimum, a current Class "A" Contractor's license as issued by the Commonwealth of Virginia Board of Contractors, Department of Professional and Occupational Regulation.
 - ii. The Contractor shall possess the appropriate contractor's license with the specific specialty services as recognized by the Virginia Board for Contractors, Department of Professional and Occupational Regulation to perform electrical, roofing and any other services required for the work on the Project.
 - iii. The Contractor's firm should have been in business providing similar services promulgated in this solicitation for a minimum of five (5) consecutive years.
 - iv. The Contractor's personnel assigned to the resulting contract should wear appropriate uniforms or attire that, at a minimum, bear the contractor's company name, and shall be maintained in a professional condition at all times.
 - v. The Contractor shall be responsible for providing quality contractor, roofing, electrical and other services required for the performance of any work on the Project in accordance with industry standards, plans, directions and instruction as provided hereunder and in any resulting Contract.
 - vi. All equipment, materials and installation work provided as a part of the Project shall conform to the Virginia Uniform Statewide Building Codes, National Electrical Code, OSHA and the specifications of this IFB.
 - vii. Contractor(s) shall report any safety concerns, near misses, accidents and injuries related to the work area to the County immediately.

- viii. Contractor(s) shall warrant, replace or repair any defective product, materials, installation or services on the Project for five (5) years from County's acceptance of any work or services hereunder on the Project at no additional cost. County shall be deemed to have accepted services hereunder only after receipt of a proper and detailed invoice from Contractor for all of the work on the Project and payment by the County to Contractor in full on such invoice.
- ix. Contractor(s) shall respond to emergency warranty repairs within one (1) day and shall respond to routine warranty repairs within three (3) business days.
- x. The Contractor shall transfer and assign to the County any and all warranties or similar guarantees for any materials or products provided by Contractor to the County hereunder.
- xi. Personnel for Electric Services:
 - 1. Contractor(s) shall perform all electrical work on the Project under the supervision of a qualified master electrician. A qualified master electrician shall be a licensed electrician graduated from an accredited school or program and shall have five (5) years plus experience of practical experience in planning, laying out, supervising the installation and repair of wiring, apparatus, or equipment for electrical components regulated by the Building Code and any other applicable electrical regulations. Contractors shall provide a copy of their Class A Electrical Contractor certification and a copy of their Master Electrician license. Contractor(s) shall assure that all employees who will be performing work receive any required training necessary to perform the work. All helpers, assistants, and apprentices shall operate under the supervision of a journeyman or master electrician. The County reserves the right to review any Contractor(s) training documentation.
 - 2. Journeyman Electricians provided by the Contractor should have a minimum of three (3) years of experience performing electrical services in accordance with manufacturer's best practices and must be supervised by a Master Electrician.
- xii. Consistent with Virginia Code Section 2.2-4337, prior to execution of any contract the County will require the winning bidder to deliver a performance and payment bond in an amount equal to the contract price from an insurer licensed in Virginia.

- B. Building Specifications:** At minimum, the Barn and Site Work for the project must meet the following requirements:
- i. Be in all respects consistent with and meet any and all provisions, notes, requirements or specifications shown on that Site Plan attached hereto as Exhibit 1 and that "Great House Design" attached hereto as Exhibit 2 (referred to herein interchangeably as the "House Plans" or "Exhibit 2") and incorporated herein by reference as a material part of this IFB (collectively Exhibit 1 and Exhibit 2 are referred to herein as the "Plans"). Site work is required to the extent necessary to produce a finished Project that meets or exceeds all the requirements and specifications provided in this IFB, including without limitation the Plans.
 - ii. Be in all respects consistent with and meet any and all provisions, notes, requirements or specifications shown on the House Plans).
 - iii. Provide all materials, installation, services and labor necessary to pour, lay, install, weather, and seal the concrete foundation pad and concrete slab on which to install the Barn and to accommodate the overhang/porch described in the Plans and in this IFB.
 - iv. The Barn will not be connected to water, is exposed to the elements to the extent of the design, and shall not be heated or air conditioned. All concrete, electrical fixtures, wiring, buildings, materials and supplies of any kind used in the Project shall be durable and appropriate for the intended uses, weather, conditions, the Barn design and site. Contractor shall install electricity service at the Barn at the Standard 200-amp service.

Contractor shall provide appropriate Code Compliant grounding of the electrical service and building. Contractor shall include in its bid responsive to this IFB the cost to run and install electric service 5ft from Central Virginia Electrical Cooperative (CVEC) to be installed line at Pleasant Grove to the electrical box at the barn building. The exact location of electrical service to be provided by CVEC near the barn building is to be determined, if the distance is further than 5 ft., a contract modification will be executed for the additional work at a price agreed upon by the parties. The contractor agrees to coordinate with Central Virginia Electrical Cooperative to determine the route of the incoming electrical service lines and install service. The County prefers the electrical meter to be installed on the right, rear of the building (when facing from the driveway). Contractor shall install all the labor and materials associated with installation of electrical wiring, wiring for light fixtures, electrical outlets and other electrical appurtenances included in the Project and Plans. Lighting fixtures will be provided by the owner at a later time.

- v. Electrical outlets shall be spaced as required by Applicable Law (as defined in 1(G) below) and indicated in the Plans.
- vi. The Barn must have a Metal Roof with a minimum thirty (30) year warranty, Color to be determined by the owner at a later time. There is no requirement for Sheathing under the metal roof; we would prefer to have just the metal roofing with purlins.
- vii. Building and the Project shall be compliant with all Applicable law, as defined in 1(G) below.
- viii. All windows, doors or other access points to the Barn shall have period-appropriate locking mechanisms installed so that the Barn can be fully locked and sealed.
- ix. All windows shall be single pane and operational with UV treatments. The skylights will need to open for ventilation purposes.
- x. All doors shall be exterior doors.
- xi. Parking lot and sidewalks – Row of 10 crush and run/21A gravel spaces, including 2 Handicap Accessible Parking spaces, ADA accessible route and signage shall be constructed as shown on the Site Plan and shall compliant with Applicable Law (as defined in 1(G) below).
- xii. Siding will be Board and Batten using rough cut #2syp wood with a minimum 1-inch thickness and non-uniform widths, a random combination of 8", 10" and 12" widths. To be stained with PPG ProLuxe, Sikkens or approved equal. Color to be determined by the owner once a contractor has been chosen.
- xiii. All references in the Plans to using Douglas Fir wood should be replaced to use #2 Southern Yellow Pine.
- xiv. All references in the Plans to Insulation should be voided. There is no requirement for insulation.

C. ADDITIONAL REQUIREMENTS:

- i. The Contractor shall
 - 1. Assign a Supervisor to the project that shall be the main point of contact for the project.
 - 2. Assure and guaranty that all equipment, materials, and installation work shall conform to the 2012 Virginia Uniform Statewide Building Codes, OSHA, and this IFB.
 - 3. Examine the work areas and site conditions under which work stated herein shall be performed. Contractor shall notify County of any condition(s) which may affect installation of building structure.
 - 4. Locate and clearly mark all underground utilities prior to construction.
 - 5. Perform all site preparation work inclusive of soil excavation and rough grade.
 - 6. Provide grade stakes or locator flags to flag corners of building.

7. Obtain building permit.
8. Please include in proposal cost for concrete and compaction tests.
9. Provide on-site supervision of construction activities.
10. Provide final approval/inspection and acceptance of building structure.
11. Provide finished grading and/or landscape work.
12. Verify site preparation work with a County designated Project Manager.
13. Deliver building materials to site location as designated by the Project Manager.
14. A temporary security fence will be required around site for the duration of construction.
15. Erect building.
16. Furnish and install all supplementary or miscellaneous items, appurtenances and devices incidental to or necessary for a sound, secure and complete installation.
17. Provide County with any applicable manufacturer warranties. A copy of these shall be provided with your bid response.
18. Agree to all of the provisions of the County of Fluvanna's General Terms, Conditions and Instructions to Bidders and Contractors attached to this IFB as Appendix I and further shall agree that any resulting contract awarded pursuant to this IFB shall incorporate by reference as material provisions of such Contract the County of Fluvanna's General Terms, Conditions and Instructions to Bidders and Contractors. Any resulting Contract shall be in form acceptable to the County in its sole discretion.

D. PROTECTION OF PERSON AND PROPERTY:

- i. All materials shall be protected from damage during delivery, storage and installation.
- ii. Temporary power will be made available to chosen contractor.
- iii. Work can be done on property from sun up to sun down 7 days a week.
- iv. The Contractor shall not remove any excess (unused) construction material from the site without the owner's approval. The Owner shall be reimbursed for the unused construction material or keep the material onsite.
- v. The Contractor is responsible to keep a clean and safe construction area at the end of each work day.
- vi. Contractor shall be responsible for initiating, maintaining and supervision of all safety precautions in connection with the work being performed. Any damage to existing Property, site, buildings, land or personal property, resulting from the Work on the Project or the performance of a Contract awarded pursuant to this IFB shall be repaired or replaced at the sole cost and expense of the Contractor to the satisfaction of the County. The Contractor shall repair and/or replace any damage done to any County property by their employees or resulting from Contractor's services as soon as practicable, but in any event, no more than ten (10) calendar days after notification by the County. All such repairs or replacements shall be completed to the County's sole satisfaction. To protect the Contractor, the Contractor shall document any damages in the project area prior to commencing work. This written record shall be provided to the County prior to commencing work.

E. BUILDING PERMITS & INSPECTIONS:

- i. The Contractor shall notify Miss Utility to locate all underground utilities and their depth and location prior to starting any work on the Project.
- ii. The Contractor shall apply for all required building permits before starting the Work on this Project.

- iii. Contractor shall notify the county to arrange for inspections at agreed milestones and shall notify for final inspection.
- iv. Site Plan is attached as Exhibit 1 hereto.

F. INSURANCE REQUIREMENTS:

- i. The firm shall agree to carry the required liability insurances that are listed under item number 39 of the "GENERAL TERMS, CONDITIONS AND INSTRUCTIONS TO BIDDERS AND CONTRACTORS" attached hereto as Appendix I.
- ii. By signing and submitting a proposal under this solicitation, the Contractor certifies that if awarded the contract, it will have the insurance coverage required at the time the work commences. The Contractor further certifies that the contractor will maintain the specified coverage during the entire term of the contract and that all insurance coverage will be provided by insurance companies authorized to sell insurance in Virginia by the Virginia State Corporation Commission.
- iii. During the period of the contract the County reserves the right to require the Contractor to furnish certificates of insurance for the coverage from time to time.
- iv. This is a construction contract under the Virginia Public Procurement Act and Performance and Payment Bonds shall be required pursuant to Virginia Code Section 2.2-4337.

G. APPLICABLE LAW: The Contractor shall comply with applicable federal, State and local laws, ordinances, rules and regulations in performance of the Contract ("Applicable Law"), including without limitation:

- i. The Americans with Disabilities Act, as this Project is a new construction Project for a unit of government; and
- ii. The Virginia Statewide Building Code.

4. SUBMITTAL INSTRUCTIONS

- A. The County will not be responsible for any expenses incurred by a firm in preparing and submitting a Bid. All Bids shall provide a straight-forward, concise delineation of the firm's capabilities to satisfy the requirements of this IFB. Emphasis should be on completeness and clarity of content. The contents of the Bid submitted by the successful Bidder and this IFB, and any amendments thereto, will become part of any contract awarded as a result of this IFB.
- B. The format of each bid must contain the following elements organized into separate chapters and sections, as the Bidder may deem appropriate. The following paragraphs provide guidelines to each Bidder for information to include in the bid document:
- C. **Cover Letter** - Provide a cover letter that confirms the Bidder's understanding of this IFB and a general understanding of the Project.
- D. **Overview** - The purpose of this section is to provide Fluvanna County with an overview of the history, qualifications and abilities of the Contractor's firm and for the Contractor to demonstrate the specific qualifications of the staff the Contractor will assign to this Project if selected. At a minimum, the proposal should: (i) Designate a Project Manager and indicate office location; and (ii) Include the organization chart, functional discipline, and responsibilities of Project team members.
- E. **Resumes/Qualifications** - Provide a concise resume or description of each principal team member's education, relevant professional experience, length of time employed by the Contractor and/or sub-consultant, and professional licenses. Each firm submitting a proposal shall provide an

updated statement of qualifications highlighting the expertise and experience of the firm and its personnel related to the Project.

- F. **Demonstrated History of Successful Projects** - Discuss recent project information of similar type to the Project completed by the firm including the project name, location, brief description of the project, description of the scope of services provided, and principal contact person. List all work of a similar nature to the Project completed for any department or agency of the Commonwealth of Virginia and any Virginia public body or locality.
- G. **Proposed Sub-Consultants** - The Contractor shall clearly state whether it is proposing to subcontract any of the work herein. The names of all proposed sub-contractors shall be provided. By proposing such firm(s) or individuals, the Contractor assumes full liability for the sub-consultant's performance. The Contractor shall state the amount of previous work experience with the sub-consultant(s).
- H. **References:** Provide the current name, address, and telephone number of at least four (4) references the Contractor has served either currently or in the past three (3) years; preferably those where one or more of the Project team members provided the same or similar services as requested herein. Indicate the Scope of Services provided to each reference.
- I. **Pricing** – Please provide flat lump sum pricing. The lump sum price shall include all labor, materials, services, equipment, tools, consumables, parts, supervision, permitting, overhead, administrative, overhead, delivery, shipping, handling, travel and other costs, fees or charges of any kind related to or required for the Work on the Project.
- J. **Project Full Specifications** - Please provide full specifications and features of Barn, landscaping, lighting, materials, concrete, roofing, and all of materials and a detailed listing of all Site Work. Please provide a detailed floor plan. Please provide pictures, pamphlets and materials related to the materials (such as windows, locks, doors, skylights, fans, concrete, finishes, paints, etc.) that will be used.
- K. **Forms:** All forms required to be submitted under this IFB must be included in the Bid.
- i. Vendor Data Sheet (Attachment A)
 - ii. Proof of Authority to Transact Business in Virginia (Attachment B)
 - iii. Certificate of No Collusion (Attachment C)
 - iv. Bidder Statement (Attachment D)
- L. The County is not responsible for failure to locate, consider and evaluate qualification factors presented outside this format.
- M. Any information thought to be relevant, but not applicable to the enumerated scope of work, should be provided as an appendix to the bid. If publications are supplied by the Offeror to respond to a requirement, the response should include reference to the document number and page number. Bids not providing this reference may be considered to have no reference material included in the additional documents.
- N. Each firm submitting a bid shall provide an updated statement of qualifications. The following is the minimum to be considered a complete bid:
- i. Expertise and experience of the firm related to the scope of services contained in this IFB. This section shall include recent project information of similar type completed by the firm

- along with the name and telephone number of the point of contact for each project.
 - ii. Financial responsibility of the firm.
 - iii. The firm should include a street address of the office proposed to handle the work.
 - iv. Identification and statement of qualifications of the construction project team who will be assigned to the Project for actual “hands on” work, as well as the principal assigned the Project for oversight responsibilities.
 - v. Provide your proposed Project timeline/completion schedule.
- O. The County is not responsible for failure to locate, consider and evaluate qualification factors presented outside this format.

5. SUBMITTAL INSTRUCTIONS

- A. **Each Bidder must submit one (1) original and four (4) copies along with one (1) electronic copy of its bid documents on CD ROM, DVD, or USB flash drive/memory stick.**
 - B. An authorized representative of the Bidder shall sign bid documents. All information requested should be submitted. Failure to submit all information requested may result in the bid being rejected by the County.
 - C. All forms attached to this IFB must be fully completed, executed by the Bidder and returned as a part of Offer’s Bid.
 - D. **Each bid shall be in writing and received in hard copy by the deadline. Oral bids, bids received by telephone, fax, telegraph, or email shall be rejected.**
6. **CONTRACT AWARD:** The contract will be awarded to the lowest responsible and responsive bidder whose bid, conforming to this IFB, is most advantageous to the County, considering price and any other evaluation criteria set forth in the bid documents and consistent with the Virginia Procurement Act, the County’s Code, the County’s Procurement Policies and Procedures and other applicable law. Nothing herein requires that the County complete this Work and the County may determine not to award any Contract pursuant to this IFB in its sole discretion for any reason or no reason at all.

7. TERMS

- A. The County’s General Terms, Conditions, and Instructions to Bidders and Contractors are attached hereto and incorporated herein by reference as Appendix I. These provisions bind all Bidders. Further, the conditions and requirements of this IFB, including, but not limited to, County’s General Terms, Conditions, and Instructions to Bidders and Contractors, are a material part of any contract awarded between the County and the successful Bidder(s).
- B. Awards shall be made to as many Bidders as deemed necessary to fulfill the anticipated requirements of the County. The County may award contracts to multiple Bidders and use their services for some or all of the projects identified herein. The County may choose not to award a contract or Notice to Proceed for any or all projects described herein.

VENDOR DATA SHEET

Note: The following information is required as part of your response to this solicitation. Failure to complete and provide this sheet may result in finding your bid nonresponsive.

1. Qualification: The vendor must have the capability and capacity in all respects to satisfy fully all of the contractual requirements.

2. Vendor's Primary Contact:

Name: _____ Phone: _____

3. Years in Business: Indicate the length of time you have been in business providing this type of good or service: _____ Years _____ Months

4. Vendor Information:

FIN or FEI Number: _____ If Company, Corporation, or Partnership

SSN: _____ (If Vendor is a sole proprietor)

5. Indicate below a listing of at least four (4) current or recent accounts, either commercial or governmental, that your company is servicing, has serviced, or has provided similar goods. Include the length of service and the name, address, and telephone number of the point of contact.

Company:	Contact:
Phone:	Email:
Dates of Service:	\$\$ Value:

Company:	Contact:
Phone:	Email:
Dates of Service:	\$\$ Value:

Company:	Contact:
Phone:	Email:
Dates of Service:	\$\$ Value:

Company:	Contact:
Phone:	Email:
Dates of Service:	\$\$ Value:

By my signature below, I, as a duly authorized representative of the entity named below, certify the accuracy of the foregoing information:

_____ Date: _____
 Legal Name of Entity if Applicable

By: _____ (SEAL) Print Name: _____
 Signature of Authorized Representative

Print Title: _____

Vendor Certification (for a Sole Proprietor):

_____ (SEAL) Print Name: _____ Date: _____
 Signature

PLEASE RETURN THIS PAGE WITH PROPOSAL SUBMISSION – [REQUIRED]

PROOF OF AUTHORITY TO TRANSACT BUSINESS IN VIRGINIA

THIS FORM MUST BE SUBMITTED WITH YOUR PROPOSAL/BID. FAILURE TO INCLUDE THIS FORM MAY RESULT IN REJECTION OF YOUR PROPOSAL/BID

Pursuant to Virginia Code §2.2-4311.2, an Offeror/Bidder organized or authorized to transact business in The Commonwealth pursuant to Title 13.1 or Title 50 of the Code of Virginia shall include in its proposal/bid the identification number issued to it by the State Corporation Commission (“SCC”). Any Offeror/Bidder that is not required to be authorized to transact business in the Commonwealth as a foreign business entity under Title 13.1 or Title 50 of the Code of Virginia or as otherwise required by law shall include in its proposal/bid a statement describing why the Offeror/Bidder is not required to be so authorized. Any Offeror/Bidder described herein that fails to provide the required information shall not receive an award unless a waiver of this requirement and the administrative policies and procedures established to implement this section is granted by the County Administrator, as applicable. If this quote for goods or services is accepted by the County of Fluvanna, Virginia, the undersigned agrees that the requirements of the Code of Virginia Section 2.2-4311.2 have been met.

Please complete the following by checking the appropriate line that applies and providing the requested information. **PLEASE NOTE: The SCC number is NOT your federal ID number or business license number.**

A. _____ Offeror/Bidder is a Virginia business entity organized and authorized to transact business in Virginia by the SCC and such vendor’s Identification Number issued to it by the SCC is _____.

B. _____ Offeror/Bidder is an out-of-state (foreign) business entity that is authorized to transact business in Virginia by the SCC and such vendor’s Identification Number issued to it by the SCC is _____.

C. _____ Offeror/Bidder does not have an Identification Number issued to it by the SCC and such vendor is not required to be authorized to transact business in Virginia by the SCC for the following reason(s):

Please attach additional sheets if you need to explain why such Offeror/Bidder is not required to be authorized to transact business in Virginia.

Legal Name of Company (as listed on W-9): _____

Legal Name of Offeror/Bidder: _____

Date: _____

Authorized Signature: _____

Print or Type Name and Title: _____

PLEASE RETURN THIS PAGE WITH PROPOSAL SUBMISSION – [REQUIRED]

CERTIFICATE OF NO COLLUSION:

The undersigned, acting on behalf of _____, does hereby certify in connection with the procurement and proposal to which this Certificate of No Collusion is attached that:

This proposal is not the result of, or affected by, any act of collusion with another person engaged in the same line of business or commerce; nor is this proposal the result of, or affected by, any act of fraud punishable under Article 1.1 of Chapter 12 of Title 18.1 of the Code of Virginia, 1950, as amended (18.2-498.1 et seq.).

The undersigned declares that the person or persons signing this proposal is/are fully authorized to sign the proposal on behalf of the firm listed and to fully bind the firm listed to all conditions and provisions thereof.

Respectfully submitted this _____ day of _____, 2015.

Legal Name of Entity

By: _____ (SEAL)
Signature of Authorized Representative

Print Name: _____

Print Title: _____

Date: _____

ACKNOWLEDGEMENT

State of _____
In the County/City of _____, **to-wit:**

The foregoing Certification of No Collusion was subscribed and sworn to before me by _____ (Print Name), _____ (Print Title) on behalf of _____ (Print Name of Entity) on this _____ day of _____ (month), _____ (year).

Notary Public

My commission expires: _____

Registration Number: _____

PLEASE RETURN THIS PAGE WITH PROPOSAL SUBMISSION – [REQUIRED]

OFFEROR STATEMENT

The undersigned Offeror hereby certifies that the Offeror has carefully examined all instructions, plans, conditions, specifications and other documents or items of this Request for Proposal and hereby submits this Proposal pursuant to such instructions, plans, conditions, specifications and other documents or items.

Complete if Offeror is an Entity:

WITNESS the following duly authorized signature and seal:

Name of Entity: _____
By: _____ (SEAL)
Signature

Print Name: _____
Print Title: _____

STATE OF _____
COUNTY/CITY OF _____, to-wit:

The foregoing instrument was acknowledged before me this ____ day of _____ (month),
_____ (year) by _____ (Print Name),
_____ (Print Title) on behalf of _____ (Name of
Entity).

Notary Public [SEAL]

My commission expires: _____
Notary registration number: _____

Complete if Offeror is a Sole Proprietor:

Witness the following signature and seal:

Signature (SEAL)

Print Name: _____

STATE OF _____
COUNTY/CITY OF _____, to-wit:

The foregoing instrument was acknowledged before me this ____ day of _____ (month),
_____ (year) by _____ (Print Name), a sole proprietor.

Notary Public [SEAL]

My commission expires: _____
Notary registration number: _____

PLEASE RETURN THIS PAGE WITH PROPOSAL SUBMISSION – [REQUIRED]

EROSION & SEDIMENT CONTROL LEGEND

No.	TITLE	KEY	SYMBOL
3.02	TEMPORARY STONE CONSTRUCTION ENTRANCE	(CE)	
3.05	SILT FENCE	(SF)	
3.07	STORM DRAIN INLET PROTECTION	(IP)	
3.17	STORMWATER CONVEYANCE CHANNEL	(SCC)	
3.18	OUTLET PROTECTION	(OP)	
3.20	ROCK CHECK DAM	(CD)	
3.21	LEVEL SPREADER	(LS)	
3.30	TOPSOILING	(TO)	
3.31	TEMPORARY SEEDING (THROUGHOUT UNPAVED AREAS W/IN LIMITS OF DISTURBANCE)	(TS)	
3.32	PERMANENT SEEDING (THROUGHOUT UNPAVED AREAS W/IN LIMITS OF DISTURBANCE)	(PS)	
3.35	MULCHING (THROUGHOUT UNPAVED AREAS W/IN LIMITS OF DISTURBANCE)	(MU)	
3.36	SOIL STABILIZATION BLANKETS & MATTING	(B/M)	
3.39	DUST CONTROL (ENTIRE AREA W/IN LIMITS OF DISTURBANCE)	(DC)	

PAVEMENT & DEMOLITION LEGEND

	GRAVEL PARKING AND PATH (SEE SECTION, SHEET C5.1)
	REMOVE WOODEN WHEEL STOPS

GRADING LEGEND

SW:	GRAVEL PATH ELEVATION
INV:	SMALL INVERT ELEVATION
G:	GROUND ELEVATION
P:	GRAVEL ROAD/PARKING ELEVATION
ME:	MATCH EXISTING ELEVATION
E:	APPROXIMATE EXISTING ELEVATION, CONTACT ENGINEER FOR ACTUAL FIELD ELEVATION VARIES BY 41'.

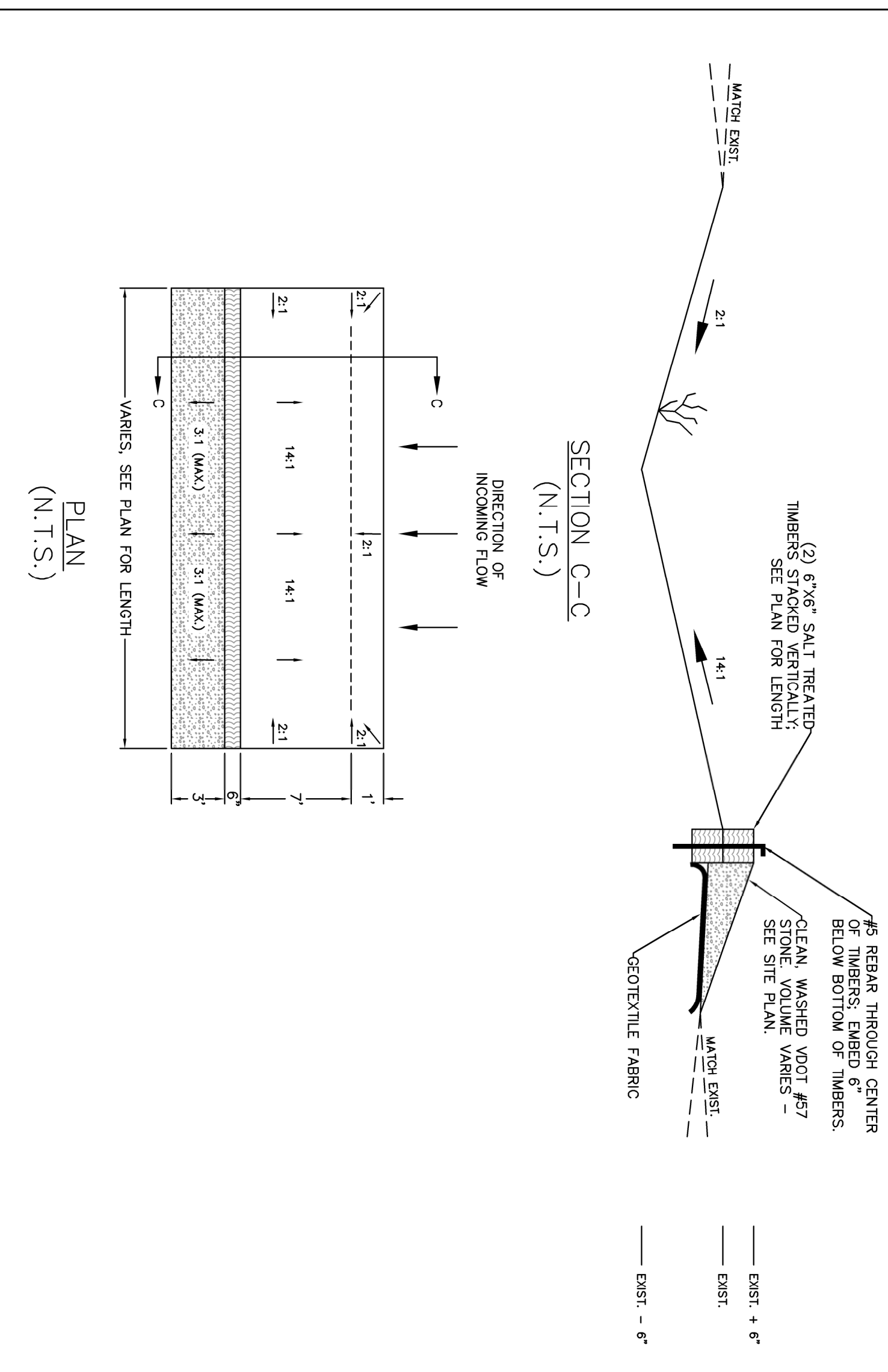

ENGINEERED LEVEL SPREADER (VESCH SECT. 3.21; VA DEQ STORMWATER DESIGN SPEC. NO. 2)

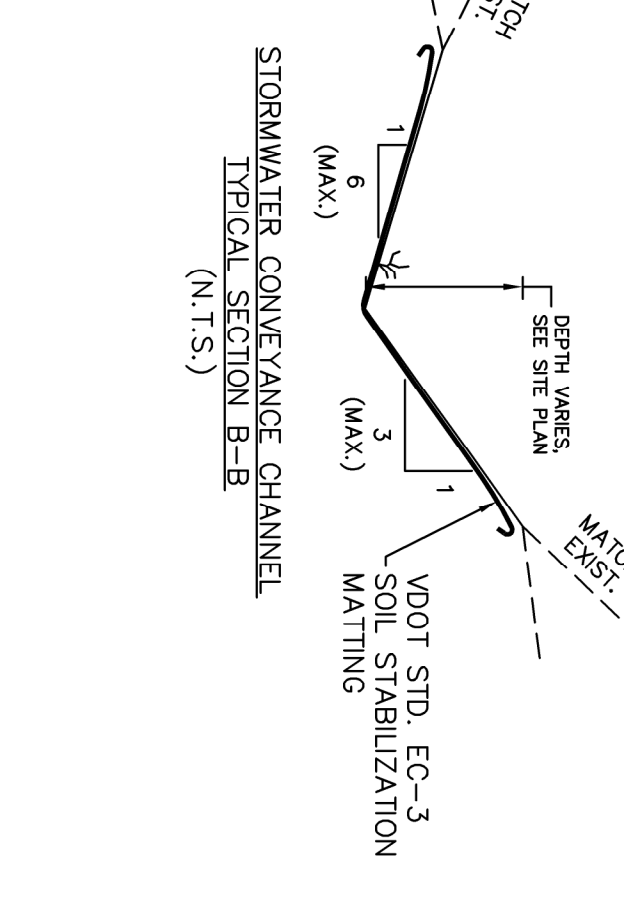
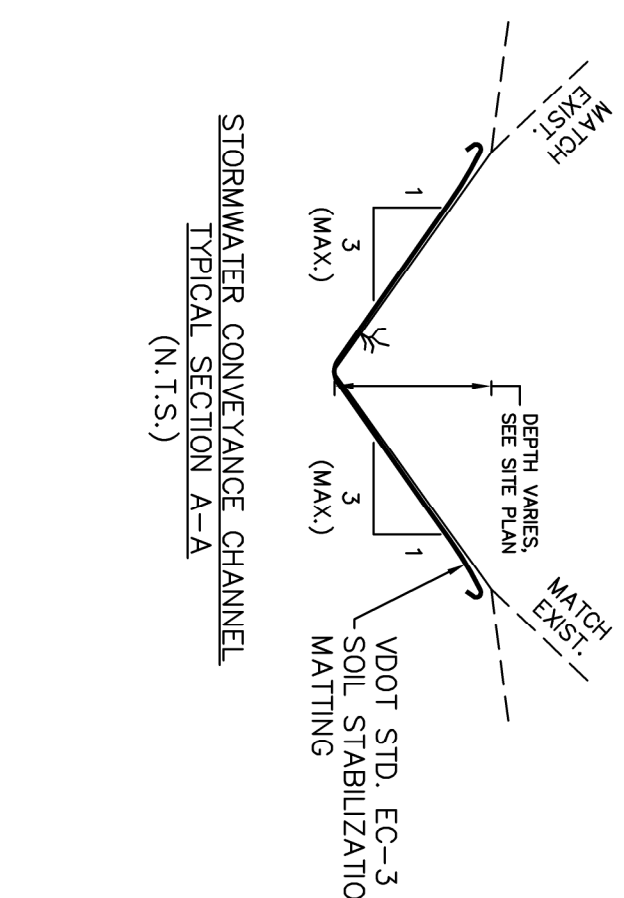
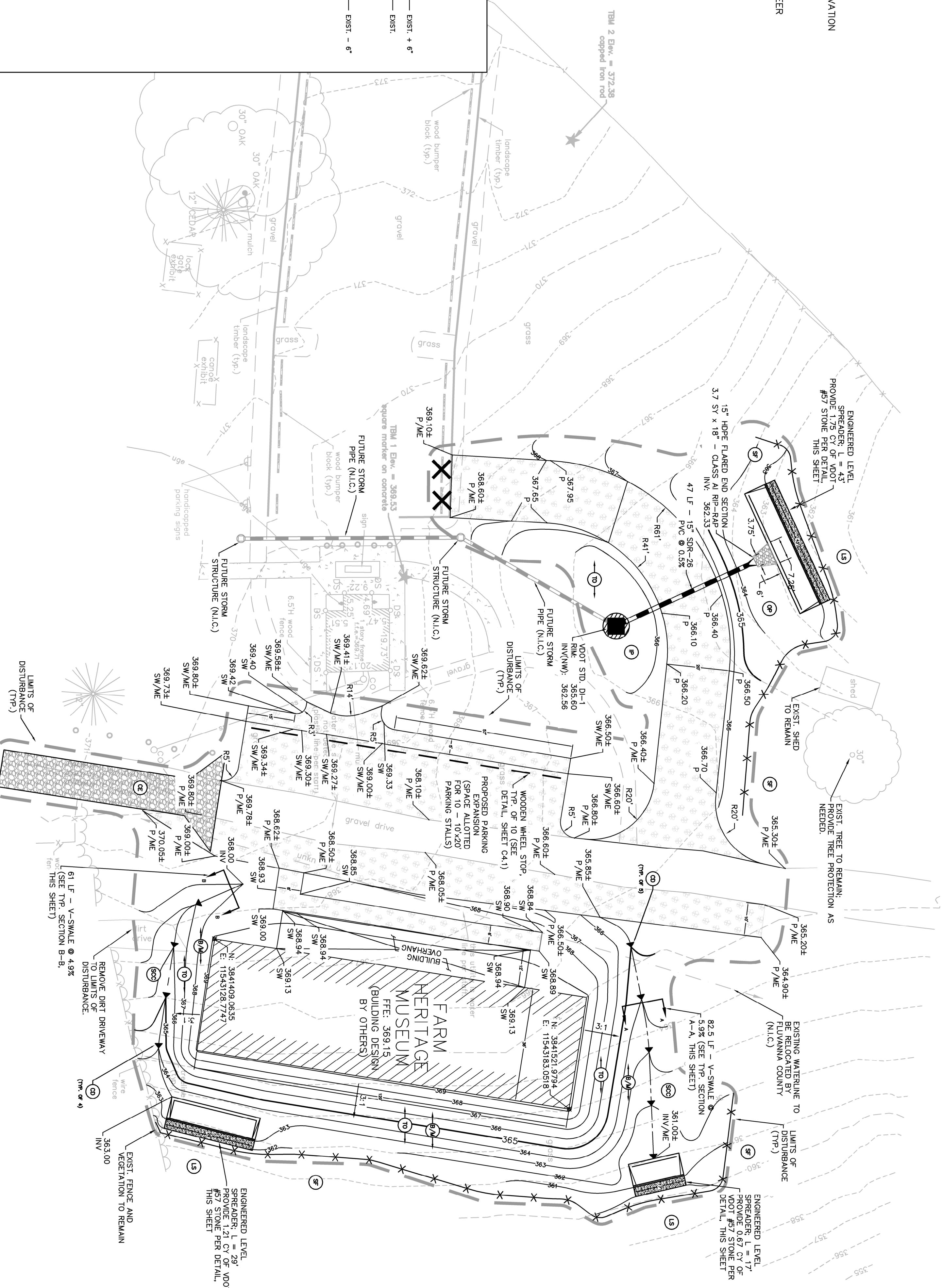
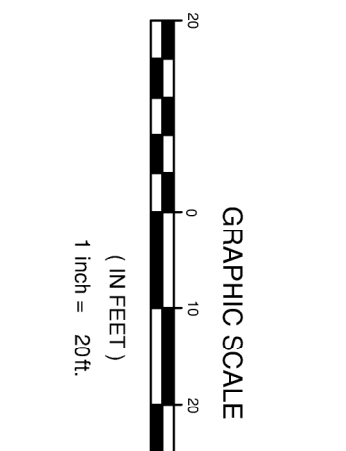

REVISIONS	

SITE PLAN
FARM HERITAGE MUSEUM & PARKING LOT IMPROVEMENTS
 PALMYRA, VIRGINIA

Draper Aden Associates
 Engineering • Surveying • Environmental Services

Charlottesville, VA 110 Avon Street Charlottesville, VA 22902 434-295-0700 Fax: 434-295-2105 www.daa.com

Richmond, VA • Blacksburg, VA • Hampton Roads, VA • Coats, NC • Fayetteville, NC • Northern Virginia

COMMONWEALTH OF VIRGINIA
 PROFESSIONAL LAND SURVEYOR
 License No. 42776
 Exp. 12/16/2019

DESIGNED BY:	CAH
DRAWN BY:	CEP
CHECKED BY:	CAH
SCALE:	1" = 20'
DATE:	DECEMBER 16, 2016
PROJECT NUMBER:	R13457C-11
C3.0	

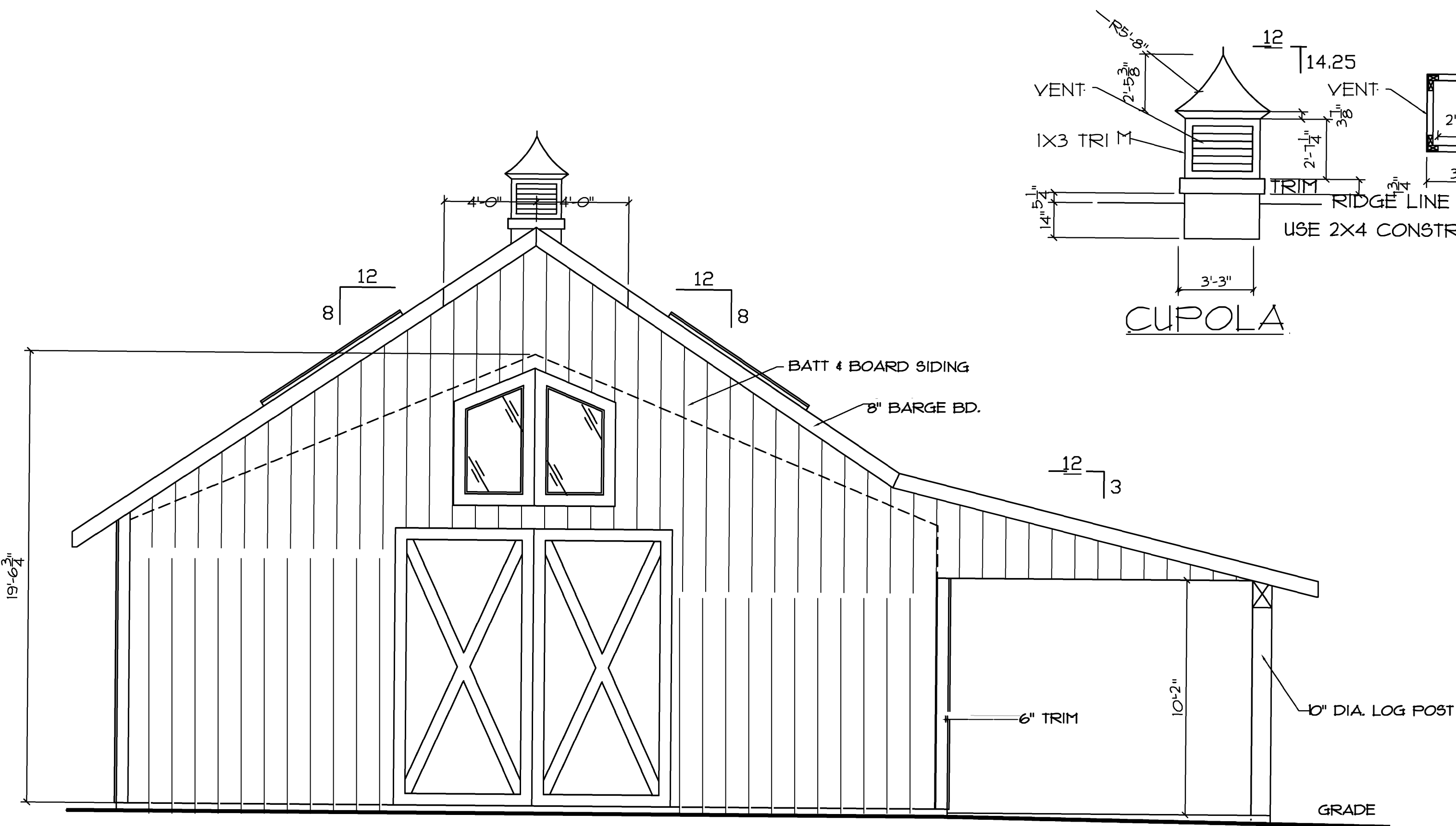

FRONT ELEVATION
SCALE: 1/4"=1'-0"

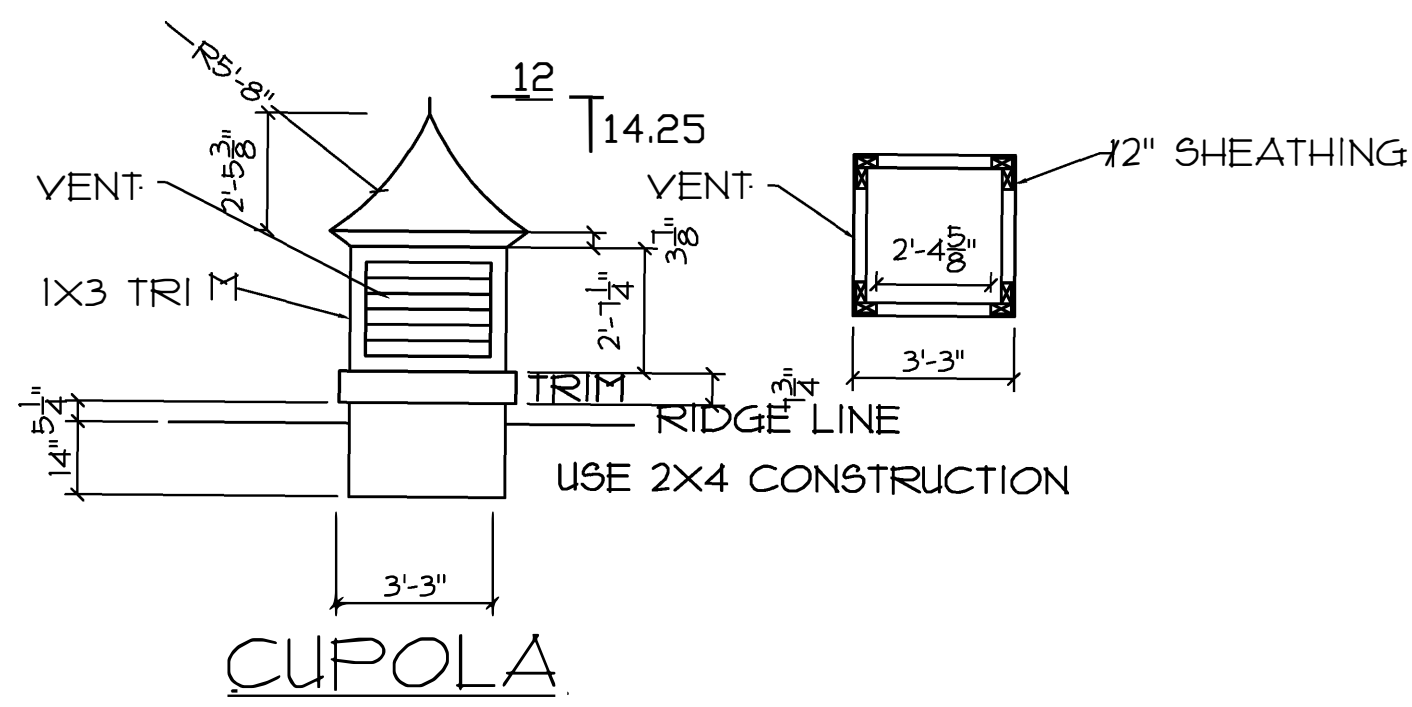

CUPOLA

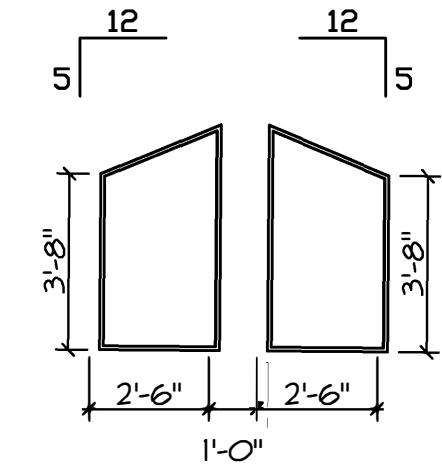

CUSTOM WINDOWS
SCALE: 1/4"=1'-0"

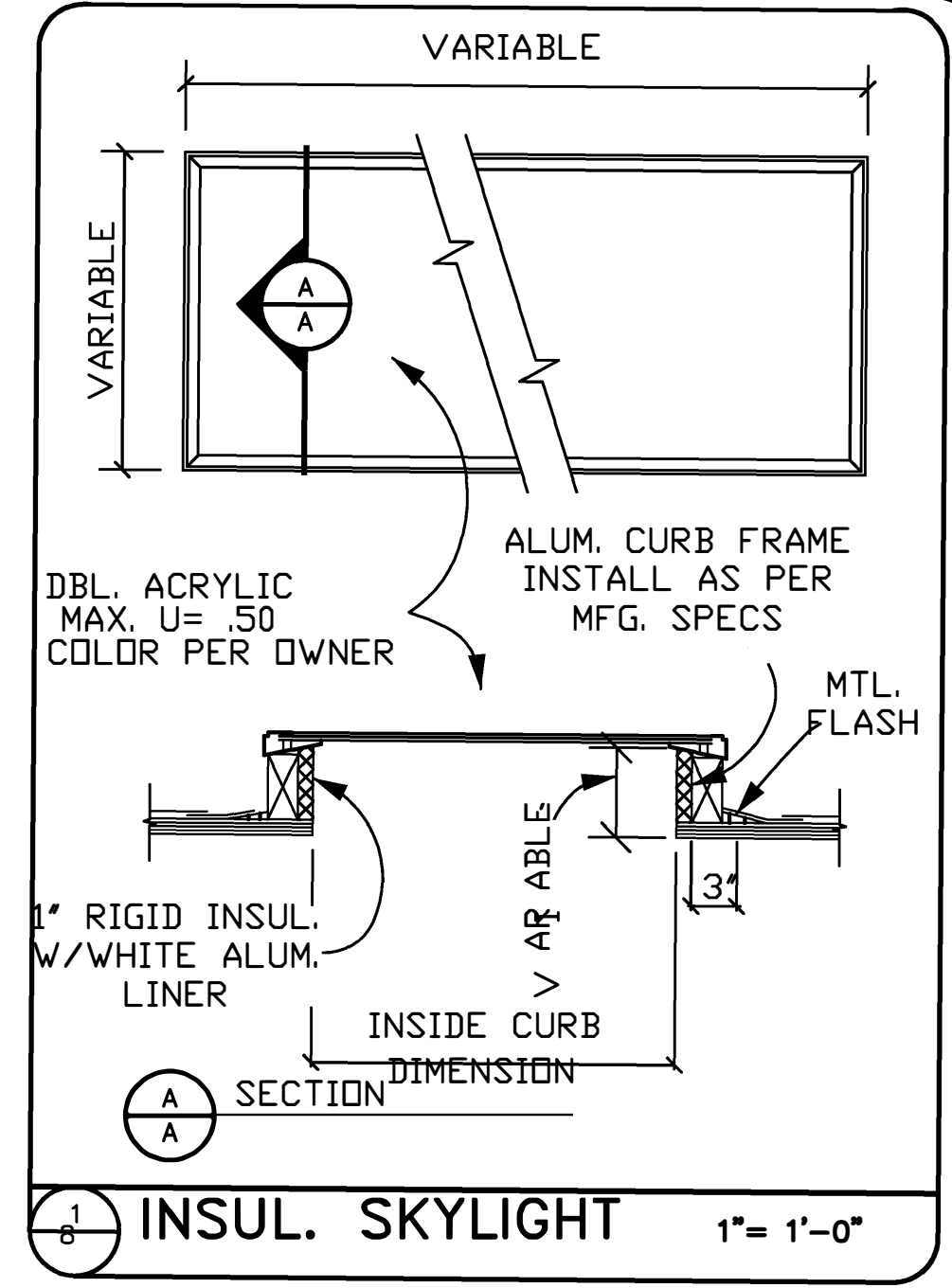

INSUL. SKYLIGHT 1"= 1'-0"

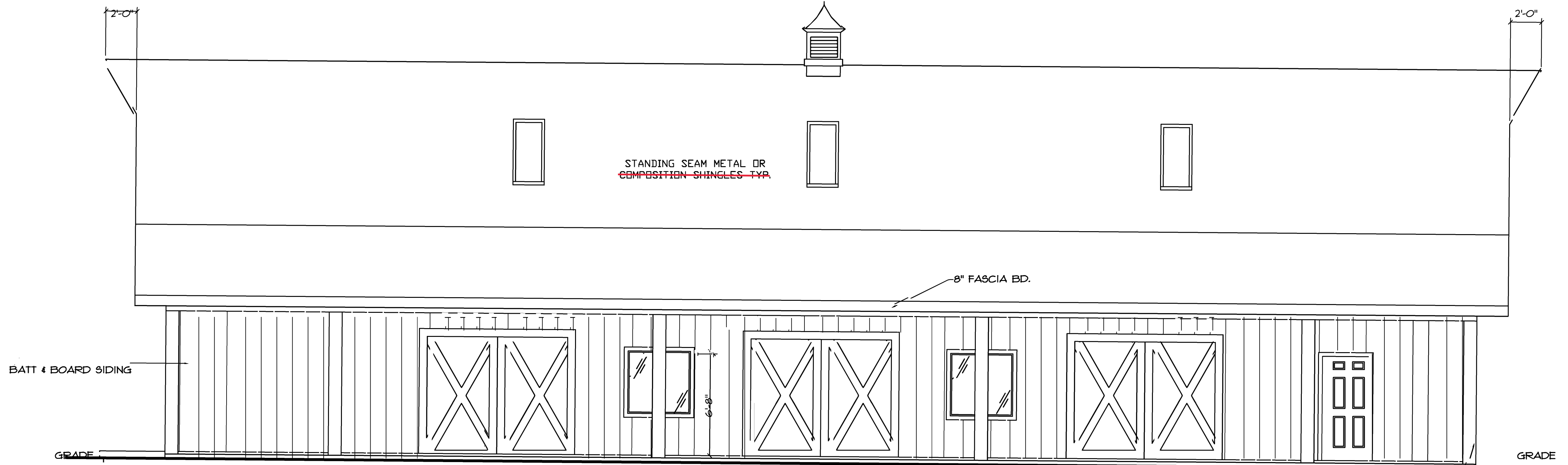

RIGHT SIDE ELEVATION
SCALE: 1/2"=1'-0"

REVISIONS	BY

NEW SHOP DR:
MRS. TO LER

Great House Design
25119 N. Aspen Grove Lane
Colbert Washington 99005
website - www.greathousedesign.net

PH # (509) 276-3800 FX # (509) 276-5426 E-MAIL - info@greathousedesign.net (Copyright Great House Design)
"IF YOU CAN DREAM IT, WE CAN DESIGN IT."
FRONT & RIGHT SIDE ELEVATIONS
"IF YOU CAN DREAM IT, WE CAN DESIGN IT."

- NOTES:
- 1) ALL ROOF AND SITE WATER TO ~~grade to daylight~~ **be buried and run down** OR TO AN APPROVED DRY-WELL SYSTEM.
 - 2) ALL NAILING TO BE IN COMPLIANCE W/ 2015 I.R.C.
 - 3) SHEARWALL NAILING TO BE: 4"D.C. ON EDGE 8"D.C. IN FIELD
 - 4) EXPOSED PLYWOOD AT ROOF OVERHANG TO BE CC-X OR BETTER.

Date	7/2017
Scale	1/4"=1'-0"
Drawn	GPH
Job	4043
Sheet	1
Of	8 Sheets

REVISIONS	BY

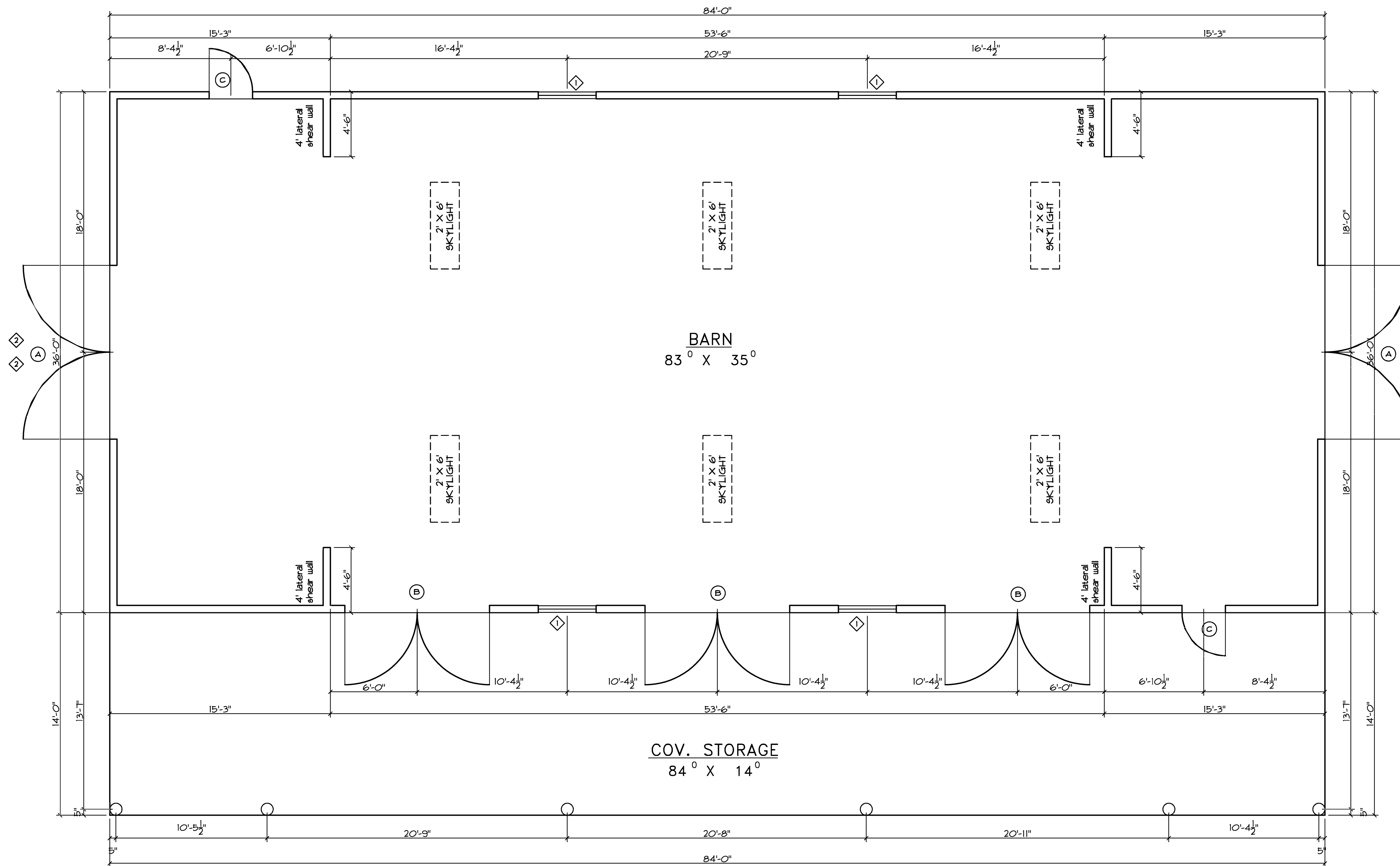

BARN LEVEL FLOOR PLAN

SCALE: 1/4"=1'-0"

2015 ENERGY CODE PRESCRIPTIVE REQUIREMENTS FOR GROUP R OCCUPANCY CLIMATE ZONE 5											
OPTION	GLAZING FLOOR AREA	GLAZING U-FACTOR VERTICAL	GLAZING U-FACTOR OVERHEAD	ROOF U-FACTOR	CEILING	VAULTED CEILING	WALL INT. FRAME	WALL EXT. FRAME	WALL EXT. SHELF FRAME	FLOOR	SLAB ON GRADE
I	100	0.32	0.36	0.09	R-30	R-30	R-10	R-10	R-10	R-30	R-10
II	100	0.35	0.39	0.09	R-30	R-30	R-10	R-10	R-10	R-30	R-10
IV	UNLIMITED	0.30	0.30	0.09	R-10	R-10	R-10	R-10	R-10	R-30	R-10

WINDOW SCHEDULE						
SYM	SIZE	MANUF	MAT	GLAZING	OPER	QUAN REMARKS
◇	4040	CHK/ALI OWNER	CHK/ALI OWNER	CHK/ALI OWNER	SLIDING	4
◇	CUSTOM				CUSTOM	4 SEE ELEVATIONS

DOOR SCHEDULE						
SYM	SIZE	CORE	MAT	HRDURE	FINISH	QUAN REMARKS
(A)	12' x 12'	SC	CHK/ALI OWNER	LOCKS	CHK/ALI OWNER	2 HINGED BARN DOOR
(B)	10' x 8'	SC		LOCKS		3 HINGED BARN DOOR
(C)	3068	FF		BOLTS		2 ENTRY

SQUARE FOOTAGE

GARAGE 3024 SQ. FT.
COV. STORAGE 1176 SQ. FT.

PH # (509) 276-3800 FX # (509) 276-5426 E-MAIL - info@greathousedesign.net (Copyright Great House Design)

NEW SHOP FOR:
MRS. TOLER

Great House Design
25119 N. Aspen Grove Lane
Colbert, Washington 99005
website - www.greathousedesign.net

"IF YOU CAN DREAM IT, WE CAN DESIGN IT."

**BARN LEVEL
FLOOR PLAN**

Date	6/2017
Scale	1/4"=1'-0"
Drawn	GPH
Job	4043
Sheet	3
Of	8 Sheets

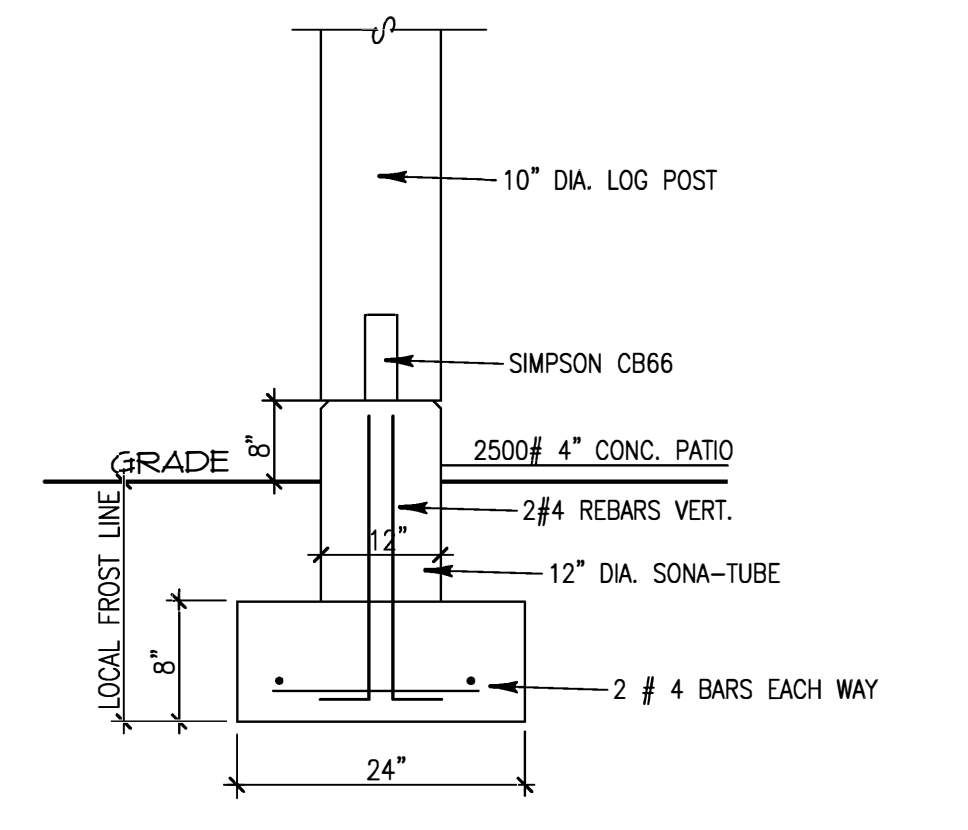
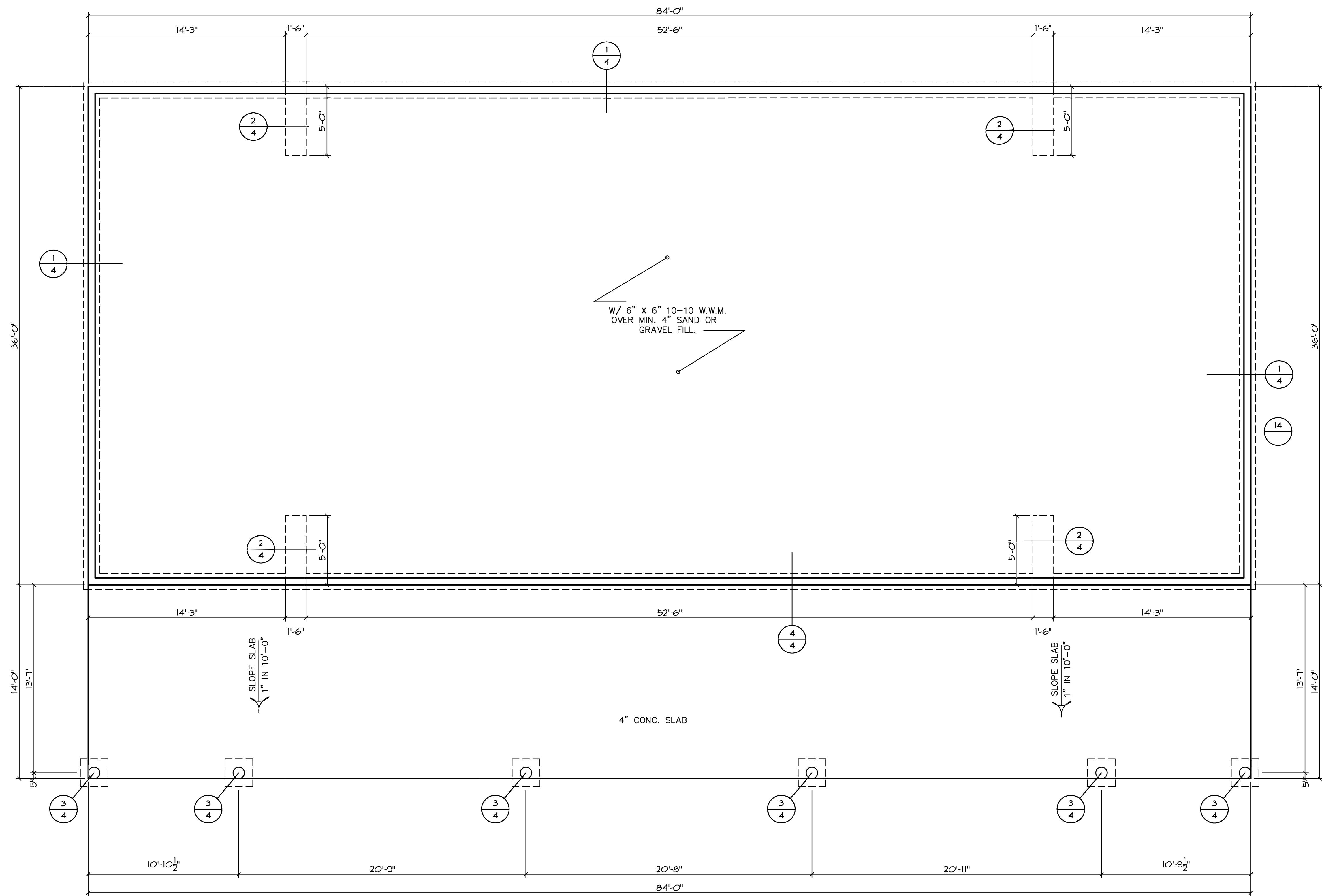

STANDARD DECK FOOTING
SCALE: NTS

FOUNDATION NOTES

- FOOTINGS ARE TO BEAR ON UNDISTURBED LEVEL SOIL DEVOID OF ANY ORGANIC MATERIAL AND STEPPED AS REQUIRED TO MAINTAIN THE REQUIRED DEPTH BELOW THE FINAL GRADE.
- SOIL BEARING PRESSURE ASSUMED TO BE 1500 PSF.
- ANY FILL UNDER GRADE SUPPORTED SLABS TO BE A MINIMUM OF 4" GRANULAR MATERIAL COMPACTED TO 95%.
- CONCRETE:
 - BASEMENT WALLS & FOUNDATIONS NOT EXPOSED TO WEATHER : 2500 PSI
 - BASEMENT & INTERIOR SLABS ON GRADE : 2500 PSI
 - BASEMENT WALLS & FOUNDATIONS EXPOSED TO THE WEATHER : 2500 PSI
 - PORCHES, STEPS & CARPORT SLABS EXPOSED TO WEATHER : 2500 PSI
- CONCRETE SLABS TO HAVE CONTROL JOINTS AT 25' (MAXIMUM) INTERVALS EA. WAY.
- CONCRETE SIDEWALKS TO HAVE 1/2" TOOLED JOINTS AT 5' O.C. (MINIMUM)
- REINFORCING STEEL TO BE A-615 GRADE 60, WELDED WIRE MESH TO BE A-185.
- ALL WOOD IN CONTACT WITH CONCRETE TO BE PRESSURE TREATED OR PROTECTED WITH 55# ROLL ROOFING.

FOUNDATION PLAN
SCALE: 1/4"=1'-0"

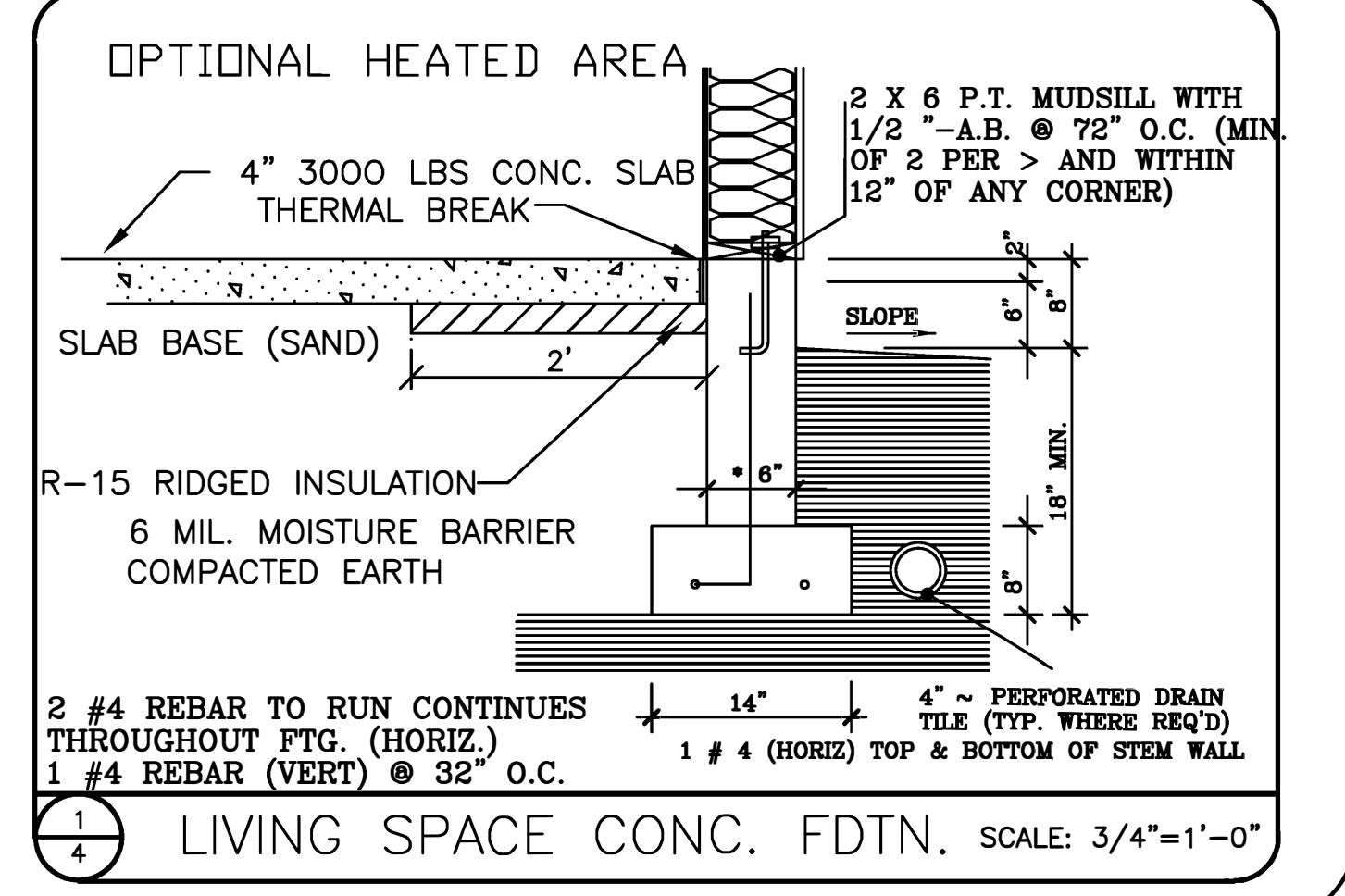
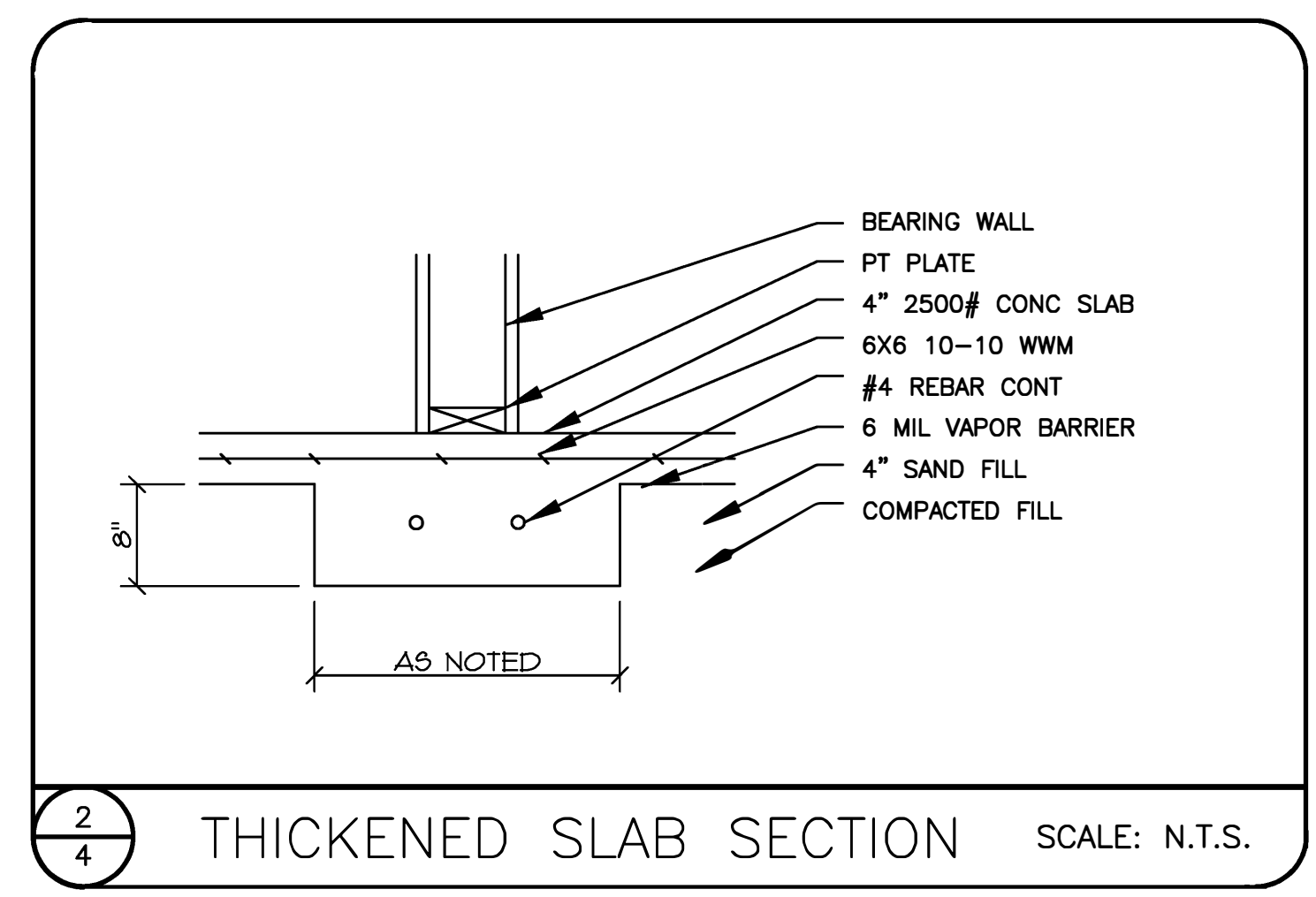
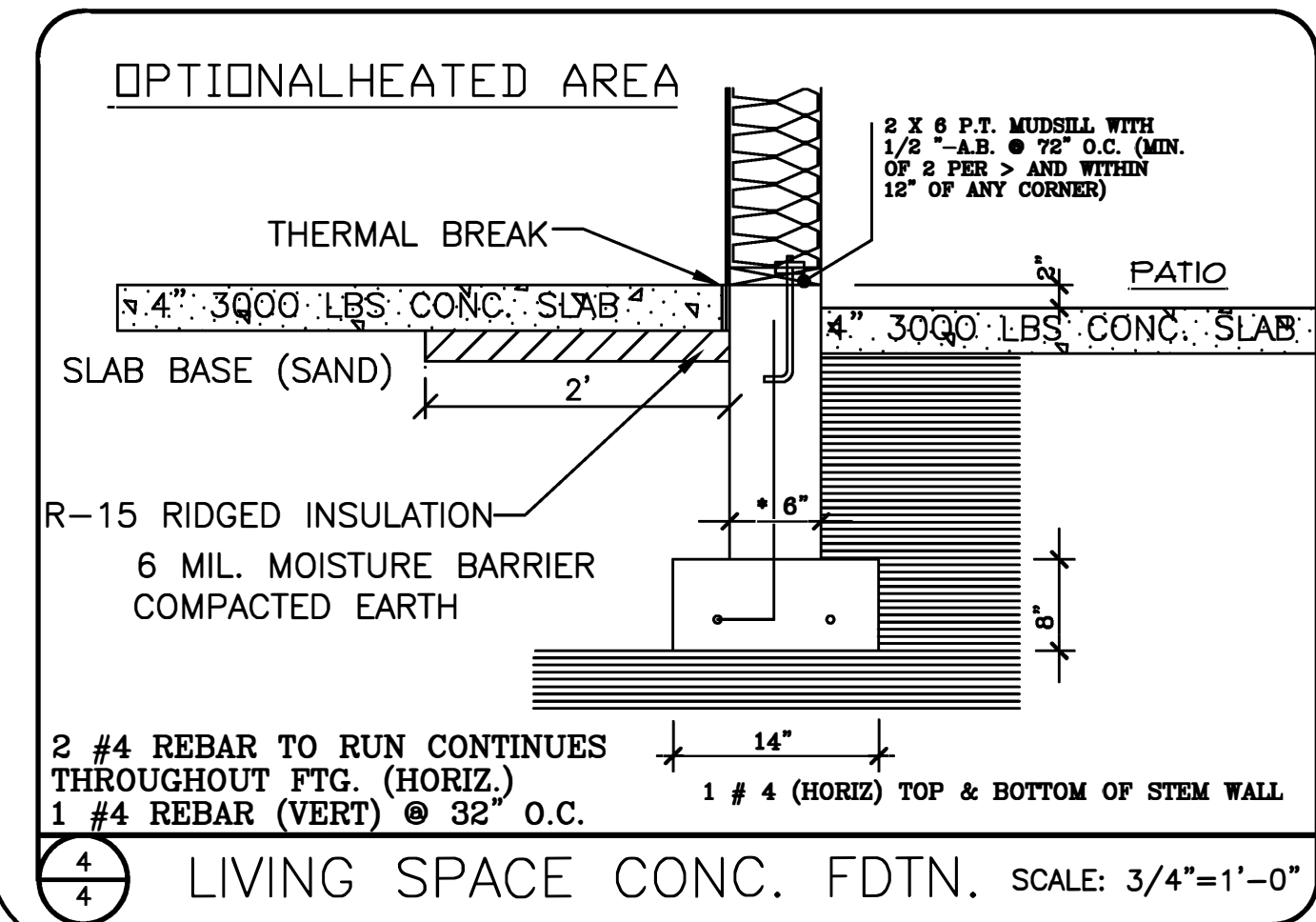

REVISIONS	BY

NEW SHOP FOR:
MRS. TOLER

Great House Design
25119 N. Aspen Grove Lane
Colbert, Washington 99005
website - www.greathousedesign.net

FOUNDATION PLAN

Date	7/2017
Scale	1/8"=1'-0"
Drawn	
Job	4043
Sheet	4
Of	8 Sheets

PH # (509) 276-3800 FX # (509) 276-5426 E-MAIL - info@greathousedesign.net Copyright Great House Design

"IF YOU CAN DREAM IT, WE CAN DESIGN IT."

"IF YOU CAN DREAM IT, WE CAN DESIGN IT."

REVISIONS	BY

NEW SHOP FOR:
MRS. TOLER

Great House Design
25119 N. Aspen Grove Lane
Colbert, Washington 99005
website - www.greathousedesign.net

PH # (509) 276-3800 FX # (509) 276-5426 E-MAIL - info@greathousedesign.net (Copyright Great House Design)
ROOF FRAMING PLAN

Date	7/2017
Scale	1/8"=1'-0"
Drawn	
Job	4043
Sheet	5
Of	8 Sheets

ENGINEERED SCISSOR TRUSSES @ 24" O.C.

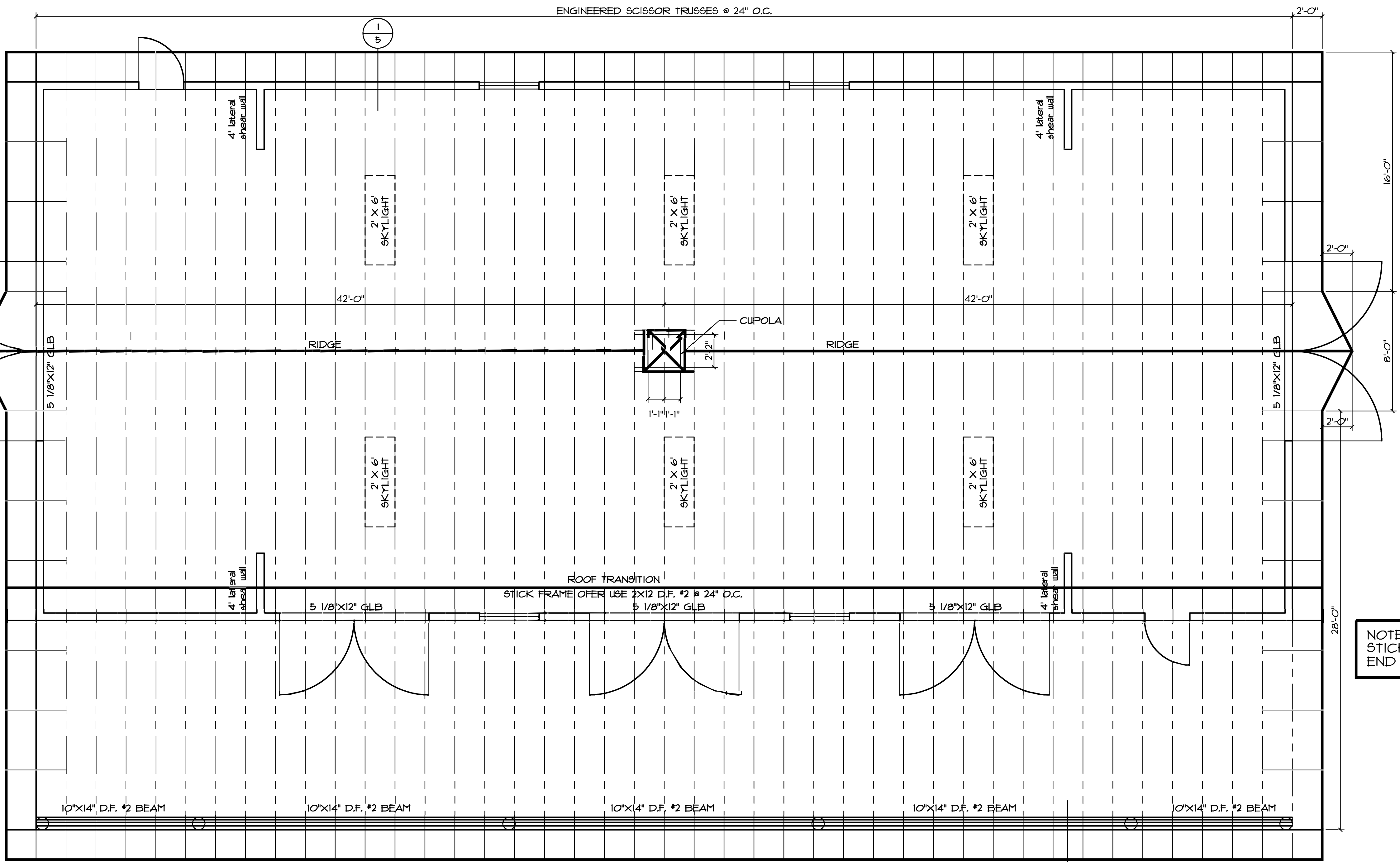

ROOF VENTING 22.3 SQ. FT. REQ'D.
PROVIDE CONTIN. EAVE VENTS AND CONTIN. RIDGE VENTS OR 8" X 8" JACKS AS REQ'D. TO PROVIDE CROSS VENTILATION.

- NOTES:**
- 1) USE METAL FASTENERS AT ALL BEAMS TO SUPPORT MEMBERS
 - 2) ~~PROVIDE 30" X 22" ATTIC ACCESS~~
 - 3) PROVIDE SOLID BLOCKING AT ALL BEARING PARTITIONS *BY TRUSS CLIPS ONLY*
 - 4) TRUSSES TO BE CONNECTED TO NON-BEARING PARTITIONS *BY TRUSS CLIPS ONLY*
 - 5) GLUE LAMINATED BEAMS TO BE WESTERN SPECIE COMBINATION 24F V-4 PER ANSI/AITC A190.1-1992 OR EQUAL.
 - 6) TRUSS MFG. TO VERIFY ALL DIMENSIONS PRIOR TO CONSTRUCTION

NOTE: STICK FRAME GABLE END WALLS

NOTE: STICK FRAME GABLE END WALLS

ROOF FRAMING PLAN
SCALE 1/4"=1'-0"

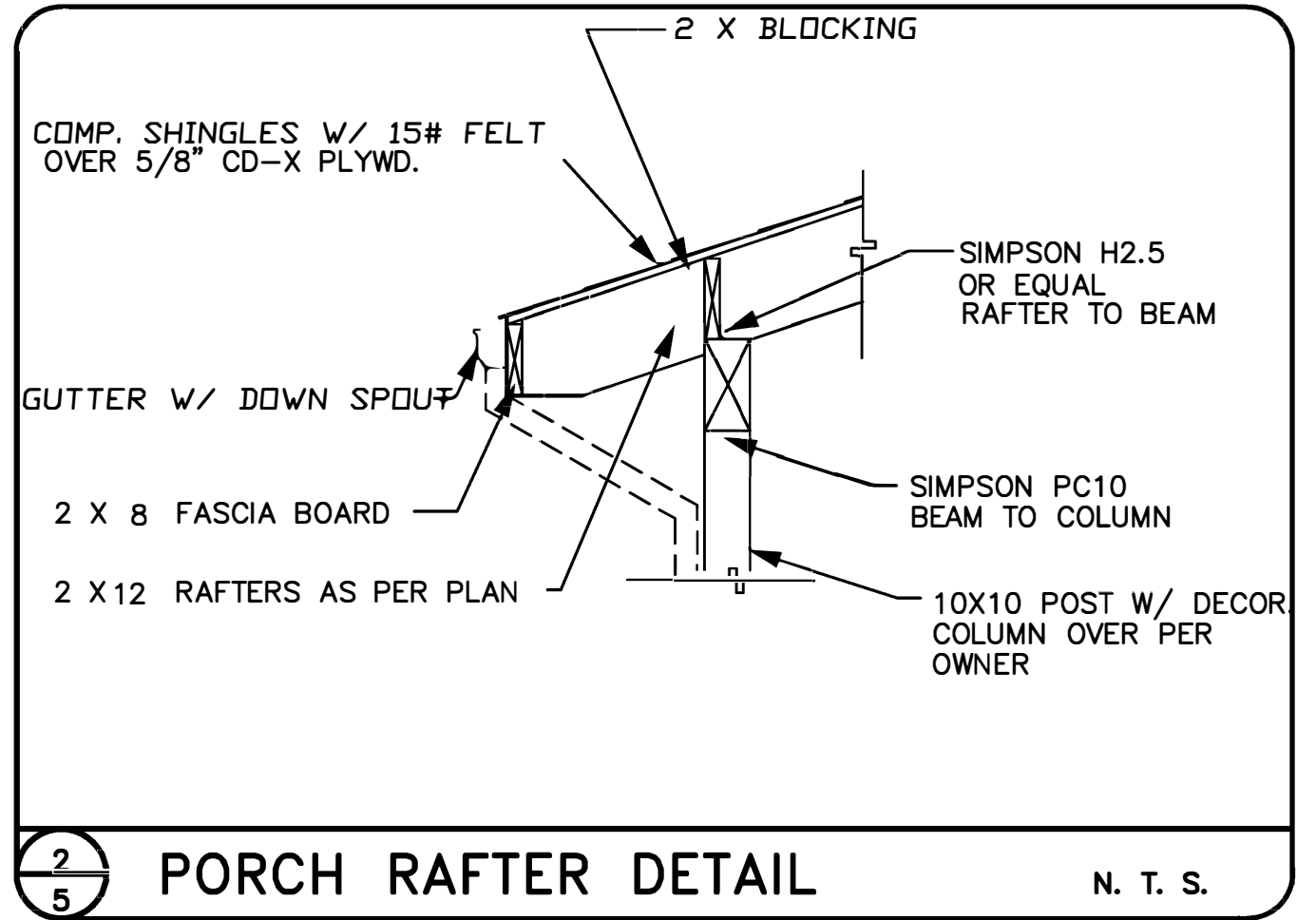
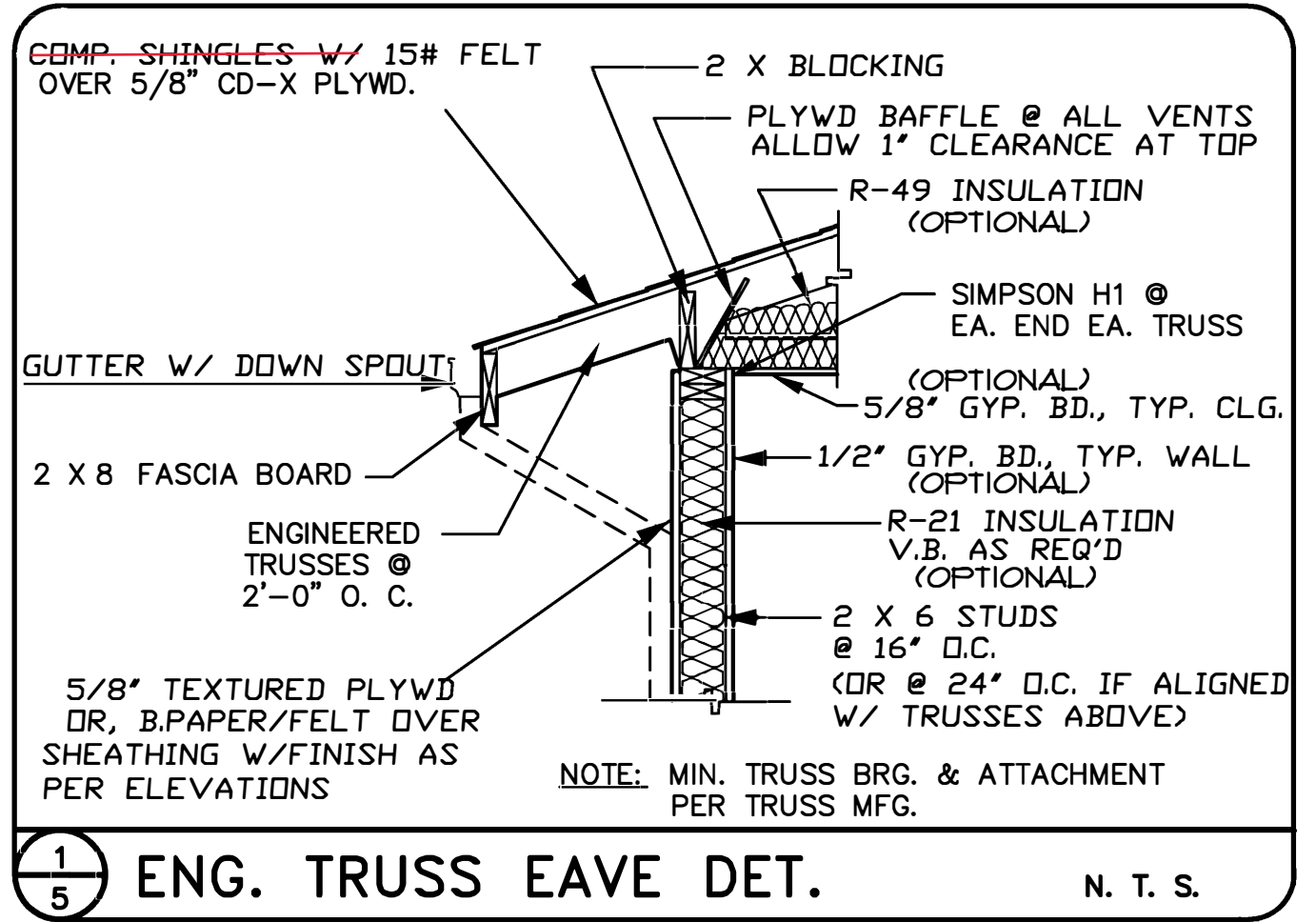

HEADER SCHEDULE

NOTE:
HEADERS #2 D.F. OR BETTER

UP TO 4'	2-2X8
4' TO 6'	2-2X10
6' TO 8'	2-2X12
OVER 8' AS DETAILED	

GLUED & NAILED

SEE TABLE R502.5 (1) FOR JACK STUD REQUIREMENTS

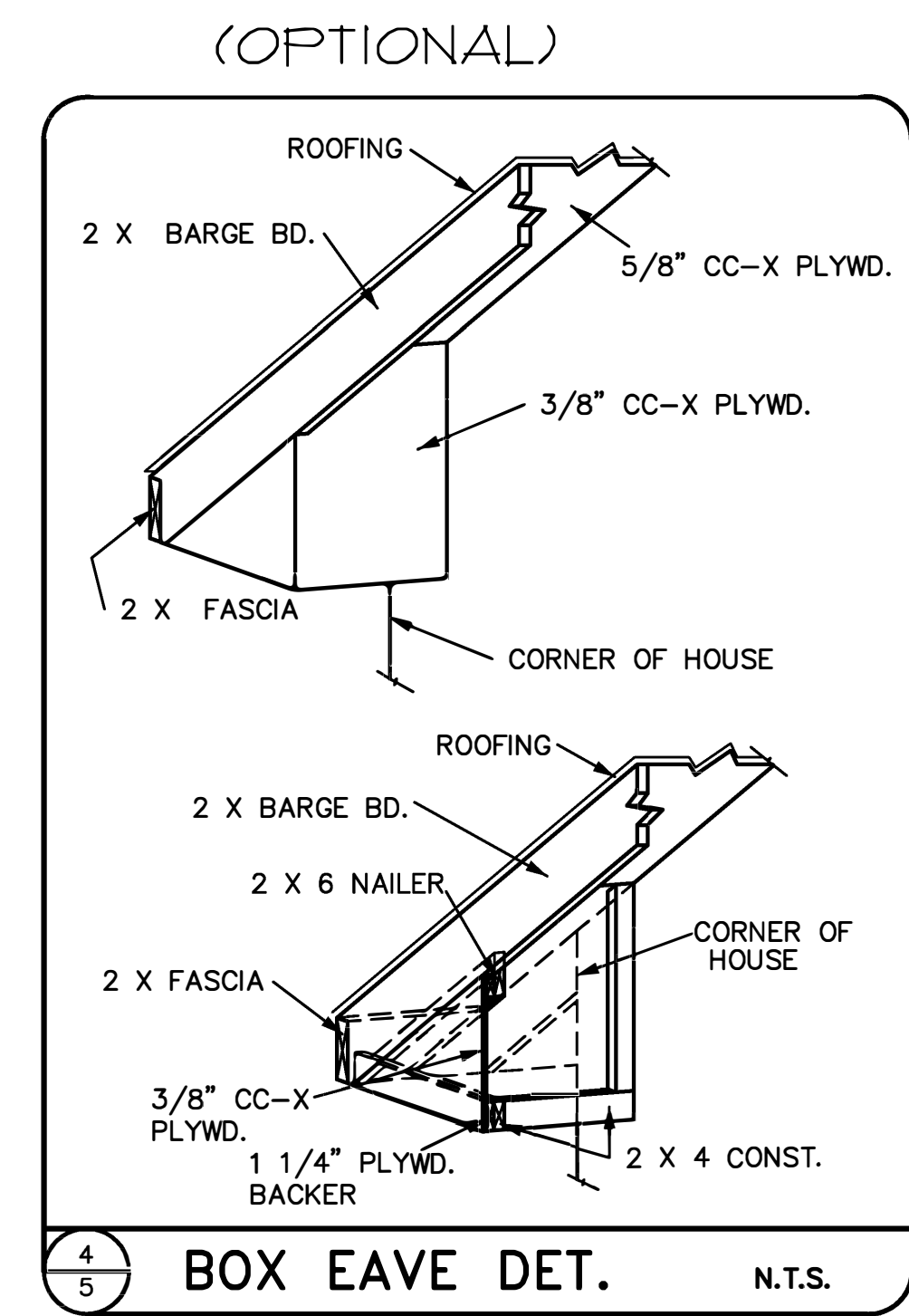
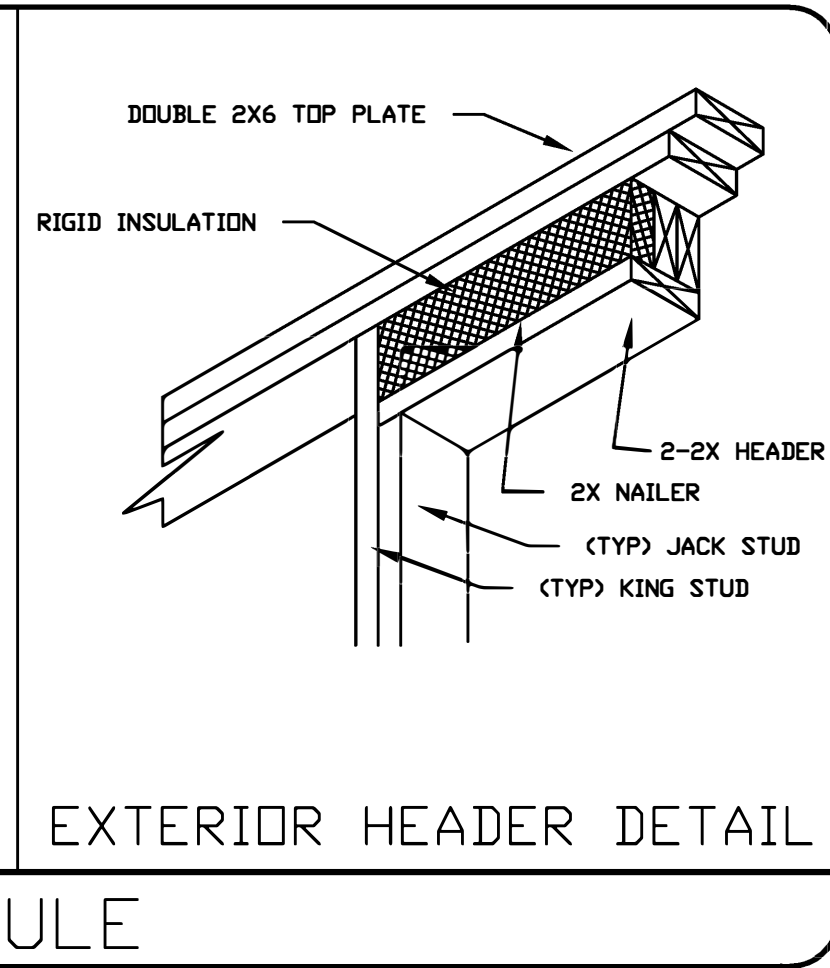

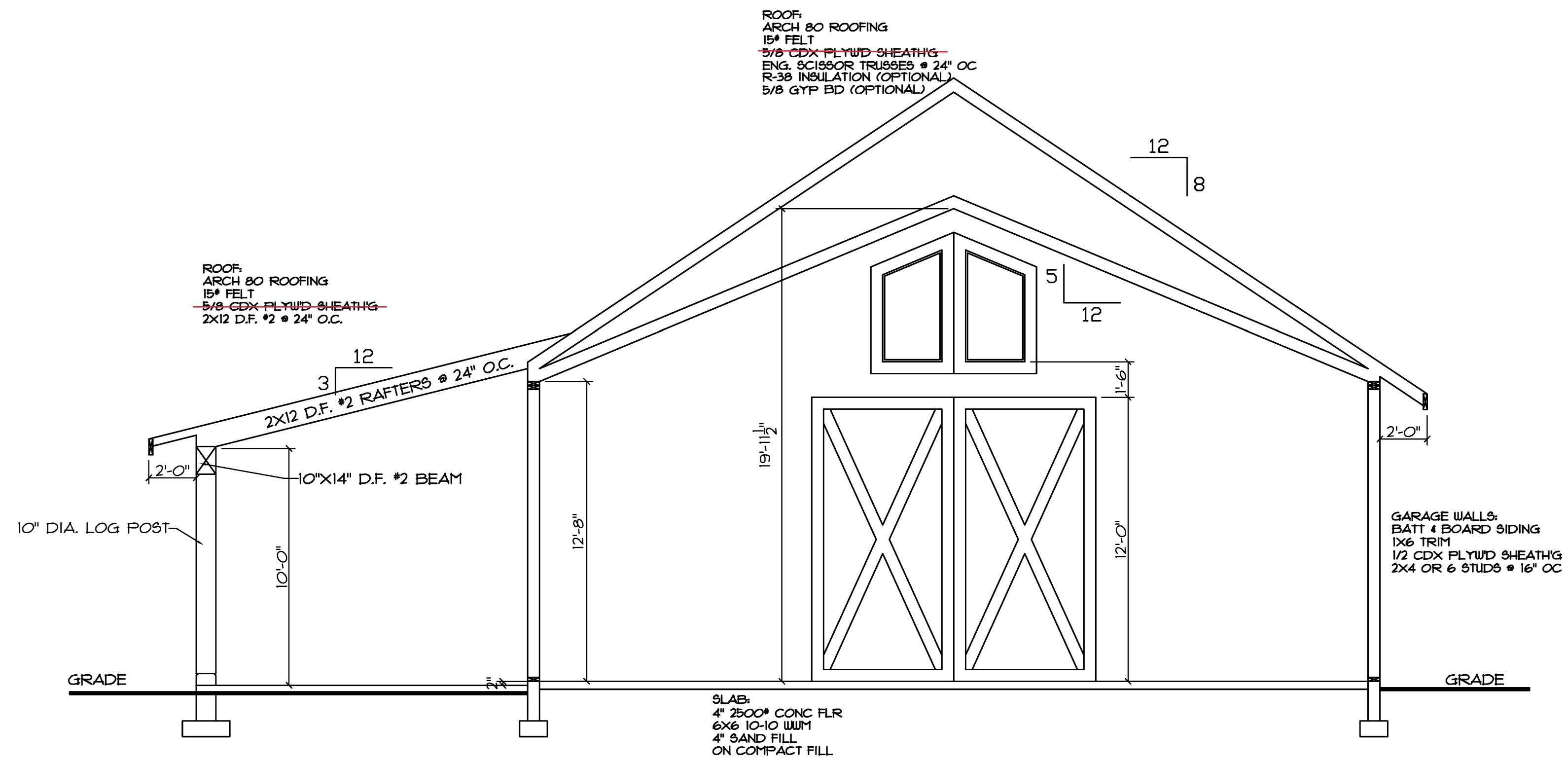

CROSS SECTION AA
SCALE: 1/4"=1'-0"

REVISIONS	BY

PH # (509) 276-3800 FX # (509) 276-5426 E-MAIL - info@greathousedesign.net (Copyrht Great House Design)

NEW SHOP FOR:
MRS. TOLER

Great House Design
25119 N. Aspen Grove Lane
Colbert, Washington 99005
website - www.greathousedesign.net

"IF YOU CAN DREAM IT, WE CAN DESIGN IT."
CROSS SECTIONS
"IF YOU CAN DREAM IT, WE CAN DESIGN IT."

Date	7/2017
Scale	1/8"=1'-0"
Drawn	
Job	4043
Sheet	6
Of	8 Sheets

REVISIONS	BY

NOTE: ALL OUTLETS ARE TO BE GFCI.

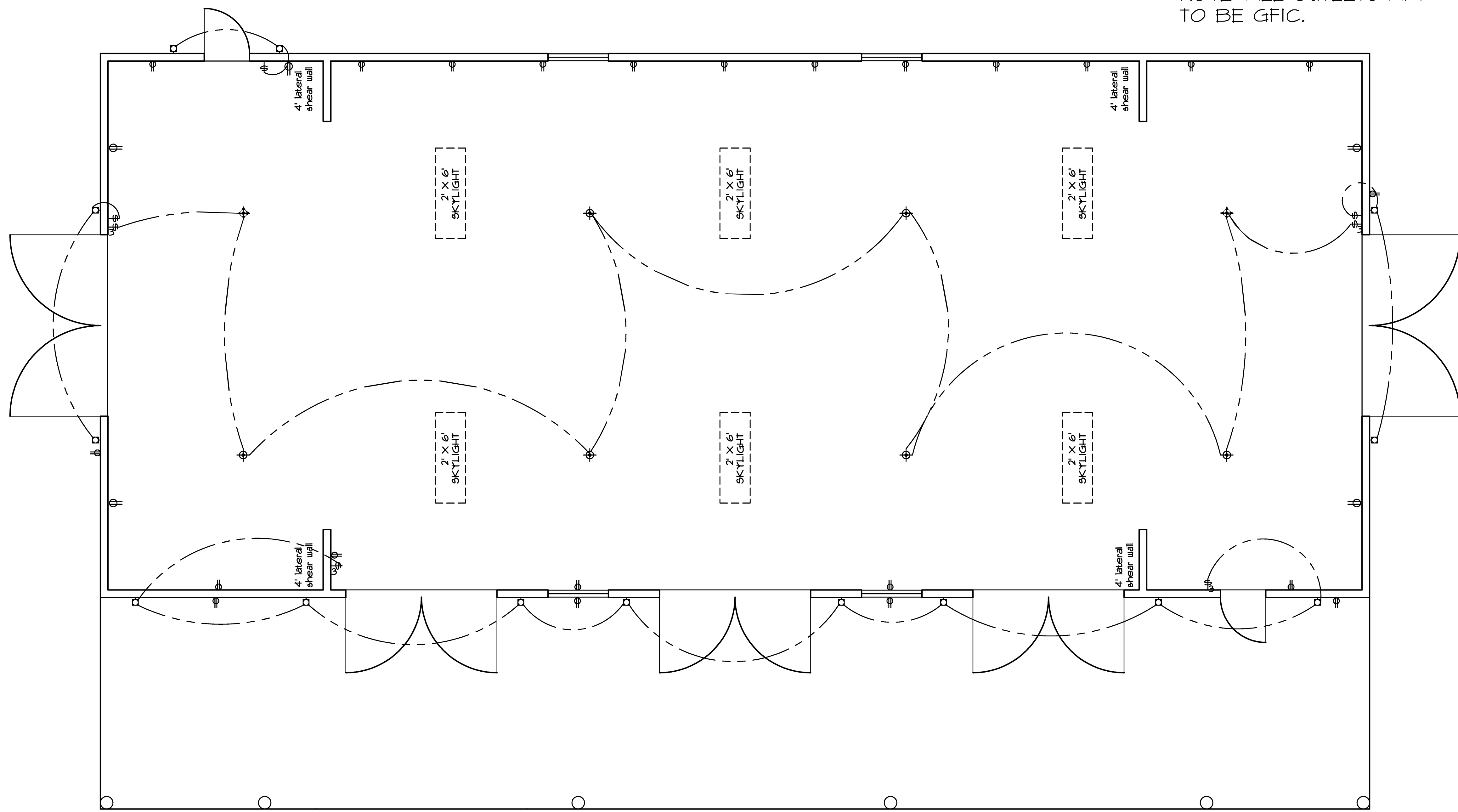

LEGEND

- ⊖ WALL SWITCH
- ⊕ 110V OUTLET
- ⊕ QUADRUPLEX OUTLET
- ⊕ HALF SWITCHED OUTLET
- ⊕ 220V OUTLET
- ⊕ CEILING MTD. LIGHT FIXTURE
- ⊕ EXTERIOR WALL MTD. LIGHT FIXTURE
- ⊕ BATHROOM FAN/LIGHT FIXTURE
- ⊕ PHONE OUTLET
- ⊕ COMPUTER OUTLET
- ⊕ THERMOSTAT
- ⊕ CADET HEATER
- ⊕ SMOKE DETECTOR TO BE HARDWRED
- ⊕ RECESSED LIGHTING

NOTES:

- 1) GROUND FAULT CIRCUIT PROTECTION REQ'D ON ALL 110 VOLT SINGLE PHASE 15&20 AMP OUTLETS IN BATHROOMS, GARAGES, OUTDOORS, BASEMENTS, & WITHIN SIX FEET OF KITCHEN SINK & ABOVE COUNTER TOPS. (N.E.C. 210-8a)
- 2) REBAR GROUNDING- 1993 ELECTRICAL SPECIALTY CODE, ARTICLE 250-81 REQUIRES CONCRETE REINFORCING BARS OR RODS TO BE PART OF THE GROUNDING ELECTRODE SYSTEM WHEN USED ON NEW CONSTRUCTION IN THE BUILDING FOOTINGS.
- 3) CONTRACTOR TO VERIFY ALL DIMENSIONS PRIOR TO CONSTRUCTION.
- 4) LOW VOLTAGE LIGHTING WERE POSSIBLE
- 5) VERIFY ALL ELEC., T.V. & PHONE OUTLETS W/OWNER BEFORE INSTALLATION
- 6) P PHOTOELECTRICALLY ACTIVATED

SHOP LEVEL ELECTRICAL PLAN
SCALE 1/4"=1'-0"

PH # (509) 276-3800 FX # (509) 276-5426 E-MAIL - info@greathousedesign.net (Copyright Great House Design)

NEW SHOP FOR:
MRS. TOLER

Great House Design

25119 N. Aspen Grove Lane
Colbert, Washington 99005

website - www.greathousedesign.net

"IF YOU CAN DREAM IT, WE CAN DESIGN IT."

SHOP LEVEL ELECTRICAL PLAN

"IF YOU CAN DREAM IT, WE CAN DESIGN IT."

Date	7/2017
Scale	1/4"=1'-0"
Drawn	GPH
Job	4043
Sheet	1
Of	8 Sheets

GENERAL NOTES

These plans were designed to conform to the 2015 International Residential Code and C.A.B.O. at the time the plans were drawn. Constant changes in building codes, both locally and nationally, in addition to changes in environmental qualifications and local options for plumbing, heating/cooling and wiring, makes conformity to all building restrictions impossible. Consequently, the use of these plans is subject to local code requirements and interpretations. It is the responsibility of the user to evaluate these plans for conformity to local codes requirements. Any additional design or drawing services required by local code are subject to Great House Design standard service fees.

The Contractor shall verify all dimensions and conditions prior to beginning any work and notify Owner of any discrepancies.

Written dimensions shall take precedence over scaled dimensions. DO NOT SCALE DRAWINGS.

Great House Design, does not guarantee the availability of any manufactured product suggested or specified on the plans or specifications. The builder is advised to verify the availability of all manufactured products before proceeding with construction, especially those items affecting rough opening dimensions or other dimensions on the plans. All manufactured materials, components, fasteners, assemblies, etc., shall be handled and installed in conformance with manufacturers specifications and instructions. Where specific products are called for, generic equivalence which meet applicable standards and specifications may be used.

In event of a conflict between applicable codes and regulations and reference standards of these plans and specifications, the more stringent provisions shall govern.

No variation required by a Building Official shall be binding on the Designer.

Specifications and drawings indicate finished structure. Builder shall be responsible for construction methods, procedures and conditions except as specifically indicated otherwise in contract documents.

DESIGN LOADS

DEAD LOADS:

Roof, with shakes/shingles	10psf
Roof, with clay/concrete tiles {see plan for material used}	25psf
Floor	10psf

LIVE LOADS:

Floor	40psf
Stairs	100psf
Decks	40psf
Garage	50psf or 2000 pt.l.d.
Roof SL	50 psf

INSULATION:

Roof	R-30
Vaulted Areas	R-30
Flat Ceilings	R-19
Exterior Walls	R-19
Floors over unheated spaces	R-30
Basement walls	R-19
Slab floor edge insulation	R-15 Rigid Insulation
Forced air duct insulation	R-8

Windows:
U= 0.28

Skylights <2%
U= 0.50

Doors other than main entry
U= 0.20

Main entry door, Maximum 24 sq. ft.
U= 0.54

FOUNDATIONS:

- Footings shall bear on firm, undisturbed soil a minimum of 18" below the finish grade line and 12" below the line of the original grade for one and two story structures, and 24" below finish grade for three-story structures, or below frost line. (whichever is greater)
- Foundation and footing sizes are based on a maximum allowable soil bearing pressure of 1500 psf. Verify local conditions and notify owner of any discrepancy.
- Do not excavate greater than a 1-1/2:2 slope below footings.
- Footings to extend below frost line or 18" below finish grade, whichever is greater.

CONCRETE:

- All foundation wall and footing concrete shall develop a minimum compressive strength of 2500 psl @ 28 days.
- All concrete slabs shall develop a minimum compressive strength of 2,500 psl at 28 days. Concrete forms, shoring and pouring methods shall conform to current A.C.I. standards.
- Back fill shall not be placed against basement retaining walls until:
 - Concrete or masonry grout has reached its 28 day strength, and + -
 - Structural floor framing {including sub-floor} required to stabilize walls is complete and fully nailed and anchored.
- Apply Standard Dry Wall Products, Inc. "Thoroseal Foundation Coating" or equal foundation coating on all exterior faces of walls below grade, and "Thoroglaze" or equal damp proofing on all exposed surfaces of concrete walls above grade and all slabs not covered by finish floor materials.

REINFORCING STEEL:

- All reinforcing steel shall be deformed steel bars conforming to ASTM A615, GRADE 60.
- All reinforcing steel shall be manufactured detailed, fabricated and placed in accordance with ACI 318R, ACI 315R AND ACI SP 66.
- Welded wire fabric shall conform to ASTM A185, In as long a length as is practicable. Welded wire fabric shall be lapped at least one grid width plus 2".
- Reinforcement shall be bent cold and shall not be welded.
- Splices:

reinforcement in concrete and masonry shall have lap lengths as follows, unless otherwise specified on drawings.

Bar Size	In Concrete:	In Masonry:
#3	1'-6"	2'-0"
#4	2'-0"	2'-6"
#5	2'-6"	3'-0"

Placement:

- Reinforcement shall be accurately placed and supported by concrete, metal or other approved chairs, spacers or ties and secure against displacement during concrete or grout placement.
- Except where otherwise noted reinforcement shall have concrete cover as follows:
 - Concrete deposited against earth 3"
 - Formed concrete against earth 2"
 - Exterior faces of walls 2"
 - Interior faces of walls 3/4"
 - To top of slabs-on-grade 3/4"

WOOD FRAMING:

All solid sawn lumber shall be Douglas Fir / Larch installed as noted on the plans and connected as specified in the nailing schedule below. Lumber shall be as graded in accordance with current Western Wood Products Association [WWPA] standard grading rules. Lumber grades for uses to be:

A. Posts, Beams & Headers	#2
B. Floor, Ceiling Joists, & Rafters	#2 or better
C. Sills, Plates & Blocking	#2
D. Studs	D.F. "stud"
F. Wall & Roof Sheathing	Plywood 16/32
G. Sub-Floor over Joists	3/4" C-D ext. glue
H. Underlayment	1/2" underlayment grade particleboard
I. Glu-Laminated Beams	FB =2,400 psi
A.I.T.C. Industrial Grade with dry use adhesive.	FV =190 psi
{Wet use adhesive for exterior use}	E =1,800,000 psi

Solid sawn lumber at visually exposed locations shall be "clear" grade, free of heart. All exterior wall & interior bearing wall openings shall have 4 x 12 #1 D.F./1 headers unless otherwise noted.

NAILING SCHEDULE:

CONNECTION:

Joist to Sill or Beam
Bridging to joists
2" T&G Decking/Sub-Floor to Beams
Rim Joist to Joists
Studs to sole plate
Sole Plate to Joists or Blocking
Sole Plate or Top Plate to Studs
Double Top Plate
Double Studs
Corner Studs
Top Plates At Laps & Intersection
Headers to Top Plates
Ceiling Joists to Plates
Joist Laps over Partitions
Ceiling Joists to Plates
Rafters to Top Plate

Plywood Sub-Floor to joists

Plywood Wall & Roof Sheathing

NAILING:

{3}	8d Toe Nailed
{2}	8d Toe Nailed Ea. End
{2}	16d Toe Nail through Tongue
{3}	16d Face Nailed
{2}	16d Face Nailed Ea. End
{1}	16d at 16" o.c. Face Nailed
{2}	16d Face Nailed
{1}	16d at 16" O.c. Face Nailed
{1}	16d at 16"O.c. Face Nailed
{1}	16d at 16"O.c. Face Nailed
{2}	16d Face Nailed
{1}	16d at 16"O.c. Face Nailed
{3}	8d Toe Nailed
{3}	16d Face Nailed
{3}	16d Face Nailed
{3}	8d Toe Nailed with "Simpson"
	H-25 Connectors-Verify
{1}	10d Common at 6" o.c. at edges
	& 10" o.c. in field
{1}	8d Common at 6" o.c. at edges & 12" o.c. in field

NAILING SCHEDULE NOTES:

- All frame walls shall have stud framing placed at 16"o.c. except where otherwise noted.
- Top plates shall be doubled on all walls except where otherwise noted.
- Cripples under all headers shall be continuous to sole plate.
- Double joists under all walls parallel to joists except where otherwise noted.
- Block all stud walls as required for sheathing.
- Solid Blocking between all joists and rafters at supporting walls and beams except at rim joists.
- Double rim joists at all walls parallel to joists.
- Beams, girders and joists supporting bearing walls or concentrated loads shall not be notched.
- All rafters shall not be notched to provide full bearing at supports.
- All joists shall have a minimum of 2" bearing @ supports.
- Lap all joists 6" minimum @ all interior bearing supports
- Mud sills and ledger boards at concrete walls shall have anchor bolts of the size and spacing shown on the drawing. Each board shall be secured with at least two bolts and each board shall have a bolt within 12" of each end.
- Cover surfaces behind siding, shingles and where indicated on drawings with DuPont "Tyvek" building wrap, or and approved equivalent product
- Provide double framing at all roof & floor diaphragm penetration unless otherwise noted on plans.

MISCELLANEOUS:

- Contractor shall verify all conditions and dimensions prior to beginning work and shall notify owner of any discrepancy.
- Contractor shall be responsible for any variations or deviations from the plans without written confirmation from Designer.
- Contractor shall provide adequate bracing or otherwise support all portions of the structure until all members have been permanently connected together.
- Plumbing diagrams or drawings shall be provided by the plumbing contractor.
- Heating/Cooling duct diagrams or drawings shall be provided by the heating/cooling contractor.
- Heat loss or energy use calculations shall be provided by heating cooling contractor or other professional as required by Building Official.
- Truss design, engineering and plans shall be provided by truss manufacturer.
- Each bedroom shall have at least one window with a sill height of no more than 44" above the floor.
- All fireplace openings shall be provided with tempered glass doors. Provide outside combustion air for fireplaces, wood stoves and liquid fuel heating appliances.
- Smoke detectors shall be connected to house power.
- Tub and shower enclosures to have 1/2" water resistant gypsum board and a hard, moisture resistant surface up to 6'-0" above floor [min].
- All exhaust fans, range hoods and dryers shall vent to the outside through sheet metal ducts. Caulk around all penetrations through exterior envelope.
- All windows, patio doors and doors with glass shall be double glazed insulating units with wood, vinyl or thermally broken aluminum frames and sashes.
- All glass within 12" of a door and/or within 18" of the floor or a walkway shall have tempered glazing.
- All wood in permanent contact with concrete or soil shall be pressure treated with a water born preservative.
- All exterior walls & walls common to unheated spaces shall be 2x6 studs @ 16" o.c. with R-21 insulation unless otherwise noted on the plans.
- Provide 1 hr. fire wall between garage and living areas, and under all stairs where storage space is available.
- All doors between garage and living areas shall be 1 hr. fire rated assemblies with 1-3/4" solid core wood doors or code approved equivalence and self-closing mechanisms.
- Please call this office at [509] 276-3800 for any questions relating to these plans.

REVISIONS	BY

NEW SHOP FOR:
MRS. TOLER

Great House Design
25119 N. Aspen Grove Lane
Colbert, Washington 99005
website - www.greathousedesign.net

IF YOU CAN DREAM IT, WE CAN DESIGN IT.
GENERAL NOTES
IF YOU CAN DREAM IT, WE CAN DESIGN IT.

Date	7/2017
Scale	
Drawn	BJA
Job	4043
Sheet	8
Of	8 Sheets

PH # (509) 276-3800 FX # (509) 276-5426 E-MAIL - info@greathousedesign.net (Copyright Great House Design)



COUNTY OF FLUVANNA

“Responsive & Responsible Government”

132 Main Street
P.O. Box 540
Palmyra, VA 22963
(434) 591-1910
Fax (434) 591-1911
www.fluvannacounty.org

IFB 2018-01	INVITATION TO BID: FARM HERITAGE MUSEUM BARN	BID OPENING: October 23, 2017 AT 2:00 p.m.
NOTICE TO ALL BIDDERS: All equipment and/or services provided under this invitation for Bid shall conform to the specifications and all terms and conditions as set forth.		

Have all Specifications included in this Invitation for Bid been met?
 Yes No

If no, please list all exceptions in detail on separate sheet.

Person to contact regarding this bid: _____

Title: _____ Phone: _____

Email Address: _____

Name of person authorized to bind the Firm: _____

Signature: _____ Date: _____

Name of Company: _____

Address: _____

By signing this bid, bidder certifies, acknowledges, understands and agrees to be bound by the conditions set forth in the contents of the bid including the General Terms and Conditions.

Work Description	Price
LUMP SUM COST FOR FARM HERITAGE MUSEUM BARN	

Optional Pricing (not required for this bid award)

Work Description	Price

Appendix I

COUNTY OF FLUVANNA

GENERAL TERMS, CONDITIONS AND INSTRUCTIONS TO BIDDERS AND CONTRACTORS

DRAFT

GENERAL TERMS, CONDITIONS AND INSTRUCTIONS TO BIDDERS AND CONTRACTORS

These General Terms, Conditions and Instructions to Bidders and Contractor (hereinafter referred to as the “General Conditions”) shall apply to all purchases and be incorporated into and be a part of each Solicitation (as defined below) and every Contract (as defined below) awarded by Fluvanna County, a political subdivision of the Commonwealth of Virginia (hereinafter referred to as the “County”) unless otherwise specified by the County in writing. Bidders, Offerors and Contractors or their authorized representatives are expected to inform themselves fully as to these General Conditions before submitting Bids or Proposals to and/or entering into any Contract with the County: failure to do so will be at the Bidder’s/Contractor’s own risk and except as provided by law, relief cannot be secured on the plea of error.

Subject to all Federal, State and local laws, policies, resolutions, regulations, rules, limitations and legislation, including the County’s Procurement Policies and Procedures, Bids or Proposals on all Solicitations issued by County will bind Bidders or Offerors, as applicable, and Contracts will bind Contractors, to all applicable terms, conditions, instructions, rules and requirements herein set forth unless otherwise SPECIFICALLY set forth by the County in writing in the Solicitation or Contract. All provisions of these General Conditions are material to any contract between the County and a Contractor.

INTRODUCTION

1. **VIRGINIA PUBLIC PROCUREMENT ACT AND ETHICS IN PUBLIC CONTRACTING:** The Virginia Public Procurement Act of Virginia Code §§ 2.2-4300 *et seq.* (hereinafter the “VPPA”) is incorporated herein by reference. Nothing in these General Conditions is intended to conflict with the VPPA and in case of any conflict, the VPPA controls. Specifically, the provisions of Article 6 of the VPPA (Virginia Code §§ 2.2-4367 through 2.2-4377) relating to ethics in contracting, shall be applicable to all Solicitations and Contracts solicited or entered into by the County. By submitting their Bids or signing any Contract, all Bidders and Contractors certify that they have not violated any of the provisions of Article 6 of the VPPA, including, but not limited to, that their Bids are made without collusion or fraud and that they have not offered or received any kickbacks or inducements.
2. **DEFINITIONS:** The definitions of Virginia Code §§ 2.2-4301, 2.2-4302.1 and 2.2-4302.2 are specifically incorporated herein by reference and as used in these General Conditions, whether capitalized or not, any of such defined terms have the same meaning as such terms have under the VPPA: such defined terms include: “Affiliate”, “Best Value”, “Business”, “Competitive Negotiation”, “Competitive Sealed Bidding”, “Construction”, “Construction Management Contract”, “Design-Build Contract”, “Employment Services Organization”, “Goods”, “Informality”, “Job Order Contracting”, “Multiphase Professional Services Contract”, “Nonprofessional Services”, “Potential Bidder or Offeror”, “Professional Services”, “Public Body”, “Public Contract”, “Responsible Bidder or Offeror”, “Responsive Bidder”, “Reverse Auctioning” and

“Services”. Additionally, as used in these General Conditions, the following terms, whether capitalized or not, have the following meanings:

- a. Bid/Proposal: The offer of a Bidder or Offeror to provide specific Goods or Services at specified prices and/or other conditions specified in the Solicitation. The term “Bid” is used throughout these General Conditions and where appropriate includes the term “Proposal” or any modifications or amendments to any Bid or Proposal.
- b. Bidder/Offeror/Vendor: Any individual(s), company, firm, corporation, partnership or other organization bidding or offering on any Solicitation issued by the County and/or offering to enter into Contracts with the County. The term “Bidder” is used throughout these General Conditions and where appropriate includes the term “Offeror” and/or “Vendor”.
- c. Contract: Any contract to which the County will be a party.
- d. Contractor: Any individual(s), company, firm, corporation, partnership, or other organization to whom an award is made by the County or whom enters into any contract to which the County is a party.
- e. County: The County of Fluvanna, a political subdivision of the Commonwealth of Virginia, including where applicable all agencies and departments of the County.
- f. County Administrator: The Fluvanna County Administrator.
- g. County Attorney: The Fluvanna County Attorney.
- h. Purchasing Agent: The County Administrator is the County’s Purchasing Agent and is responsible for the purchasing activity of Fluvanna County; and has signatory authority to bind the County to all contracts and purchases made lawfully under the Fluvanna County Small Purchasing Procedures. The Purchasing Agent has signatory authority to bind the County to all other contracts and purchases only after the contracts or purchases have been approved by a vote of the Fluvanna County Board of Supervisors.
- i. General Terms, Conditions and Instructions to Bidders and Contractors (also referred to herein as the “General Conditions”): These General Terms, Conditions and Instructions to Bidders and Contractors shall be attached to and made a part of all Solicitations by the County and all Contracts to which the County is party.
- j. His: Any references to “his” shall include his, her, their, or its as appropriate.
- k. Invitation to Bid (also referred to herein as an “IFB”): A request which is made to prospective Bidders for their quotation on Goods or Services desired by the County. The issuance of an IFB will contain or incorporate by reference the General Conditions and the other specifications and contractual terms and

conditions applicable to the procurement.

- l. Purchasing Officer: The Purchasing Officer employed by the County and to whom Bidders/Contractors can submit questions relating to any Bid or Contract.
 - m. Request for Proposal (also referred to herein as a “RFP”): A request for an offer from prospective Offerors which shall indicate the general terms which are sought to be procured from Offerors. The RFP will specify the evaluation factors to be used and will contain or incorporate by reference the General Conditions and other applicable contractual terms and conditions, including any unique capabilities or qualifications that will be required of the Contractor.
 - n. Small Purchasing Procedures: The County’s Small Purchasing Procedures, being Chapter 4 of the County’s Procurement Policies and Procedures, a method of purchasing not requiring competitive sealed bids or competitive negotiation for single or term contracts for goods and services other than professional services if the aggregate or the sum of all phases is not expected to exceed \$50,000; and also allowing for single or term contracts for professional services without requiring competitive negotiation, provided the aggregate or the sum of all phases is not expected to exceed \$50,000.
 - o. Solicitation: The process of notifying prospective Bidders or Offerors that the County wishes to receive Bids or Proposals on a set of requirements to provide Goods or Services. “Solicitation” includes any notification of the County requirements may consist of public advertising (newspaper, County’s website, or other electronic notification), the mailing of notices of Solicitation, any Invitation for Quotes (“IFQ”), Initiations to Bid (“IFB”), or Requests for Proposal (“RFP”), the public posting of notices, issuance of an Open Market Procurement (“OMP”), or telephone calls to prospective Bidders or Offerors.
 - p. State: The Commonwealth of Virginia.
3. **AUTHORITY**: The Purchasing Agent shall serve as the principal public purchasing official for the County, and shall be responsible for the procurement of goods, services, insurance and construction in accordance with the County’s Procurement Policies and Procedures. The Purchasing Agent has responsibility and authority for negotiating, placing and when necessary modifying every Solicitation, Contract and purchase order issued by the County under the County’s Small Purchasing Procedures. The Purchasing Agent has signatory authority to bind the County to all contracts and purchases made lawfully under the County’s Small Purchasing Procedures. The Purchasing Agent has responsibility and authority for negotiating, placing and when necessary modifying every other Solicitation, Contract and purchase order issued by the County except that the Purchasing Agent has signatory authority to bind the County to all other contracts and purchases ONLY after the contracts or purchases have been adopted and approved by a vote of the Fluvanna County Board of Supervisors (the “Board”).

Unless specifically delegated by the Board or the Purchasing Agent, and consistent with the limited authority granted thereto, no other County officer or employee is authorized to order supplies or Services, enter into purchase negotiations or Contracts, or in any way obligate the County for any indebtedness. Any purchase or contract made which is contrary to such authority shall be of no effect and void and the County shall not be bound thereby.

For convenience, the County's Purchasing Officer shall serve as an intermediary between the Purchasing Agent and the Bidder or Contractor and any Bidder or Contractor may direct communications regarding any purchase, Solicitation or Contract to the Purchasing Officer; however as stated *supra* only the Board or County's Purchasing Agent can bind the County and only upon the conditions stated *supra*.

CONDITIONS OF BIDDING

- 4. COMPETITION INTENDED:** It is the County's intent to encourage and permit open and competitive bidding in all Solicitations. It shall be the Bidder's responsibility to advise the County in writing if any language, requirement, specification, etc., or any combination thereof, stifles competition or inadvertently restricts or limits the requirements stated in a Solicitation to a single source. The County must receive such notification not later than seven (7) business days prior to the deadline set for acceptance of the Bids. In submitting a Bid, the Bidder guarantees that he or she has not been a party with other Bidders to an agreement to bid a fixed or uniform price. Violation of this implied guarantee shall render the Bid of any Bidder involved void.
- 5. DISCRIMINATION PROHIBITED:** Pursuant to Virginia Code § 2.2-4310, the County does not discriminate against Bidders, Offerors or Contractors because of race, religion, color, sex, national origin, age, disability, status as a service disabled veteran, or any other basis prohibited by state law relating to discrimination in employment. Whenever solicitations are made, the County shall include businesses selected from a list made available by the Department of Small Business and Supplier Diversity. Pursuant to Virginia Code § 2.2-4343.1, the County does not discriminate against "faith-based organizations", being a religious organization that is or applies to be a contractor to provide goods or services for programs funded by the block grant provided pursuant to the Personal Responsibility and Work Reconciliation Act of 1996, P.L. 104-193.
- 6. CLARIFICATION OF TERMS:** Pursuant to Virginia Code § 2.2-4316, if any Bidder has questions or comments about the specifications or other Solicitation documents, the prospective Bidder should contact the County no later than seven (7) business days prior to the date set for the opening of Bids or receipt of Proposals. Any revisions to the Solicitation will be made only by written addendum issued by the County. Notifications regarding specifications may not be considered if received in less than seven (7) business days of the date set for opening of Bids/receipt of Proposals.
- 7. MANDATORY USE OF COUNTY FORM AND TERMS AND CONDITIONS:** Unless otherwise specified in the Solicitation, all Bids must be submitted on the forms

provided by the County, including but not limited to, a Cover Sheet or Pricing Schedule, if applicable, properly signed in ink in the proper spaces and submitted in a sealed envelope or package. Unauthorized modification of or additions to any portion of the Solicitation may be cause for rejection of the Bid. However, the County reserves the right to decide, on a case by case basis, in its sole discretion, whether to reject any Bid or Proposal which has been modified. These General Conditions are mandatory provisions of all Solicitations and all Contracts of the County.

8. LATE BIDS & MODIFICATION OF BIDS: Any Bid or modification thereto received at the office designated in the Solicitation after the exact time specified for receipt of the Bid is considered a late Bid or modification thereof. The County is not responsible for delays in the delivery of the mail by the U.S. Postal Service, private carriers or the inter-office mail system. It is the sole responsibility of the Bidder to ensure their Bid reaches County by the designated date and hour. The following rules apply to all Bids submitted to the County:

- a. The official time used in the receipt of Bids/Proposals is that time on the automatic time stamp machine in the Finance Department;
- b. Late Bids or modifications thereof will be returned to the Bidder UNOPENED, if Solicitation number, due date and Bidder's return address is shown on the container;
- c. If a Bid is submitted on time, however a modification thereto is submitted after the due date and time, then the County in its sole discretion may choose to consider the original Bid except that the County may not consider such original Bid if the Bid is withdrawn by the Bidder pursuant to Section 9 below; and
- d. If an emergency or unanticipated event or closing interrupts or suspends the County's normal business operations so that Bids cannot be received by the exact time specified in the Solicitation, then the due date/time specified for receipt of Bids will be deemed to be extended to the same time of day specified in the Solicitation on the first work day on which normal County business operations resume.

9. WITHDRAWAL OF BIDS:

- a. Pursuant to Virginia Code § 2.2-4330, a Bidder for a public construction contract, other than a contract for construction or maintenance of public highways, may withdraw his Bid from consideration if the price bid was substantially lower than the other Bids due solely to a mistake in the Bid, provided the Bid was submitted in good faith, and the mistake was a clerical mistake as opposed to a judgment mistake, and was actually due to an unintentional arithmetic error or an unintentional omission of a quantity of work, labor or material made directly in the compilation of a Bid, which unintentional arithmetic error or unintentional omission can be clearly shown by objective evidence drawn from inspection of original work papers, documents and materials used in the preparation of the Bid sought to be withdrawn.

If a Bid contains both clerical and judgment mistakes, a Bidder may withdraw his Bid from consideration if the price bid would have been substantially lower than the other Bids due solely to the clerical mistake, that was an unintentional arithmetic error or an unintentional omission of a quantity of work, labor or material made directly in the compilation of a Bid that shall be clearly shown by objective evidence drawn from inspection of original work papers, documents and materials used in the preparation of the Bid sought to be withdrawn. The Bidder shall give notice in writing to the County of his or her claim of right to withdraw his or her Bid within two (2) business days after the conclusion of the Bid opening procedure and shall submit original work papers with such notice.

- b. A Bidder for a Contract other than for public construction may request withdrawal of his or her Bid under the following circumstances:
 - i. Bids may be withdrawn on written request from the Bidder received at the address shown in the Solicitation prior to the time of opening.
 - ii. Requests for withdrawal of Bids after opening of such Bids but prior to award shall be transmitted to the County, in writing, accompanied by full documentation supporting the request. If the request is based on a claim of error, documentation must show the basis of the error. Such documentation may take the form of supplier quotations, Bidder work sheets, etc. If Bid bonds were tendered with the Bid, the County may exercise its right of collection.
- c. No Bid may be withdrawn under this Section 9 when the result would be the awarding of the Contract on another Bid of the same Bidder or of another Bidder in which the ownership of the withdrawing Bidder is more than five percent (5%).
- d. If a Bid is withdrawn under the authority of this Section 9 the lowest remaining Bid shall be deemed to be the low Bid.
- e. No Bidder who, is permitted to withdraw a Bid shall, for compensation, supply any material or labor to or perform any subcontract or other work agreement for the person or firm to whom the Contract is awarded or otherwise benefit, directly or indirectly, from the performance of the project for which the withdrawn Bid was submitted.
- f. The County shall notify the Bidder in writing within five (5) business days of its decision regarding the Bidder's request to withdraw its Bid. If the County denies the withdrawal of a Bid under the provisions of this Section 9, it shall State in such notice the reasons for its decision and award the Contract to such Bidder at the Bid price, provided such Bidder is a responsible and responsive Bidder. At the same time that the notice is provided, the County shall return all work papers and copies thereof that have been submitted by the Bidder.

- g. Under these procedures, a mistake shall be proved only from the original work papers, documents and materials delivered as required herein. The work papers, documents and materials submitted by the bidder shall, at the bidder's request, be considered trade secrets or proprietary information subject to the conditions of subsection F of Virginia Code § 2.2-4342.

10. ERRORS IN BIDS: When an error is made in extending total prices, the unit Bid price will govern. Erasures in Bids must be initialed by the Bidder. Carelessness in quoting prices, or otherwise in preparation of the Bid, will not relieve the Bidder. Bidders/Offerors are cautioned to recheck their Bids for possible error. Errors discovered after public opening cannot be corrected and the Bidder will be required to perform if his or her Bid is accepted.

11. IDENTIFICATION ON BID ENVELOPE: All Bids, Proposals and requested copies thereof submitted to the County shall be in a separate envelope or package, sealed and identified with the following information clearly marked on the outside of the envelope or package:

- a. Addressed as indicated on page 1 of the solicitation;
- b. Solicitation number;
- c. Title;
- d. Bid due date and time;
- e. Bidder's name and complete mailing address (return address); and
- f. Pursuant to Virginia Code § 2.2-4311.2, the Bidder's identification number issued by the State Corporation Commission, or if the bidder is not required to be authorized to transact business in the Commonwealth as a foreign business entity under Title 13.1 or Title 50 or as otherwise required by law shall include in its bids or proposal a statement describing why the bidder or offeror is not required to be so authorized.

If a Bid is not addressed with the information as shown above, the Bidder takes the risk that the envelope may be inadvertently opened and the information compromised, which may cause the Bid to be disqualified. Bids may be hand delivered to the designated location in the County's offices. No other correspondence or other Proposals/Bids should be placed in the envelope. Any Bidder or Offeror that fails to provide the information required in (f) above shall not receive an award unless a waiver is specifically granted by the County Administrator.

12. ACCEPTANCE OF BIDS: Unless otherwise specified, all formal Bids or Proposals submitted shall be valid for a minimum period of one hundred twenty (120) calendar days following the date established for opening or receipt, respectively, unless extend by mutual agreement of the parties. At the end of the one hundred twenty (120) calendar days the Bid/Proposal may be withdrawn at the written request of the Bidder. Thereafter, unless and until the Proposal is withdrawn, it remains in effect until an award is made or the Solicitation is canceled by the County. The County may cancel any Solicitation at any time by notice of such cancelation to the Bidders.

- 13. COMPLETENESS:** To be responsive, a Bid must include all information required by the Solicitation.
- 14. CONDITIONAL BIDS:** Conditional Bids are subject to rejection in whole or in part.
- 15. RESPONSE TO SOLICITATIONS:** In the event a Bidder cannot submit a Bid on a Solicitation, the Bidder is requested to return the Solicitation cover sheet with an explanation as to why the Bidder is unable to Bid on these requirements, or if there be no cover sheet for the Solicitation a letter to the County explaining the same.
- 16. BIDDER INTERESTED IN MORE THAN ONE BID AND COLLUSION:** More than one bid from an individual, firm, partnership, corporation or association under the same or different name will be rejected. Reasonable grounds for believing that a bidder is interested in more than one bid for the work contemplated will cause rejection of all bids in which the bidder is interested. Any or all bids may be rejected if there is any reason for believing that collusion exists among the bidders. Participants in such collusion may not be considered in future bids for the same work. Each bidder, as a condition of submitting a bid, shall certify that he is not a party to any collusive action as herein defined. However, a party who has quoted prices on work, materials, or supplies to a Bidder is not thereby disqualified from quoting prices to other Bidders or firms submitting a Bid directly for the work, materials or supplies.
- 17. BID OPENING:** Pursuant to Virginia Code § 2.2-4301, all Bids received in response to an IFB will be opened at the date, time and place specified, and announced publicly, and made available for inspection as provided in Section 21 of these General Conditions. Proposals received in response to an RFP will be made available for inspection as provided in Section 21 of these General Conditions.
- 18. TAX EXEMPTION:** The County is exempt from the payment of any federal excise or any Virginia sales tax. The price bid must be net, exclusive of taxes. Tax exemption certificates will be furnished if requested by the Bidder.
- 19. DEBARMENT STATUS:** By submitting their Bids, Bidders certify that they are not currently debarred from submitting Bids on Contracts by the County, nor are they an agent of any person or entity that is currently debarred from submitting Bids or Proposals on Contracts by the County or any agency, public entity/locality or authority of the State.
- 20. NO CONTACT POLICY:** No Bidder shall initiate or otherwise have contact related to the Solicitation with any County representative or employee, other than the Purchasing Officer or Purchasing Agent, after the date and time established for receipt of Bids. Any contact initiated by a Bidder with any County representative, other than the Purchasing Officer or Purchasing Agent, concerning this Solicitation is prohibited and may cause the disqualification of the Bidder.

21. VIRGINIA FREEDOM OF INFORMATION ACT: As provided under Virginia Code § 2.2-4342, all proceedings, records, Contracts and other public records relating to procurement transactions shall be open to the inspection of any citizen, or any interested person, firm or corporation, in accordance with the Virginia Freedom of Information Act of Virginia Code §§ 2.2-3700 *et seq.*, except:

- a. Cost estimates relating to a proposed procurement transaction prepared by or for the County shall not be open to public inspection;
- b. Any competitive sealed bidding Bidder, upon request, shall be afforded the opportunity to inspect Bid records within a reasonable time after the opening of Bids but prior to award, except in the event that the County decides not to accept any of the Bids and to reopen the Contract. Otherwise, Bid records shall be open to public inspection only after award of the Contract;
- c. Any competitive negotiation Offeror, upon request, shall be afforded the opportunity to inspect Proposal records within a reasonable time after the evaluation and negotiations of Proposals are completed but prior to award except in the event that the County decides not to accept any of the Proposals and to reopen the Contract. Otherwise, Proposal records shall be open to the public inspection only after award of the Contract;
- d. Any inspection of procurement transaction records under this Section 21 shall be subject to reasonable restrictions to ensure the security and integrity of the records;
- e. Trade secrets or proprietary information submitted by a Bidder, Offeror or Contractor in connection with a procurement transaction shall not be subject to public disclosure under the Virginia Freedom of Information Act; however, the Bidder, Offeror or Contractor must invoke the protections of this Section 21 prior to or upon submission of the data or other materials, and must identify the data or other materials to be protected and State the reasons why protection is necessary; and
- f. Nothing contained in this Section 21 shall be construed to require the County, when procuring by “competitive negotiation” (RFP), to furnish a Statement of reasons why a particular Proposal was not deemed to be the most advantageous to the County.

22. CONFLICT OF INTEREST: Bidder/Contractor certifies by signing any Bid/Contract to/with the County that no conflict of interest exists between Bidder/Contractor and County that interferes with fair competition and no conflict of interest exists between Bidder/Contractor and any other person or organization that constitutes a conflict of interest with respect to the Bid/Contract with the County.

SPECIFICATIONS

23. OMISSIONS OR DISCREPANCIES: Any items or parts of any equipment listed in a Solicitation which are not fully described or are omitted from such specification, and which are clearly necessary for the completion of such equipment and its appurtenances, shall be considered a part of such equipment although not directly specified or called for

in the specifications. Should a Bidder find a discrepancy or ambiguity in, or an omission from, the Solicitation, including the drawings and/or specifications, he or she shall so notify the County within twenty-four (24) hours of noting the discrepancy, ambiguity or omission and in any event no less than five (5) days prior to the date set for the opening of Bids. If necessary, the County will send a written addendum for clarification to all Bidders no later than three (3) days before the date set for opening of Bids. Any notification regarding specifications received less than five (5) days prior to the date set for the opening of Bids may or may not be considered by the County in its sole discretion. The Bidder shall abide by and comply with the true intent of the specifications and not take advantage of any unintentional error or omission, but shall fully complete every part as the true intent and meaning of the specifications and drawings. Whenever the mention is made of any articles, material or workmanship to be in accordance with laws, ordinances, building codes, underwriter's codes, A.S.T.M. regulations or similar expressions, the requirements of these laws, ordinances, etc., shall be construed as to the minimum requirements of these specifications.

- 24. BRAND NAME OR EQUAL ITEMS:** Pursuant to Virginia Code § 2.2-4315, unless otherwise provided in the Solicitation, the name of a certain brand, make or manufacturer does not restrict Bidders to the specific brand, make or manufacturer named; it conveys the general style, type, character, and quality of the article desired, and any article which the County in its sole discretion determines to be the equal of that specified, considering quality, workmanship, economy of operation, and suitability for the purpose intended, shall be accepted. The Bidder is responsible to clearly and specifically indicate the product being offered and to provide sufficient descriptive literature, catalog cuts and technical detail to enable the County to determine if the product offered meets the requirements of the Solicitation. This is required even if offering the exact brand, make or manufacturer specified. Normally in competitive sealed bidding, only the information furnished with the Bid will be considered in the evaluation. Failure to furnish adequate data for evaluation purposes may result in declaring a Bid non-responsive. Unless the Bidder clearly indicates in its Bid that the product offered is "equal" product, such Bid will be considered to offer the brand name product referenced in the Solicitation.
- 25. FORMAL SPECIFICATIONS:** When a Solicitation contains a specification which states no substitutes, no deviation therefrom will be permitted and the Bidder will be required to furnish articles in conformity with that specification.
- 26. CONDITION OF ITEMS:** Unless otherwise specified in the Solicitation, all items shall be new, in first class condition.

AWARD

- 27. RESPONSIBLE BIDDERS:** In determining whether a Bidder is a responsible Bidder as defined herein, at minimum, the following criteria will be considered:
- a. The ability, capacity and skill of the Bidder to perform the Contract or provide the service required under the Solicitation;

- b. Whether the Bidder can perform the Contract or provide the service promptly, or within the time specified, without delay or interference;
- c. The character, integrity, reputation, judgment, experience and efficiency of the Bidder;
- d. The quality of performance of previous Contracts or Services;
- e. The previous and existing compliance by the Bidder with laws and ordinances relating to the Contract or Services;
- f. The sufficiency of the financial resources and ability of the Bidder to perform the Contract or provide the service;
- g. The quality, availability and adaptability of the Goods or Services to the particular use required;
- h. The ability of the Bidder to provide future maintenance and service for the use of the subject of the Contract;
- i. The number and scope of the conditions attached to the Bid;
- j. Whether the Bidder is in arrears to the County on debt or Contract or is a defaulter on surety to the County or whether the Bidder's County taxes or assessments are delinquent; and
- k. Such other information as may be secured by the County, the Purchasing Agent or the Purchasing Officer having a bearing on the decision to award the Contract. If an apparent low Bidder is not awarded a Contract for reasons of nonresponsibility, the County shall so notify that Bidder and shall have recorded the reasons in the Solicitation or Contract file.

28. AWARD OR REJECTION OF BIDS; WAIVER OF INFORMALITIES: The County shall award the Contract to the lowest responsive and responsible Bidder complying with all provisions of the IFB, provided the Bid price is reasonable and it is in the best interest of the County to accept it. Awards made in response to a RFP will be made to the highest qualified Offeror whose Proposal is determined, in writing, to be the most advantageous to the County taking into consideration the evaluation factors set forth in the RFP. The County reserves the right to award a Contract by individual items, in the aggregate, or in combination thereof, or to reject any or all Bids and to waive any informality in Bids received whenever such rejection or waiver is in the best interest of the County. Award may be made to as many Bidders/Offerors as deemed necessary to fulfill the anticipated requirements of the County. The County also reserves the right to reject the Bid if a Bidder is deemed to be a non-responsible Bidder. Pursuant to Virginia Code § 2.2-4319, an IFB, a RFP, any other solicitation, or any and all bids or proposals, may be canceled or rejected by the County at any time. The reasons for cancellation or rejection shall be made part of the contract file. The County shall not cancel or reject an IFB, a RFP, any other solicitation, bid or proposal solely to avoid awarding a contract to a particular responsive and responsible bidder or offeror.

29. EXCLUSION OF INSURANCE BIDS PROHIBITED: Pursuant to Virginia Code § 2.2-4320, notwithstanding any other provision of law or these General Conditions, no insurer licensed to transact the business of insurance in the State or approved to issue surplus lines insurance in the State shall be excluded from presenting an insurance bid proposal to the County in response to a RFP or an IFB; excepting that the County may

debar a prospective insurer pursuant to its Debarment Policy, see Chapter 2 of the County's Procurement Policies and Procedures.

30. ANNOUNCEMENT OF AWARD: Upon the award or announcement of the decision to award a Contract as a result of this Solicitation, the County will publicly post such notice on the County's bulletin board located at 72 Main Street, 2nd Floor, Palmyra, Virginia 22963. Award results may also be viewed on the County's website.

31. QUALIFICATIONS OF BIDDERS OR OFFERORS: The County may make such reasonable investigations as deemed proper and necessary to determine the ability of the Bidder to perform the work/furnish the item(s) and the Bidder shall furnish to the County all such information and data for this purpose as may be requested. The County reserves the right to inspect Bidder's physical facilities prior to award to satisfy questions regarding the Bidder's capabilities. The County further reserves the right to reject any Bid or Proposal if the evidence submitted by or investigations of, such Bidder fails to satisfy the County that such Bidder is properly qualified to carry out the obligations of the Contract and to complete the work/furnish the item(s) contemplated therein.

32. TIE BIDS AND PREFERENCE FOR VIRGINIA PRODUCTS WITH RECYCLED CONTENT AND FOR VIRGINIA FIRMS:

- a. Pursuant to Virginia Code § 2.2-4328, in the case of a tie bid on an IFB only, the County may give preference to Goods, Services and construction produced in Fluvanna County or provided by persons, firms or corporations having principal places of business in Fluvanna County. If such choice is not available, preference shall then be given to Goods produced in Virginia, or for goods, services or construction provided by Virginia persons, firms, corporations, pursuant Virginia Code § 2.2-4324. If no County or State choice is available, the tie shall be decided publicly by lot. The decision by the County to make award to one or more such Bidders shall be final.
- b. Whenever the lowest responsive and responsible bidder is a resident of any other state and such state under its laws allows a resident contractor of that state a percentage preference, a like preference shall be allowed to the lowest responsive and responsible bidder who is a resident of Virginia and is the next lowest bidder. If the lowest responsive and responsible bidder is a resident of any other state and such state under its laws allows a resident contractor of that state a price-matching preference, a like preference shall be allowed to responsive and responsible bidders who are residents of Virginia. If the lowest bidder is a resident contractor of a state with an absolute preference, the bid shall not be considered. The Department of General Services shall post and maintain an updated list on its website of all states with an absolute preference for their resident contractors and those states that allow their resident contractors a percentage preference, including the respective percentage amounts. For purposes of compliance with this Section 32, the County may rely upon the accuracy of the information posted on this website.
- c. Notwithstanding the provisions of subsections a and b, in the case of a tie bid in instances where goods are being offered, and existing price preferences have

already been taken into account, preference shall be given to the bidder whose goods contain the greatest amount of recycled content.

- d. For the purposes of this Section 32, a Virginia person, firm or corporation shall be deemed to be a resident of Virginia if such person, firm or corporation has been organized pursuant to Virginia law or maintains a principal place of business within Virginia.

33. NEGOTIATION WITH LOWEST RESPONSIBLE BIDDER: Pursuant to Virginia Code § 2.2-4318, unless cancelled or rejected, a responsive Bid from the lowest responsible Bidder shall be accepted as submitted, except that if the Bid from the lowest responsible Bidder exceeds available funds, the County may negotiate with the apparent low Bidder to obtain a Contract price within available funds. However, the negotiation may be undertaken only under conditions and procedures described in writing and approved by the County prior to issuance of the IFB and summarized therein.

CONTRACT PROVISIONS

34. APPLICABLE LAW AND COURTS: Any Bid or Contract resulting from a Solicitation and its terms, including, but not limited to, the parties' obligations under it, and the remedies available to each party for breach of it, shall be governed by, construed and interpreted in accordance with the laws of the Commonwealth of Virginia, and exclusive jurisdiction and venue of any dispute or matters involving litigation between the parties hereto shall be in the courts of Fluvanna County, Virginia. Any jurisdiction's choice of law, conflict of laws, rules, or provisions, including those of the Commonwealth of Virginia, that would cause the application of any laws other than those of the Commonwealth of Virginia, shall not apply. The Contractor shall comply with applicable federal, State and local laws, ordinances, rules and regulations in performance of the Contract.

35. PROVISION AND OWNERSHIP OF INFORMATION: The County shall make a good faith effort to identify and make available to the Contractor all non-confidential technical and administrative data in the County's possession which the County may lawfully release including, but not limited to Contract specifications, drawings, correspondence, and other information specified and required by the Contractor and relating to its work under any Contract. The County reserves its rights of ownership to all material given to the Contractor by the County and to all background information documents, and computer software and documentation developed by the Contractor in performing any Contract.

36. DOCUMENTS: All documents, including but not limited to data compilations, drawings, reports and other material, whether in hard copy or electronic format, prepared, developed or furnished by the Contractor pursuant to any Contract shall be the sole property of the County. At the direction of the County, the Contractor shall have the right to make copies of the documents produced available to other parties. The County shall be entitled to delivery of possession of all documents, upon payment in accordance with the terms of any Contract for the service incurred to produce such documents.

37. CONFIDENTIALITY: Contractor shall not publish, copyright or otherwise disclose or permit to be disclosed or published, the results of any work performed pursuant to this contract, or any particulars thereof, including forms or other materials developed for the County in connection with the performance by Contractor of its services hereunder, without prior written approval of the County. Contractor, cognizant of the sensitive nature of much of the data supplied by the County, shall not disclose any information (other than information which is readily available from sources available to the general public) obtained by it in the course of providing services hereunder without the prior written approval of the County, unless disclosure of such information by it is required by law, rule or regulation or the valid order of a court or administrative agency.

38. INDEPENDENT CONTRACTOR: The Contractor and any agents, or employees of the Contractor, in the performance of any Contract shall act as an independent contractor and not as officers, employees or agents of the County.

39. INSURANCE: The Contractor agrees that, during the period of time it renders services to the County pursuant to any Contract, it shall carry (and provide the County with evidence of coverage) the following minimum amounts of insurance:

Automobile	\$500,000	Liability Medical Payment Comprehensive Collision
Public Liability	\$1,000,000	
Professional Liability	\$1,000,000	
Excess Liability	\$2,000,000	Aggregate Over Above Policy Limits (Excluding Professional Liability)
Worker's Compensation	Amount required by Virginia law	

The Contract may specifically require the Contractor to carry higher minimum amounts of insurance.

In addition, the Contractor shall require, and shall include in every subcontract, that any subcontractor providing any goods or services related to such Contract obtain, and continue to maintain for the duration of the work, workers' compensation coverage in the amount required by Virginia law.

40. KEY PERSONNEL: For the duration of any Contract, the Contractor shall make no substitutions of key personnel unless the substitution is necessitated by illness, death, or termination of employment, or as expressly approved by the County. The Contractor

shall notify the County within five (5) calendar days after the occurrence of any of these events and provide the information required by the paragraph below.

The Contractor shall provide a detailed explanation of the circumstances necessitating any proposed substitution, complete resumes for the proposed substitute, and any additional information requested by the County. The proposed substitute should have comparable qualifications to those of the person being replaced. The County will notify the Contractor within fifteen (15) calendar days after receipt of all required information of its approval or disapproval of the proposed substitution.

- 41. SEVERABILITY:** If any term, covenant or provision of these General Conditions or any Contract shall be held to be invalid, illegal or unenforceable in any respect, these General Conditions and any Contract shall remain in effect and be construed without regard to such provision.
- 42. TITLES:** The titles and section headings herein and in any Contract are inserted solely for convenience and are not to be construed as a limitation on the scope of the provisions to which they refer.
- 43. ATTORNEYS' FEES:** In the event of a dispute between the County and Contractor under any Contract which cannot be amicably resolved, in addition to all other remedies, the party substantially prevailing in any litigation shall be entitled to recover its reasonable expenses, including, but not limited to, reasonable attorneys' fees.
- 44. NO WAIVER:** Neither any payment for, nor acceptance of, the whole or any part of the services by the County, nor any extension of time, shall operate as a waiver of any provision of any Contract, nor of any power herein reserved to the County, or any right to damages herein provided, nor shall any waiver of any breach of any Contract be held to be a waiver of any other or subsequent breach. Failure of the County to require compliance with any term or condition of any Contract shall not be deemed a waiver of such term or condition or a waiver of the subsequent enforcement thereof.
- 45. NO FINANCE CHARGES:** No finance charges shall be paid by the County.
- 46. ANTITRUST:** By entering into a Contract, the Contractor conveys, sells, assigns, and transfers to the County all rights, title and interest in and to all causes of the action it may now have or hereafter acquire under the antitrust law of the United States or the State, relating to the particular Goods or Services purchased or acquired by the County under said Contract. Consistent and continued tie bidding could cause rejection of Bids by the County and/or investigation for antitrust violations.
- 47. PAYMENT:** Pursuant to Virginia Code § 2.2-4352, unless more time is provided in the Solicitation or Contract, payment will be made forty-five (45) days after receipt by the County of a proper invoice, or forty-five (45) days after receipt of all Goods or acceptance of work, whichever is later. The County reserves the right to withhold any or all payments or portions thereof for Contractor's failure to perform in accordance with the

provision of the Contract or any modifications thereto. Within twenty (20) days of receipt of proper invoice or of goods or services, the County shall notify the Contractor if any defect or impropriety that would prevent payment by the payment date. The following provisions apply to such payments:

- a. Invoices for items/Services ordered, delivered/performed and accepted shall be submitted by the Contractor in duplicate directly to the payment address shown on the purchase order, Solicitation or Contract, as applicable. All invoices shall show the Contract number, purchase order number, or Solicitation number, as applicable, and as required under Virginia Code § 2.2-4354, either the individual Contractor's social security number or the Contractor's federal employer identification number, whichever is applicable.
- b. Any payment terms requiring payment in less than forty-five (45) days will be regarded as requiring payment forty-five (45) days after receipt of proper invoice or receipt of all Goods or acceptance of work, whichever occurs later. Notwithstanding the foregoing, offers of discounts for payment in less than forty-five (45) days are valid and enforceable.
- c. Pursuant to Virginia Code § 2.2-4353, the date any payment shall be deemed the date of postmark in all cases where payment is made by mail.
- d. The County's fiscal year is July 1 to June 30. Contractors are advised to submit invoices, especially for Goods and/or Services provided in the month of June, for the entire month (i.e. June 1 - June 30), so that expenses are recognized in the appropriate fiscal year.
- e. Any payment made by the Contractor to the County shall only be made in U.S. Dollars. If payment is received in foreign currency the County may, in its sole discretion, reject such payment and require immediate compensation in U.S. Dollars.

48. SUBCONTRACTORS: Pursuant to Virginia Code § 2.2-4354, in the event that any subcontractors are used by Contractor in connection with the work, Contractor shall:

- a. Within seven (7) days after receipt of amounts paid to the Contractor for work performed by a subcontractor, either:
 - i. Pay the subcontractor for the proportionate share of the total payment received attributable to the work performed by the subcontractor under any Contract; or
 - ii. Notify the County and subcontractor, in writing, of his intention to withhold all or a part of the subcontractor's payment with the reason for nonpayment.

- b. Contractor shall require each subcontractor to provide either (i) for an individual, their social security numbers, or (ii) for proprietorships, partnerships, and corporations to provide their federal employer identification numbers.
- c. The Contractor shall pay interest to any subcontractor on all amounts owed by the Contractor that remain unpaid after seven days following receipt by the Contractor of payment from the County for work performed by the subcontractor under any Contract, except for amounts withheld as allowed in subdivision (a)(II) above. Unless otherwise provided under the terms of any Contract, interest shall accrue at the rate of one percent (1%) per month.
- d. The Contractor shall include in each of its subcontracts under any Contract a provision requiring each subcontractor to include or otherwise be subject to the above payment and interest requirements (a), (b) and (c) with respect to each lower tier subcontractor.
- e. The Contractor's obligation to pay an interest charge to a subcontractor pursuant to the payment clause in this Section 48 shall not be construed to be an obligation of the County. No Contract modification may be made for the purpose of providing reimbursement for such interest charge. No cost reimbursement claim may include any amount for reimbursement for such interest charge.

49. RETAINAGE ON CONSTRUCTION CONTRACTS: Pursuant to Virginia Code 2§ 2.2-4333, if a Contract for construction provides for progress payments in installments based upon an estimated percentage of completion, then the contractor shall be paid at least ninety-five percent (95%) of the earned sum when payment is due, with no more than five percent (5%) being retained to ensure faithful performance of the contract. All amounts withheld may be included in the final payment. Any subcontract related to work on a Contract that provides for similar progress payments shall be subject to the provisions above and the Contractor agrees to include such provisions in every subcontract.

50. SUCCESSORS AND ASSIGNS: The County and the Contractor bind themselves and their respective successors and assigns to any Contract. The foregoing notwithstanding, the Contractor shall not assign, sublet or transfer its interest in any Contract without the prior written consent of the County, which may be granted or withheld in the County's sole discretion. Nothing hereinafter mentioned shall be construed as creating any personal liability on the part of any officer, agent or employee of the County, nor shall it be construed as giving any benefits hereunder to anyone other than the County and the Contractor.

51. DEFAULT: Failure of a Contractor to deliver Goods or Services in accordance with Contract terms and conditions and/or within the time specified, or within reasonable time as interpreted by the County in its sole discretion, or failure to make replacements/corrections of rejected articles/services when so requested, immediately or as directed by the County, or failure of the Contractor to act in accordance with the Contract in any material respect, as reasonably determined by the County, shall constitute

a “default” by the Contractor and shall further authority for the County to purchase in the open market articles/services of comparable grade/quality to replace the services, articles rejected, and/or not delivered. On all such purchases, the Contractor shall reimburse the County, within a reasonable time specified by the County, for any expense incurred in excess of Contract prices including, but not limited to, any purchase and administrative costs. Such purchases shall be deducted from the Contract quantities, if applicable. Should public necessity demand it, the County reserves the right to use or consume articles delivered or services performed which are substandard in quality, subject to an adjustment in price to be determined by the County. In case of any default, the County, after due oral or written notice if required in accordance with the Contract, may terminate the Contract at its option in its sole discretion effective immediately. These remedies shall be in addition to any other remedies which the County may have, including but not limited to, any remedies at law, under the Contract or in equity.

Notwithstanding the foregoing, the Contractor shall not be liable for damages for delay in shipment or failure to deliver when such delay or failure is the result of fire, flood, strike, act of God, act of Government, act of an alien enemy or by any other circumstances which, in the County's opinion, are beyond the control of the Contractor. Under such circumstances, however, the County may, at its sole discretion, terminate or cancel the Contract effective immediately.

52. NON-DISCRIMINATION ASSURANCES: The Contractor shall conform to the provisions of the Federal Civil Rights Act of 1964, as amended, as well as the Virginia Fair Employment Act of 1975, as amended, where applicable, and § 2.2-4311 of the Virginia Procurement Act:

- a. During the performance of any Contract, the Contractor agrees as follows: the Contractor will not discriminate against any employee or applicant for employment because of race, religion, color, sex, national origin, age, disability, or other basis prohibited by state law relating to discrimination in employment, except where there is a bona fide occupational qualification reasonably necessary to the normal operation of the Contractor. The Contractor agrees to post in conspicuous places, available to employees and applicants for employment, notices setting forth the provisions of this nondiscrimination clause. The Contractor, in all Solicitations or advertisements for employees placed by or on behalf of the Contractor, will state that such Contractor is an equal opportunity employer. Notices, advertisements and Solicitations placed in accordance with federal law, rule or regulation shall be deemed sufficient for the purpose of meeting the requirements of this Section 52.
- b. The Contractor shall include the provisions of paragraph (a) above in every subcontract or purchase over \$10,000.00 so that the provisions will be binding upon each subcontractor or Vendor.

53. MODIFICATION:

- a. Pursuant to Virginia Code § 2.2-4309, these General Conditions and any Contract entered into by the County and any Contractor shall not be subject to change, modification, or discharge except by written instrument signed by the County and Contractor, but no fixed-price contract may be increased by more than twenty-five percent (25%) of the amount of the contract or \$50,000, whichever is greater, without the advance written approval of the County's Board. In no event may the amount of any contract, without adequate consideration, be increased for any purpose, including, but not limited to, relief of an offeror from the consequences of an error in its bid or offer.
- b. The County may, but is not obligated to, extend the term of an existing contract for services to allow completion of any work undertaken but not completed during the original term of the contract.
- c. Nothing in this Section 53 shall prevent the County from placing greater restrictions on contract modifications.

54. INDEMNIFICATION: Contractor agrees to indemnify, keep and save harmless the County, its officers, agents, officials, employees and volunteers against any and all claims, claims of injuries, death, damage to property, patent claims, suits, liabilities, judgments, losses, costs and expenses, including but not limited to costs of investigation, all reasonable attorneys' fees (whether or not litigation results), and the cost of any appeal, occurring or arising in connection with the Contractor's, its agents', subcontractors', employees', or volunteers' negligence or wrongful acts or omissions in connection with its performance of any Contract. The Contractor shall, at his or her own expense, appear, defend and pay all charges of attorneys and all costs and other expenses arising therefrom or incurred in connection therewith; and if any judgment shall be rendered against the County in any such action, the Contractor shall, at his or her own expenses, satisfy and discharge the same. Contractor expressly understands and agrees that any performance bond or insurance protection required by any Contract, or otherwise provided by the Contractor, shall in no way limit the responsibility to indemnify, keep and save harmless and defend the County as herein provided. Nothing contained in this Solicitation or the Contract shall be deemed to be a waiver of the County's sovereign immunity.

55. DRUG-FREE WORKPLACE: Pursuant to Virginia Code § 2.2-4312, in every Contract over \$10,000.00 the following provisions apply: During the performance of any Contract, the Contractor agrees to (i) provide a drug-free workplace for the Contractor's employees; (ii) post in conspicuous places, available to employees and applicants for employment, a Statement notifying employees that the unlawful manufacture, sale, distribution, dispensation, possession, or use of a controlled substance or marijuana is prohibited in the Contractor's workplace and specifying the actions that will be taken against employees for violations of such prohibition; (iii) state in all Solicitations or advertisements for employees placed by or on behalf of the Contractor that the Contractor maintains a drug-free workplace; and (iv) include the provisions of the

foregoing clauses in every subcontract or purchase order of over \$10,000, so that the provisions will be binding upon each subcontractor or vendor.

For the purposes of this Section, “*drug-free workplace*” means a site for the performance of work done in connection with a specific Contract awarded to a Contractor in accordance with this the VPPA and the County’s Procurement Procedures, the employees of whom are prohibited from engaging in the unlawful manufacture, sale, distribution, dispensation, possession or use of any controlled substance or marijuana during the performance of the Contract.

56. TERMINATION: Contracts will remain in force for full periods specified and/or until all articles ordered before date of termination shall have been satisfactorily delivered and accepted and thereafter until all requirements and conditions shall have been met, unless:

- a. Terminated prior to expiration date by satisfactory deliveries of entire Contract requirements;
- b. Terminated by the County upon thirty (30) days written notice to the Contractor at the County’s convenience in the County’s sole discretion (“termination for convenience”), unless a termination for convenience is specifically and expressly prohibited by the Contract. Any Contract cancellation notice shall not relieve the Contractor of the obligation to deliver and/or perform on all outstanding orders issued prior to the effective date of the termination;
- c. Terminated by the County for cause, default or negligence on the part of the Contractor. However, pursuant to Section 51 of these General Conditions, the County may hold the Contractor responsible for any resulting additional purchase and administrative costs. There is no advance notice requirement in the event of Termination for Cause and termination is effective immediately upon notice to Contractor of the termination for cause;
- d. Extended upon written authorization of County and accepted by Contractor, to permit ordering of unordered balances or additional quantities at Contract prices and in accordance with Contract terms.

57. APPROPRIATIONS: Notwithstanding any other provision of any Contract, the payment of the County's obligations under any Contract shall be subject to annual appropriations by the Board of Supervisors of the County in each fiscal year of monies sufficient to satisfy the same.

58. REFERENCES TO VIRGINIA LAW: Any reference in these General Conditions to the Code of Virginia or other relevant Federal, State or local law is incorporated in whole herein by reference as in effect at the time of the Solicitation or Contract as such statutory provisions may be amended or replaced by any statute dealing with the same or similar subject matter.

- 59. COOPERATIVE PROCUREMENT:** Except as prohibited by the current Code of Virginia, all resultant Contracts will be extended to other Public Bodies of the Commonwealth of Virginia, to permit their ordering of Goods, supplies and/or Services at the prices and terms of the resulting Contract (“cooperative procurement”). By submitting any Bid or entering into any Contract with the County a Bidder/Contractor expressly authorizes cooperative procurement under Virginia Code § 2.2-4304 to the full extent permitted by law. If any other public body decides to use any Contract, the Contractor must deal directly with that public body concerning all matters relating thereto, including but not limited to, the placement or orders, issuance of the purchase order, contractual disputes, invoicing and payment. The County acts only as the “Contracting Agent” for these public bodies. Any resulting contract with other public bodies shall be governed by the laws of that specific entity. It is the Contractor’s responsibility to notify the public bodies of the availability of the Contract. Fluvanna County shall not be held liable for any direct or indirect costs, damages or other claim of any kind incurred by another public body or any Contractor as a result of any cooperative procurement.
- 60. AUDIT:** The Contractor hereby agrees to retain all books, records and other documents relative to any Contract for five (5) years after final payment, or until audited by the County, whichever is sooner. The County, its authorized agents, and/or County auditors shall have full access to and right to examine any of said materials during said period.
- 61. GUARANTIES AND WARRANTIES:** All guarantees, representations and warranties required shall be furnished by the Contractor and shall be delivered to the Purchasing Agent before final payment on any Contract is made. In addition to any guarantees, representations and warranties required under the Contract, the Contractor agrees to:
- a. Save the County, its agents and employees harmless from liability of any nature or kind for the use of any copyrighted or un-copyrighted composition; secret process, patented or unpatented; invention; article or appliance furnished or used in the performance of a Contract for which the Contractor is not the patentee, assignee, licensee or owner;
 - b. Protect the County against latent defective material or workmanship and to repair or replace any damages or marring occasioned in transit or delivery;
 - c. Furnish adequate protection against damage to all work and to repair damages of any kind to the building or equipment, to the Contractor’s own work or to the work of other contractors, for which the Contractor’s workers are responsible;
 - d. Pay for all permits, licenses and fees and give all notices and comply with all laws, ordinances, rules and regulations of the County; and
 - e. Protect the County from loss or damage to County owned property while it is in the custody of the Contractor;

- f. At minimum supply all Goods or Services with the manufacturer's standard warranty, if applicable; and
 - g. For any Contract involving Services of any nature, the Contractor further agrees to:
 - i. Enter upon the performance of Services with all due diligence and dispatch, assiduously press to its complete performance, and exercise therein the highest degree of skill and competence;
 - ii. Allow Services to be inspected or reviewed by an employee of the County at any reasonable time and place selected by the County;
 - iii. Acknowledges that the County shall be under no obligation to compensate Contractor for any Services not rendered in strict conformity with the Contract; and
 - iv. Stipulates that the presence of a County Inspector shall not lessen the obligation of the Contractor for performance in accordance with the Contract requirements, or be deemed a defense on the part of the Contractor for infraction thereof. The Inspector is not authorized to revoke, alter, enlarge, relax, or release any of the requirements of any Contract. Any omission or failure on the part of the Inspector to disapprove or reject any work or material shall not be construed to be an acceptance of any such defective work or material.
- 62. PRICE REDUCTIONS:** If at any time after the date of the Bid/Contract the Contractor makes a general price reduction in the comparable price of any material covered by the Contract to customers generally, an equivalent price reduction based on similar quantities and/or considerations shall apply to any Contract for the duration of the Contract period (or until the price is further reduced). Such price reduction shall be effective at the same time and in the same manner as the reduction in the price to customers generally. For purpose of this provision, a "general price reduction" shall mean any horizontal reduction in the price of an article or service offered (1) to Contractor's customers generally, or (2) in the Contractor's price schedule for the class of customers, i.e., wholesalers, jobbers, retailers, etc., which was used as the basis for bidding on this Solicitation. An occasional sale at a lower price, or sale of distressed merchandise at a lower price, would not be considered a "general price reduction" under this provision. The Contractor shall submit his or her invoice at such reduced prices indicating on the invoice that the reduction is pursuant to the "Price Reduction" provision of the Contract documents. The Contractor in addition will within ten (10) days of any general price reduction notify the County of such reduction by letter. FAILURE TO DO SO IS A DEFAULT UNDER THE CONTRACT AND MAY RESULT IN TERMINATION OF THE CONTRACT IN THE COUNTY'S DISCRETION. The Contractor, if requested, shall furnish, within ten (10) days after the end of the Contract period, a statement certifying either (1) that no general price reduction, as defined above, was made after the date of the Bid or Contract, or (2) if any such general price reductions were made, that as provided above, they were reported to the County within ten (10) days and the County was billed at the reduced prices. Where one or more such general price reductions were made, the statement furnished by

the Contractor shall include with respect to each price reduction (1) the date when notice of any such reduction was issued, (2) the effective date of the reduction, and (3) the date when the County was notified of any such reduction.

63. COMPLIANCE WITH IMMIGRATION LAW: Pursuant to Virginia Code § 2.2-4311.1, in every Contract the following provision applies: the Contractor does not, and shall not during the performance of the Contract, knowingly employ an unauthorized alien as defined in the federal Immigration Reform and Control Act of 1986.

64. VIRGINIA STATE CORPORATION COMMISSION: Pursuant to Virginia Code § 2.2-4311.2, Any Bidder or Contractor organized as a stock or non-stock corporation, limited liability company, business trust, or limited partnership or registered as a registered limited liability partnership shall be authorized to transact business in the Commonwealth as a domestic or foreign business entity if so required by Title 13.1 or Title 50 of the Code of Virginia, or as otherwise required by law, at the time of the Bid, Proposal or any response to Solicitation and during the term of the Contract and any Contract renewal. The Contractor shall not allow its existence to lapse or its certificate of authority or registration to transact business in the Commonwealth, if so required, to be revoked or cancelled at any time during the term or any renewal of the Contract. If the Contractor fails to remain in compliance with the provisions of this Section 64, the Contract may become void at the option of the County.

65. CLAIMS PROCEDURE:

- a. The procedure for consideration by the County of contractual claims for any Contract shall be that set forth in Virginia Code § 15.2-1243, *et seq.*
- b. In addition, pursuant to Virginia Code § 2.2-4364, contractual claims, whether for money or other relief, shall be submitted in writing to the County Administrator no later than sixty (60) days after final payment; however, written notice of the Contractor's intention to file such claim shall have been given at the time of the occurrence or beginning of the work upon which the claim is based. Nothing herein shall preclude a Contract from requiring submission of an invoice for final payment within a certain time after completion and acceptance of the work or acceptance of the Goods. Pendency of claims shall not delay payment of amount agreed due in the final payment.
- c. No written decision denying a claim or addressing issues related to the claim shall be considered a denial of the claim unless the written decision is signed by the Board or the County Administrator. The contractor may not institute legal action prior to receipt of the final written decision on the claim unless the County fails to render a decision within ninety (90) days of submission of the claim. Failure of the County to render a decision within ninety (90) days shall not result in the contractor being awarded the relief claimed or in any other relief or penalty. The sole remedy for the County's failure to render a decision within 90 days shall be the contractor's right to institute immediate legal action.

- d. A Contractor may not institute legal action, prior to receipt of the County's decision on the claim, unless the County fails to render such decision within the time specified by law. A failure by the County to render a decision within the time provided by law shall be deemed a final decision denying the claim by the County.
 - e. The decision of the Board or the County Administrator shall be final and conclusive unless the Contractor appeals within six (6) months of the date of the final written decision by instituting legal action as provided in Virginia Code § 2.2-4364.
 - f. No administrative appeals procedure pursuant to Virginia Code § 2.2-4365 has been adopted for contractual claims by the County.
 - g. Nothing herein shall be construed to prevent the County from instituting legal action against any Contractor or Bidder.
- 66. NOTICES:** All written notices required or permitted under any Solicitation, Bid or Contract shall be deemed sufficient if delivered in person to the County Purchasing Agent or Bidder/Contractor, as applicable, or sent by first class mail to the County or Bidder/Contractor at the addresses set forth in the Solicitation, Bid or Contract or at such other address as a party may designate from time to time by notice given in accordance with the terms of this Section 66; except that where a Solicitation, Bid or Contract expressly requires notice to a specific individual or at a specific location, such shall control. Such notices are deemed received when actually delivered to the party or its representative or agent if hand delivered, or one (1) business day after deposited into the United States mail, if mailed.

DELIVERY

- 67. SHIPPING INSTRUCTIONS-CONSIGNMENT:** Unless otherwise specified in the Solicitation or Contract, as applicable, each case, crate, barrel, package, etc., delivered under the Contract must be plainly stenciled or securely tagged, stating the Contractor's name, purchase order number, and delivery address as indicated in the order. Where shipping containers are to be used, each container must be marked with the purchase order number, name of the Contractor, the name of the item, the item number, and the quantity contained therein. Deliveries must be made within the hours of 8:00 a.m. – 3:00 p.m. Deliveries at any other time will not be accepted unless specific arrangements have been previously made with the designated individual at the delivery point. No deliveries will be accepted on Saturdays, Sundays and holidays unless previous arrangements have been made. It shall be the responsibility of the Contractor to insure compliance with these instructions for items that are drop-shipped.
- 68. RESPONSIBILITY FOR SUPPLIES TENDERED:** The Contractor shall be responsible for the materials or supplies covered by the Contract until they are delivered

at the designated point. The Contractor shall additionally bear all risk on rejected materials or supplies after notice of rejection is tendered by the County. Rejected materials or supplies must be removed by and at the expense of the Contractor promptly after notification of rejection, unless public health and safety require immediate destruction or other disposal of rejected delivery. If rejected materials are not removed by the Contractor within ten (10) days after date of notification, the County may return the rejected materials or supplies to the Contractor at the Contractor's risk and expense or dispose of them as abandoned property.

- 69. INSPECTIONS:** The County reserves the right to conduct any test/inspection it may deem advisable to assure supplies and Services conform to the specification in the Solicitation, Bid or Contract, as applicable. Inspection and acceptance of materials or supplies will be made after delivery at destinations herein specified unless otherwise stated. Unless otherwise specified in the Contract, if inspection is made after delivery at the destination specified, the County will bear the expense of inspection except for the value of samples used in case of rejection. Final inspection shall be conclusive except in regard to latent defects, fraud or such gross mistakes as to amount to fraud. Final inspection and acceptance or rejection of the materials or supplies will be made as promptly as practicable, but failure to inspect and accept or reject materials or supplies shall not impose liability on the County for such materials or supplies as are not in accordance with the specifications.
- 70. COMPLIANCE:** Delivery must be made as ordered and in accordance with the Solicitation, Bid or Contract, as applicable, or as directed by the County when not in conflict with the Bid/Contract. The decision as to reasonable compliance with delivery terms shall be final. Burden of proof of delay in receipt of Goods by the purchaser shall rest with the Contractor. Any request for extension of time of delivery from that specified must be approved by the County, such extension applying only to the particular item or shipment affected. Unless otherwise specified in the Contract, should the Contractor be unreasonably delayed by the County, there shall be added to the time of completion a time equal to the period of such delay caused by the County. However, the Contractor shall not be entitled to claim damages or extra compensation for such delay or suspension. These conditions may vary for construction Contracts.
- 71. POINT OF DESTINATION:** All materials shipped to the County must be shipped F.O.B. DESTINATION unless otherwise stated specifically in the Solicitation, Bid or Contract, as applicable. The materials must be delivered to the "Ship To" address indicated on the purchase order or Solicitation, as applicable.
- 72. REPLACEMENT:** Materials or components that have been rejected by the County, in accordance with the terms of the Contract, shall be replaced by the Contractor at no cost to the County.
- 73. DAMAGES:** Any and all damages to property of the "County" that is the direct result of the Contractor, the employees of the Contractor and/or its subcontractors, agents, licensees, successors, or assigns, shall be the sole responsibility of the Contractor. The

property shall be repaired to its last known condition prior to the damages and/or replaced at no cost to the County. The County shall approve any and all repairs/replacements prior to acceptance of the repairs/replacement.

74. PACKING SLIPS OR DELIVERY TICKETS: All shipments shall be accompanied by Packing Slips or Delivery Tickets and shall contain the following information for each item delivered:

- a. Purchase Order Number;
- b. Name of Article and Stock Number;
- c. Quantity Ordered;
- d. Quantity Shipped;
- e. Quantity Back Ordered; and
- f. The Name of the Contractor.

Contractors are cautioned that failure to comply with these conditions shall be considered sufficient reason for refusal to accept the Goods.

75. ADDITIONAL CHARGES: No delivery charges of any kind shall be added to any invoice; except that (i) if Goods are expressly bought F.O.B. "shipping point" under the Contract and the Contractor prepays transportation, then delivery charges shall be added to invoices; and (ii) if express delivery is authorized and substituted by the County on orders for the method specified in the Contract, then the difference between freight or mail and express charges may be added to invoice.

76. METHOD AND CONTAINERS: Unless otherwise specified, Goods shall be delivered in commercial packages in standard commercial containers, so constructed as to ensure acceptance by common or other carrier for safe transportation to the point of delivery. Containers become the property of the County unless otherwise specified by bidder.



**COUNTY OF FLUVANNA, VIRGINIA
(IFB) #2018-01
FARM HERITAGE MUSEUM BARN**

ADDENDUM # 1:

Reference – Invitation for Bid: IFB #2018-01
Title of Request for Proposal: FARM HERITAGE MUSEUM BARN
Issue Date: August 30, 2017
Bid Due Date and Time: October 23, 2017 at 2 p.m. EST

The above IFB #2018-01 is hereby amended and modified as follows:

1. Please see attached marked up site plan that clarifies parts of this site plan are not included in this project. The only items on the opposite side of the driveway from the building location, that are to be included is a Row of 10, crush and run/21A gravel, spaces, including 2 Handicap Accessible Parking spaces, ADA accessible route and signage.
2. Please note that work hours are Monday thru Friday park hours of sun up to sun down. If needed, weekend work can be scheduled and approved by the Director of Parks and Rec. and is contingent on any pre-planned public use.
3. Additional fill dirt can be used from a "Borrow" pile on the property, however, please note this site is approximately 0.7 mile from the build site. It will be the contractor's responsibility to load and transport.
4. The level spreaders for the Farm Museum will be constructed in accordance with standards from the Virginia E&S manual for "Level Spreader with Rigid Lip". This will require a wire mesh basket containing coarse aggregate to be installed on the down-stream side of each level spreader.

Note: A signed acknowledgment of this addendum must be received at the location indicated on the IFB either prior to the bid due date and hour or attached to your bid. Signature on this addendum does not substitute for your signature on the original bid document. The original bid document must be signed.

Very truly yours,

Cyndi Toler, Purchasing Officer
Fluvanna County, Virginia
132 Main Street
Palmyra, VA 22963
(434) 591-1930

Name of Firm: _____

BY: _____

Signature of duly authorized representative

Title: _____

Date: _____

DRAFT

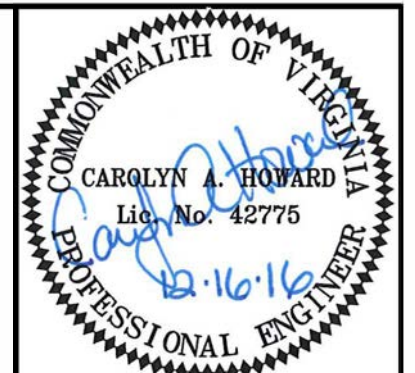

Draper Aden Associates
 Engineering • Surveying • Environmental Services
 Charlottesville, VA
 110 Avon Street
 Charlottesville, VA 22902
 434-995-0700 Fax: 434-995-2105
 www.daa.com

• Richmond, VA • Coats, NC
 • Blacksburg, VA • Fayetteville, NC
 • Hampton Roads, VA • Northern Virginia

EROSION & SEDIMENT CONTROL LEGEND

No.	TITLE	KEY	SYMBOL
3.02	TEMPORARY STONE CONSTRUCTION ENTRANCE	(CE)	[Symbol]
3.05	SILT FENCE	(SF)	[Symbol]
3.07	STORM DRAIN INLET PROTECTION	(IP)	[Symbol]
3.17	STORMWATER CONVEYANCE CHANNEL	(SCC)	[Symbol]
3.18	OUTLET PROTECTION	(OP)	[Symbol]
3.20	ROCK CHECK DAM	(CD)	[Symbol]
3.21	LEVEL SPREADER	(LS)	[Symbol]
3.30	TOPSOILING	(TO)	[Symbol]
3.31	TEMPORARY SEEDING (THROUGHOUT UNPAVED AREAS W/IN LIMITS OF DISTURBANCE)	(TS)	[Symbol]
3.32	PERMANENT SEEDING (THROUGHOUT UNPAVED AREAS W/IN LIMITS OF DISTURBANCE)	(PS)	[Symbol]
3.35	MULCHING (THROUGHOUT UNPAVED AREAS W/IN LIMITS OF DISTURBANCE)	(MU)	[Symbol]
3.36	SOIL STABILIZATION BLANKETS & MATTING	(B/M)	[Symbol]
3.39	DUST CONTROL (ENTIRE AREA W/IN LIMITS OF DISTURBANCE)	(DC)	[Symbol]

PAVEMENT & DEMOLITION LEGEND

[Symbol] GRAVEL PARKING AND PATH (SEE SECTION, SHEET C5.1)

[Symbol] REMOVE WOODEN WHEEL STOPS

GRADING LEGEND

SW: GRAVEL PATH ELEVATION
 INV: SWALE INVERT ELEVATION
 G: GROUND ELEVATION
 P: GRAVEL ROAD/PARKING ELEVATION
 ME: MATCH EXISTING ELEVATION
 ±: APPROXIMATE EXISTING ELEVATION; CONTACT ENGINEER IF ACTUAL FIELD ELEVATION VARIES BY ±1"

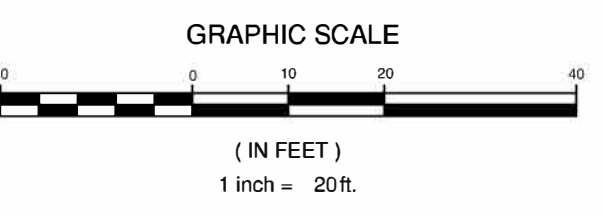
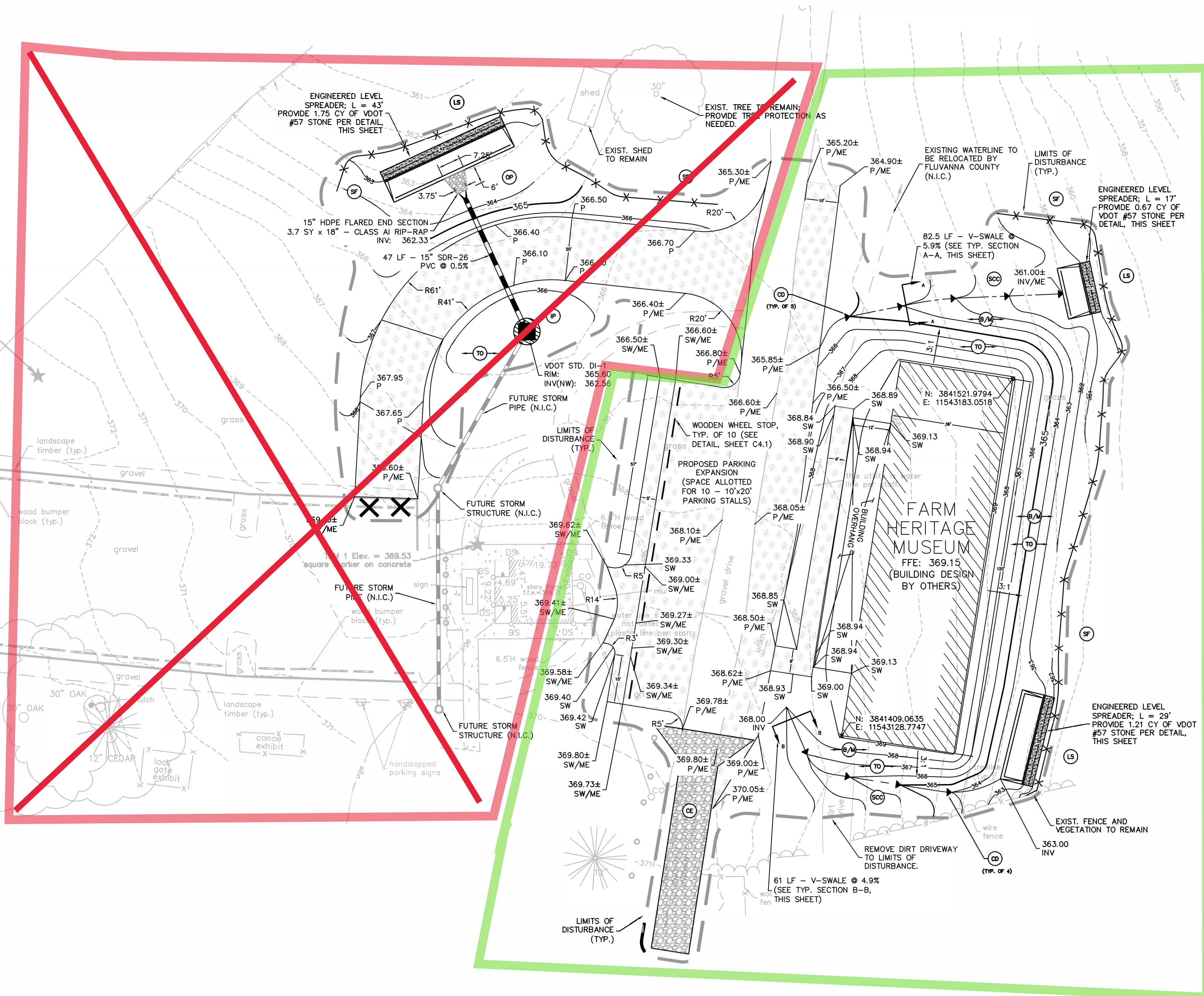
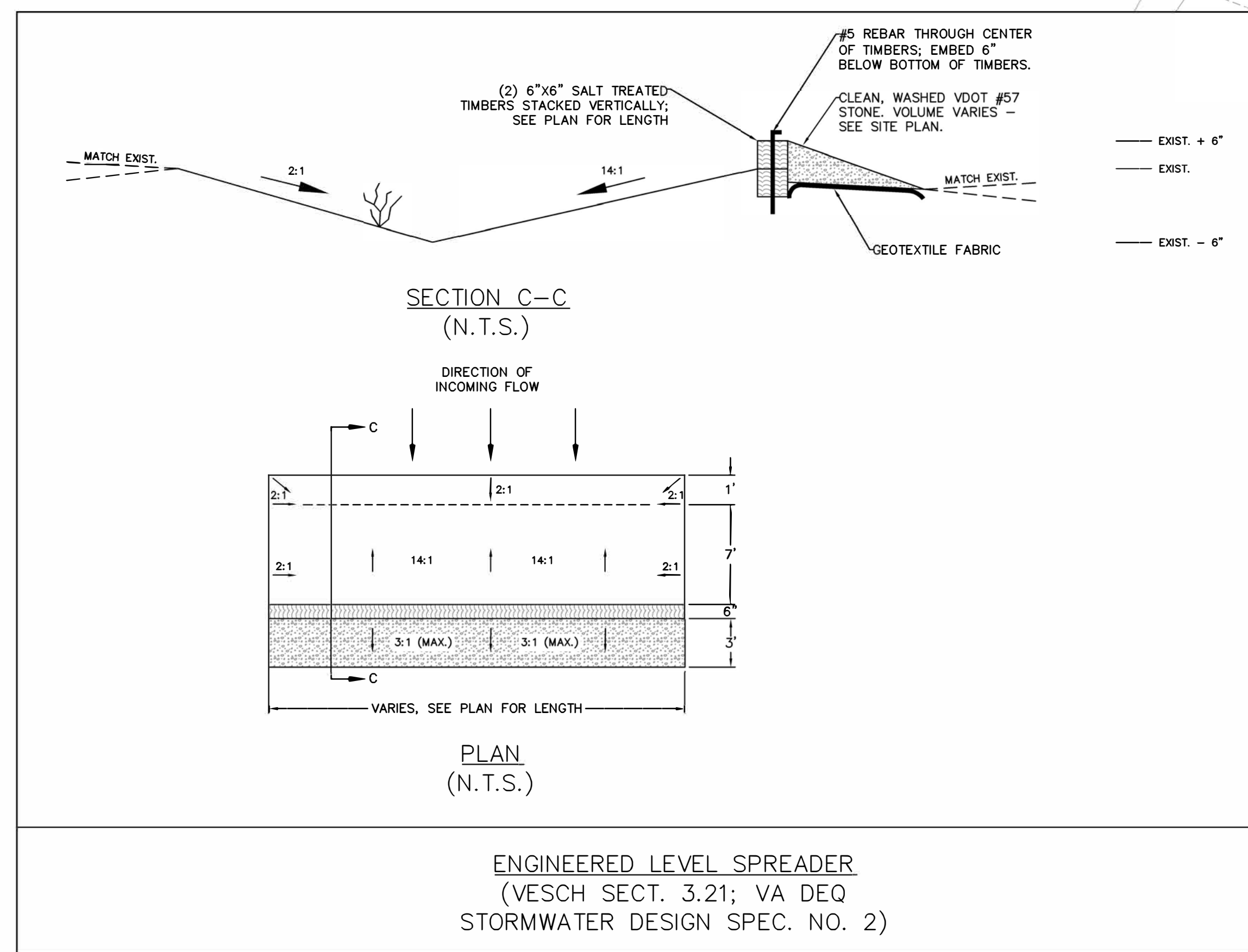

**SITE PLAN
 FARM HERITAGE MUSEUM
 & PARKING LOT IMPROVEMENTS
 PALMYRA, VIRGINIA**

REVISIONS

DESIGNED BY:	CAH
DRAWN BY:	CEP
CHECKED BY:	CAH
SCALE:	1" = 20'
DATE:	DECEMBER 16, 2016
PROJECT NUMBER:	R13457C-11
C3.0	

Exhibit 2

DRAFT



COUNTY OF FLUVANNA

"Responsive & Responsible Government"

132 Main Street
 P.O. Box 540
 Palmyra, VA 22963
 (434) 591-1910
 Fax (434) 591-1911
 www.fluvannacounty.org

IFB 2018-01	INVITATION TO BID: FARM HERITAGE MUSEUM BARN	BID OPENING: October 23, 2017 AT 2:00 p.m.
NOTICE TO ALL BIDDERS: All equipment and/or services provided under this invitation for Bid shall conform to the specifications and all terms and conditions as set forth.		

Have all Specifications included in this Invitation for Bid been met?

Yes [] No

If no, please list all exceptions in detail on separate sheet.

Person to contact regarding this bid: John Shourds

Title: project manager Phone: (c) 619-208-6333

Email Address: topguncandidates@gmail.com

Name of person authorized to bind the Firm: John L. Fuog

Signature: John L. Fuog president Date: 10/20/17

Name of Company: InterBuild, inc, T/A Fuog/InterBuild, Inc

Address: P.O. Box 7, Pirceville, VA 014
(physical address: 510 EAST Main Street, Pirceville, VA 20132)

By signing this bid, bidder certifies, acknowledges, understands and agrees to be bound by the conditions set forth in the contents of the bid including the General Terms and Conditions.

Three hundred Seven Thousand One Hundred Fourteen Dollars & no cents

Work Description	Price
LUMP SUM COST FOR FARM HERITAGE MUSEUM BARN	\$307,114.00

Optional Pricing (not required for this bid award)

Work Description	Price



**COUNTY OF FLUVANNA, VIRGINIA
(IFB) #2018-01
FARM HERITAGE MUSEUM BARN**

ADDENDUM # 1:

Reference – Invitation for Bid: IFB #2018-01
Title of Request for Proposal: FARM HERITAGE MUSEUM BARN
Issue Date: August 30, 2017
Bid Due Date and Time: October 23, 2017 at 2 p.m. EST

The above IFB #2018-01 is hereby amended and modified as follows:

1. Please see attached marked up site plan that clarifies parts of this site plan are not included in this project. The only items on the opposite side of the driveway from the building location, that are to be included is a Row of 10, crush and run/21A gravel, spaces, including 2 Handicap Accessible Parking spaces, ADA accessible route and signage.
2. Please note that work hours are Monday thru Friday park hours of sun up to sun down. If needed, weekend work can be scheduled and approved by the Director of Parks and Rec. and is contingent on any pre-planned public use.
3. Additional fill dirt can be used from a "Borrow" pile on the property, however, please note this site is approximately 0.7 mile from the build site. It will be the contractor's responsibility to load and transport.
4. The level spreaders for the Farm Museum will be constructed in accordance with standards from the Virginia E&S manual for "Level Spreader with Rigid Lip". This will require a wire mesh basket containing coarse aggregate to be installed on the down-stream side of each level spreader.

Note: A signed acknowledgment of this addendum must be received at the location indicated on the IFB either prior to the bid due date and hour or attached to your bid. Signature on this addendum does not substitute for your signature on the original bid document. The original bid document must be signed.

Very truly yours,

Cyndi Toler, Purchasing Officer
Fluvanna County, Virginia
132 Main Street
Palmyra, VA 22963
(434) 591-1930

Name of Firm: Frog / The back side. Inc

BY: John C. Frog pres.

Signature of duly authorized representative

Title: president

Date: 10/24/17

addendum #1



COUNTY OF FLUVANNA, VIRGINIA
(IFB) #2018-01
FARM HERITAGE MUSEUM BARN

ADDENDUM # 2:

Reference – Invitation for Bid: IFB #2018-01
 Title of Request for Proposal: FARM HERITAGE MUSEUM BARN
 Issue Date: August 30, 2017
 Bid Due Date and Time: October 23, 2017 at 2 p.m. EST

The above IFB #2018-01 is hereby amended and modified as follows:

1. The following are clarifications from questions received that supplement IFB #2018-01 FARM HERITAGE MUSEUM BARN:
 - a. Pg4 of IFB item viii – “Period appropriate locking mechanism” What is the Period of Design?
 - i. Design should be early 20th century.
 - b. Pg4 of IFB item x – Item calls out “All doors shall be exterior doors”, sheet 3 of 8, Doors A & B look to be “built on site barn doors, Please Clarify
 - i. Doors A & B are barn doors constructed on-site. The call-out applies to entry doors.
 - c. Pg4 of IFB item ix – “All windows...and operational”, Please clarify that the custom windows on Sheet 2 of 8 are fixed windows.
 - i. The custom windows on sheet 2 of 8 should be fixed, not operational.
 - d. Sheet 1 of 8 - Please clarify species of 10” diameter log post.
 - i. Locust
 - e. Sheet 5 of 8 – Detail 2/5 does not match the roof framing plan on Sheet 5 of 8, Please clarify.
 - i. Please see updated sheet 5 attached.
 - f. Sheet 5 of 8 – Detail 1/5 Please clarify no gypsum ceilings or walls, exterior sheathing to be textured plywood with the texture facing into the building.
 - i. Please see updated sheet 5 attached.
 - g. Sheet 5 of 8 – Detail 1/5, Please clarify that the gutters and downspouts are to be period appropriate as well.
 - i. The gutters & downspouts should be period-specific
 - h. Sheet 1 of 8 – Detail 1/8 shows fixed acrylic skylights, Pg4 of the IFB states “Operable Skylights” Please clarify.
 - i. Skylights should be manually operable.
 - i. Sheet 4 of 8 – Detail ¾, Detail calls for “Simpson CB66”, non-stand-off post base. The Simpson CB66 has a 5 ½” throat, the post is 10” in diameter, Please clarify.
 - i. Contractor should use an appropriately-sized stand-off post base by the same manufacturer (or approved equal).
 - j. Sheet 1 of 8 – Cupola Detail – What is the cupola roofing material.
 - i. The roofing on the cupola should match the roofing on the rest of the building.

- k. Pg4 of IFB note viii – “Hardware to be period” does this apply to the exterior 3/0 x 6/8 door and the 4/0 x 4/0 windows, please clarify.
 - i. Contractor should do the best they can to match the other period-hardware, however, if it is cost prohibitive, please quote the lower cost with period hardware as an add-alternate?
- l. Sheet 5 of 8 – Detail 4/5, the “Box Eave detail” where is this located on the building, please clarify.
 - i. Please disregard the “Box Eave detail” it will not be a part of the final build.
- m. Sheet 5 of 8 – Note 5, “Glue lam beams to be western species combination 24F V-4”, “Western Specie” in Glue Lam beams refers to Douglas Fir which is economical on the west coast. East Coast Glue lams are typically Southern Yellow Pine which is more readily available on the East Coast, Please advise, if Southern Yellow Pine is acceptable over Douglas Fir.
 - i. Glue lam beams shall be Southern Yellow Pine
- n. Sheet 7 of 8 – Note 2, Rebar grounding, this is a special code that normally applies to wet contact concrete or cell tower foundations. In addition this is a common local code in the Pacific Northwest. Please advise that the County is requiring rebar grounding in this building.
 - i. Electrical grounding shall be in accordance with locally applicable building code.

Note: A signed acknowledgment of this addendum must be received at the location indicated on the IFB either prior to the bid due date and hour or attached to your bid. Signature on this addendum does not substitute for your signature on the original bid document. The original bid document must be signed.

Very truly yours,

Cyndi Toler, Purchasing Officer
 Fluvanna County, Virginia
 132 Main Street
 Palmyra, VA 22963
 (434) 591-1930

Name of Firm: Joag Interwild Inc

BY: Joh C. Joag

Signature of duly authorized representative

Title: president

Date: 10/20/17

addendum # 2



Project: County of Fluvanna, Virginia
IFB # 2018-01
FARM HERITAGE MUSEUM BARN
Issue Date: August 30, 2017
Due Date: October 23, 2017 at 2 p.m. EST

October 20, 2017

Contractor Bidding:
Fuog/InterBuild, Inc.
P O Box 237
Purcellville, VA 20132

To whom it may concern:

I am John Shourds, the project manager who will oversee the construction of this project. Our central office is located at 510 East Main Street, Purcellville, Virginia with an auxiliary storage facility located in St. Louis, outside of Middleburg, Virginia. As the project manager, I will schedule work with our crew and sub contractors. Tom Miller will be in charge of the erosion and sediment control (certified land disturber) and the excavation. I will be responsible for the submission of payments, which will come from our in house accountant, Kathy Panfil. **(Ref: 4-D)**

For Clarification, I am acknowledging that I fully understand the IFB, the requirements and processes in order to complete this project and have read/understand the 2 Addendums. **(Ref: 4-C)**

Fuog/InterBuild, Inc., is an established and well-respected Class A building contractor, licensed in Virginia, West Virginia, and Maryland. Three decades ago, Fuog began with expertise in equine facilities, such as barns and indoor/outdoor arenas.

After 36 years, Fuog/InterBuild, Inc. has expanded and evolved into a leading contracting company with a variety of services that include Barns, wineries, arenas, custom homes, garages, renovations, metal buildings, Butler pre-engineered metal buildings, commercial buildings, grading, excavation and infrastructure. Along with expert construction, we can integrate contemporary energy-saving technology, such as solar and geothermal systems. Fuog/InterBuild has been in business since 1981.

Fuog/InterBuild, Inc. holds memberships with the ICC (International Code Council). Additionally, Fuog/InterBuild has been a member of the National Frame Builders Association since 1991 which is a trade association centered out of Chicago, Illinois and covers all of the continental United States. Through the years, Fuog has been the winner of many awards from both trade associations and vendors of materials. See list below:

- **2014 NFBA First Place Winner, Building of the Year, Horse Barn 5K sq. ft and under**
- **2013 NFBA First Place Winner, Building of the Year, Experts Division**
- **2013 Butler High Performance Builder**
- **2013 NFBA Second Place Building of the Year, Retrofit/Remodel Division**
- **2011 NFBA First Place Winner, Building of the Year**
- **2011 NFBA Judges Choice**
- **2010 NFBA Third Place Winner, Building of the Year**
- **2009 Butler High Performance Builder Award, Butler Manufacturing**
- **2009 Appointed Butler Builder Distributor Designation**
- **2008 Award Of Excellence for Superior Sales and Service, Norandex Corp**
- **2000 Award to Phil Carter, National Foreman of the Year, NFBA**
- **1999 Award for Building of the Year, Fabral Metal Wall/Roof System, Agriculture/Farm Buildings**
- **1999 NFBA Building of the Year, Horse barn over 3K sq. ft.**
- **1992 NFBA Award for Machinery Storage/Workshop Building of the Year**

(Ref: 4-D)

In conclusion, I have attached my personal resume with this letter. I have extensive experience in the orchestration of projects and am currently working with Penn National, Charles Town, WV, restoring the horse barns damaged by a tornado in August. It is my pleasure to submit this bid to the County of Fluvanna for your consideration.

Sincerely, 

John Shourds
 Project Manager
 Fuog/InterBuild, Inc.
 Office: 540-338-2306
 Cell # 619-208-6333

JOHN SHOURDS**Purcellville, VA****619-208-6333****topguncandidates@gmail.com**

Summary

Operations and Business development leader with more than 35 years construction industry experience in project management, strategic relationship building, operational and supervisory roles. Passion for building projects and teams, dedication to customer satisfaction for the long term.

Work History and Experience**Fuog Interbuild Project Manager 2017**

Oversee the team members, projects and tools that help drive Fuog Interbuild's operational and revenue goals, project by project, by developing, estimating, bidding and building custom commercial and residential construction projects, from \$100k to \$10M, that meet or exceed both the customer expectations as well as engineering and architectural guidelines, with a special focus on custom poured foundations, pole barns, carpentry and custom millwork.

Manage each project to ensure that it achieves the highest levels of quality and customer satisfaction, while adhering to scheduling and budget constraints.

Top Gun Consulting Group Vice President 1999 - 2016

Developed, implemented and managed start up Construction Consulting Company, including all of the recruiting, hiring, empowering, mentoring, and managing of over sixty employees and team managers.

Set up, developed and led weekly team meetings to ensure the highest and most efficient SOP, Systems and focus, maximizing sales, brand/company loyalty and customer satisfaction.

Developed, wrote, negotiated and secured contracts with top executives in many Fortune 500 national and international companies.

Studied, researched, wrote and implemented yearly budget and sales goals while always looking to improve efficiency, leading to manageable and achievable fiscal goals, with total P&L responsibility.

The Home Depot Corporation Store Manager 1992 -1999

Directed sales, managed operations to transform a lower mid-level performing store into the highest performing and highest volume store in our region, achieving the #3 spot in the Northeast Division, and closing annual sales of over \$75M.

Took advantage of business opportunities and improved operational and occupancy efficiencies, to increase store's sales by 20% (compared to previous year over year sales) for two years running, thereby increasing our margins and turns exponentially, leading to a huge increase in GM -ROI.

Directed and managed the recruiting, hiring, training and staff development of over 280 management, supervisory, training, sales, customer service, technical and administrative support personnel, as well as responsible for negotiating numerous contracts with vendors, partners, etc.

Progressively responsible positions from Salesperson to Department Manager, to Assistant Manager and eventually promoted to Store Manager.

Previous Work History and Education

Previous experience includes 14 years as a Union Carpenter, including completing 4 year Apprenticeship Program in custom carpentry and millwork, as well as apprenticeship program under the owner of a medium-sized residential plumbing contractor (before and while attending college at UM).

University of Maryland - College Park, Maryland, Bachelor of Science – Business

First place in "Outward Bound" Team Development Training



Project: County of Fluvanna, Virginia
IFB # 2018-01
FARM HERITAGE MUSEUM BARN
Issue Date: August 30, 2017
Due Date: October 23, 2017 at 2 p.m. EST

October 20, 2017

Contractor Bidding:
Fuog/InterBuild, Inc.
P O Box 237
Purcellville, VA 20132

Projected Time Schedule:

To whom it may concern,

The proposed Farm Heritage Museum Barn Project will be constructed in **eight weeks** time from **start to finish**. The start time is **NOT** the date of the "award and notice to proceed" but rather when the grading and building permit gets out of plans review and is approved from Fluvanna county.

The project will proceed starting with site work, foundation, framing carpentry, concrete, electrical including smoke detectors, roofing, exterior siding & stain, doors & windows & skylights, hardware, punch-out, and final grading.

A weekly progress report and or a job walk will be provided to Cindi Toler at Fluvanna County...

Sincerely,



John Shourds
Project Manager
Fuog/ InterBuild, Inc
Office: 540-338-2306
Cell # 619-208-6333

County of Fluvanna, Virginia
IFB # 2018-01
FARM HERITAGE MUSEUM BARN
Issue Date: August 30, 2017
Due Date: October 23, 2017 at 2 p.m. EST

Contractor Bidding:
Fuog/InterBuild, Inc.
P O Box 237
Purcellville, VA 20132

SUB CONTRACRTOR LIST FOR HERITAGE BARN:

- 1. A & I Custom Building**
- 2. Southern Electric**
- 3. Potomac Concrete**

VENDOR DATA SHEET

Note: The following information is required as part of your response to this solicitation. Failure to complete and provide this sheet may result in finding your bid nonresponsive.

1. Qualification: The vendor must have the capability and capacity in all respects to satisfy fully all of the contractual requirements.

2. Vendor's Primary Contact:

Name: JOHN L. FROG Phone: 590 338 2306

3. Years in Business: Indicate the length of time you have been in business providing this type of good or service: 36 Years 9 Months

4. Vendor Information:

FIN or FEI Number: 541256048 If Company, Corporation, or Partnership
SSN: _____ (If Vendor is a sole proprietor)

5. Indicate below a listing of at least four (4) current or recent accounts, either commercial or governmental, that your company is servicing, has serviced, or has provided similar goods. Include the length of service and the name, address, and telephone number of the point of contact.

Company: Toll Brothers, Contact: Chris Flickinger
Phone: 301-780-3595 Email: cflickinger@tollbrothersinc.com
Dates of Service: 2015-2016 \$\$ Value: \$1,500,00.00

Company: F. H. Paschen Contact: Scott Page
Phone: 703-245-0280 Email: spage@fhpaschen.com
Dates of Service: 2015- current \$\$ Value: \$500,000.00

Company: Town of Purcellville Contact: Derek Copeland
Phone: 540-338-7421 Email: dcopeland@purcellvilleva.gov
Dates of Service: \$\$ Value: \$200,000.00

Company: St. Brides Contact: Barbara Roux
Phone: 703-517-7387 Email: bwroux@gmail.com
Dates of Service: 2011-2012 \$\$ Value: \$3,200,000.00

By my signature below, I, as a duly authorized representative of the entity named below, certify the accuracy of the foregoing information:

Interwild Inc 71A Frog Interwild Date: 10/20/17
Legal Name of Entity if Applicable

By: John L. Frog president (SEAL) Print Name: John L. Frog
Signature of Authorized Representative Print Title: President

Vendor Certification (for a Sole Proprietor):

Signature (SEAL) Print Name: _____ Date: _____

PLEASE RETURN THIS PAGE WITH PROPOSAL SUBMISSION – [REQUIRED]



CERTIFICATE OF LIABILITY INSURANCE

 DATE (MM/DD/YYYY)
 10/19/2017

THIS CERTIFICATE IS ISSUED AS A MATTER OF INFORMATION ONLY AND CONFERS NO RIGHTS UPON THE CERTIFICATE HOLDER. THIS CERTIFICATE DOES NOT AFFIRMATIVELY OR NEGATIVELY AMEND, EXTEND OR ALTER THE COVERAGE AFFORDED BY THE POLICIES BELOW. THIS CERTIFICATE OF INSURANCE DOES NOT CONSTITUTE A CONTRACT BETWEEN THE ISSUING INSURER(S), AUTHORIZED REPRESENTATIVE OR PRODUCER, AND THE CERTIFICATE HOLDER.

IMPORTANT: If the certificate holder is an ADDITIONAL INSURED, the policy(ies) must have ADDITIONAL INSURED provisions or be endorsed. If SUBROGATION IS WAIVED, subject to the terms and conditions of the policy, certain policies may require an endorsement. A statement on this certificate does not confer rights to the certificate holder in lieu of such endorsement(s).

PRODUCER Hottle and Associates P.O. Box 3473 Warrenton, VA 20188 H. Powers Thomas 540-351-0862	CONTACT NAME: H. Powers Thomas PHONE (A/C, No, Ext): 540-351-0862 FAX (A/C, No): 540-216-3769 E-MAIL ADDRESS: <table style="width: 100%; border-collapse: collapse;"> <tr> <td style="width: 70%; text-align: center;">INSURER(S) AFFORDING COVERAGE</td> <td style="width: 30%; text-align: center;">NAIC #</td> </tr> <tr> <td>INSURER A: Erie Insurance Exchange</td> <td style="text-align: center;">26271</td> </tr> <tr> <td>INSURER B:</td> <td></td> </tr> <tr> <td>INSURER C:</td> <td></td> </tr> <tr> <td>INSURER D:</td> <td></td> </tr> <tr> <td>INSURER E:</td> <td></td> </tr> <tr> <td>INSURER F:</td> <td></td> </tr> </table>	INSURER(S) AFFORDING COVERAGE	NAIC #	INSURER A: Erie Insurance Exchange	26271	INSURER B:		INSURER C:		INSURER D:		INSURER E:		INSURER F:	
INSURER(S) AFFORDING COVERAGE	NAIC #														
INSURER A: Erie Insurance Exchange	26271														
INSURER B:															
INSURER C:															
INSURER D:															
INSURER E:															
INSURER F:															
INSURED Fuog InterBuild, Inc John Fuog P.O. Box 237 Purcellville, VA 20134-0237															

COVERAGES **CERTIFICATE NUMBER:** **REVISION NUMBER:**

THIS IS TO CERTIFY THAT THE POLICIES OF INSURANCE LISTED BELOW HAVE BEEN ISSUED TO THE INSURED NAMED ABOVE FOR THE POLICY PERIOD INDICATED. NOTWITHSTANDING ANY REQUIREMENT, TERM OR CONDITION OF ANY CONTRACT OR OTHER DOCUMENT WITH RESPECT TO WHICH THIS CERTIFICATION MAY BE ISSUED OR MAY PERTAIN, THE INSURANCE AFFORDED BY THE POLICIES DESCRIBED HEREIN IS SUBJECT TO ALL THE TERMS, EXCLUSIONS AND CONDITIONS OF SUCH POLICIES. LIMITS SHOWN MAY HAVE BEEN REDUCED BY PAID CLAIMS.

INSR LTR	TYPE OF INSURANCE	ADDL INSD	SUBR WVD	POLICY NUMBER	POLICY EFF (MM/DD/YYYY)	POLICY EXP (MM/DD/YYYY)	LIMITS
A	<input checked="" type="checkbox"/> COMMERCIAL GENERAL LIABILITY <input type="checkbox"/> CLAIMS-MADE <input checked="" type="checkbox"/> OCCUR GEN'L AGGREGATE LIMIT APPLIES PER: <input checked="" type="checkbox"/> POLICY <input checked="" type="checkbox"/> PRO-JECT <input type="checkbox"/> LOC OTHER:			Q46-0153563	10/01/2017	10/01/2018	EACH OCCURRENCE \$ 1,000,000 DAMAGE TO RENTED PREMISES (Ea occurrence) \$ 1,000,000 MED EXP (Any one person) \$ 5,000 PERSONAL & ADV INJURY \$ 1,000,000 GENERAL AGGREGATE \$ 2,000,000 PRODUCTS - COMP/OP AGG \$ 2,000,000
A	AUTOMOBILE LIABILITY <input checked="" type="checkbox"/> ANY AUTO OWNED AUTOS ONLY <input type="checkbox"/> SCHEDULED AUTOS <input checked="" type="checkbox"/> HIRED AUTOS ONLY <input checked="" type="checkbox"/> NON-OWNED AUTOS ONLY			Q10-0140441	10/01/2017	10/01/2018	COMBINED SINGLE LIMIT (Ea accident) \$ 1,000,000 BODILY INJURY (Per person) \$ BODILY INJURY (Per accident) \$ PROPERTY DAMAGE (Per accident) \$
A	<input checked="" type="checkbox"/> UMBRELLA LIAB <input checked="" type="checkbox"/> OCCUR <input type="checkbox"/> EXCESS LIAB <input type="checkbox"/> CLAIMS-MADE DED RETENTION \$			Q34-0171377	10/01/2017	10/01/2018	EACH OCCURRENCE \$ 10,000,000 AGGREGATE \$
A	WORKERS COMPENSATION AND EMPLOYERS' LIABILITY ANY PROPRIETOR/PARTNER/EXECUTIVE OFFICER/MEMBER EXCLUDED? (Mandatory in NH) Y/N N/A If yes, describe under DESCRIPTION OF OPERATIONS below			Q88-5102102	04/01/2017	04/01/2018	<input checked="" type="checkbox"/> PER STATUTE <input type="checkbox"/> OTH-ER E.L. EACH ACCIDENT \$ 1,000,000 E.L. DISEASE - EA EMPLOYEE \$ 1,000,000 E.L. DISEASE - POLICY LIMIT \$ 1,000,000
A	Property Section			Q46-0153563	10/01/2017	10/01/2018	

DESCRIPTION OF OPERATIONS / LOCATIONS / VEHICLES (ACORD 101, Additional Remarks Schedule, may be attached if more space is required)

CERTIFICATE HOLDER**CANCELLATION**

Fuog Interbuild Inc John Fuog PO Box 237 Purcellville, VA 20134	SHOULD ANY OF THE ABOVE DESCRIBED POLICIES BE CANCELLED BEFORE THE EXPIRATION DATE THEREOF, NOTICE WILL BE DELIVERED IN ACCORDANCE WITH THE POLICY PROVISIONS. AUTHORIZED REPRESENTATIVE <i>Virginia B. Ward</i>
--	--



WARRANTY

Fuog/InterBuild, Inc. states that the building is warranted for workmanship for the period of five (5) years from the date of substantial completion.

DATE: 10/20/17

John L. Fuog
John L. Fuog

President
President
Fuog/InterBuild, Inc.

PROOF OF AUTHORITY TO TRANSACT BUSINESS IN VIRGINIA

THIS FORM MUST BE SUBMITTED WITH YOUR PROPOSAL/BID. FAILURE TO INCLUDE THIS FORM MAY RESULT IN REJECTION OF YOUR PROPOSAL/BID

Pursuant to Virginia Code §2.2-4311.2, an Offeror/Bidder organized or authorized to transact business in The Commonwealth pursuant to Title 13.1 or Title 50 of the Code of Virginia shall include in its proposal/bid the identification number issued to it by the State Corporation Commission ("SCC"). Any Offeror/Bidder that is not required to be authorized to transact business in the Commonwealth as a foreign business entity under Title 13.1 or Title 50 of the Code of Virginia or as otherwise required by law shall include in its proposal/bid a statement describing why the Offeror/Bidder is not required to be so authorized. Any Offeror/Bidder described herein that fails to provide the required information shall not receive an award unless a waiver of this requirement and the administrative policies and procedures established to implement this section is granted by the County Administrator, as applicable. If this quote for goods or services is accepted by the County of Fluvanna, Virginia, the undersigned agrees that the requirements of the Code of Virginia Section 2.2-4311.2 have been met.

Please complete the following by checking the appropriate line that applies and providing the requested information. **PLEASE NOTE: The SCC number is NOT your federal ID number or business license number.**

A. Offeror/Bidder is a Virginia business entity organized and authorized to transact business in Virginia by the SCC and such vendor's Identification Number issued to it by the SCC is 02501146.

B. Offeror/Bidder is an out-of-state (foreign) business entity that is authorized to transact business in Virginia by the SCC and such vendor's Identification Number issued to it by the SCC is _____.

C. Offeror/Bidder does not have an Identification Number issued to it by the SCC and such vendor is not required to be authorized to transact business in Virginia by the SCC for the following reason(s):

Please attach additional sheets if you need to explain why such Offeror/Bidder is not required to be authorized to transact business in Virginia.

Legal Name of Company (as listed on W-9): InterBuild, INC, T/A Fuog/InterBuild, Inc

Legal Name of Offeror/Bidder: Fuog/InterBuild, Inc.

Date: 10/17/17

Authorized Signature: John L. Fuog president

Print or Type Name and Title: John L. Fuog president

PLEASE RETURN THIS PAGE WITH PROPOSAL SUBMISSION - [REQUIRED]

OFFEROR STATEMENT

The undersigned Offeror hereby certifies that the Offeror has carefully examined all instructions, plans, conditions, specifications and other documents or items of this Request for Proposal and hereby submits this Proposal pursuant to such instructions, plans, conditions, specifications and other documents or items.

Complete if Offeror is an Entity:

WITNESS the following duly authorized signature and seal:

Name of Entity: Interbuild Inc T/A Fuog Interbuild Inc
By: John L. Fuog president (SEAL)
Signature
Print Name: JOHN L. FUOG
Print Title: president

STATE OF Virginia
COUNTY/CITY OF Loudoun, to-wit:

The foregoing instrument was acknowledged before me this 20 day of Oct (month), 2017 (year) by John L. Fuog (Print Name), president (Print Title) on behalf of Fuog Interbuild Inc (Name of Entity).

[Signature] [SEAL]
Notary Public

My commission expires: _____
Notary registration number: _____



Complete if Offeror is a Sole Proprietor:

Witness the following signature and seal:

Signature (SEAL)
Print Name: _____

STATE OF _____
COUNTY/CITY OF _____, to-wit:

The foregoing instrument was acknowledged before me this _____ day of _____ (month), _____ (year) by _____ (Print Name), a sole proprietor.

Notary Public [SEAL]

My commission expires: _____
Notary registration number: _____

PLEASE RETURN THIS PAGE WITH PROPOSAL SUBMISSION – [REQUIRED]

CERTIFICATE OF NO COLLUSION:

The undersigned, acting on behalf of Interbuild Inc, does hereby certify in connection with the procurement and proposal to which this Certificate of No Collusion is attached that:

This proposal is not the result of, or affected by, any act of collusion with another person engaged in the same line of business or commerce; nor is this proposal the result of, or affected by, any act of fraud punishable under Article 1.1 of Chapter 12 of Title 18.1 of the Code of Virginia, 1950, as amended (18.2-498.1 et seq.).

The undersigned declares that the person or persons signing this proposal is/are fully authorized to sign the proposal on behalf of the firm listed and to fully bind the firm listed to all conditions and provisions thereof.

Respectfully submitted this 20th day of October, 2015.

Interbuild Inc T/A Fuog/Interbuild Inc
Legal Name of Entity

By: John L. Fuog president (SEAL)
Signature of Authorized Representative

Print Name: John L. Fuog

Print Title: President

Date: 10/20/17

ACKNOWLEDGEMENT

State of Virginia
In the County/City of Loudoun , to-wit:

The foregoing Certification of No Collusion was subscribed and sworn to before me by John L. Fuog (Print Name), President (Print Title) on behalf of Fuog Interbuild Inc (Print Name of Entity) on this 20th day of October (month), 17 (year).

[Signature]

Notary Public

My commission expires: 9.30.21

Registration Number: 7720085



PLEASE RETURN THIS PAGE WITH PROPOSAL SUBMISSION – [REQUIRED]

COMMONWEALTH of VIRGINIA

Department of Professional and Occupational Regulation
9960 Mayland Drive, Suite 400, Richmond, VA 23233
Telephone: (804) 367-8500

EXPIRES ON
08-31-2019

NUMBER
2701024950

BOARD FOR CONTRACTORS
CLASS A CONTRACTOR
CLASSIFICATIONS CBC RBC



INTERBUILD INC
PO BOX 237
PURCELLVILLE, VA 20134



Status can be verified at <http://www.dpor.virginia.gov>

Jay W. DeBoer
Jay W. DeBoer, Director

(SEE REVERSE SIDE FOR PRIVILEGES AND INSTRUCTIONS)

DPOR-LIC (02/201

Commonwealth OF Virginia



State Corporation Commission

CERTIFICATE OF GOOD STANDING

I Certify the Following from the Records of the Commission:

That INTERBUILD, INC. is duly incorporated under the law of the Commonwealth of Virginia;

That the date of its incorporation is December 22, 1983;

That the period of its duration is perpetual; and

That the corporation is in existence and in good standing in the Commonwealth of Virginia as of the date set forth below.

Nothing more is hereby certified.



*Signed and Sealed at Richmond on this Date:
December 19, 2016*

Joel H. Peck

Joel H. Peck, Clerk of the Commission

Construction Bonds Inc.

October 16, 2017

Fuog/Interbuild, Inc.
Mr. John Fuog
P.O. Box 237
Purcellville, VA 20134

RE: County of Fluvanna, VA

Dear John,

Please include this with your proposal.

Construction Bonds, Inc. currently handles the bonding needs of *Fuog/Interbuild, Inc.* *Fuog/Interbuild, Inc.* has been an active client of Construction Bonds, Inc. since 2003. The contractor has always been efficient at providing any and all documentation required by surety. We look forward to continuing our relationship far into the future.

Fuog/Interbuild, Inc. is currently set up for bonding through *Travelers Casualty and Surety Company of America* is a Treasury-listed company. We have considered bid, performance and payment bonds in excess of \$2,000,000 and would be glad to consider a projects in the referenced range should they be awarded a contract.

While we know of no reason at this time that would prevent us from issuing required payment and performance bonds, you understand that any arrangement for the bid or final bond(s) is a matter between the contractor and the respective surety and is subject to their normal underwriting standards, practices and conditions. These include, but are not limited to, the following: (1) client meeting all underwriting criteria at the time the bond(s) are requested, (2) review of bid or contract documents, (3) evidence of adequate financing, (4) bid spread of 10% or less, and (5) requests for final bonds are made prior to the commencement of work.

Please feel free to contact us if you have any questions.

Sincerely,

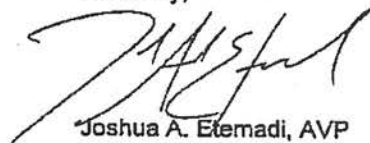

Joshua A. Etemadi, AVP
Attorney-in-Fact

HIGHLIGHTS FROM 2016

est. 1981

Serving our customers over 36 years.



22 Stall Barn, Upper Marlboro, MD
Winner of the NFBA Building of the Year (5,000 sq. ft. and up)

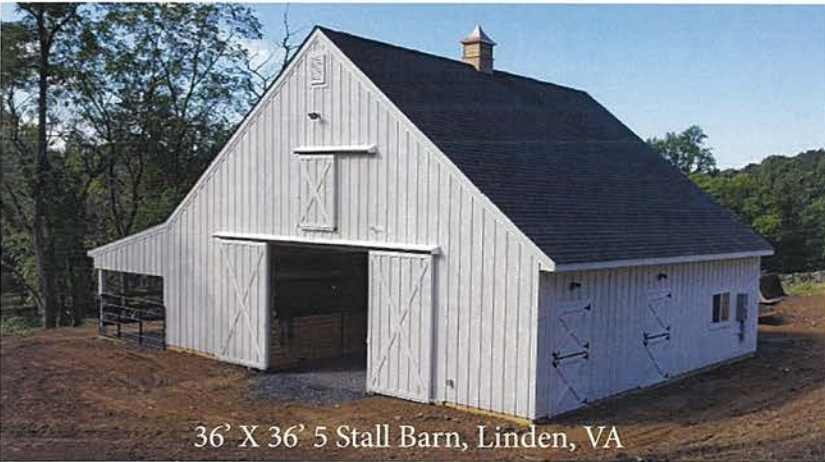

36' X 36' 5 Stall Barn, Linden, VA



80' X 150' Indoor Arena, Waterford, VA

Post Frame Construction (Pole Buildings)

Horse Barns, Arenas, Garages, Hobby Barns, Wineries

Pre Engineered Metal Buildings

Authorized Butler Builder, Commercial,
Industrial, Agricultural

Site work

Excavation, Roads, Outdoor Arenas, Water, Sewer,
Ponds, Storm Sewer, Commercial, Residential,
Industrial, Agricultural

Fuog/InterBuild, Inc.

P.O. Box 237
Purcellville, VA 20134

www.FuogInterBuildinc.com

Sales@FuogInterBuildinc.com

540-338-2306 800-432-3864

Fax: 540-338-3015



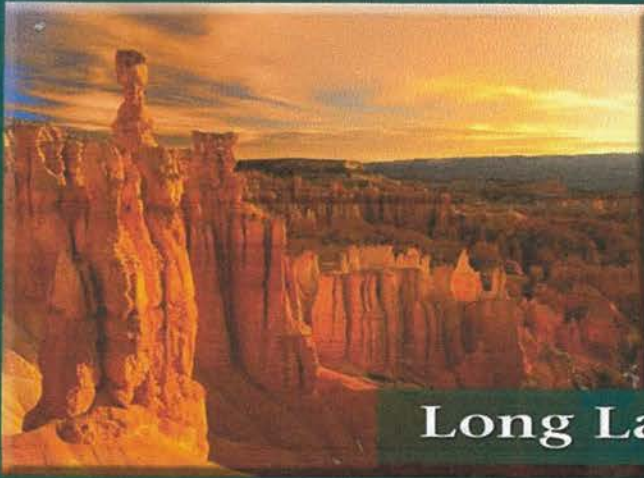

Long Lasting



Vibrant

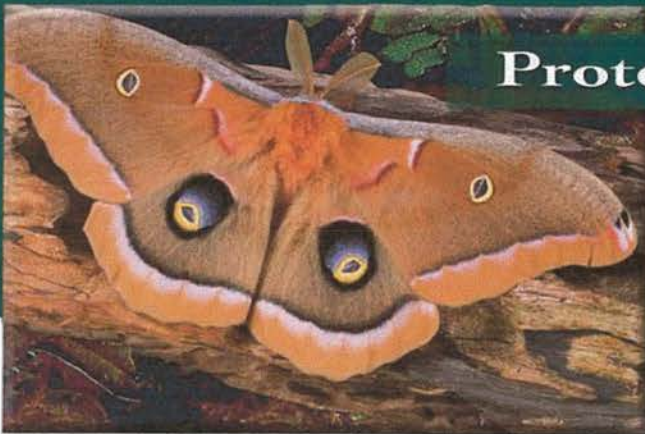

Protective

Color BY NATURE

DITTO
Kynar 500®

Color by

Metal Roof & Wall Panels



McElroy Metal has been a leading manufacturer of metal roofing and siding for over 50 years. McElroy's long-standing reputation of providing high quality products and services has been earned through product innovation and dedication to customers. In keeping with that tradition, McElroy's entire line of painted wall and roof panels is available with a 70% PVDF (fluoropolymer) based paint system. Chemically similar to Teflon®, 70% PVDF based coatings offer the most superior performance available in the industry today. This brochure will answer many questions you may have about paint systems, as well as describe and illustrate some of the extensive testing that has been conducted comparing the performance of 70% PVDF coatings versus other commonly used systems.

What is a 70% PVDF coating?

70% PVDF (fluoropolymer) resins are used to manufacture high quality paint. Only two 70% PVDF resins are manufactured in the U.S. marketplace, Kynar 500® and Hylar 5000™. These two resins are used by The Valspar Corporation to make Fluoron®, McElroy's 70% PVDF coating of choice. The 70% refers to the fact that 70% of the paint's resin is made of Kynar 500® or Hylar 5000™.

What are some of the benefits of Kynar 500® coatings?

Unsurpassed resistance to chalking and fading, combined with ease of maintenance and chemical resistance, are a few of the many benefits. Kynar 500 coatings are highly resistant to chalking and fading due to the inherent nature of the resin's chemistry. When the PVDF resins are combined with other durable ingredients, such as ceramic pigmentation, the resulting paint's resistance to chalking and fading is unequaled. In addition, Kynar 500 coatings are non-attractant to dirt and other airborne particles. If cleaning is necessary, just like your Teflon coated pan, your panels will clean up easily with a little soap and water. Kynar 500 coatings are also virtually unaffected by incidental contact with most chemicals or air pollution.

What are other commonly used resin systems in this industry?

Paints using resins made of polyester and siliconized polyester are commonly used in the metal construction industry. In test after test, Kynar 500 resin based paint systems outperform all other resin systems.

Why should I specify a Kynar 500® coating for my building?

Adding a new roof or building to your property is a major financial investment, and you want it to be both functional and attractive for many years to come. Nothing makes a bigger impact or says "quality maintenance" of your property like a sparkling new paint finish. When you specify McElroy panels with a Kynar 500 paint system, you are ensured of a "just painted" freshness year-after-year.

How do I know Kynar 500® systems are better?

Kynar 500 systems are the coating of choice for building owners and architects worldwide. In fact, over 10 billion square feet of building products coated with Kynar 500 systems can be found on skyscrapers, airports, shopping malls, and other structures all throughout the world.





Both Kynar 500® and Siliconized Polyester panels were install on this Louisiana residence.

On day one, colors were identical. Photo taken less than (8) years later shows fading and chalking of the lighter Siliconized Polyester panels. Note, no fade or chalking of the darker Kynar 500 panels.

The building on the right had signs removed from the metal panels. The different colors that are evident are directly attributed to the level of chalk and fade due to exposure to nature's elements.



Are Kynar 500® finishes new?

No. Kynar 500 finishes have been manufactured for over 40 years. Historically, these finishes have been primarily used in the high-rise and architectural market place. Although PVDF paint technology is not new, the standardized use of these systems in the metal clad construction market is relatively new. McElroy Metal is the first metal components company to offer PVDF coatings on all products as a standard inventoried item.

How do I ensure that a Kynar 500® coating is used on my building?

Specify to your builder or supplier that you will only accept metal panels coated with a Kynar 500 finish on your building. Contact the McElroy office nearest you to find a McElroy supplier or contractor in your area.

Are Kynar 500® coatings important for all colors?

Yes. However, the damaging effects of nature's elements are more visible on darker colors. The darker the color, the more obvious chalking and fading are. As white metal panels fade and chalk, the weathered appearance of the panel is still white. However, the fading and chalking will dull the appearance of the panel.

Aside from coatings, what else is important in choosing a metal panel?

The metal substrate is an important factor in regards to panel longevity and performance. The most commonly used substrates in the metal roofing and the siding industry are galvanized and GALVALUME®. Galvanized substrates utilize zinc as a protective coating, while GALVALUME® uses an alloy of zinc plus aluminum. For most applications, GALVALUME® is the preferred substrate due to superior performance history.

Fluropon® is a registered trademark of The Valspar Corporation.

Teflon® is a registered trademark of DuPont.

Kynar 500® is a registered trademark of Arkema.

Hylar 5000® is a trademark of Solvay Solexis.

GALVALUME® is a registered trademark of BIEC International.



Chalking

Chalking occurs when environmental conditions cause degradation of the resin. Contributors to the degradation include: ultraviolet rays from the sun, acid rain, and pollution. As the resin degrades, it takes on a white appearance, commonly called chalk. Kynar 500® finishes offer the strongest resistance to chalking of any paint system on the market.

Fading

Fading occurs when the environment attacks the pigment portion of the paint system. As a metal panel is continually exposed to the elements, it will lose more and more of its original color. Valspar's Kynar 500 coating, fluropon,

incorporates the highest quality ceramic pigments available for proven resistance against the fading phenomena.

Case Study

Two panels with McElroy Tudor Brown Kynar 500 coating were included in a shipment of Tudor Brown Max-Rib panels with Siliconized Polyester coating bound for a Belpre, Ohio job-site. After 5 years of exposure to Ohio weather, note the fading and chalking of the siliconized polyester panels compared to the "look-like-new" Kynar 500 (PVDF) panels.



Installation Date: June, 1994
Photo Date: April, 2000

Video

Take the mystery out of purchasing metal panels. Visit: www.mcelroymetal.com/university to view an educational video about metal panel substrates and coatings.



1500 Hamilton Rd. • Bossier City, LA 71111
www.mcelroymetal.com • info@mcelroymetal.com

MANUFACTURING LOCATIONS

ADELANTO, CA	ASHBURN, GA	BOSSIER CITY, LA	CLINTON, IL
HOUSTON, TX	LEWISPORT, KY	MARSHALL, MI	MAUSTON, WI
MERKEL, TX	PEACHTREE CITY, GA	SUNNYVALE, TX	WINCHESTER, VA



Alexandria, LA	Baltimore, MD	Bossier City, LA	Chesapeake, VA
Clinton, IL	Diamond, MO	Fenton, MO	Ft. Walton Beach, FL
Garland, TX	Houston, TX	Indianapolis, IN	Lewisport, KY
McFarland, WI	Nashville, TN	North Little Rock, AR	Pearl, MS
Richland Hills, TX	Sacramento, CA	Savannah, GA	
Union City, GA	West Columbia, SC	Winchester, VA	

McELROY METAL, INC.
KYNAR 500® (PVDF)
COATING SYSTEM LIMITED WARRANTY
APPLICABLE PRODUCTS: ALL MCELROY KYNAR 500® (PVDF) COATED PRODUCTS

McElroy Metal, Inc. ("McElroy") warrants to the purchaser of McElroy panels using Galvalume, galvanized G90 or aluminum substrates with standard KYNAR 500® (PVDF) or Hylar 5000® coating systems that when used in exterior applications the coating system will meet the following standards. For warranty terms on special and/or non standard colors, please contact a McElroy representative.

1. For a period of 40 years from the date of shipment, the coating system will not crack, check or peel (lose adhesion).
2. For a period of 30 years from the date of shipment, the coating system will not chalk in excess of numerical rating nine (9) for sidewall applications and numerical rating eight (8) for roof applications when measured in accordance with ASTM D-4214 method A procedures.
3. For a period of 30 years from the date of shipment, the coating system will not change color (fade) more than four (4) ΔE Hunter units for sidewall applications and five (5) ΔE Hunter units for roof applications when tested in accordance with ASTM D-2244 method A procedures. Color change shall be measured on an exposed painted surface that has been cleaned of surface soils and chalk, and the corresponding values measured on the original or unexposed surface. It is understood that fading or color changes may not be uniform, if the surfaces are not equally exposed to the sun and elements.

Orange, Casco Orange, Safety Orange and Brite Red are warranted under the same testing methods and limitations as indicated on this warranty, but have special numerical ratings as indicated below:

1. For a period of 20 years from the date of shipment, the coating system will not crack, check or peel (lose adhesion).
2. For a period of 10 years from the date of shipment, the coating system will not chalk in excess of numerical rating eight (8) for sidewall and roof applications.
3. For a period of 10 years from the date of shipment, the coating system will not change color (fade) more than five (5) ΔE Hunter units for sidewall and roof applications.

McElroy Metal also warrants that for a period of fifteen (15) years, panels coated with KYNAR 500® (PVDF) or Hylar 5000®, when installed in vertical or non-vertical applications (min 3:12 slope) will not exhibit accumulation of red rust greater than 3/4" at any one interior point of the panel. This provision shall not apply to any accumulation of red rust which occurs within 3/4" of breaks of discontinuities in the surface, such as panel edges (factory or field cut) or metal penetrations (such as fasteners) at any time after application of pre-treatment and paint systems.

Subject to the conditions, limitations and exclusions set forth below. If any panels fail to comply with the warranty specifications set forth above, McElroy agrees to repair, repaint or replace such panels, at its sole cost and expense. McElroy shall have the sole option of repairing, repainting or replacing the panels and may contract for such work. Any repaired, repainted or replaced panel shall be covered by this limited warranty, but only for the remainder of the period applicable to the panel originally purchased. McElroy's liability under this warranty shall be limited to the cost of labor and materials reasonably necessary to repair, repaint or replace the panels that do not meet the above specifications. All claims filed under this warranty must be presented in writing by the purchaser to McElroy during the warranty period and not more than 30 days after discovery by the purchaser of the problem for which the claim is made. All claims must reference McElroy's invoice number and be either hand delivered or sent by registered or certified mail to McElroy Metal at 1500 Hamilton Road, Bossier City, Louisiana 71111.

THIS WARRANTY SHALL BE SUBJECT TO THE FOLLOWING CONDITIONS, LIMITATIONS AND EXCLUSIONS:

- A. This warranty covers only panels erected in the continental United States, Alaska and Canada, which are exposed to normal weather and atmospheric conditions.
- B. This warranty is for the benefit of the original purchaser only and is not transferable or assignable.
- C. In determining whether the panel meets the specifications set forth above, color change shall be measured on an exposed painted surface that has been cleaned of surface soils and chalk per ASTM D 2244 method A procedures. McElroy does not warrant that color changes will be uniform.
- D. This warranty is null and void for any material that is subjected to salt spray or installed on property 1,500 feet or fewer from a salt water environment.
- E. This warranty does not apply to defects or failures which arise out of any of the following:
 - (1) the formation of rust on the panel edges;

- (2) acts of God, falling objects, external forces, explosions, fire, riots, civil commotions, acts of war, radiation, harmful gases, harmful fumes, salt atmosphere or standing water due to failure to provide adequate slope and drainage;
 - (3) failure to properly insulate panels from copper, lead, and other dissimilar metals, contact with damp insulation, debris, soil, vegetation, animal waste, decaying materials, wet absorptive materials, concrete or other foreign or corrosive materials from contact with or in close proximity to the panel;
 - (4) use in manner not intended or improper storage or handling, including but not limited to damage from condensation on the panels attributable to improper handling; or
 - (5) failure of the metal substrate;
 - (6) minute fracturing which may occur in proper fabrication of the building parts;
 - (7) if panels are applied without protection over lumber which has been treated with preservatives or fire resistant materials, regardless whether such treatments are present with or without the knowledge of the buyer, the owner or any other party. This exclusion shall include, but is not limited to, lumber which has been treated with pentachlorophenol, chromated copperarsenated salts, creosote, fluochrome arsenate phenol, alkaline copper quaternary, or any similar treatment for fire and rot resistance. Protection of lumber as provided for in the exclusion shall be defined as any barrier that prevents the transfer of moisture and salts between the treated lumber and pre-finished metal panel;
 - (8) abnormal corrosive atmospheric conditions. This exclusion includes, but is not limited to, contamination from external sources such as manufactured chemicals and salt spray, and internal contamination created by improper ventilation (design or operational defects) or improper housekeeping;
 - (9) discontinuities in the paint film as a result of damage during installation or use of the building e.g. scratches;
 - (10) design flaws that would result in moisture (water) or other foreign materials to accumulate resulting in excessive exposure to moisture or foreign material.
- F. McElroy shall have no obligations under this warranty unless and until McElroy receives payment in full for the materials furnished.
 - G. The supplier of the paint coating applied to McElroy panels and the applicator of the paint coating has made certain warranties to McElroy which are same (or substantially similar) to the warranties made by McElroy under this limited warranty. This limited warranty shall be of no further force or effect if such supplier, or its successors or assigns, can no longer perform its obligations under the coating system warranties made to McElroy.

THERE ARE NO OTHER GUARANTEES OR WARRANTIES, EXPRESSED OR IMPLIED, WHICH EXTEND BEYOND THE DESCRIPTION AS STATED HEREIN, INCLUDING ANY WARRANTIES OF MERCHANTABILITY OR FITNESS OF PURPOSE. McELROY METAL SHALL NOT BE RESPONSIBLE FOR ANY INDIRECT OR CONSEQUENTIAL DAMAGES (SUCH AS DAMAGES TO THE CONTENTS OR FURNISHINGS OF ANY BUILDING) OR ANY LOSS OF ANY KIND WHATSOEVER.

REV. 04/16
MM613



P.O. Box 237
Purcellville, VA 20134
540/338-2306
1-800-432-FUOG



COLOR SELECTOR



*BRITE WHITE IS SILICONIZED POLYESTER. REGAL WHITE IS KYNAR 500®
ALL COLORS ARE ENERGY STAR COMPLIANT.

Exhibit 3

DRAFT

STANDARD PERFORMANCE BOND FOR CONSTRUCTION CONTRACTS

KNOW ALL MEN BY THESE PRESENT:

That , _____the Contractor (“Principal”) whose principal place of business is located at _____ and _____ (“Surety”) are held and firmly bound unto the County of Fluvanna, Virginia, the Owner (“Obligee”) in the amount of Dollars (\$ _____), for the payment whereof Principal and Surety bind themselves, their heirs, executors, administrators, successors and assigns, jointly and severally, firmly by these presents.

WHEREAS, Principal has by written agreement dated the ___ day of _____, 20__ entered into a contract with Obligee for which contract (the “Contract”) is by reference expressly made a part hereof;

NOW THEREFORE, THE CONDITION OF THIS OBLIGATION is such that, if the Principal shall promptly and faithfully perform said Contract in strict conformity with the plans, specifications and conditions of the Contract, then this obligation shall be null and void; otherwise it shall remain in full force and effect.

Provided, that any alterations which may be made in the terms of the Contract, or in the Work to be done under it, or the giving by the Obligee of any extension of the time for the performance of the Contract, or any other alterations, extensions or forbearance on the part of either or both of the Obligee or the Principal to the other shall not in any way release the Principal and the Surety, or either of them, their heirs, executors, administrators, successors or assigns from their liability hereunder, notice to the Surety of any such alterations, extension, or forbearance being hereby waived.

No action shall be brought on this bond unless brought within one year after: (a) completion of the Contract and all Work thereunder, including expiration of all warranties and guarantees, or (b) discovery of the defect or breach of warranty or guarantee if the action be for such. The Surety represents to the Principal and to the Obligee that it is legally authorized to do business in the Commonwealth of Virginia. Exclusive venue and jurisdiction for any dispute arising hereunder shall be in the courts of the County of Fluvanna, Virginia.

Signed and sealed this ___ day of _____, 20__ .

Principal

Surety (must be signed by a Virginia Resident Agent of Surety)

By: _____

By: _____

Title: _____

Title: _____

Date: _____

Date: _____

Address: _____

Approved as to form:

Bond No.: _____

Fluvanna County Attorney

STANDARD LABOR AND MATERIAL PAYMENT BOND

KNOW ALL MEN BY THESE PRESENT:

That , _____ the Contractor (“Principal”) whose principal place of business is located at _____ and _____ (“Surety”) are held and firmly bound unto the County of Fluvanna, Virginia, the Owner (“Obligee”) in the amount of Dollars (\$ _____), for the payment whereof Principal and Surety bind themselves, their heirs, executors, administrators, successors and assigns, jointly and severally, firmly by these presents.

WHEREAS, Principal has by written agreement dated the ___ day of _____, 20__ entered into a contract with Obligee for which contract (the “Contract”) is by reference expressly made a part hereof;

NOW THEREFORE, THE CONDITION OF THIS OBLIGATION is such that, if the Principal shall promptly make payment to all claimants as hereinafter defined, for labor performed and material furnished in the prosecution of the Work provided for in the Contract, then this obligation shall be void; otherwise it shall remain in full force and effect, subject, however, to the following conditions.

The Principal and Surety, jointly and severally, hereby agree with Obligee as follows:

1. A claimant is defined as one having a direct contract with the Principal or with a subcontractor of the Principal for labor, material, or both for use in the performance of the Contract. A “subcontractor” of the Principal, for the purposes of this bond only, includes not only those subcontractors having a direct contractual relationship with the Principal, but also any other contractor who undertakes to participate in the Work which the Principal is to perform under the aforesaid Contract, whether there are one or more intervening subcontractors contractually positioned between it and the Principal (for example, a subcontractor). “Labor” and “material” shall include, but not be limited to, public utility services and reasonable rentals of equipment, but only for periods when the equipment rented is actually used at the work site.

2. Subject to the provisions of paragraph 3, any claimant who has performed labor or furnished material in accordance with the Contract documents in the prosecution of the Work provided in the Contract, who has not been paid in full therefor before the expiration of ninety (90) days after the day on which such claimant performed the last of such labor or furnished the last of such materials for which he claims payment, may bring an action on this bond to recover any amount due him for such labor or material, and may prosecute such action to final judgment and have execution on the judgment. The Obligee need not be a party to such action and shall not be liable for the payment of any costs, fees or expenses of any such suit.

3. Any claimant who has a direct contractual relationship with any subcontractor of the Principal from whom the Principal has not required a subcontractor payment bond, but who has no contractual relationship, express or implied, with the Principal, may bring an action on this bond only if he has given written notice to the Principal within one hundred eighty (180) days from the day on which the claimant performed the last of the labor or furnished the last of the

STANDARD LABOR AND MATERIAL PAYMENT BOND

materials for which he claims payment, stating with substantial accuracy the amount claimed and the name of the person for whom the Work was performed or to whom the material was furnished. Notice to the Principal shall be served by registered or certified mail, postage prepaid, in an envelope addressed to the Principal at any place where his office is regularly maintained for the transaction of business. Claims for sums withheld as retainages with respect to labor performed or materials furnished shall not be subject to the time limitations stated in this paragraph 3.

4. No suit or action shall be commenced hereunder by any claimant;

a. Unless brought within one year after the day on which the person bringing such action last performed labor or last furnished or supplied materials, it being understood, however, that if any limitation embodied in this bond is prohibited by any law controlling the construction hereof, the limitation embodied within this bond shall be deemed to be amended so as to be equal to the minimum period of limitation permitted by such law.

b. Other than in a Virginia court of competent jurisdiction and parties agree that exclusive venue and jurisdiction for any dispute arising hereunder shall be in the courts of the County of Fluvanna, Virginia.

5. The amount of this bond shall be reduced by and to the extent of any payment or payments made in good faith hereunder.

Signed and sealed this ___ day of _____, 20__ .

Principal

Surety (must be signed by a Virginia Resident Agent of Surety)

By: _____

By: _____

Title: _____

Title: _____

Date: _____

Date: _____

Address: _____

Approved as to form:

Bond No.: _____

Fluvanna County Attorney

FLUVANNA COUNTY BOARD OF SUPERVISORS AGENDA ITEM STAFF REPORT

TAB S

MEETING DATE:	November 15, 2017																																								
AGENDA TITLE:	FY17 to FY18 Carryover Requests																																								
MOTION(s):	<p>I move the Board of Supervisors [approve/deny/defer] the following carryover requests of FY17 unexpended budget lines from the listed departments to the FY18 Department Budget lines as specified and in the amounts listed:</p> <table border="1" style="width: 100%; border-collapse: collapse;"> <thead> <tr> <th style="text-align: left;"><u>Department</u></th> <th style="text-align: left;"><u>Budget Line</u></th> <th style="text-align: right;"><u>Amount</u></th> </tr> </thead> <tbody> <tr> <td>A. Clerk of Circuit Court</td> <td>Security and Disaster Recovery</td> <td style="text-align: right;">\$26,000</td> </tr> <tr> <td>B. Circuit Court Judge</td> <td>Security and Storage</td> <td style="text-align: right;">\$9,000</td> </tr> <tr> <td>C. Sheriff's Office</td> <td>CAD Training Overtime</td> <td style="text-align: right;">\$7,000</td> </tr> <tr> <td>D. Sheriff's Office</td> <td>Holiday & Discretionary Pay</td> <td style="text-align: right;">\$13,000</td> </tr> <tr> <td>E. Sheriff's Office</td> <td>Training for Mobile Devices</td> <td style="text-align: right;">\$2,137</td> </tr> <tr> <td>F. Sheriff's Office</td> <td>Police Supplies</td> <td style="text-align: right;">\$13,230</td> </tr> <tr> <td>G. Sheriff's Office</td> <td>Mobile Device Inv Services</td> <td style="text-align: right;">\$2,974</td> </tr> <tr> <td>H. Animal Control</td> <td>Emergency Vet Care</td> <td style="text-align: right;">\$1,140</td> </tr> <tr> <td>I. Animal Control</td> <td>Holiday & Discretionary Pay</td> <td style="text-align: right;">\$6,000</td> </tr> <tr> <td>J. E911</td> <td>CAD Training Overtime</td> <td style="text-align: right;">\$15,000</td> </tr> <tr> <td>K. E911</td> <td>Holiday and Discretionary Pay</td> <td style="text-align: right;">\$10,000</td> </tr> </tbody> </table> <p>with a total amount of \$_____ to be re-appropriated.</p>					<u>Department</u>	<u>Budget Line</u>	<u>Amount</u>	A. Clerk of Circuit Court	Security and Disaster Recovery	\$26,000	B. Circuit Court Judge	Security and Storage	\$9,000	C. Sheriff's Office	CAD Training Overtime	\$7,000	D. Sheriff's Office	Holiday & Discretionary Pay	\$13,000	E. Sheriff's Office	Training for Mobile Devices	\$2,137	F. Sheriff's Office	Police Supplies	\$13,230	G. Sheriff's Office	Mobile Device Inv Services	\$2,974	H. Animal Control	Emergency Vet Care	\$1,140	I. Animal Control	Holiday & Discretionary Pay	\$6,000	J. E911	CAD Training Overtime	\$15,000	K. E911	Holiday and Discretionary Pay	\$10,000
	<u>Department</u>	<u>Budget Line</u>	<u>Amount</u>																																						
A. Clerk of Circuit Court	Security and Disaster Recovery	\$26,000																																							
B. Circuit Court Judge	Security and Storage	\$9,000																																							
C. Sheriff's Office	CAD Training Overtime	\$7,000																																							
D. Sheriff's Office	Holiday & Discretionary Pay	\$13,000																																							
E. Sheriff's Office	Training for Mobile Devices	\$2,137																																							
F. Sheriff's Office	Police Supplies	\$13,230																																							
G. Sheriff's Office	Mobile Device Inv Services	\$2,974																																							
H. Animal Control	Emergency Vet Care	\$1,140																																							
I. Animal Control	Holiday & Discretionary Pay	\$6,000																																							
J. E911	CAD Training Overtime	\$15,000																																							
K. E911	Holiday and Discretionary Pay	\$10,000																																							
STRATEGIC INITIATIVE?	Yes	No	If yes, list initiative(s):																																						
		X																																							
AGENDA CATEGORY:	Public Hearing	Action Matter	Presentation	Consent Agenda	Other																																				
		X																																							
STAFF CONTACT(S):	Mary Anna Twisdale, Management Analyst																																								
PRESENTER(S):	Mary Anna Twisdale, Management Analyst Steve Nichols, County Administrator Captain Von Hill, Chief of Administrative Operations Tristana Treadway, Clerk of the Circuit Court																																								
RECOMMENDATION:																																									
TIMING:	Effective July 1, 2016																																								
DISCUSSION:	<p>Per Fluvanna County Financial Policies Section 1-10 (Re-appropriation):</p> <p><u>Had budget authority in FY17</u></p> <ol style="list-style-type: none"> 2. Initiative/Project was started in FY17, but was not able to be completed. <ul style="list-style-type: none"> - Meets existing policy. 3. Initiative/project not started in FY17 due to circumstances. 																																								

	<p style="text-align: center;">- Meets existing policy.</p> <p>No budget authority in FY17</p> <p>4. Requesting carryover of FY17 remaining funds to cover certain one-time special or capital projects that are not already approved/funded.</p> <p style="text-align: center;">- Does not meet existing policy.</p> <p>5. Requesting carryover of FY17 remaining funds for unanticipated operating expenses not included in the FY18 budget</p> <ul style="list-style-type: none"> - i.e., Not funded in FY18, but request/need has been identified; asking for unexpended FY17 dollars to cover that request/need (rather than wait until FY19 budget). - Does not meet existing policy. <p>Approval of the motion as stated above will allow the Finance Department to increase FY18 revenue and expenses by \$_____.</p>				
FISCAL IMPACT:	Approval of the motion as stated above will allow the Finance Department to increase FY18 revenue and expenditure budgets equally within the assigned funds.				
POLICY IMPACT:	N/A				
LEGISLATIVE HISTORY:	Financial Policies – Section 1-10 – BOS Approved September 1, 2010				
ENCLOSURES:	<ul style="list-style-type: none"> · YTD Budget Report for Requesting Departments · Office/Departmental Carryover Requests Forms 				
REVIEWS COMPLETED:	Legal	Finance	Purchasing	HR	Other
		X			

County of Fluvanna

Carryover Request FY17/18

Office/Department: Clerk of Circuit Court

General Ledger Account Title	FY17 Org Code	FY17 Object Code	FY18 Org Code (If Different)	FY18 Object Code (If Different)	Amount Requested	Justification: <u>Please answer all three questions.</u> Why should these funds be carried forward? Why was the project not completed within FY17? If this request is denied, what impact will it have on this Office/Department's ability to function efficiently?
1 Various Operating Budget Lines	10023000	Var.		403100	\$ 7,000.00	These funds should be carried forward in support of on-going projects to address security upgrades and disaster recovery plans. Timing constraints and coordination of projects and the necessary HVAC upgrades as requested by public works have played a significant role in several projects remaining in their infancy. If denied, FY18 funding will be deficient to carry out projects to address and implement necessary upgrades to ensure county safety, security and abidance of state policies.
2				408102	\$ 19,000.00	
3						
4						
5						
6						
Office/Department: Clerk of Circuit Court					Total Carryover Amount Requested: \$ 26,000.00	



11/07/2017 14:43
5311mtwi

COUNTY OF FLUVANNA
YEAR-TO-DATE BUDGET REPORT

P 1
glytddb

FOR 2017 12

ACCOUNTS FOR: 100	GENERAL FUND	ORIGINAL APPROP	REVISED BUDGET	YTD EXPENDED	MTD EXPENDED	ENCUMBRANCES	AVAILABLE BUDGET	PCT USED
230 CLERK OF THE CIRCUIT COURT								
<u>10023000</u>	<u>401100</u>	<u>SAL & WAGE</u>	381,817	381,817	374,342.63	45,035.55	.00	7,474.37 98.0%
<u>10023000</u>	<u>401115</u>	<u>JURORWITNS</u>	0	0	.00	.00	.00	.00 .0%
<u>10023000</u>	<u>401300</u>	<u>PT SAL/WAG</u>	0	0	.00	.00	.00	.00 .0%
<u>10023000</u>	<u>401310</u>	<u>OT PAY</u>	2,000	2,000	657.93	.00	1,342.07	32.9%
<u>10023000</u>	<u>402100</u>	<u>FICA</u>	29,209	29,209	26,653.45	3,412.36	2,555.55	91.3%
<u>10023000</u>	<u>402210</u>	<u>VRS</u>	40,396	30,138	30,022.68	2,715.88	115.32	99.6%
<u>10023000</u>	<u>402250</u>	<u>DISABILITY</u>	185	185	1,060.02	92.88	-875.02	573.0%*
<u>10023000</u>	<u>402300</u>	<u>MEDINS</u>	66,120	67,593	58,517.50	.00	9,075.50	86.6%
<u>10023000</u>	<u>402400</u>	<u>GRPLIFE</u>	4,544	4,607	4,727.77	426.08	-120.77	102.6%*
<u>10023000</u>	<u>402600</u>	<u>UNEMPL</u>	0	0	6,934.58	2,237.52	-6,934.58	100.0%*
<u>10023000</u>	<u>402700</u>	<u>WORKCOMP</u>	371	246	245.83	.00	.00	100.0%
<u>10023000</u>	<u>403100</u>	<u>PROFSVCS</u>	36,000	54,441	46,663.02	14,696.17	7,777.98	85.7%
<u>10023000</u>	<u>403140</u>	<u>TFND TECHTRUST</u>	7,000	6,932	6,932.40	.00	.00	100.0%
<u>10023000</u>	<u>403150</u>	<u>RECPR RECRDPRSV</u>	14,000	31,900	31,900.00	.00	.00	100.0%
<u>10023000</u>	<u>403300</u>	<u>CONTRSVC</u>	1,500	1,390	827.84	124.23	562.16	59.6%
<u>10023000</u>	<u>403310</u>	<u>REP/MAINT</u>	500	500	175.00	.00	325.00	35.0%
<u>10023000</u>	<u>403320</u>	<u>MAINTCONT</u>	1,200	1,310	1,310.00	.00	.00	100.0%
<u>10023000</u>	<u>403500</u>	<u>PRINTING</u>	3,000	3,000	3,000.00	974.77	.00	100.0%
<u>10023000</u>	<u>403600</u>	<u>ADVERT</u>	0	0	.00	.00	.00	.0%
<u>10023000</u>	<u>405210</u>	<u>POSTAL</u>	5,000	5,000	5,000.00	1,000.00	.00	100.0%
<u>10023000</u>	<u>405230</u>	<u>TELECOMM</u>	1,500	800	513.91	77.54	286.09	64.2%
<u>10023000</u>	<u>405410</u>	<u>LEASERENT</u>	3,300	3,535	3,531.39	419.91	3.61	99.9%
<u>10023000</u>	<u>405510</u>	<u>MILEAGE</u>	750	709	395.46	211.86	313.39	55.8%
<u>10023000</u>	<u>405540</u>	<u>CONVEDUC</u>	1,000	2,075	1,300.00	250.00	775.00	62.7%
<u>10023000</u>	<u>405810</u>	<u>DUES</u>	400	495	495.00	.00	.00	100.0%
<u>10023000</u>	<u>405999</u>	<u>PENALTIES</u>	0	0	.00	.00	.00	.0%
<u>10023000</u>	<u>406001</u>	<u>OFFSUPL</u>	7,000	6,820	5,546.84	932.07	1,273.16	81.3%
<u>10023000</u>	<u>406012</u>	<u>BOOKS</u>	100	9	8.75	.00	.00	100.0%
<u>10023000</u>	<u>406014</u>	<u>OTHEROPER</u>	0	0	.00	.00	.00	.0%
<u>10023000</u>	<u>408102</u>	<u>FURN/FIX</u>	1,000	11,212	852.27	854.68	10,359.73	7.6%
<u>10023000</u>	<u>408107</u>	<u>EDPEQUIP</u>	2,500	2,500	.00	.00	2,500.00	.0%
<u>10023000</u>	<u>408108</u>	<u>LAND</u>	0	0	.00	.00	.00	.0%
<u>10023000</u>	<u>408109</u>	<u>BUILDING</u>	0	0	.00	.00	.00	.0%
TOTAL CLERK OF THE CIRCUIT COURT			610,392	648,423	611,614.27	73,461.50	.00	36,808.56 94.3%
TOTAL GENERAL FUND			610,392	648,423	611,614.27	73,461.50	.00	36,808.56 94.3%
TOTAL EXPENSES			610,392	648,423	611,614.27	73,461.50	.00	36,808.56



11/07/2017 14:43
5311mtwi

COUNTY OF FLUVANNA
YEAR-TO-DATE BUDGET REPORT

P 2
glytdbud

FOR 2017 12

	ORIGINAL APPROP	REVISED BUDGET	YTD EXPENDED	MTD EXPENDED	ENCUMBRANCES	AVAILABLE BUDGET	PCT USED
GRAND TOTAL	610,392	648,423	611,614.27	73,461.50	.00	36,808.56	94.3%

** END OF REPORT - Generated by Mary Anna Twisdale **

County of Fluvanna

Carryover Request FY17/18

Office/Department: Cir. Court Judge's Budget

General Ledger Account Title	FY17 Org Code	FY17 Object Code	FY18 Org Code (If Different)	FY18 Object Code (If Different)	Amount Requested	Justification: <u>Please answer all three questions.</u> Why should these funds be carried forward? Why was the project not completed within FY17? If this request is denied, what impact will it have on this Office/Department's ability to function efficiently?
1 Various Operating Budget Lines	10023500			408102	\$ 9,000.00	These funds should be carried forward to implement progressive necessary changes which have become evident this year. The audio system in the court has become unreliable from years of use and mistreatment. Security risks need to be minimized.
2						The issues have only recently become evident, so time constraints have impacted completion. Court cannot effectively function without these necessary audio and security improvements.
3						
4						
5						
6						
Office/Department: Cir. Court Judge's Budget					Total Carryover Amount Requested: \$ 9,000.00	



11/07/2017 14:43
5311mtwi

COUNTY OF FLUVANNA
YEAR-TO-DATE BUDGET REPORT

P 1
glytdbud

FOR 2017 12

ACCOUNTS FOR: 100 GENERAL FUND	ORIGINAL APPROP	REVISED BUDGET	YTD EXPENDED	MTD EXPENDED	ENCUMBRANCES	AVAILABLE BUDGET	PCT USED
235 CIRCUIT COURT JUDGE							
10023500 401115 JURORWITNS	10,800	10,800	1,710.00	.00	.00	9,090.00	15.8%
10023500 401116 JURYCOMMIS	180	180	180.00	.00	.00	.00	100.0%
10023500 401117 CIVILJUROR	4,500	4,500	2,220.00	.00	.00	2,280.00	49.3%
10023500 401118 GRNDJUROR	1,260	1,260	1,080.00	150.00	.00	180.00	85.7%
10023500 401119 WITNESSFEE	1,500	1,500	334.86	.00	.00	1,165.14	22.3%
10023500 401120 CAATTYFEES	500	500	.00	.00	.00	500.00	.0%
10023500 401300 PT SAL/WAG	0	0	.00	.00	.00	.00	.0%
10023500 403100 PROFSVCS	28,500	28,500	19,494.00	16,705.00	.00	9,006.00	68.4%
10023500 403320 MAINTCONT	0	0	.00	.00	.00	.00	.0%
10023500 405230 TELECOMM	450	450	144.49	19.00	.00	305.51	32.1%
10023500 405810 DUES	150	150	.00	.00	.00	150.00	.0%
10023500 405999 PENALTIES	0	0	.00	.00	.00	.00	.0%
10023500 406001 OFFSUPL	750	750	730.56	194.48	.00	19.44	97.4%
10023500 406014 OTHEROPER	0	0	.00	.00	.00	.00	.0%
10023500 408102 FURN/FIX	6,000	13,862	9,408.25	6,450.00	.00	4,453.75	67.9%
10023500 408107 EDPEQUIP	2,500	2,500	491.58	350.00	.00	2,008.42	19.7%
TOTAL CIRCUIT COURT JUDGE	57,090	64,952	35,793.74	23,868.48	.00	29,158.26	55.1%
TOTAL GENERAL FUND	57,090	64,952	35,793.74	23,868.48	.00	29,158.26	55.1%
TOTAL EXPENSES	57,090	64,952	35,793.74	23,868.48	.00	29,158.26	



11/07/2017 14:43
5311mtwi

COUNTY OF FLUVANNA
YEAR-TO-DATE BUDGET REPORT

P 2
glytbdud

FOR 2017 12

	ORIGINAL APPROP	REVISED BUDGET	YTD EXPENDED	MTD EXPENDED	ENCUMBRANCES	AVAILABLE BUDGET	PCT USED
GRAND TOTAL	57,090	64,952	35,793.74	23,868.48	.00	29,158.26	55.1%

** END OF REPORT - Generated by Mary Anna Twisdale **

County of Fluvanna

Carryover Request FY17/18

Office/Department: Sheriff's Office

General Ledger Account Title	FY17 Org Code	FY17 Object Code	FY18 Org Code (If Different)	FY18 Object Code (If Different)	Amount Requested	Please answer all three questions. Why should these funds be carried forward? Justification: Why was the project not completed within FY17? If this request is denied, what impact will it have on this Office/Department's ability to function efficiently?
1 Overtime Pay	10031000	401310			\$ 7,000.00	The new CAD implementation schedule requires a minimum of 24hr of training for each Deputy; training will occur during nonscheduled work hours. The 24 hr training was a mandate by Spillman Technologies. Current FY-18 overtime line will not sufficiently cover the cost of training for this new CAD system.
2 Holiday & Disc.	10031000	401320			\$ 13,000.00	The H&D line has consistently been insufficiently funded for the last 5 years, in FY-17 we were over budget by \$13,701; duringFY-17 we used very little discretionary time due to the absance of severe weather. If not funded this line will continue to operate in unfavorable budget variance.
3 Conv & Edu	10031000	405530			\$ 2,137.00	Application for the Federal Law Enforcement Training program for Mobile Device Investigations, was made in early 2017, but was not approved by the federal government until after the FY-18 budget began. Travel, lodging and meals were not provided, we did receive over \$20,000 in equipment such as mobile device extraction tools, a computer and a variety of software products used to extract information from mobile devices. If not funded this line will be in unfavorable budget variance at end of FY-18. Training for FY-18 has already been planned for the amount we requested in FY-18 budget.
4 Police Supplies	10031000	406009			\$ 13,230.00	In light of occurrences in the U.S. related to LEO and crowd control, we would like to purchase 34 helmets with face shields, 10 new gas masks and 40 updated filters for our gas masks. We currently have 12 old military helmets without shields and 24 gas masks with expired filters. If denied we will submit this request for additional equipment during the FY-19 budget process.
5 Inv Services	10031000	403190			\$ 2,974.00	This request is to assure the proper equipment and techniques are deployed going forward with the Mobile Device Investigations. The requested items to be purchased could not have been budgeted for FY-18, because they would have been useless without the now completed training and examination equipment. If not funded we can not properly conduct the Mobil Device Investigations.
6						

Office/Department: Sheriff's Office

Total Carryover Amount Requested: \$ 38,341.00



11/07/2017 14:44
5311mtwi

COUNTY OF FLUVANNA
YEAR-TO-DATE BUDGET REPORT

P 1
glytddbud

FOR 2017 12

ACCOUNTS FOR: 100	GENERAL FUND	ORIGINAL APPROP	REVISED BUDGET	YTD EXPENDED	MTD EXPENDED	ENCUMBRANCES	AVAILABLE BUDGET	PCT USED
310 SHERIFF								
10031000	401100	1,612,361	1,603,710	1,569,402.43	179,578.77	.00	34,307.13	97.9%
10031000	401300	41,739	43,657	41,392.40	5,041.26	.00	2,264.60	94.8%
10031000	401310	50,000	50,000	40,541.28	9,935.82	.00	9,458.72	81.1%
10031000	401320	44,000	44,000	57,701.81	6,378.20	.00	-13,701.81	131.1%*
10031000	401325	30,000	30,000	31,830.00	4,680.00	.00	-1,830.00	106.1%*
10031000	401331	0	0	.00	.00	.00	.00	.0%
10031000	401332	0	0	.00	.00	.00	.00	.0%
10031000	401333	0	0	.00	.00	.00	.00	.0%
10031000	401334	0	0	.00	.00	.00	.00	.0%
10031000	402100	121,314	121,461	127,130.90	15,747.28	.00	-5,669.90	104.7%*
10031000	402210	163,363	131,242	122,731.67	10,511.06	.00	8,510.33	93.5%
10031000	402250	0	0	39.44	.00	.00	-39.44	100.0%*
10031000	402300	158,913	239,216	213,663.81	.00	.00	25,552.19	89.3%
10031000	402400	18,374	20,062	19,419.75	1,699.56	.00	642.25	96.8%
10031000	402600	0	0	-401.75	.00	.00	401.75	100.0%
10031000	402700	25,477	30,116	33,038.28	2,922.00	.00	-2,922.00	109.7%*
10031000	402750	10,642	10,642	11,447.00	.00	.00	-805.00	107.6%*
10031000	402810	2,800	2,800	2,800.00	700.00	.00	.00	100.0%
10031000	402830	0	0	.00	.00	.00	.00	.0%
10031000	403100	746	746	1,169.00	2,150.18	.00	-423.00	156.7%*
10031000	403164	0	0	.00	.00	.00	.00	.0%
10031000	403190	0	4,679	5,101.39	1,730.49	.00	-422.65	109.0%*
10031000	403300	2,000	2,000	1,185.80	.00	.00	814.20	59.3%
10031000	403310	3,200	3,200	234.90	124.84	.00	2,965.10	7.3%
10031000	403315	25,300	36,791	42,357.92	17,290.77	.00	-5,566.93	115.1%*
10031000	403320	22,138	22,138	13,397.53	2,003.39	.00	8,740.47	60.5%*
10031000	403600	1,000	1,000	63.00	.00	.00	937.00	6.3%
10031000	405210	2,000	2,000	1,511.41	528.28	.00	488.59	75.6%
10031000	405230	39,559	39,559	44,473.19	4,946.80	.00	-4,914.19	112.4%*
10031000	405305	21,000	21,000	20,509.76	.00	.00	490.24	97.7%
10031000	405310	0	0	1,000.00	.00	.00	-1,000.00	100.0%*
10031000	405410	4,215	4,215	4,485.33	570.90	.00	-270.33	106.4%*
10031000	405510	0	0	.00	.00	.00	.00	.0%
10031000	405530	5,000	5,000	9,451.58	1,121.83	.00	-4,451.58	189.0%*
10031000	405540	37,200	37,200	37,753.30	250.00	.00	-553.30	101.5%*
10031000	405550	1,000	1,000	20.73	.00	.00	979.27	2.1%
10031000	405810	2,200	2,200	457.00	115.00	.00	1,743.00	20.8%
10031000	405999	0	0	.00	.00	.00	.00	.0%
10031000	406001	8,500	13,079	9,573.39	4,611.36	.00	3,506.06	73.2%
10031000	406002	0	0	24.06	.00	.00	-24.06	100.0%*



11/07/2017 14:44
5311mtwi

COUNTY OF FLUVANNA
YEAR-TO-DATE BUDGET REPORT

P 2
glytdbud

FOR 2017 12

ACCOUNTS FOR: 100 GENERAL FUND	ORIGINAL APPROP	REVISED BUDGET	YTD EXPENDED	MTD EXPENDED	ENCUMBRANCES	AVAILABLE BUDGET	PCT USED
<u>10031000 406003 AGRICSUPL</u>	0	0	.00	.00	.00	.00	.0%
<u>10031000 406008 VEHFUEL</u>	60,000	60,000	51,796.58	9,208.72	.00	8,203.42	86.3%
<u>10031000 406009 VEHSUPL</u>	21,050	24,750	25,305.74	8,448.07	.00	-555.74	102.2%*
<u>10031000 406010 POLICESUPL</u>	22,850	23,654	22,169.73	6,617.15	.00	1,484.76	93.7%
<u>10031000 406011 UNIFORMS</u>	10,900	10,900	10,360.00	7,797.82	.00	540.00	95.0%
<u>10031000 406011 BPVST UNIFORMS</u>	2,638	2,638	6,234.10	.00	.00	-3,596.10	236.3%*
<u>10031000 406014 OTHEROPER</u>	1,000	1,000	828.93	18.71	.00	171.07	82.9%
<u>10031000 406014 16VOL OTHEROPER</u>	0	1,610	1,931.96	.00	.00	-321.96	120.0%*
<u>10031000 408101 MACHEQUIP</u>	2,500	2,500	2,419.39	2,373.89	.00	80.61	96.8%
<u>10031000 408102 FURN/FIX</u>	1,500	1,500	1,666.80	1,666.80	.00	-166.80	111.1%*
<u>10031000 408103 COMMEQUIP</u>	2,000	2,000	596.75	.00	.00	1,403.25	29.8%
<u>10031000 408105 VEHICLE</u>	0	0	.00	.00	.00	.00	.0%
<u>10031000 408109 BUILDING</u>	0	0	.00	.00	.00	.00	.0%
TOTAL SHERIFF	2,578,479	2,653,266	2,586,816.29	308,768.95	.00	66,449.22	97.5%
TOTAL GENERAL FUND	2,578,479	2,653,266	2,586,816.29	308,768.95	.00	66,449.22	97.5%
TOTAL EXPENSES	2,578,479	2,653,266	2,586,816.29	308,768.95	.00	66,449.22	



11/07/2017 14:44
5311mtwi

COUNTY OF FLUVANNA
YEAR-TO-DATE BUDGET REPORT

P 3
glytdbud

FOR 2017 12

	ORIGINAL APPROP	REVISED BUDGET	YTD EXPENDED	MTD EXPENDED	ENCUMBRANCES	AVAILABLE BUDGET	PCT USED
GRAND TOTAL	2,578,479	2,653,266	2,586,816.29	308,768.95	.00	66,449.22	97.5%

** END OF REPORT - Generated by Mary Anna Twisdale **

County of Fluvanna

Carryover Request FY17/18

Office/Department: Fluvanna Sheriff's ACO

General Ledger Account Title	FY17 Org Code	FY17 Object Code	FY18 Org Code (If Different)	FY18 Object Code (If Different)	Amount Requested	Justification: <u>Please answer all three questions.</u> Why should these funds be carried forward? Why was the project not completed within FY17? If this request is denied, what impact will it have on this Office/Department's ability to function efficiently?
1 Holiday & Disc.	10035000	401320			\$ 6,000.00	Budget is not aligned with Expenses. Holiday and Discretionary Funds were not funded in the FY18 Budget by the County Administration. ACO deputies are part of the Patrol Division, they are required to work Holiday's. If not funded this budget line will continue operating in unfavorable budget variance.
2 Prof Services	10035000	40310			\$ 1,140.00	Professional Services expense line was not sufficiently funded, we are currently over budget in this line, which covers emergency veterinary care not covered under the new SPCA contract for FY18. If not funded this budget line will continue operating in an unfavorable budget variance.
3						
4						
5						
6						
Office/Department: Fluvanna Sheriff's ACO					Total Carryover Amount Requested: \$ 7,140.00	



11/07/2017 14:45
5311mtwi

COUNTY OF FLUVANNA
YEAR-TO-DATE BUDGET REPORT

P 1
glytddb

FOR 2017 12

ACCOUNTS FOR: 100	GENERAL FUND	ORIGINAL APPROP	REVISED BUDGET	YTD EXPENDED	MTD EXPENDED	ENCUMBRANCES	AVAILABLE BUDGET	PCT USED
350 ANIMAL CONTROL								
10035000	401100 SAL & WAGE	73,591	80,406	80,698.89	9,482.35	.00	-292.89	100.4%*
10035000	401300 PT SAL/WAG	0	0	.00	.00	.00	.00	.0%
10035000	401310 OT PAY	4,500	4,500	1,174.81	381.28	.00	3,325.19	26.1%
10035000	401320 HOLDISCPAY	0	0	3,600.03	220.32	.00	-3,600.03	100.0%*
10035000	401325 CNTRCTWAGE	0	0	.00	.00	.00	.00	.0%
10035000	402100 FICA	5,975	6,496	5,909.18	771.65	.00	586.82	91.0%
10035000	402210 VRS	7,785	7,339	6,363.76	570.46	.00	975.24	86.7%
10035000	402250 DISABILITY	0	0	.00	.00	.00	.00	.0%
10035000	402300 MEDINS	5,880	17,808	15,457.92	.00	.00	2,350.08	86.8%
10035000	402400 GRPLIFE	876	1,121	1,002.34	89.50	.00	118.66	89.4%
10035000	402600 UNEMPL	0	0	.00	.00	.00	.00	.0%
10035000	402700 WORKCOMP	1,229	787	786.88	.00	.00	.00	100.0%
10035000	402750 LINEOFDUTY	697	697	715.00	.00	.00	-18.00	102.6%*
10035000	403100 PROFSVCS	500	500	.00	.00	.00	500.00	.0%
10035000	403202 WASTEDISP	0	0	.00	.00	.00	.00	.0%
10035000	403300 CONTRSVC	128,750	128,750	129,691.25	10,708.33	.00	-941.25	100.7%*
10035000	403310 REP/MAINT	500	500	178.00	.00	.00	322.00	35.6%
10035000	403315 VEH REP/MN	4,800	4,800	4,824.42	.00	.00	-24.42	100.5%*
10035000	403600 ADVERT	500	500	.00	.00	.00	500.00	.0%
10035000	405110 ELECSVCS	0	0	.00	.00	.00	.00	.0%
10035000	405230 TELECOMM	1,265	1,265	1,678.30	179.92	.00	-413.30	132.7%*
10035000	405305 VEHICLEINS	1,000	1,000	975.00	.00	.00	25.00	97.5%
10035000	405510 MILEAGE	0	0	.00	.00	.00	.00	.0%
10035000	405530 SUB&LODG	1,000	1,000	505.32	.00	.00	494.68	50.5%
10035000	405540 CONVEDUC	750	750	630.00	250.00	.00	120.00	84.0%
10035000	405820 CLAIMS	2,500	2,500	1,152.26	.00	.00	1,347.74	46.1%
10035000	405825 S&N TAX	1,000	1,000	940.84	.00	.00	59.16	94.1%
10035000	405999 PENALTIES	0	0	.00	.00	.00	.00	.0%
10035000	406001 OFFSUPL	500	500	419.92	212.24	.00	80.08	84.0%
10035000	406003 AGRICSUPL	400	400	220.93	220.93	.00	179.07	55.2%
10035000	406005 JANITSUPL	0	0	.00	.00	.00	.00	.0%
10035000	406008 VEHFUEL	5,000	5,000	3,746.47	801.50	.00	1,253.53	74.9%
10035000	406009 VEHSUPL	600	600	633.38	.00	.00	-33.38	105.6%*
10035000	406011 UNIFORMS	1,500	1,500	952.06	931.02	.00	547.94	63.5%
10035000	406014 OTHEROPER	0	0	.00	.00	.00	.00	.0%
10035000	408105 VEHICLE	0	0	.00	.00	.00	.00	.0%
10035000	408107 EDPEQUIP	0	0	.00	.00	.00	.00	.0%
TOTAL ANIMAL CONTROL		251,098	269,719	262,256.96	24,819.50	.00	7,461.92	97.2%
TOTAL GENERAL FUND		251,098	269,719	262,256.96	24,819.50	.00	7,461.92	97.2%
TOTAL EXPENSES		251,098	269,719	262,256.96	24,819.50	.00	7,461.92	



11/07/2017 14:45
5311mtwi

COUNTY OF FLUVANNA
YEAR-TO-DATE BUDGET REPORT

P 2
glytdbud

FOR 2017 12

	ORIGINAL APPROP	REVISED BUDGET	YTD EXPENDED	MTD EXPENDED	ENCUMBRANCES	AVAILABLE BUDGET	PCT USED
GRAND TOTAL	251,098	269,719	262,256.96	24,819.50	.00	7,461.92	97.2%

** END OF REPORT - Generated by Mary Anna Twisdale **

County of Fluvanna

Carryover Request FY17/18

Office/Department: Fluvanna E911

General Ledger Account Title	FY17 Org Code	FY17 Object Code	FY18 Org Code (If Different)	FY18 Object Code (If Different)	Amount Requested	Justification: <u>Please answer all three questions.</u> Why should these funds be carried forward? Why was the project not completed within FY17? If this request is denied, what impact will it have on this Office/Department's ability to function efficiently?
1 Overtime Pay	10032000	401310			\$ 15,000.00	The new CAD implementation schedule requires a minimum of 40 hr of training for each Com Officer; training will occur during nonscheduled work hours. Training was a mandate by CAD system company, Spillman Technologies. Current FY-18 overtime line will not sufficiently cover the cost of training for this new CAD system.
2 Holiday & Disc	10032000	401320			\$ 10,000.00	The H&D line has consistently been insufficiently funded for the last 5 years, in FY-17 we were over budget by \$9,534.; during FY-17 we used very little discretionary time due to the absence of severe weather. If not funded this line will continue to operate in unfavorable budget variance.
3						
4						
5						
6						
Office/Department: Fluvanna E911					Total Carryover Amount Requested: \$ 25,000.00	



11/07/2017 14:45
5311mtwi

COUNTY OF FLUVANNA
YEAR-TO-DATE BUDGET REPORT

P 1
glytddb

FOR 2017 12

ACCOUNTS FOR: 100	GENERAL FUND	ORIGINAL APPROP	REVISED BUDGET	YTD EXPENDED	MTD EXPENDED	ENCUMBRANCES	AVAILABLE BUDGET	PCT USED
320 E911								
10032000	401100	540,816	555,107	500,479.86	58,004.05	.00	54,627.14	90.2%
10032000	401300	18,566	18,566	6,245.38	1,614.60	.00	12,320.62	33.6%
10032000	401310	21,364	21,364	23,062.38	2,638.78	.00	-1,698.38	107.9%*
10032000	401320	19,440	19,440	28,974.59	1,999.87	.00	-9,534.59	149.0%*
10032000	401333	3,500	3,500	.00	.00	.00	3,500.00	.0%
10032000	402100	37,675	38,768	41,423.05	4,914.18	.00	-2,655.05	106.8%*
10032000	402210	52,104	43,244	37,819.88	3,320.52	.00	5,424.12	87.5%
10032000	402250	596	596	990.34	95.70	.00	-394.34	166.2%*
10032000	402300	59,940	68,882	61,173.33	.00	.00	7,708.67	88.8%
10032000	402400	5,861	6,610	5,939.94	520.96	.00	670.06	89.9%
10032000	402600	0	0	.00	.00	.00	.00	.0%
10032000	402700	492	348	348.23	.00	.00	.00	100.0%
10032000	402830	0	0	.00	.00	.00	.00	.0%
10032000	403100	0	0	.00	.00	.00	.00	.0%
10032000	403125	0	0	875.00	875.00	.00	-875.00	100.0%*
10032000	403161	14,006	14,106	14,079.60	327.60	.00	26.40	99.8%
10032000	403162	0	0	.00	.00	.00	.00	.0%
10032000	403163	0	0	.00	.00	.00	.00	.0%
10032000	403300	46,000	46,000	45,450.00	8,175.00	.00	550.00	98.8%
10032000	403310	21,081	21,081	19,344.30	11,005.15	.00	1,736.70	91.8%
10032000	403320	57,885	75,885	79,507.68	2,659.66	.00	-3,622.68	104.8%*
10032000	405230	70,000	70,000	61,881.87	8,961.89	.00	8,118.13	88.4%
10032000	405305	0	0	.00	.00	.00	.00	.0%
10032000	405410	1,320	1,320	932.76	155.46	.00	387.24	70.7%
10032000	405510	500	500	.00	.00	.00	500.00	.0%
10032000	405530	2,000	1,900	209.68	83.28	.00	1,690.32	11.0%
10032000	405530	0	0	.00	.00	.00	.00	.0%
10032000	405540	2,000	2,000	1,045.00	1,045.00	.00	955.00	52.3%
10032000	405540	0	2,000	1,820.23	657.23	.00	179.77	91.0%
10032000	405810	500	500	466.00	.00	.00	34.00	93.2%
10032000	405999	0	0	.00	.00	.00	.00	.0%
10032000	406001	2,000	2,000	2,054.38	435.05	.00	-54.38	102.7%*
10032000	406008	0	0	.00	.00	.00	.00	.0%
10032000	406009	0	0	.00	.00	.00	.00	.0%
10032000	406011	1,200	1,200	1,301.24	29.26	.00	-101.24	108.4%*
10032000	406014	0	0	.00	.00	.00	.00	.0%
10032000	406015	0	0	.00	.00	.00	.00	.0%
10032000	406021	0	0	.00	.00	.00	.00	.0%
10032000	408102	0	0	.00	.00	.00	.00	.0%
10032000	408105	0	0	.00	.00	.00	.00	.0%



11/07/2017 14:45
5311mtwi

COUNTY OF FLUVANNA
YEAR-TO-DATE BUDGET REPORT

P 2
glytdbud

FOR 2017 12

ACCOUNTS FOR: 100 GENERAL FUND	ORIGINAL APPROP	REVISED BUDGET	YTD EXPENDED	MTD EXPENDED	ENCUMBRANCES	AVAILABLE BUDGET	PCT USED
<u>10032000 408107 EDPEQUIP</u>	2,000	2,000	1,997.40	1,695.89	.00	2.60	99.9%
TOTAL E911	980,846	1,016,917	937,422.12	109,214.13	.00	79,495.11	92.2%
TOTAL GENERAL FUND	980,846	1,016,917	937,422.12	109,214.13	.00	79,495.11	92.2%
TOTAL EXPENSES	980,846	1,016,917	937,422.12	109,214.13	.00	79,495.11	



11/07/2017 14:45
5311mtwi

COUNTY OF FLUVANNA
YEAR-TO-DATE BUDGET REPORT

P 3
glytbdud

FOR 2017 12

	ORIGINAL APPROP	REVISED BUDGET	YTD EXPENDED	MTD EXPENDED	ENCUMBRANCES	AVAILABLE BUDGET	PCT USED
GRAND TOTAL	980,846	1,016,917	937,422.12	109,214.13	.00	79,495.11	92.2%

** END OF REPORT - Generated by Mary Anna Twisdale **

FY17 to FY18 Carryover Requests - COUNTY

Department	Reason	Request Amount	FY17 Year End Balance	Approve	Deny	Defer
Clerk of Circuit Court	<p>Security and Disaster Recovery: These funds should be carried forward in support of on-going projects to address security upgrades and disaster recovery plans. Timing constraints and coordination of projects and the necessary HVAC upgrades as requested by public works have played a significant role in several projects remaining in their infancy. If denied FY18 funding will be deficient to carry out projects to address and implement necessary upgrades to ensure county safety, security and abidance of state policies</p>	\$26,000	Personnel: \$12,632.44 Operating: \$24,176.12			
Circuit Court Judge	<p>Security and Storage: These funds should be carried forward to implement progressive necessary changes which have become evident this year. The audio system in the court has become unreliable from years of use and mistreatment. Security risks need to minimized. The issues have only recently become evident, so time constraints have impacted completion. Court cannot effectively function with out these necessary audio and security improvements</p>	\$9,000	Personnel: \$13,215.14 Operating: \$15,943.12			
Sheriff's Office	<p>CAD Training Overtime: The new CAD implementation schedule requires a minimum of 24hr of training for each Deputy; training will occur during nonscheduled work hours. The 24 hr training was a mandate by Spillman Technologies. Current FY-18 overtime line will not sufficiently cover the cost of training for this new CAD system.</p>	\$7,000	Personnel: \$56,168.82 Operating: \$10,280.40			
Sheriff's Office	<p>Holiday and Discretionary Pay: The H&D line has consistently been insufficiently funded for the last 5 years, in FY-17 we were over budget by \$13,701; duringFY-17 we used very little discretionary time due to the absance of severe weather. If not funded this line will continue to operate in unfavorable budget variance.</p>	\$13,000	Personnel: \$56,168.82 Operating: \$10,280.40			
Sheriff's Office	<p>Convention & Education/Federal Law Enforcement Training for Mobile Devices: Application for the Federal Law Enforcement Training program for Mobile Device Investigations, was made in early 2017, but was not approved by the federal government until after the FY-18 budget began. Travel, lodging and meals were not provided, we did receive over \$20,000 in equipment such as mobile device extraction tools, a computer and a variety of software products used to extract information from mobile devices. If not funded this line will be in unfavorable budget variance at end of FY-18. Training for FY-18 has already been planned for the amount we requested in FY-18 budget.</p>	\$2,137	Personnel: \$56,168.82 Operating: \$10,280.40			
Sheriff's Office	<p>Police Supplies: In light of occurrences in the U.S. related to LEO and crowd control, we would like to purchase 34 helmets with face shields,10 new gas masks and 40 updated filters for our gas masks. We currently have 12 old military helmets without shields and 24 gas masks with expired filters. If denied we will submit this request for additional equipment during the FY-19 budget process.</p>	\$13,230	Personnel: \$56,168.82 Operating: \$10,280.40			

Department	Reason	Request Amount	FY17 Year End Balance	Approve	Deny	Defer
Sheriff's Office	Mobile Device Investigative Services: This request is to assure the proper equipment and techniques are deployed going forward with the Mobile Device Investigations. The requested items to be purchased could not have been budgeted for FY-18, because they would have been useless without the now completed training and examination equipment. If not funded we can not properly conduct the Mobil Device Investigations.	\$2,974	Personnel: \$56,168.82 Operating: \$10,280.40			
Animal Control	Holiday & Discretionary Pay: Budget is not aligned with Expenses. Holiday and Discretionary Funds were not funded in the FY18 Budget by the County Administration. ACO deputies are part of the Patrol Division, they are required to work Holidays. If not funded this budget line will continue operating in unfavorable budget variance.	\$6,000	Personnel: \$3,445.07 Operating: \$4,061.85			
Animal Control	Professional Services/Emergency Vet Care: Professional Services expense line was not sufficiently funded, we are currently over budget in this line, which covers emergency veterinary care not covered under the new SPCA contract for FY18. If not funded this budget line will continue operating in an unfavorable budget variance.	\$1,140	Personnel: \$3,445.07 Operating: \$4,061.85			
E911	CAD Training Overtime: The new CAD implementation schedule requires a minimum of 40 hr of training for each Com Officer; training will occur during nonscheduled work hours. Training was a mandate by CAD system company, Spillman Technologies. Current FY-18 overtime line will not sufficiently cover the cost of training for this new CAD system.	\$15,000	Personnel: \$69,968.25 Operating: \$ 9,526.86			
E911	Holiday and Discretionary Pay: The H&D line has consistently been insufficiently funded for the last 5 years, in FY-17 we were over budget by \$9,534.; during FY-17 we used very little discretionary time due to the absence of severe weather. If not funded this line will continue to operate in unfavorable budget variance.	\$10,000	Personnel: \$69,968.25 Operating: \$ 9,526.86			
Total Requests		\$105,481				

FLUVANNA COUNTY BOARD OF SUPERVISORS AGENDA ITEM

Meeting Date: November 15, 2017

TAB T

AGENDA TITLE:	FY17 to FY18 Schools Carryover Request										
MOTION(s):	<p>I move the Board of Supervisors [approve/deny/defer] carryover of FY17 Fluvanna County Public Schools unexpended local funds in the amount of \$_____, increasing the FY18 Schools local appropriation from \$17,260,315 to \$_____.</p> <p>I move the Board of Supervisors [approve/deny/defer] carryover of FY17 Fluvanna County Public Schools unexpended local funds in the amount of \$_____ to the FY18 CIP Budget (Schools), for the following items:</p> <table style="margin-left: 40px; width: 80%;"> <tr> <td>A. Buses -</td> <td style="text-align: right;">\$300,000</td> </tr> <tr> <td>B. Technology -</td> <td style="text-align: right;">\$85,000</td> </tr> <tr> <td>A. Student Transportation -</td> <td style="text-align: right;">\$50,000</td> </tr> </table>					A. Buses -	\$300,000	B. Technology -	\$85,000	A. Student Transportation -	\$50,000
A. Buses -	\$300,000										
B. Technology -	\$85,000										
A. Student Transportation -	\$50,000										
AGENDA CATEGORY:	Public Hearing	Action Matter	Presentation	Consent Agenda	Other						
		X									
STAFF CONTACT(S):	Mary Anna Twisdale, Management Analyst										
PRESENTER(S):	Chuck Winkler, Schools Superintendent Brenda Gilliam, Executive Director										
RECOMMENDATION:											
TIMING:	Routine.										
DISCUSSION:	<p>Fluvanna County Public Schools are requesting a local funds carryover from FY17 to FY18.</p> <p>The Fluvanna County School Board requests that \$675,000 of unexpended FY17 Funds be re-allocated to the school division. Said funds are to be divided accordingly:</p> <ul style="list-style-type: none"> • \$400,000 to CIP (Buses, Technology and Vehicles) • \$275,000 to FY18 General Operating. 										
FISCAL IMPACT:	This supplemental appropriation, if approved, would authorize staff to appropriate the additional funds to FY18 revenue and expenditures in the Fluvanna County Public Schools general operating budget.										
POLICY IMPACT:	None										
LEGISLATIVE HISTORY:	N/A										

ENCLOSURES:	None.				
REVIEWS COMPLETED:	Legal	Finance	Purchasing	HR	Other
		X			



FLUVANNA COUNTY PUBLIC SCHOOLS

OFFICE OF THE SUPERINTENDENT

14455 JAMES MADISON HIGHWAY
PALMYRA, VIRGINIA 22963
(434) 589-8208

November 9, 2017

Steven M. Nichols, County Administrator
Fluvanna County
Post Office Box 540
Palmyra, VA 22963

Dear Mr. Nichols,

At their November 8th meeting, the Fluvanna County School Board directed me to deliver the following to the Fluvanna County Board of Supervisors:

The Fluvanna County School Board requests that \$675,000 of un-expended Fiscal Year 2017 Funds be re-allocated to the school division. Said funds are to be divided accordingly:

- \$435,000 to CIP (Buses, Technology, and Vehicles)
- \$240,000 to FY18 General Operating.

I am asking that our request be included on the Board of Supervisors agenda for November 15, 2017. In my absence, Mrs. Gilliam plans to attend this meeting to provide a more detailed explanation. If you have questions prior to this time, please contact me at 434-589-8208.

Respectfully Submitted,

Chuck A. Winkler
Superintendent

CC:

Mr. Eric Dahl
Mrs. Brenda Gilliam
Mrs. Carol Carr

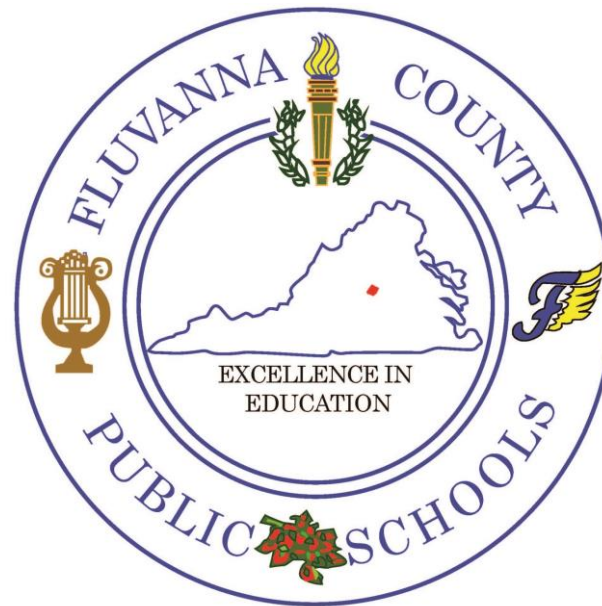

Fluvanna County Public Schools

**FINANCIAL REPORT
FISCAL YEAR 2017
Carryover Request
November 15, 2017**

FY2017 Update- Expenditures

Category	Appropriations	Expenditures YTD	Available Balance	Percent Used
Instruction	\$28,492,586.75	\$28,172,360.50	\$320,226.25	98.88%
Admin, Attendance & Health	\$1,720,170.00	\$1,707,257.40	\$12,912.60	99.25%
Pupil Transportation	\$3,002,355.95	\$2,646,854.49	\$355,501.46	88.16%
Operations	\$4,012,522.94	\$3,363,854.36	\$648,668.58	83.83%
Technology	\$2,050,850.48	\$1,715,442.76	\$35,407.73	83.65%
	\$39,278,486.12	\$37,605,769.51	\$1,672,716.62	95.74%

FY2017 Update- Revenues

Source	EST. REVENUE for FY2017	REVENUE YTD	UNREALIZED BALANCE	PERCENT REALIZED
Local (County)*	\$16,885,315.00	\$15,760,524.68	\$1,124,790.32	93.34%
Local (Other)	\$874,488.65	\$760,740.57	\$113,748.08	86.99%
State	\$20,242,002.68	\$19,847,018.34	\$394,984.34	98.05%
Federal	\$1,276,679.79	\$1,237,485.92	\$39,193.87	96.93%
Total	\$39,278,486.12	\$37,605,769.51	\$1,672,716.61	95.74%

REASONS BEHIND CARRYOVER FUNDS FY2017

Received additional state funds late in the FY2017- Totaling- approximately \$500,000

- Class Size Reduction- \$82,827.00
- Enrollment Loss Fund- Small School Money- \$127,920
- Enrollment Increase- \$278,061

Software License Renewal Dates Changed to July- approximately \$140,000

- Instructional-\$49,680
- Technology- \$86,467

TOTAL= \$640,000

Budget Adjustments for FY2018

Non-Local Carryover

Source	Type	Amount	Expenditure Category	Notes
Blue Ridge Virtual Governor's School (BRVGS)	State	\$19,951.16	Instruction	Expires 06/30/2018
Families Learning Together	Other Local	\$4,640.53	Instruction	
i3- January-December 2016	Other Local	\$6,753.17	Instruction	Expires 12/31/2017
i3- January-December 2017	Other Local	\$16,540.29	Instruction	Expires 12/31/2018
Immigrant Youth	Federal	\$1,132.89	Instruction	Expires 09/30/2018
Title I	Federal	\$52,676.86	Instruction	Expires 09/30/2018
Title II	Federal	\$14,317.75	Instruction	Expires 09/30/2018
Title III	Federal	\$2,255.35	Instruction	Expires 09/30/2018
Title VIB- 2015	Federal	\$53,156.05	Instruction	Expires 09/30/2017
Title VIB- 2016	Federal	\$65,968.59	Instruction	Expires 09/30/2018
Special Education Transition Grant	Federal	\$2,000.00	Instruction	Expires 09/30/2017
Project RETURN	State	\$14,839.46	Instruction	Expires 06/30/2018
VPSA- Fluvanna	State	\$180,000.00	Technology	
TOTAL			\$434,232.10	

Request Submitted: August 23, 2017

Proposed Revised Carryover Request

Funds to cover unanticipated costs- \$165,000

Laptops received after June 30

Bus Replacement exceeding Capital Reserve

Vehicle Replacement- \$50,000

71 cars, trucks, and vans in the fleet

48 of the vehicles are 2002 or older

Cars needed for student transport

Trucks needed for maintenance staff

School Bus Replacement- 3 buses at \$300,000

28 buses in fleet are 2001 or older

19 buses 2001 or older on daily routes

Suggested replacement cycle 15 years

Will take fewer years to achieve suggested replacement cycle

Additional Technology needs- \$85,000

Chromebook Carts and other Instructional Technology Needs

Adjustments to Personnel Compensation Schedules- \$75,000

Total Request= \$675,000

Remaining Balance to return to County- \$563,484.52

FY17 to FY18 Carryover Requests - SCHOOLS

Department	Reason	Request Amount	FY17 Year End Balance	Approve	Deny	Defer
To FY 18 Operating Budget						
Schools	Funds to cover unanticipated costs: - Laptops received after June 30 - Bus Replacement exceeding Capital Reserve	\$165,000				
Schools	Adjustments to Personnel Compensation Schedules	\$75,000				
To FY 18 CIP Budget						
Schools	Vehicle Replacement: - 71 cars, trucks, and vans in the fleet - 48 of the vehicles are 2002 or older - Cars needed for student transport - Trucks needed for maintenance staff	\$50,000	Personnel: \$56,168.82 Operating: \$10,280.40			
Schools	School Bus Replacement (3 buses): - 28 buses in fleet are 2001 or older - 19 buses 2001 or older on daily routes - Suggested replacement cycle 15 years - Will take fewer years to achieve suggested replacement cycle	\$300,000	Personnel: \$56,168.82 Operating: \$10,280.40			
Schools	Additional Technology needs: - Chromebook Carts and other Instructional Technology Needs	\$85,000	Personnel: \$56,168.82 Operating: \$10,280.40			
Total Requests		\$675,000				



FY17 to FY18 Carryover Requests

**Mary Anna Twisdale
Management Analyst**



Fluvanna County Financial Policies Section 1-10 (Re-appropriation)

BoS Packet 2017-1-16 P 154/223



Four Reasons for FY17 Carryover Requests

- Meets existing policy.
- Meets existing policy.
- Does not meet existing policy.
- i.e., Not funded in FY18, but request/need has been identified; asking for unexpended FY17 dollars to cover that request/need (rather than wait until FY19 budget).
- Does not meet existing policy.



FY17 to FY18 Carryover Requests

BOS Packet 2017-11-15 P.156/223

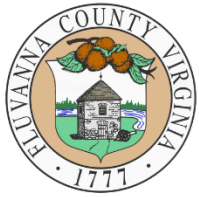

FY17 to FY18 County Carryover Motion



FY17 to FY18 Schools Carryover Motions



Questions?

**FLUVANNA COUNTY BOARD OF SUPERVISORS
AGENDA ITEM STAFF REPORT**

TAB U

MEETING DATE:	November 15, 2017				
AGENDA TITLE:	Request to Rescind Resolution 17-2009 GIS Mapping Fees				
MOTION(s):	I move to rescind Resolution 17-2009 GIS Mapping Fees, in order to comply with the current Freedom of Information Act legislation.				
STRATEGIC INITIATIVE?	Yes	No	If yes, list initiative(s):		
		XX			
AGENDA CATEGORY:	Public Hearing	Action Matter	Presentation	Consent Agenda	Other
		XX			
STAFF CONTACT(S):	Kelly Belanger Harris, Clerk to the Board, FOIA Officer				
PRESENTER(S):	Fred Payne, County Attorney				
RECOMMENDATION:	Approve				
TIMING:	Normal				
DISCUSSION:	<p>Updates to FOIA law allow localities to charge "actual costs" and not flat fees for records request.</p> <p>The original Resolution (attached) stated: WHEREAS, under the Freedom of Information Act, localities are allowed to charge fees for such services; and, WHEREAS, GIS mapping and data requests are routine; and, WHEREAS, there is no ability for Planning Department staff to recuperate costs for these services without an adopted fee structure;</p> <p>Rescinding the Resolution brings requests for GIS Mapping and Data into compliance with current FOIA.</p>				
FISCAL IMPACT:	Decrease in fees collected for certain FOIA requests				
POLICY IMPACT:	Compliance with 2017 Freedom of Information Act				
LEGISLATIVE HISTORY:	None.				
ENCLOSURES:	Resolution #17-2009 - "Resolution GIS Mapping Fees"				
REVIEWS COMPLETED:	Legal	Finance	Purchasing	HR	Other



BOARD OF SUPERVISORS
County of Fluvanna
Palmyra, Virginia

RESOLUTION
GIS Mapping Fees

At a regular monthly meeting of the Fluvanna County Board of Supervisors held on Wednesday, June 17, 1009, in Palmyra, Virginia, the following action was taken:

<u>Present</u>	<u>Vote</u>
Marvin F. Moss, Chairman	YEA
Charles W. Allbaugh, Vice-Chairman	YEA
Mozell H. Booker	YEA
John Y. Gooch	YEA
Gene F. Ott	YEA
Donald W. Weaver	YEA

On a motion by Mr. Weaver seconded by Mr. Gooch and voted in the affirmative, the following resolution was adopted:

WHEREAS, the Fluvanna County Planning Department currently has no adopted fee schedule for GIS mapping and data request services; and,

WHEREAS, under the Freedom of Information Act, localities are allowed to charge fees for such services; and,

WHEREAS, GIS mapping and data requests are routine; and,

WHEREAS, there is no ability for Planning Department staff to recuperate costs for these services without an adopted fee structure;

NOW, THEREFORE, BE IT RESOLVED that the Fluvanna County Board of Supervisors hereby adopts the following fee schedule for GIS mapping and data request services:

GIS Maps . . .

- Smaller Than 11x17 \$ 10.00
- 11x17 and Larger \$ 20.00
- Special Project \$ 50.00

GIS Data Requests . . .

- Less Than 5 Layers \$ 25.00
- 5-10 Layers \$ 50.00
- More Than 10 Layers \$ 75.00;

Marvin F. Moss, Chairman

**FLUVANNA COUNTY BOARD OF SUPERVISORS
AGENDA ITEM STAFF REPORT**

TAB V

MEETING DATE:	November 15, 2017				
AGENDA TITLE:	Charlottesville Area Alliance Support Resolution				
MOTION(s):	I move the Board of Supervisors adopt the resolution entitled, "Charlottesville Area Alliance Support Resolution."				
STRATEGIC INITIATIVE?	Yes	No	If yes, list initiative(s):		
		XX			
AGENDA CATEGORY:	Public Hearing	Action Matter	Presentation	Consent Agenda	Other
		XX			
STAFF CONTACT(S):	Steven M. Nichols, County Administrator				
PRESENTER(S):	Steven M. Nichols, County Administrator				
RECOMMENDATION:	Approve				
TIMING:	Normal				
DISCUSSION:	<p>This action would lend Fluvanna County support for the ongoing and expanding efforts of the new Charlottesville Area Alliance with regard to senior needs and services.</p> <p>See Resolution and briefing provided at the Nov 1st BOS Meeting.</p>				
FISCAL IMPACT:	None.				
POLICY IMPACT:	None.				
LEGISLATIVE HISTORY:	None.				
ENCLOSURES:	<ul style="list-style-type: none"> • Resolution • CAA Briefing 				
REVIEWS COMPLETED:	Legal	Finance	Purchasing	HR	Other



BOARD OF SUPERVISORS
County of Fluvanna
Palmyra, Virginia

RESOLUTION No. 16-2017

CHARLOTTESVILLE AREA ALLIANCE SUPPORT RESOLUTION

WHEREAS, the Charlottesville Area Alliance (CAA) is a collective of organizations who aim to lead the advancement of goals making the Region 10 an age friendly community, being mindful of the unique needs of those aging in this regional community and taking action when needed; and

WHEREAS, the Charlottesville Area Alliance (CAA) is comprised of five to ten “Lead Organizations” including The Alzheimer’s Association, Jefferson Area Board on Aging, The Senior Center, JAUNT Inc., Westminster Canterbury of the Blue Ridge, Region 10, Sentara Martha Jefferson Hospital, UVA Health Center United Way and Thomas Jefferson Planning District Commission as the initial lead organizations; and

WHEREAS, the CAA is a regional alliance with the goal to assist and interact with all of the jurisdictions of Region 10 including the City of Charlottesville and the Counties of Albemarle, Fluvanna, Greene, Louisa and Nelson; and

WHEREAS, the CAA’s primary purpose is to provide leadership for and to develop an age-friendly community through educating, advocating, engagement, planning, and evaluation, bringing organizations together to create an age-friendly community by developing a common understanding of the needs and issues, developing policy recommendations, and joining together to encourage the implementation by government, non-profit organizations, the general public and businesses; and

WHEREAS, the mission of the Charlottesville Area Alliance is to lead the advancement of an age friendly community, and the vision of the CAA is, "The Greater Charlottesville area will be the most Age-Friendly community in the country," and

WHEREAS, The CAA has identified five goal areas of work including: 1) **Assessment/Monitoring** 2) **Planning** 3) **Advocacy** 4) **Education & Public Relations** 5) **Engagement**; and

WHEREAS, the CAA will utilize the World Health Organization’s measurement/indicators of Outdoor Spaces & Buildings, Transportation, Housing, Social Participation, Respect & Social Inclusion, Civil Participation & Employment, Communication & Information, and Community & Health Services; and

WHEREAS, according to the United States Census Bureau, Fluvanna County has seen an increase in population of individuals 65 years old or older rise from 15.7% of the County population in 2010 to 19.4% in 2016 with 5,097 people 65 or over; and

WHEREAS, Fluvanna County identifies that it is important for County staff and citizens to include elderly and age friendly consideration and advancement in all efforts of its strategic planning including the Natural Environment, Infrastructure, Transportation, Economic Development, Historic Preservation, Parks & Recreation, Housing, Human Services, Education, Public Safety, and Financial Sustainability; and

NOW, THEREFORE BE IT RESOLVED, on this 15th day of November, 2017, that the Fluvanna County Board of Supervisors hereby endorses the organization of the Charlottesville Area Alliance and supports the staff and citizen involvement in the ongoing efforts of the CAA.

THE FOREGOING RESOLUTION WAS DULY AND REGULARLY ADOPTED by the Fluvanna County Board of Supervisors at the regular meeting of the Board held on the 15th day of November, 2017;

	AYE	NAY	ABSTAIN	ABSENT	MOTION	SECOND
Mozell H. Booker, Fork Union District						
Patricia B. Eager, Palmyra District						
Anthony P. O'Brien, Rivanna District						
John M. Sheridan, Columbia District						
Donald W. Weaver, Cunningham District						

Attest:

John M. Sheridan, Chair
 Fluvanna County Board of Supervisors



charlottesville
area

alliance

working together for an age-friendly community



One in four.

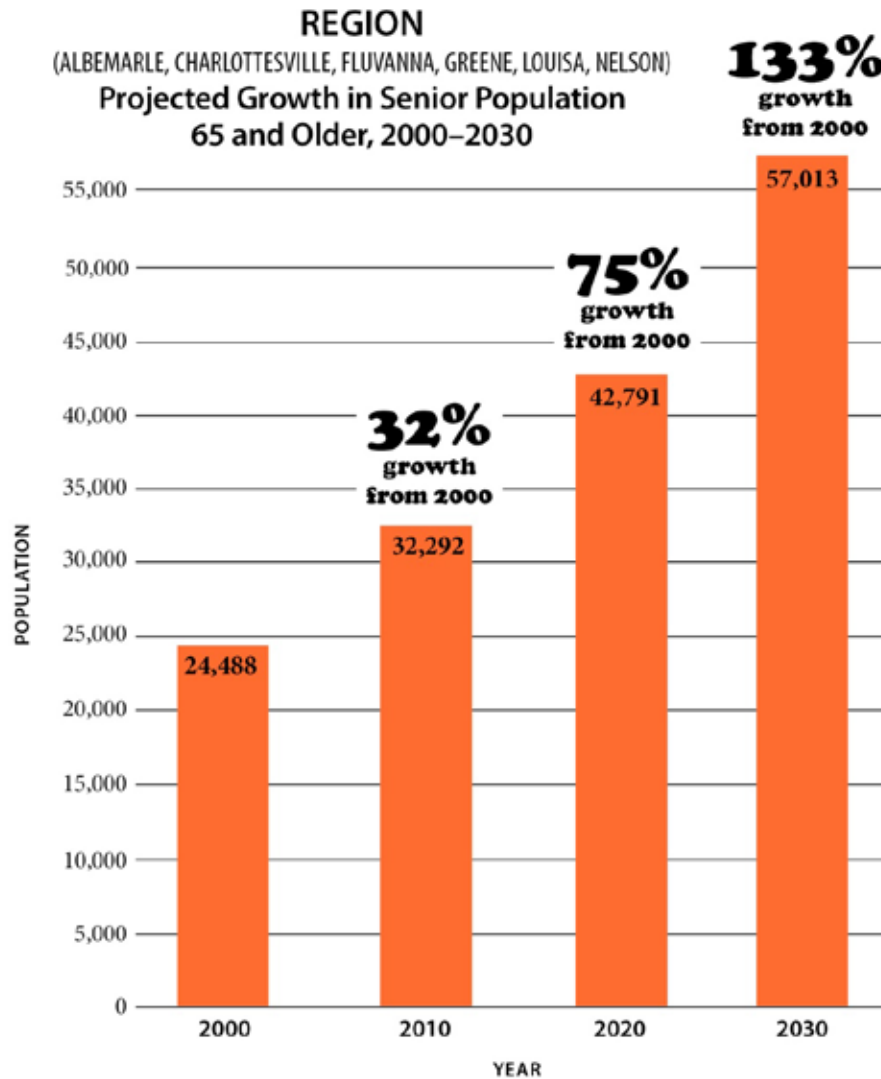

ALBEMARLE COUNTY

Projected Growth in Senior Population 65 and Older, 2000–2030

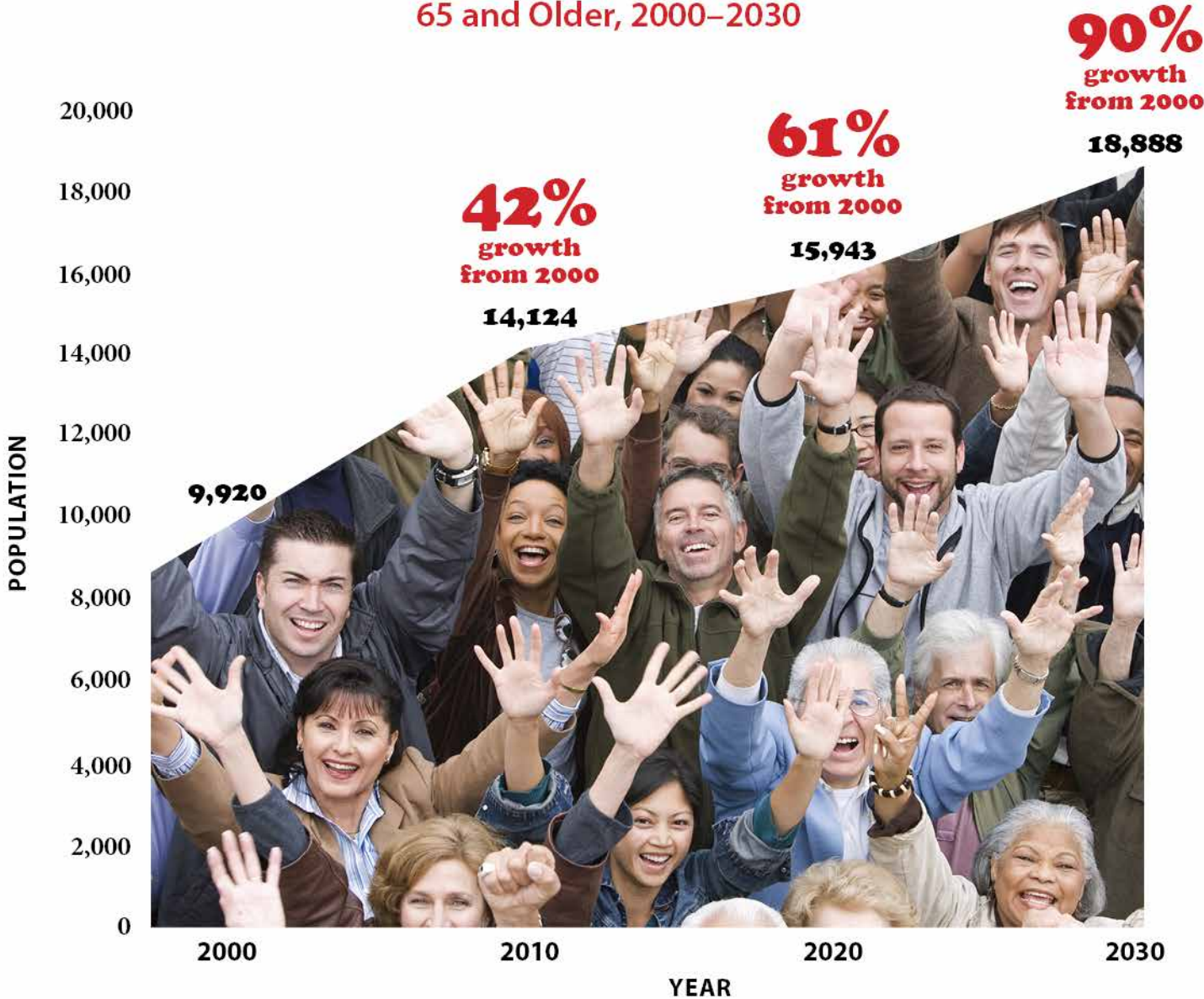

CITY OF CHARLOTTESVILLE

Projected Growth in Senior Population 65 and Older, 2000–2030



What does age-friendly mean?

Age-friendly *not* is about old people.
^

What does age-friendly mean?



AGE-FRIENDLY = GOOD FOR EVERYONE

Plan for the needs of an aging population and we automatically check off the needs of all constituents.

“Winning communities in the future will be the ones that invest in creating great places to live, work, learn, and play at every age. Charlottesville Area Alliance is the right idea at the right time.”

Matt Thornhill

Founder & President, Boomer Project & Generations *Matter*

2014



2015



Now



vision

greater Charlottesville area to be
the most age-friendly community
in the country



mission

lead the advancement of an
age-friendly community

Goals



8 LIFE ELEMENTS

FOR AN AGE-FRIENDLY COMMUNITY



Organizational Structure



Partners

Advocates, leaders, contributors, and stakeholders in the community serving or advising the senior population.



Steering Committee

Composed 13 members, with core of "lead organizations."



Work Groups

Five standing work groups align with Alliance goals.



We invite Fluvanna County to support the process of becoming an age-friendly community!



Thank you!

**FLUVANNA COUNTY BOARD OF SUPERVISORS
AGENDA ITEM STAFF REPORT**

TAB W

MEETING DATE:	November 15, 2017				
AGENDA TITLE:	Fluvanna County Reassessment Process Proposal				
MOTION(S):	I move the Board of Supervisors authorize staff to prepare a Request for Proposals (RFP) to conduct two general reassessments of the real property and improvements within the County with the first to become effective as of January 1, 2019, and the second general assessment to become effective on January 1, 2021.				
STRATEGIC INITIATIVE?	Yes	No	If yes, list initiative(s):		
		X			
AGENDA CATEGORY:	Public Hearing	Action Matter	Presentation	Consent Agenda	Other
		X			
STAFF CONTACT(S):	Cyndi Toler, Purchasing Officer ; Mel Sheridan, Commissioner of the Revenue				
PRESENTER(S):	Cyndi Toler, Purchasing Officer				
RECOMMENDATION:	recommend approval				
TIMING:	Routine				
DISCUSSION:	<p><i>§ 58.1-3254. Reassessment by direction of governing body. Notwithstanding any other provision of this article to the contrary, there may be a general reassessment of real estate in any county or city in any year if the governing body so directs by a majority of all the members thereof, by a recorded yea and nay vote. If such general reassessment is conducted, further general reassessments shall be required only every fourth year thereafter for counties, or every second year thereafter for cities notwithstanding the provisions of § 58.1-3250 and 58.1-3252 to the contrary.</i></p> <p>In order to schedule a general reassessment other than every 4 years, the board must approve a resolution to do so. This was last approved by the board in Sept 2013 allowing for the reassessments in 2015 and 2017.</p>				
FISCAL IMPACT:	Will allow for better budgeting of the known contract costs over the period				
POLICY IMPACT:	Allows for increased frequency of assessments and setting of equalized tax rates to account for economic changes.				
LEGISLATIVE HISTORY:	N/A				
ENCLOSURES:					
REVIEWS COMPLETED:	Legal	Finance	Purchasing	HR	Other
	X	X	X		X-COR

**FLUVANNA COUNTY BOARD OF SUPERVISORS
AGENDA ITEM STAFF REPORT**

TAB X

MEETING DATE:	November 15, 2017				
AGENDA TITLE:	ARC Facility Upgrades				
MOTION(s):	N/A				
STRATEGIC INITIATIVE?	Yes	No	If yes, list initiative(s):		
		XX			
AGENDA CATEGORY:	Public Hearing	Action Matter	Presentation	Consent Agenda	Other
			XX		
STAFF CONTACT(S):	Wayne Stephens, Public Works Director/County Engineer and Mel Sheridan, Commissioner of the Revenue				
PRESENTER(S):	Wayne Stephens, Public Works Director/County Engineer				
RECOMMENDATION:	Information				
TIMING:	Current				
DISCUSSION:	<p>The ARC Building in Kent's Store is used throughout the year for County functions and events, including: Primary and General Election Polling Place for the Columbia District, Senior Activities Center (Parks & Recreation), and Community Town Halls and other meetings.</p> <p>The facility has inadequate heating, lighting, and kitchen facilities, and no air conditioning. It may be in the best interest of Fluvanna County to collaborate on facility upgrades to better serve residents in that area of the county, and to establish an agreement for continued use of the facility, and to ensure free use of the facility for County-sponsored functions.</p> <p>This briefing will present a list of needed upgrades and associated costs, and seek feedback from the Board for a potential way ahead.</p>				
FISCAL IMPACT:	TBD				
POLICY IMPACT:	None.				
LEGISLATIVE HISTORY:	None.				
ENCLOSURES:	.				
REVIEWS COMPLETED:	Legal	Finance	Purchasing	HR	Other



COUNTY OF FLUVANNA

"Responsive & Responsible Government"

BOS Packet 2017-11-15 P.187/223

P.O. Box 540

Palmyra, VA 22963

(434) 591-1910

Fax (434) 591-1911

www.fluvannacounty.org

TAB YZ

MEMORANDUM

Date: November 15, 2017
From: Finance Department
To: Board of Supervisors
Subject: Accounts Payable Report for October 2017

1. Staff recommends that the Board of Supervisors ratify the expenditures in the attached report and summarized below.

CATEGORY	AMOUNT
General	\$1,006,087.39
Capital Improvements	\$761,043.72
Debt Service	\$0.00
Sewer	\$6,920.60
Fork Union Sanitary District	\$9,385.19
TOTAL AP EXPENDITURES	\$1,783,436.90
Payroll	\$762,442.95
TOTAL	\$2,545,879.85

MOTION

I move the Accounts Payable and Payroll be ratified for **October 2017** in the amount of **\$2,545,879.85**.

Encl:
AP Report

	A	B	C	D	F	G	H	J	
1	County of Fluvanna		From Date: 10/1/2017						
2	Accounts Payable List		To Date: 10/31/2017						
3									
4									
6	Vendor Name	Charge To	Description	Invoice Number	Invoice Date	Check Date	Check Amount		
7	Fund # - 100 GENERAL FUND								
8	GENERAL FUND								
9	MINNESOTA LIFE INS. CO	CLEARING ACCOUNT-	Payroll Run 1 - Warrant 100617	000000055779	10/5/2017	10/26/2017	146.95		
10	MINNESOTA LIFE INS. CO	CLEARING ACCOUNT-	Payroll Run 1 - Warrant 102017	000000056185	10/19/2017	10/26/2017	146.99		
11	ST PETERS & PAUL CATHOLIC CHURCH	PLANNING ESCROW	EROSION CASH BOND RELEASE REFUND	101117	10/11/2017	10/13/2017	4,800.00		
12	VACORP	CLEARING ACCOUNT-	Payroll Run 1 - Warrant 100617	000000055780	10/5/2017	10/26/2017	431.81		
13	VACORP	CLEARING ACCOUNT-	Payroll Run 1 - Warrant 102017	000000056186	10/19/2017	10/26/2017	456.66		
14								Total:	\$5,982.41
15									
16	REAL ESTATE TAXES								
17	COSNER ASSET PROTECTION TRUST	R E 2017 - 1ST	RE 2017 3-22-A	56356	10/27/2017	10/27/2017	3,934.79		
18	FLUVANNA COUNTY FARM BUREAU, INC.	R E 2017 - 1ST	RE 2017 51A-A-35	56357	10/27/2017	10/27/2017	878.88		
19	GARCIA, JOSE G	R E 2017 - 1ST	RE 2017 49-6-4	56358	10/27/2017	10/27/2017	204.08		
20	HOGG, RICHARD W & RUTH M	R E 2017 - 1ST	RE 2017 8-8-B	56359	10/27/2017	10/27/2017	577.76		
21	KALOGERA, LAWRENCE R & BARBARA	R E 2016 - 1ST	RE 2016 22-A-90D	56354	10/27/2017	10/27/2017	332.41		
22	LIBERTY HOMES INC	R E 2017 - 1ST	RE 2017 18-A-33	56355	10/27/2017	10/27/2017	158.72		
23								Total:	\$6,086.64
24									
25	OTHER LOCAL TAXES								
26	COMMONWEALTH BUILDING MATERIALS INC	ADMIN FEE VEHICLE LICENSE	PP 2017 210582	56360	10/27/2017	10/27/2017	132.06		
27	HILL, DESIREE' ANTONETTE	ADMIN FEE VEHICLE LICENSE	PP 2017 6808	56361	10/27/2017	10/27/2017	2.92		
28								Total:	\$134.98
29									
30	PERMITS/FEES/LICENSES								
31	SYCAMORE SQUARE LLC	BUILDING PERMITS	SIGN DEPOSIT RETURN;ZMP 17:02	101917	10/24/2017	10/27/2017	90.00		
32								Total:	\$90.00
33									
34	STATE - CATEGORICAL AID								
35	TREASURER OF VIRGINIA	VJCCA GRANT OFFICE ON	REFUND OF FUNDS NOT EXPENDED FOR FY17	102717	6/30/2017	10/30/2017	1,009.96		
36								Total:	\$1,009.96
37									
38	BOARD OF SUPERVISORS								
39	BANK OF AMERICA	ADVERTISING	P-CARD PURCHASES	093017	10/17/2017	10/20/2017	149.95		
40	BANK OF AMERICA	CONVENTION AND	P-CARD PURCHASES	093017	10/17/2017	10/20/2017	675.00		
41	BANK OF AMERICA	OTHER OPERATING	P-CARD PURCHASES	093017	10/17/2017	10/20/2017	7.15		
42	BANK OF AMERICA	OTHER OPERATING	P-CARD PURCHASES	093017	10/17/2017	10/20/2017	16.36		
43	BANK OF AMERICA	OTHER OPERATING	P-CARD PURCHASES	093017	10/17/2017	10/20/2017	25.38		
44	BANK OF AMERICA	OTHER OPERATING	P-CARD PURCHASES	093017	10/17/2017	10/20/2017	25.56		
45	BANK OF AMERICA	OTHER OPERATING	P-CARD PURCHASES	093017	10/17/2017	10/20/2017	172.17		
46	DONALD WEAVER	MILEAGE ALLOWANCES	MILEAGE	011217	9/27/2017	10/20/2017	164.25		
47	FLUVANNA REVIEW	ADVERTISING	PAGE AD	2017F40-13	10/11/2017	10/13/2017	297.50		
48	FLUVANNA REVIEW	ADVERTISING	PADE AD	2017F41-7	10/18/2017	10/20/2017	78.75		



	A	B	C	D	F	G	H	J	
1	County of Fluvanna		From Date: 10/1/2017						
2	Accounts Payable List		To Date: 10/31/2017						
3									
4									
6	Vendor Name	Charge To	Description		Invoice Number	Invoice Date	Check Date	Check Amount	
49	FLUVANNA REVIEW	ADVERTISING	PADE AD		2017F41-7	10/18/2017	10/20/2017	297.50	
50	MATTHEW BENDER & CO INC	BOOKS/PUBLICATIONS	VA CODE		093017	10/11/2017	10/13/2017	160.03	
51	NACO	DUES OR ASSOCIATION	RENEWAL		200265	10/11/2017	10/13/2017	460.00	
52	SHENANDOAH PUBLICATIONS, INC.	PRINTING AND BINDING	REPORT TO CITIZENS		44834	10/11/2017	10/13/2017	2,687.28	
53	VERIZON	TELECOMMUNICATIONS	WIRELESS		9794804823	10/24/2017	10/27/2017	158.85	
54								Total:	\$5,375.73
55									
56	COUNTY ADMINISTRATOR								
57	BANK OF AMERICA	OFFICE SUPPLIES	P-CARD PURCHASES		093017	10/17/2017	10/20/2017	22.31	
58	BANK OF AMERICA	OFFICE SUPPLIES	P-CARD PURCHASES		093017	10/17/2017	10/20/2017	27.95	
59	BANK OF AMERICA	OFFICE SUPPLIES	P-CARD PURCHASES		093017	10/17/2017	10/20/2017	409.75	
60	CENTURYLINK	TELECOMMUNICATIONS	FINANCE		309762613 091617	10/4/2017	10/6/2017	10.13	
61	FLUVANNA COUNTY CHAMBER OF	DUES OR ASSOCIATION	CHAMBER DUES		100317	10/11/2017	10/13/2017	380.00	
62	FLUVANNA REVIEW	ADVERTISING	PAGE AD		2017F37-7	10/11/2017	10/13/2017	236.25	
63	KODIAK, LLC.	LEASE/RENT	SHRED		64579	10/11/2017	10/13/2017	35.00	
64	STAPLES CONTRACT & COMMERCIAL, INC.	OFFICE SUPPLIES	SUPPLIES		8046663058	10/18/2017	10/20/2017	60.71	
65	THE SUPPLY ROOM	LEASE/RENT	SPRING WATER		3091928-0	10/4/2017	10/6/2017	59.88	
66	THE SUPPLY ROOM	OFFICE SUPPLIES	SUPPLIES		3094629-0	10/11/2017	10/13/2017	41.86	
67	VIRGINIA BUSINESS SYSTEMS	LEASE/RENT	STAPLER FINISHER		21400763	10/11/2017	10/13/2017	47.59	
68								Total:	\$1,331.43
69									
70	COUNTY ATTORNEY								
71	PAYNE & HODOUS, LLP.	PROFESSIONAL SERVICES	LEGAL FEES		125827 125691	10/11/2017	10/13/2017	22.47	
72	PAYNE & HODOUS, LLP.	PROFESSIONAL SERVICES	LEGAL FEES		125827 125691	10/11/2017	10/13/2017	23,699.71	
73								Total:	\$23,722.18
74									
75	COMMISSIONER OF THE REVENUE								
76	BANK OF AMERICA	BLDGS EQUIP REP & MAINT	P-CARD PURCHASES		093017	10/17/2017	10/20/2017	62.68	
77	BANK OF AMERICA	LEASE/RENT	P-CARD PURCHASES		093017	10/17/2017	10/20/2017	52.00	
78	BANK OF AMERICA	OFFICE SUPPLIES	P-CARD PURCHASES		093017	10/17/2017	10/20/2017	146.39	
79	BANK OF AMERICA	OFFICE SUPPLIES	P-CARD PURCHASES		093017	10/17/2017	10/20/2017	153.60	
80	BANK OF AMERICA	SUBSISTENCE & LODGING	P-CARD PURCHASES		093017	10/17/2017	10/20/2017	24.99	
81	BANK OF AMERICA	SUBSISTENCE & LODGING	P-CARD PURCHASES		093017	10/17/2017	10/20/2017	27.18	
82	BANK OF AMERICA	SUBSISTENCE & LODGING	P-CARD PURCHASES		093017	10/17/2017	10/20/2017	29.34	
83	BANK OF AMERICA	SUBSISTENCE & LODGING	P-CARD PURCHASES		093017	10/17/2017	10/20/2017	285.02	
84	BANK OF AMERICA	SUBSISTENCE & LODGING	P-CARD PURCHASES		093017	10/17/2017	10/20/2017	292.58	
85	CENTURYLINK	TELECOMMUNICATIONS	FINANCE		309762613 091617	10/4/2017	10/6/2017	16.88	
86	KODIAK, LLC.	LEASE/RENT	SHRED		64579	10/11/2017	10/13/2017	15.00	
87	NATIONAL APPRAISAL GUIDES	PRINTING AND BINDING	USED CAR GUIDE		317080 92617	10/24/2017	10/27/2017	100.00	
88	PITNEY BOWES INC	OFFICE SUPPLIES	SUPPLIES		1005346824	10/4/2017	10/6/2017	91.98	
89	PITNEY BOWES INC	OFFICE SUPPLIES	SUPPLIES		1005346823	10/4/2017	10/6/2017	148.82	
90	PRICE DIGEST	PRINTING AND BINDING	MARINE BLUE BOOK		67760716	10/11/2017	10/13/2017	276.95	



	A	B	C	D	F	G	H	J	
1	County of Fluvanna		From Date: 10/1/2017						
2	Accounts Payable List		To Date: 10/31/2017						
3									
4									
6	Vendor Name	Charge To	Description	Invoice Number	Invoice Date	Check Date	Check Amount		
91	STAPLES CONTRACT & COMMERCIAL, INC.	OFFICE SUPPLIES	SUPPLIES	8046663058	10/18/2017	10/20/2017	8.99		
92	STAPLES CONTRACT & COMMERCIAL, INC.	OFFICE SUPPLIES	SUPPLIES	8046663058	10/18/2017	10/20/2017	42.56		
93	STONEWALL TECHNOLOGIES	PROFESSIONAL SERVICES	VAMANET MEMBERSHIP	8910	10/11/2017	10/13/2017	300.00		
94	THE SUPPLY ROOM	LEASE/RENT	COOLER RENTAL	3100028-0	10/11/2017	10/13/2017	9.99		
95	VERIZON	TELECOMMUNICATIONS	WIRELESS	9794804823	10/24/2017	10/27/2017	50.08		
96								Total:	\$2,135.03
97									
98	TREASURER								
99	BUSINESS DATA OF VA, INC.	PROFESSIONAL SERVICES	CONSULTING	2020-1001	10/18/2017	10/20/2017	550.00		
100	CENTURYLINK	TELECOMMUNICATIONS	FINANCE	309762613 091617	10/4/2017	10/6/2017	20.25		
101	KODIAK, LLC.	LEASE/RENT	SHRED	64579	10/11/2017	10/13/2017	35.00		
102	MECHUMS RIVER SECURITY	LEASE/RENT	QUARTERLY MONITORING	8138	10/11/2017	10/13/2017	60.00		
103	STAPLES CONTRACT & COMMERCIAL, INC.	OFFICE SUPPLIES	SUPPLIES	8046663058	10/18/2017	10/20/2017	(\$139.99)		
104	STAPLES CONTRACT & COMMERCIAL, INC.	OFFICE SUPPLIES	SUPPLIES	8046663058	10/18/2017	10/20/2017	21.99		
105	STAPLES CONTRACT & COMMERCIAL, INC.	OFFICE SUPPLIES	SUPPLIES	8046663058	10/18/2017	10/20/2017	28.49		
106	STAPLES CONTRACT & COMMERCIAL, INC.	OFFICE SUPPLIES	SUPPLIES	8046663058	10/18/2017	10/20/2017	51.49		
107	STAPLES CONTRACT & COMMERCIAL, INC.	OFFICE SUPPLIES	SUPPLIES	8046663058	10/18/2017	10/20/2017	139.99		
108	STAPLES CONTRACT & COMMERCIAL, INC.	OFFICE SUPPLIES	SUPPLIES	8046663058	10/18/2017	10/20/2017	154.47		
109	THE SUPPLY ROOM	FURNITURE & FIXTURES	TREASURER FURNITURE	3070224-0	10/4/2017	10/6/2017	1,662.15		
110	THE SUPPLY ROOM	LEASE/RENT	COOLER RENTAL	3100027-0	10/18/2017	10/20/2017	9.99		
111	VERIZON	TELECOMMUNICATIONS	WIRELESS	9794804823	10/24/2017	10/27/2017	50.08		
112	VIRGINIA BUSINESS SYSTEMS	LEASE/RENT	COPIER	21393403	10/18/2017	10/20/2017	131.38		
113								Total:	\$2,775.29
114									
115	INFORMATION TECHNOLOGY								
116	BANK OF AMERICA	ADP SERVICES	P-CARD PURCHASES	093017	10/17/2017	10/20/2017	14.99		
117	BANK OF AMERICA	ADP SERVICES	P-CARD PURCHASES	093017	10/17/2017	10/20/2017	16.50		
118	BANK OF AMERICA	ADP SERVICES	P-CARD PURCHASES	093017	10/17/2017	10/20/2017	19.95		
119	BANK OF AMERICA	ADP SERVICES	P-CARD PURCHASES	093017	10/17/2017	10/20/2017	65.00		
120	BANK OF AMERICA	ADP SERVICES	P-CARD PURCHASES	093017	10/17/2017	10/20/2017	414.99		
121	BANK OF AMERICA	ADP SERVICES	P-CARD PURCHASES	093017	10/17/2017	10/20/2017	483.00		
122	BANK OF AMERICA	ADP SERVICES	P-CARD PURCHASES	093017	10/17/2017	10/20/2017	483.65		
123	BANK OF AMERICA	ADP SERVICES	P-CARD PURCHASES	093017	10/17/2017	10/20/2017	2,277.60		
124	BANK OF AMERICA	ADP SUPPLIES	P-CARD PURCHASES	093017	10/17/2017	10/20/2017	14.40		
125	BANK OF AMERICA	ADP SUPPLIES	P-CARD PURCHASES	093017	10/17/2017	10/20/2017	36.54		
126	BANK OF AMERICA	ADP SUPPLIES	P-CARD PURCHASES	093017	10/17/2017	10/20/2017	97.35		
127	BANK OF AMERICA	ADP SUPPLIES	P-CARD PURCHASES	093017	10/17/2017	10/20/2017	157.72		
128	BANK OF AMERICA	ADP SUPPLIES	P-CARD PURCHASES	093017	10/17/2017	10/20/2017	277.38		
129	BANK OF AMERICA	BOOKS/PUBLICATIONS	P-CARD PURCHASES	093017	10/17/2017	10/20/2017	79.10		
130	BANK OF AMERICA	DUES OR ASSOCIATION	P-CARD PURCHASES	093017	10/17/2017	10/20/2017	99.00		
131	BANK OF AMERICA	FURNITURE & FIXTURES	P-CARD PURCHASES	093017	10/17/2017	10/20/2017	147.41		
132	BANK OF AMERICA	OFFICE SUPPLIES	P-CARD PURCHASES	093017	10/17/2017	10/20/2017	20.99		



	A	B	C	D	F	G	H	J	
1	County of Fluvanna		From Date: 10/1/2017						
2	Accounts Payable List		To Date: 10/31/2017						
3									
4									
6	Vendor Name	Charge To	Description	Invoice Number	Invoice Date	Check Date	Check Amount		
133	BANK OF AMERICA	OFFICE SUPPLIES	P-CARD PURCHASES	093017	10/17/2017	10/20/2017	29.89		
134	BANK OF AMERICA	TELECOMMUNICATIONS	P-CARD PURCHASES	093017	10/17/2017	10/20/2017	166.50		
135	CDW GOVERNMENT, INC.	ADP SERVICES	ADP SUPPLIES	KGW8436	10/11/2017	10/13/2017	391.57		
136	CDW GOVERNMENT, INC.	EDP EQUIPMENT	APPLE IPAD	KGV9083	10/4/2017	10/6/2017	1,579.20		
137	CENTURYLINK	TELECOMMUNICATIONS	FINANCE	309762613 091617	10/4/2017	10/6/2017	6.75		
138	ER COMMUNICATIONS LLC	PROFESSIONAL SERVICES	MAINTENANCE	1032	10/24/2017	10/27/2017	65.00		
139	ER COMMUNICATIONS LLC	PROFESSIONAL SERVICES	MAINTENANCE	1033	10/24/2017	10/27/2017	106.25		
140	VERIZON	TELECOMMUNICATIONS	WIRELESS	9794804823	10/24/2017	10/27/2017	96.29		
141	VIRTRU CORPORATION	ADP SERVICES	ADP	INV00015763	10/11/2017	10/13/2017	739.00		
142								Total:	\$7,886.02
143									
144	FINANCE								
145	BANK OF AMERICA	OFFICE SUPPLIES	FY17 BANK OF AMERICA CHARGES	630171	6/30/2017	10/20/2017	110.98		
146	CENTURYLINK	TELECOMMUNICATIONS	FINANCE	309762613 091617	10/4/2017	10/6/2017	16.85		
147	THE SUPPLY ROOM	LEASE/RENT	5 GALLONS	3113628-0	10/24/2017	10/27/2017	14.97		
148	THE SUPPLY ROOM	OFFICE SUPPLIES	SUPPLIES	3097190-0	10/18/2017	10/20/2017	52.37		
149								Total:	\$195.17
150									
151	REGISTRAR/ELECTORAL BOARD								
152	ALC COPIES, INC.	OFFICE SUPPLIES	SUPPLIES	9241	10/11/2017	10/13/2017	183.95		
153	AUTOMATED OFFICE SYSTEMS	LEASE/RENT	COLOR PRINTER	078345	10/4/2017	10/6/2017	155.00		
154	BANK OF AMERICA	POSTAL SERVICES	P-CARD PURCHASES	093017	10/17/2017	10/20/2017	3.27		
155	BANK OF AMERICA	POSTAL SERVICES	P-CARD PURCHASES	093017	10/17/2017	10/20/2017	6.54		
156	BANK OF AMERICA	POSTAL SERVICES	P-CARD PURCHASES	093017	10/17/2017	10/20/2017	9.81		
157	BANK OF AMERICA	POSTAL SERVICES	P-CARD PURCHASES	093017	10/17/2017	10/20/2017	11.44		
158	BANK OF AMERICA	POSTAL SERVICES	P-CARD PURCHASES	093017	10/17/2017	10/20/2017	37.06		
159	VERIZON	TELECOMMUNICATIONS	WIRELESS	9794804823	10/24/2017	10/27/2017	50.08		
160								Total:	\$457.15
161									
162	HUMAN RESOURCES								
163	BANK OF AMERICA	EMPLOYEE RECOGNITION	P-CARD PURCHASES	093017	10/17/2017	10/20/2017	522.23		
164	CENTURYLINK	TELECOMMUNICATIONS	FINANCE	309762613 091617	10/4/2017	10/6/2017	3.38		
165	FERNANDO DIZON	EMPLOYEE RECOGNITION	EMPLOYEE DINNER	1	10/4/2017	10/6/2017	2,000.00		
166	FRONTRUNNER SIGN STUDIOS	EMPLOYEE RECOGNITION	PRIDE AWARDS 2017	26875	10/4/2017	10/6/2017	470.85		
167	MCLAUGHLIN YOUNG EMPLOYEE SERVICES	PROFESSIONAL SERVICES	EMPLOYEE ASSISTANCE PROGRAM	47151	10/18/2017	10/20/2017	251.22		
168	MCLAUGHLIN YOUNG EMPLOYEE SERVICES	PROFESSIONAL SERVICES	EMPLOYEE ASSISTANCE PROGRAM	47512	10/18/2017	10/20/2017	251.22		
169	MCLAUGHLIN YOUNG EMPLOYEE SERVICES	PROFESSIONAL SERVICES	EMPLOYEE ASSISTANCE PROGRAM	47651	10/18/2017	10/20/2017	251.22		
170	MCLAUGHLIN YOUNG EMPLOYEE SERVICES	PROFESSIONAL SERVICES	EMPLOYEE ASSISTANCE PROGRAM	47792	10/18/2017	10/20/2017	251.22		
171	MCLAUGHLIN YOUNG EMPLOYEE SERVICES	PROFESSIONAL SERVICES	EMPLOYEE ASSISTANCE PROGRAM	48062	10/18/2017	10/20/2017	251.22		
172	PIERCE GROUP BENEFITS	PROFESSIONAL SERVICES	BROKER FEE	16 FLUVANNA	10/11/2017	10/13/2017	1,203.00		
173	SAM'S CLUB	EMPLOYEE RECOGNITION	ACCT 6045002021679179	9179 101817	10/24/2017	10/27/2017	109.40		
174	STAPLES CONTRACT & COMMERCIAL, INC.	OFFICE SUPPLIES	SUPPLIES	8046663058	10/18/2017	10/20/2017	5.89		



	A	B	C	D	F	G	H	J	
1	County of Fluvanna		From Date: 10/1/2017						
2	Accounts Payable List		To Date: 10/31/2017						
3									
4									
6	Vendor Name	Charge To	Description	Invoice Number	Invoice Date	Check Date	Check Amount		
175	STAPLES CONTRACT & COMMERCIAL, INC.	OFFICE SUPPLIES	SUPPLIES	8046663058	10/18/2017	10/20/2017	19.75		
176	STAPLES CONTRACT & COMMERCIAL, INC.	OFFICE SUPPLIES	SUPPLIES	8046663058	10/18/2017	10/20/2017	81.00		
177	VIRGINIA BUSINESS SYSTEMS	LEASE/RENT	PRINTER	21362213	10/4/2017	10/6/2017	44.80		
178								Total:	\$5,716.40
179									
180	GENERAL DISTRICT COURT								
181	CENTURYLINK	TELECOMMUNICATIONS	DISTRICT COURT	309871364 091617	10/4/2017	10/6/2017	232.00		
182	CENTURYLINK	TELECOMMUNICATIONS	DISTRICT COURT	309871364 101617	10/24/2017	10/27/2017	232.51		
183	KODIAK, LLC.	LEASE/RENT	SHRED	64579	10/11/2017	10/13/2017	15.00		
184	PITNEY BOWES	MAINTENANCE CONTRACTS	LEASE CHARGES	3304296992	10/4/2017	10/6/2017	173.80		
185	THE SUPPLY ROOM	MAINTENANCE CONTRACTS	SPRING WATER	3069402-0	10/4/2017	10/6/2017	9.99		
186	THE SUPPLY ROOM	MAINTENANCE CONTRACTS	COOLER RENTAL	3100039-0	10/18/2017	10/20/2017	9.99		
187	VIRGINIA BUSINESS SYSTEMS	MAINTENANCE CONTRACTS	COPIER	21362215	10/4/2017	10/6/2017	162.38		
188								Total:	\$835.67
189									
190	COURT SERVICE UNIT								
191	CENTURYLINK	TELECOMMUNICATIONS	FINANCE	309762613 091617	10/4/2017	10/6/2017	13.50		
192	DENNIS CRONIN	MILEAGE ALLOWANCES	MILEAGE	0917	10/6/2017	10/6/2017	35.31		
193	POSTMASTER	POSTAL SERVICES	POSTAGE	100117	10/6/2017	10/6/2017	49.00		
194	THE SUPPLY ROOM	LEASE/RENT	SPRING WATER	3091936-0	10/4/2017	10/6/2017	19.96		
195								Total:	\$117.77
196									
197	CLERK OF THE CIRCUIT COURT								
198	CENTURYLINK	TELECOMMUNICATIONS	FINANCE	309762613 091617	10/4/2017	10/6/2017	27.01		
199	FLUVANNA CO CIRCUIT COURT	CONTRACT SERVICES	BANK SERVICE FEES	101017	10/11/2017	10/13/2017	69.63		
200	KODIAK, LLC.	LEASE/RENT	SHRED	64579	10/11/2017	10/13/2017	15.00		
201	LOGAN SYSTEMS, INC.	PROFESSIONAL SERVICES	CONTRACT	50211	10/18/2017	10/20/2017	2,541.67		
202	STAPLES CONTRACT & COMMERCIAL, INC.	OFFICE SUPPLIES	SUPPLIES	8046663058	10/18/2017	10/20/2017	14.95		
203	STAPLES CONTRACT & COMMERCIAL, INC.	OFFICE SUPPLIES	SUPPLIES	8046663058	10/18/2017	10/20/2017	265.00		
204	TREASURER OF VIRGINIA	EDP EQUIPMENT	COMPUTERS AND MONITORS	18-FLUPC-0234	10/24/2017	10/27/2017	418.03		
205	TRISTANA TREADWAY	CONVENTION AND	REIMBURSEMENT	092417	10/4/2017	10/6/2017	245.11		
206	TRISTANA TREADWAY	MILEAGE ALLOWANCES	REIMBURSEMENT	092417	10/4/2017	10/6/2017	146.80		
207	VIRGINIA BUSINESS SYSTEMS	LEASE/RENT	COPIER	21474020	10/24/2017	10/27/2017	223.33		
208								Total:	\$3,966.53
209									
210	CIRCUIT COURT JUDGE								
211	CENTURYLINK	TELECOMMUNICATIONS	FINANCE	309762613 091617	10/4/2017	10/6/2017	10.13		
212	CASSIE R. SMITH	COMPENSATION-GRAND	GRAND JURY 10/23/17	GJ102017-5	10/24/2017	10/27/2017	30.00		
213	HEATH CHRISTOPHER HUGHES	COMPENSATION-GRAND	GRAND JURY 10/23/17	GJ102017-4	10/24/2017	10/27/2017	30.00		
214	JANICE MARIE ALLEN	COMPENSATION-GRAND	GRAND JURY 10/23/17	GJ102017-1	10/24/2017	10/27/2017	30.00		
215	LOUISE TALLEY	COMPENSATION-GRAND	GRAND JURY 10/23/17	GJ102017-6	10/24/2017	10/27/2017	30.00		
216	RONALD GEORGE HARRIS	COMPENSATION-GRAND	GRAND JURY 10/23/17	GJ102017-3	10/24/2017	10/27/2017	30.00		

	A	B	C	D	F	G	H	J	
1	County of Fluvanna		From Date: 10/1/2017						
2	Accounts Payable List		To Date: 10/31/2017						
3									
4									
6	Vendor Name	Charge To	Description	Invoice Number	Invoice Date	Check Date	Check Amount		
217	SUSAN M. BOISVERT	COMPENSATION-GRAND	GRAND JURY 10/23/17	GJ102017-2	10/24/2017	10/27/2017	30.00		
218	TIMOTHY TERPILOWSKI	COMPENSATION-GRAND	GRAND JURY 10/23/17	GJ102017-7	10/24/2017	10/27/2017	30.00		
219	TREASURER OF VIRGINIA	EDP EQUIPMENT	COMPUTERS AND MONITORS	18-FLUPC-0234	10/24/2017	10/27/2017	526.97		
220								Total:	\$747.10
221									
222	COMMONWEALTH ATTY								
223	BANK OF AMERICA	BOOKS/PUBLICATIONS	P-CARD PURCHASES	093017	10/17/2017	10/20/2017	133.25		
224	BANK OF AMERICA	OTHER OPERATING	P-CARD PURCHASES	093017	10/17/2017	10/20/2017	77.21		
225	BLUE360 MDIA	BOOKS/PUBLICATIONS	LAW MANUALS	1286	10/11/2017	10/13/2017	120.50		
226	CENTURYLINK	TELECOMMUNICATIONS	FINANCE	309762613 091617	10/4/2017	10/6/2017	16.88		
227	COMPUTER PROJECTS OF ILLINOIS (CPI)	MAINTENANCE CONTRACTS	MESSANGER LICENSE AND MAINTENANCE	17-10-85-ME	10/24/2017	10/27/2017	173.40		
228	JEFF HAISLIP	CONVENTION AND	MILEAGE	092817	10/4/2017	10/6/2017	62.17		
229	MATTHEW BENDER & CO INC	MAINTENANCE CONTRACTS	SUBSCRIPTION	3091149140	10/4/2017	10/6/2017	130.00		
230	STAPLES CONTRACT & COMMERCIAL, INC.	OFFICE SUPPLIES	SUPPLIES	8046663058	10/18/2017	10/20/2017	22.70		
231	STAPLES CONTRACT & COMMERCIAL, INC.	OFFICE SUPPLIES	SUPPLIES	8046663058	10/18/2017	10/20/2017	76.17		
232	STAPLES CONTRACT & COMMERCIAL, INC.	OFFICE SUPPLIES	SUPPLIES	8046663058	10/18/2017	10/20/2017	129.99		
233	STAPLES CONTRACT & COMMERCIAL, INC.	OFFICE SUPPLIES	SUPPLIES	8046663058	10/18/2017	10/20/2017	169.99		
234	STAPLES CONTRACT & COMMERCIAL, INC.	OFFICE SUPPLIES	SUPPLIES	8046663058	10/18/2017	10/20/2017	171.90		
235	STAPLES CONTRACT & COMMERCIAL, INC.	OTHER OPERATING	SUPPLIES	8046663058	10/18/2017	10/20/2017	86.03		
236	STAPLES CONTRACT & COMMERCIAL, INC.	OTHER OPERATING	SUPPLIES	8046663058	10/18/2017	10/20/2017	347.44		
237	THE SUPPLY ROOM	LEASE/RENT	COOLER RENTAL	3100033-0	10/11/2017	10/13/2017	9.99		
238	TODD SHOCKLEY	CONVENTION AND	MILEAGE	100217	10/24/2017	10/27/2017	52.97		
239	VERIZON	TELECOMMUNICATIONS	WIRELESS	9794804823	10/24/2017	10/27/2017	50.08		
240								Total:	\$1,830.67
241									
242	SHERIFF								
243	ADVANCE AUTO PARTS	VEHICLE/POWER EQUIP	OIL FILTER	7306727264974	10/4/2017	10/6/2017	9.19		
244	ADVANCE AUTO PARTS	VEHICLE/POWER EQUIP	OIL FILTER	7306728356498	10/18/2017	10/20/2017	9.56		
245	ADVANCE AUTO PARTS	VEHICLE/POWER EQUIP	OIL FILTER	7306727956323	10/18/2017	10/20/2017	12.41		
246	ADVANCE AUTO PARTS	VEHICLE/POWER EQUIP	CAR SUPPLIES	7306729037102	10/18/2017	10/20/2017	36.01		
247	ADVANCE AUTO PARTS	VEHICLE/POWER EQUIP	OIL FILTER	7306729381218	10/24/2017	10/27/2017	9.19		
248	ADVANCE AUTO PARTS	VEHICLE/POWER EQUIP	OIL FILTER	7306729681271	10/24/2017	10/27/2017	9.56		
249	AT&T 286-3642	TELECOMMUNICATIONS	MONTHLY CHARGES	100617	10/24/2017	10/27/2017	78.09		
250	ATLANTIC TACTICAL	POLICE SUPPLIES	SUPPLIES	SI-80604756	10/18/2017	10/20/2017	484.96		
251	BANK OF AMERICA	OTHER OPERATING	P-CARD PURCHASES	093017	10/17/2017	10/20/2017	32.40		
252	BANK OF AMERICA	OTHER OPERATING	P-CARD PURCHASES	093017	10/17/2017	10/20/2017	44.72		
253	BANK OF AMERICA	POLICE SUPPLIES	P-CARD PURCHASES	093017	10/17/2017	10/20/2017	29.70		
254	BANK OF AMERICA	POLICE SUPPLIES	P-CARD PURCHASES	093017	10/17/2017	10/20/2017	124.18		
255	BANK OF AMERICA	POLICE SUPPLIES	P-CARD PURCHASES	093017	10/17/2017	10/20/2017	417.44		
256	BANK OF AMERICA	SUBSISTENCE & LODGING	P-CARD PURCHASES	093017	10/17/2017	10/20/2017	154.46		
257	BANK OF AMERICA	SUBSISTENCE & LODGING	P-CARD PURCHASES	093017	10/17/2017	10/20/2017	301.86		
258	BANK OF AMERICA	SUBSISTENCE & LODGING	P-CARD PURCHASES	093017	10/17/2017	10/20/2017	309.03		



	A	B	C	D	F	G	H	J
1	County of Fluvanna		From Date: 10/1/2017					
2	Accounts Payable List		To Date: 10/31/2017					
3								
4								
6	Vendor Name	Charge To	Description	Invoice Number	Invoice Date	Check Date	Check Amount	
259	BANK OF AMERICA	VEHICLES REP & MAINT	P-CARD PURCHASES	093017	10/17/2017	10/20/2017	16.00	
260	CAMPBELL EQUIPMENT, INC.	VEHICLES REP & MAINT	CAR MAINTENANCE	092917	10/11/2017	10/13/2017	44.00	
261	CAMPBELL EQUIPMENT, INC.	VEHICLES REP & MAINT	CAR MAINTENANCE	092917A	10/11/2017	10/13/2017	80.00	
262	CAMPBELL EQUIPMENT, INC.	VEHICLES REP & MAINT	MOUNT AND BALANCE	100617A	10/18/2017	10/20/2017	44.00	
263	CAMPBELL EQUIPMENT, INC.	VEHICLES REP & MAINT	MOUNT AND BALANCE	101217	10/18/2017	10/20/2017	84.00	
264	CAMPBELL EQUIPMENT, INC.	VEHICLES REP & MAINT	MOUNT AND BALANCE	100417	10/18/2017	10/20/2017	88.00	
265	CENTURYLINK	TELECOMMUNICATIONS	FINANCE	309762613 091617	10/4/2017	10/6/2017	27.01	
266	CENTURYLINK	TELECOMMUNICATIONS	SHERIFFS	310191749 091617	10/4/2017	10/6/2017	970.00	
267	CENTURYLINK	TELECOMMUNICATIONS	MONTHLY CHARGES	309903768 100717	10/24/2017	10/27/2017	148.02	
268	CLEAR COMMUNICATIONS AND	VEHICLES REP & MAINT	TUNING FORKS	113899	10/24/2017	10/27/2017	12.00	
269	DONNA'S NEEDLEWORK & CRAFT	UNIFORM/WEARING	REPAIR PATCH	092917	10/24/2017	10/27/2017	2.00	
270	DUKE'S TOWING LLC	VEHICLES REP & MAINT	TOWING	18281	10/18/2017	10/20/2017	261.00	
271	E.W. THOMAS	OTHER OPERATING	INMATE'S MEAL	101017	10/18/2017	10/20/2017	26.54	
272	E.W. THOMAS	OTHER OPERATING	SR LUNCHEON	101017A	10/18/2017	10/20/2017	527.86	
273	EVIDENT CRIME SCENE PRODUCTS	POLICE SUPPLIES	SUPPLIES	124697A	10/24/2017	10/27/2017	66.90	
274	GALLS, LLC.	POLICE SUPPLIES	SUPPLIES	008482612	10/24/2017	10/27/2017	79.81	
275	GALLS, LLC.	UNIFORM/WEARING	UNIFORM	008394948	10/18/2017	10/20/2017	105.86	
276	GALLS, LLC.	UNIFORM/WEARING	UNIFORM	008425732	10/18/2017	10/20/2017	113.14	
277	JAMES RIVER SOLUTIONS	VEHICLE FUEL	FUEL	100217	10/11/2017	10/13/2017	4,887.95	
278	JONES AUTOMOTIVE/ALL STAR AUTO PARTS	VEHICLES REP & MAINT	CAR SUPPLIES	577962	10/11/2017	10/13/2017	93.26	
279	KODIAK, LLC.	LEASE/RENT	SHRED	64579	10/11/2017	10/13/2017	35.00	
280	KUSTOM SIGNALS, INC.	VEHICLES REP & MAINT	MAINTENANCE	545620	10/4/2017	10/6/2017	396.90	
281	KUSTOM SIGNALS, INC.	VEHICLES REP & MAINT	MAINTENANCE	545621	10/4/2017	10/6/2017	396.90	
282	KUSTOM SIGNALS, INC.	VEHICLES REP & MAINT	MAINTENANCE	545622	10/4/2017	10/6/2017	396.90	
283	KUSTOM SIGNALS, INC.	VEHICLES REP & MAINT	MAINTENANCE	545619	10/4/2017	10/6/2017	397.30	
284	LEATHAM FAMILY LLC	UNIFORM/WEARING	UNIFORM SUPPLIES	0291314-IN	10/4/2017	10/6/2017	1,370.00	
285	MANSFIELD OIL COMPANY OF GAINESVILLE,	VEHICLE FUEL	FUEL	SQLCD/356406	10/4/2017	10/6/2017	188.42	
286	MANSFIELD OIL COMPANY OF GAINESVILLE,	VEHICLE FUEL	FUEL	SQLCD/361238	10/24/2017	10/27/2017	171.52	
287	TOBEY'S PAWN	INVESTIGATIVE SERVICES	INVESTIGATION	TP01	10/4/2017	10/6/2017	15.00	
288	PALMYRA AUTOMOTIVE, INC.	VEHICLES REP & MAINT	CAR MAINTENANCE	68658	10/18/2017	10/20/2017	14.00	
289	PALMYRA AUTOMOTIVE, INC.	VEHICLES REP & MAINT	MOTORCYCLE MAINTENANCE	68845	10/24/2017	10/27/2017	12.00	
290	POSITIVE PROMOTIONS, INC.	COMMUNITY EDUCATION	SUPPLIES	05873311	10/18/2017	10/20/2017	768.33	
291	SHERIDAN FUNERAL HOME, INC.	PROFESSIONAL SERVICES	UNCLAIMED BODY	SFH01	10/4/2017	10/6/2017	1,500.00	
292	SHULL'S AUTOMOTIVE, INC.	VEHICLE/POWER EQUIP	CAR MAINTENANCE	1001822	10/18/2017	10/20/2017	16.00	
293	SHULL'S AUTOMOTIVE, INC.	VEHICLES REP & MAINT	TOWING	100217	10/4/2017	10/6/2017	85.00	
294	SHULL'S AUTOMOTIVE, INC.	VEHICLES REP & MAINT	OIL CHANGE	1001823	10/18/2017	10/20/2017	14.00	
295	SHULL'S AUTOMOTIVE, INC.	VEHICLES REP & MAINT	OIL CHANGE	1001821	10/18/2017	10/20/2017	34.00	
296	STAPLES CONTRACT & COMMERCIAL, INC.	FURNITURE & FIXTURES	SUPPLIES	8046663058	10/18/2017	10/20/2017	173.92	
297	STAPLES CONTRACT & COMMERCIAL, INC.	OFFICE SUPPLIES	SUPPLIES	8046663058	10/18/2017	10/20/2017	3.10	
298	STAPLES CONTRACT & COMMERCIAL, INC.	OFFICE SUPPLIES	SUPPLIES	8046663058	10/18/2017	10/20/2017	6.20	
299	STAPLES CONTRACT & COMMERCIAL, INC.	OFFICE SUPPLIES	SUPPLIES	8046663058	10/18/2017	10/20/2017	16.61	
300	STAPLES CONTRACT & COMMERCIAL, INC.	OFFICE SUPPLIES	SUPPLIES	8046663058	10/18/2017	10/20/2017	64.22	



	A	B	C	D	F	G	H	J	
1	County of Fluvanna		From Date: 10/1/2017						
2	Accounts Payable List		To Date: 10/31/2017						
3									
4									
6	Vendor Name	Charge To	Description	Invoice Number	Invoice Date	Check Date	Check Amount		
301	STAPLES CONTRACT & COMMERCIAL, INC.	OFFICE SUPPLIES	SUPPLIES	8046663058	10/18/2017	10/20/2017	101.00		
302	STAPLES CONTRACT & COMMERCIAL, INC.	OFFICE SUPPLIES	SUPPLIES	8046663058	10/18/2017	10/20/2017	142.17		
303	STAPLES CONTRACT & COMMERCIAL, INC.	OFFICE SUPPLIES	SUPPLIES	8046663058	10/18/2017	10/20/2017	167.40		
304	THE SUPPLY ROOM	FOOD SUPPLIES	5 GALLONS	3091918-0	10/4/2017	10/6/2017	64.87		
305	THE SUPPLY ROOM	FOOD SUPPLIES	COOLER RENTAL	3100026-0	10/18/2017	10/20/2017	29.97		
306	VACORP	WORKER'S COMPENSATION	WORKERS COMP	14293	6/30/2017	10/26/2017	2,922.00		
307	VALLEY OFFICE MACHINES, INC.	LEASE/RENT	COLOR COPIER	171006-0006	10/18/2017	10/20/2017	36.74		
308	VALLEY OFFICE MACHINES, INC.	LEASE/RENT	COPIER	171006-0007	10/18/2017	10/20/2017	55.99		
309	VERIZON	TELECOMMUNICATIONS	SHERIFF OFFICE	9794147780	10/18/2017	10/20/2017	1,897.33		
310	VIRGINIA BUSINESS SYSTEMS	LEASE/RENT	COPIER	21400765	10/18/2017	10/20/2017	77.72		
311	VIRGINIA SHERIFF'S ASSOCIATION	DUES OR ASSOCIATION	DUES	201855	10/4/2017	10/6/2017	1,695.00		
312	VLEPSC TREASURER	DUES OR ASSOCIATION	APP FEE	10-06-2017A	10/18/2017	10/20/2017	250.00		
313	WELLS FARGO VENDOR FIN SERV	LEASE/RENT	COPIER	67614259	10/18/2017	10/20/2017	289.90		
314	WEST RIVER AUTO	VEHICLES REP & MAINT	CAR MAINTENANCE	34245	10/18/2017	10/20/2017	22.53		
315	WEST RIVER AUTO	VEHICLES REP & MAINT	CAR MAINTENANCE	34292	10/18/2017	10/20/2017	36.65		
316							Total:	\$23,604.70	
317									
318	E911								
319	ALBEMARLE LOCK & SAFE, INC.	BLDGS EQUIP REP & MAINT	KEY CODE	69167	10/18/2017	10/20/2017	42.65		
320	BANK OF AMERICA	CONVENTION AND	P-CARD PURCHASES	093017	10/17/2017	10/20/2017	250.00		
321	BANK OF AMERICA	MAINTENANCE CONTRACTS	P-CARD PURCHASES	093017	10/17/2017	10/20/2017	20.00		
322	BANK OF AMERICA	MAINTENANCE CONTRACTS	P-CARD PURCHASES	093017	10/17/2017	10/20/2017	228.00		
323	CENTURYLINK	TELECOMMUNICATIONS	FINANCE	309762613 091617	10/4/2017	10/6/2017	3.38		
324	CENTURYLINK	TELECOMMUNICATIONS	WIRELINE	310042302 091017	10/4/2017	10/6/2017	1,665.00		
325	CENTURYLINK	TELECOMMUNICATIONS	E911	310214091 091917	10/4/2017	10/6/2017	1,921.60		
326	CENTURYLINK	TELECOMMUNICATIONS	WIRELINE	310042302 101017	10/24/2017	10/27/2017	1,665.00		
327	COMCAST CORPORATION	TELECOMMUNICATIONS	MONTHLY CHARGES	46933 100317	10/18/2017	10/20/2017	76.82		
328	EVERBRIDGE INC	MAINTENANCE CONTRACTS	EMERGENCY ALERT	M34801	10/18/2017	10/20/2017	8,975.37		
329	JOEL A. ZELINSKY	E911 NEW ROAD SIGNS	ADDRESS PLATES	3035	10/4/2017	10/6/2017	800.15		
330	NWG SOLUTIONS, LLC.	IT SERVICES	MANAGED SERVICES	41988	10/4/2017	10/6/2017	875.00		
331	NWG SOLUTIONS, LLC.	IT SERVICES	BLOCK TIME	42186	10/18/2017	10/20/2017	2,500.00		
332	NWG SOLUTIONS, LLC.	IT SERVICES	BLOCK TIME	42201	10/18/2017	10/20/2017	2,500.00		
333	NWG SOLUTIONS, LLC.	MAINTENANCE CONTRACTS	DATTO	41984	10/4/2017	10/6/2017	1,103.70		
334	VERIZON	TELECOMMUNICATIONS	SHERIFF OFFICE	9794147780	10/18/2017	10/20/2017	330.35		
335	VIRGINIA BUSINESS SYSTEMS	LEASE/RENT	COPIER	21400765	10/18/2017	10/20/2017	77.73		
336							Total:	\$23,034.75	
337									
338	FIRE AND RESCUE SQUAD								
339	CNA INSURANCE COMPANIES	F&R WORKERS	POLICY 5B485297	8992P0165 71516	9/18/2017	10/6/2017	412.00		
340	CONTAINER RENTALS, LLC.	CONVENTION AND	TRAINING EXPENSE	206742	8/31/2017	10/6/2017	1,891.00		
341	FLUVANNA COUNTY RESCUE SQUAD	FIRE & RESCUE ASSN	QUARTERLY ALLOCATION	FR2 17	10/4/2017	10/6/2017	24,250.00		
342	FLUVANNA COUNTY VOLUNTEER FIRE	FIRE & RESCUE ASSN	QUARTERLY	FF2 17	10/4/2017	10/6/2017	29,928.75		

	A	B	C	D	F	G	H	J	
1	County of Fluvanna		From Date: 10/1/2017						
2	Accounts Payable List		To Date: 10/31/2017						
3									
4									
6	Vendor Name	Charge To	Description	Invoice Number	Invoice Date	Check Date	Check Amount		
343	LAKE MONTICELLO FIRE & RESCUE	FIRE & RESCUE ASSN	RESCUE QUARTERLY	LM2 17	10/4/2017	10/6/2017	67,500.00		
344	LAKE MONTICELLO FIRE & RESCUE	FIRE & RESCUE CAPITAL	RESCUE QUARTERLY	LM2 17	10/4/2017	10/6/2017	55,000.00		
345	STAPLES CONTRACT & COMMERCIAL, INC.	CONVENTION AND	SUPPLIES	8046663058	10/18/2017	10/20/2017	417.65		
346								Total:	\$179,399.40
347									
348	BUILDING INSPECTIONS								
349	CENTURYLINK	TELECOMMUNICATIONS	FINANCE	309762613 091617	10/4/2017	10/6/2017	10.13		
350	JAMES RIVER SOLUTIONS	VEHICLE FUEL	FUEL	100217	10/11/2017	10/13/2017	39.81		
351	MANSFIELD OIL COMPANY OF GAINESVILLE,	VEHICLE FUEL	FUEL	SQLCD/356406	10/4/2017	10/6/2017	32.22		
352	STAPLES CONTRACT & COMMERCIAL, INC.	OFFICE SUPPLIES	SUPPLIES	8046663058	10/18/2017	10/20/2017	39.98		
353	STAPLES CONTRACT & COMMERCIAL, INC.	OFFICE SUPPLIES	SUPPLIES	8046663058	10/18/2017	10/20/2017	81.73		
354	TREASURER OF VIRGINIA	SURCHARGE	PERMIT FEES	LV201801	10/11/2017	10/13/2017	593.57		
355	VERIZON	TELECOMMUNICATIONS	WIRELESS	9794804823	10/24/2017	10/27/2017	100.16		
356								Total:	\$897.60
357									
358	EMERGENCY MANAGEMENT								
359	CENTURYLINK	TELECOMMUNICATIONS	FINANCE	309762613 091617	10/4/2017	10/6/2017	3.38		
360	EMS MANAGEMENT & CONSULTANTS, INC	CONTRACT SERVICES	NPP LETTERS MAILED	031539	10/11/2017	10/13/2017	1,475.51		
361	RECTOR & VISITORS OF THE UNIVERSITY OF	CONTRACT SERVICES	SEPT EMS COVERAGE	093017	10/24/2017	10/27/2017	48,713.12		
362	STAPLES CONTRACT & COMMERCIAL, INC.	OFFICE SUPPLIES	SUPPLIES	8046663058	10/18/2017	10/20/2017	258.38		
363								Total:	\$50,450.39
364									
365	ANIMAL CONTROL								
366	BANK OF AMERICA	AGRICULTURAL SUPPLIES	P-CARD PURCHASES	093017	10/17/2017	10/20/2017	75.83		
367	BANK OF AMERICA	AGRICULTURAL SUPPLIES	P-CARD PURCHASES	093017	10/17/2017	10/20/2017	316.19		
368	FLUVANNA SPCA	CONTRACT SERVICES	POUND SERVICES 2ND QTR OCT-DEC	100117	10/4/2017	10/6/2017	38,536.50		
369	JAMES RIVER SOLUTIONS	VEHICLE FUEL	FUEL	100217	10/11/2017	10/13/2017	410.98		
370	VERIZON	TELECOMMUNICATIONS	SHERIFF OFFICE	9794147780	10/18/2017	10/20/2017	180.18		
371								Total:	\$39,519.68
372									
373	FACILITIES								
374	BANK OF AMERICA	BLDGS EQUIP REP & MAINT	P-CARD PURCHASES	093017	10/17/2017	10/20/2017	(\$25.21)		
375	BANK OF AMERICA	BLDGS EQUIP REP & MAINT	P-CARD PURCHASES	093017	10/17/2017	10/20/2017	25.21		
376	BANK OF AMERICA	BLDGS EQUIP REP & MAINT	P-CARD PURCHASES	093017	10/17/2017	10/20/2017	29.99		
377	BANK OF AMERICA	GENERAL MATERIALS AND	P-CARD PURCHASES	093017	10/17/2017	10/20/2017	10.90		
378	BANK OF AMERICA	GENERAL MATERIALS AND	P-CARD PURCHASES	093017	10/17/2017	10/20/2017	16.99		
379	BANK OF AMERICA	GENERAL MATERIALS AND	P-CARD PURCHASES	093017	10/17/2017	10/20/2017	50.84		
380	BANK OF AMERICA	GENERAL MATERIALS AND	P-CARD PURCHASES	093017	10/17/2017	10/20/2017	51.35		
381	BANK OF AMERICA	GENERAL MATERIALS AND	P-CARD PURCHASES	093017	10/17/2017	10/20/2017	52.78		
382	BANK OF AMERICA	GENERAL MATERIALS AND	P-CARD PURCHASES	093017	10/17/2017	10/20/2017	64.47		
383	BANK OF AMERICA	GENERAL MATERIALS AND	P-CARD PURCHASES	093017	10/17/2017	10/20/2017	75.21		
384	BANK OF AMERICA	GENERAL MATERIALS AND	P-CARD PURCHASES	093017	10/17/2017	10/20/2017	99.25		



	A	B	C	D	F	G	H	J
1	County of Fluvanna		From Date: 10/1/2017					
2	Accounts Payable List		To Date: 10/31/2017					
3								
4								
6	Vendor Name	Charge To	Description	Invoice Number	Invoice Date	Check Date	Check Amount	
385	BANK OF AMERICA	GENERAL MATERIALS AND	P-CARD PURCHASES	093017	10/17/2017	10/20/2017	164.21	
386	BANK OF AMERICA	OFFICE SUPPLIES	FY17 BANK OF AMERICA CHARGES	630171	6/30/2017	10/20/2017	64.90	
387	BANK OF AMERICA	POSTAL SERVICES	P-CARD PURCHASES	093017	10/17/2017	10/20/2017	60.00	
388	BANK OF AMERICA	SUBSISTENCE & LODGING	P-CARD PURCHASES	093017	10/17/2017	10/20/2017	165.59	
389	BANK OF AMERICA	VEHICLE FUEL	P-CARD PURCHASES	093017	10/17/2017	10/20/2017	21.81	
390	BROWN MOTOR PARTS, INC.	VEHICLES REP & MAINT	CAR PARTS	ID-85024 85077	10/11/2017	10/13/2017	96.97	
391	BUDGET ELECTRICAL & MECHANICAL, LLC.	GENERAL MATERIALS AND	SUPPLIES	0925	10/4/2017	10/6/2017	490.00	
392	CAMPBELL EQUIPMENT, INC.	VEHICLES REP & MAINT	CAR MAINTENANCE	100317	10/11/2017	10/13/2017	21.00	
393	CAMPBELL EQUIPMENT, INC.	VEHICLES REP & MAINT	CAR MAINTENANCE	100617	10/11/2017	10/13/2017	707.96	
394	CARROT-TOP INDUSTRIES, INC.	GENERAL MATERIALS AND	SUPPLIES	35767800	10/18/2017	10/20/2017	788.01	
395	CENTURYLINK	TELECOMMUNICATIONS	FINANCE	309762613 091617	10/4/2017	10/6/2017	13.50	
396	CII SERVICE	BLDGS EQUIP REP & MAINT	WO# 3598	42024	10/4/2017	10/6/2017	234.70	
397	CII SERVICE	BLDGS EQUIP REP & MAINT	WO# 3594	42023	10/4/2017	10/6/2017	976.91	
398	CII SERVICE	BLDGS EQUIP REP & MAINT	WO# 3478	42056	10/11/2017	10/13/2017	545.06	
399	CII SERVICE	BLDGS EQUIP REP & MAINT	WO# 3476	42055	10/11/2017	10/13/2017	578.58	
400	CII SERVICE	BLDGS EQUIP REP & MAINT	WO# 3446	42053	10/11/2017	10/13/2017	662.55	
401	CII SERVICE	BLDGS EQUIP REP & MAINT	WO# 3475	42054	10/11/2017	10/13/2017	903.34	
402	CII SERVICE	BLDGS EQUIP REP & MAINT	WO# 3600	42111	10/18/2017	10/20/2017	456.57	
403	CII SERVICE	BLDGS EQUIP REP & MAINT	WO# 3474	42098	10/18/2017	10/20/2017	7,831.37	
404	CINTAS	LAUNDRY AND DRY	DRY CLEANING	394147035	10/4/2017	10/6/2017	275.43	
405	CINTAS	LAUNDRY AND DRY	DRY CLEANING	394149070	10/11/2017	10/13/2017	123.38	
406	CINTAS	LAUNDRY AND DRY	DRY CLEANING	394151026	10/18/2017	10/20/2017	123.60	
407	CINTAS	LAUNDRY AND DRY	DRY CLEANING	394153007	10/24/2017	10/27/2017	133.90	
408	CINTAS	LAUNDRY AND DRY	DRY CLEANING	394151027	10/24/2017	10/27/2017	181.65	
409	COMMONWEALTH DISTRIBUTION, LLC.	JANITORIAL SUPPLIES	SUPPLIES	64136	10/4/2017	10/6/2017	246.59	
410	COMMONWEALTH INTERIORS	BLDGS EQUIP REP & MAINT	REPAIRS	2017-196	10/4/2017	10/6/2017	226.00	
411	COMMONWEALTH INTERIORS	BLDGS EQUIP REP & MAINT	NEW CARPET	2017-205	10/18/2017	10/20/2017	1,154.00	
412	COSTEN FLOORS INC	BLDGS EQUIP REP & MAINT	STAGE FLOOR	CG703164	10/18/2017	10/20/2017	1,782.00	
413	DAVID W. GOURLEY	BLDGS EQUIP REP & MAINT	REPAIRS	100317	10/11/2017	10/13/2017	1,188.00	
414	E.W. THOMAS	GENERAL MATERIALS AND	SUPPLIES	080117	10/11/2017	10/13/2017	59.98	
415	E.W. THOMAS	GENERAL MATERIALS AND	SUPPLIES	090117	10/11/2017	10/13/2017	69.07	
416	E.W. THOMAS	JANITORIAL SUPPLIES	SUPPLIES	080117	10/11/2017	10/13/2017	11.94	
417	E.W. THOMAS	JANITORIAL SUPPLIES	SUPPLIES	090117	10/11/2017	10/13/2017	36.70	
418	FLUVANNA ACE HARDWARE	GENERAL MATERIALS AND	SUPPLIES	63014	10/11/2017	10/13/2017	124.92	
419	GARDENKEEPERS OF VIRGINIA, LLC.	CONTRACT SERVICES	COLUMBIA/CUNNINGHAM LAWN WORK	8049	10/11/2017	10/13/2017	780.00	
420	GARDNER SHOES CHARLOTTESVILLE LLC	GENERAL MATERIALS AND	SUPPLIES	05132548	10/11/2017	10/13/2017	199.19	
421	GARY OSTEEN PLUMBING	BLDGS EQUIP REP & MAINT	COMMERCIAL KITCHEN	082917B	10/4/2017	10/6/2017	648.00	
422	GARY OSTEEN PLUMBING	BLDGS EQUIP REP & MAINT	REPAIRS	082317	10/4/2017	10/6/2017	1,600.00	
423	GARY OSTEEN PLUMBING	BLDGS EQUIP REP & MAINT	REPAIRS	102417	10/24/2017	10/27/2017	1,076.34	
424	JAMES RIVER SOLUTIONS	VEHICLE FUEL	FUEL	100217	10/11/2017	10/13/2017	1,580.32	
425	JONES AUTOMOTIVE/ALL STAR AUTO PARTS	GENERAL MATERIALS AND	CAR PARTS	100117	10/11/2017	10/13/2017	99.46	
426	JONES AUTOMOTIVE/ALL STAR AUTO PARTS	VEHICLE/POWER EQUIP	CAR PARTS	100117	10/11/2017	10/13/2017	327.03	



	A	B	C	D	F	G	H	J	
1	County of Fluvanna		From Date: 10/1/2017						
2	Accounts Payable List		To Date: 10/31/2017						
3									
4									
6	Vendor Name	Charge To	Description	Invoice Number	Invoice Date	Check Date	Check Amount		
427	JONES AUTOMOTIVE/ALL STAR AUTO PARTS	VEHICLES REP & MAINT	CAR PARTS	100117	10/11/2017	10/13/2017	700.29		
428	LOWE'S	GENERAL MATERIALS AND	SUPPLIES	092517	10/4/2017	10/6/2017	707.78		
429	LOWE'S	JANITORIAL SUPPLIES	SUPPLIES	092517	10/4/2017	10/6/2017	134.58		
430	LOWE'S	VEHICLES REP & MAINT	SUPPLIES	092517	10/4/2017	10/6/2017	614.65		
431	MAC'S SERVICE CENTER	VEHICLES REP & MAINT	STATE INSPECTION	0029161	10/4/2017	10/6/2017	16.00		
432	MAC'S SERVICE CENTER	VEHICLES REP & MAINT	STATE INSPECTION	0031688	10/4/2017	10/6/2017	16.00		
433	MAC'S SERVICE CENTER	VEHICLES REP & MAINT	CAR MAINTENANCE	0031330	10/4/2017	10/6/2017	49.44		
434	MAC'S SERVICE CENTER	VEHICLES REP & MAINT	CAR MAINTENANCE	0031560	10/4/2017	10/6/2017	73.69		
435	MAC'S SERVICE CENTER	VEHICLES REP & MAINT	CAR MAINTENANCE	0032332	10/4/2017	10/6/2017	1,582.11		
436	MAC'S SERVICE CENTER	VEHICLES REP & MAINT	CAR MAINTENANCE	0032499	10/11/2017	10/13/2017	107.95		
437	MAC'S SERVICE CENTER	VEHICLES REP & MAINT	CAR MAINTENANCE	0032429	10/11/2017	10/13/2017	189.52		
438	MAC'S SERVICE CENTER	VEHICLES REP & MAINT	CAR MAINTENANCE	0032426	10/11/2017	10/13/2017	259.35		
439	MJC DESIGNS, LLC.	GENERAL MATERIALS AND	CUSTOM DECAL	2580	10/24/2017	10/27/2017	45.00		
440	QUALITY WELDING, INC	GENERAL MATERIALS AND	SUPPLIES	40694	10/24/2017	10/27/2017	166.63		
441	RAFALY ELECTRICAL CONTRACTORS, INC.	BLDGS EQUIP REP & MAINT	REPAIRS	7518	10/11/2017	10/13/2017	112.00		
442	RAFALY ELECTRICAL CONTRACTORS, INC.	BLDGS EQUIP REP & MAINT	REPAIRS	7520	10/11/2017	10/13/2017	155.00		
443	RAFALY ELECTRICAL CONTRACTORS, INC.	BLDGS EQUIP REP & MAINT	REPAIRS	7517	10/11/2017	10/13/2017	357.50		
444	RAFALY ELECTRICAL CONTRACTORS, INC.	BLDGS EQUIP REP & MAINT	ADD NEW OUTLETS	7519	10/11/2017	10/13/2017	935.00		
445	THE SUPPLY ROOM	GENERAL MATERIALS AND	SUPPLIES	3081655-0	10/18/2017	10/20/2017	78.22		
446	TRACTOR HILL EQUIPMENT, LLC.	VEHICLE/POWER EQUIP	EQUIPMENT	47945	10/4/2017	10/6/2017	2,729.07		
447	USABLUEBOOK	GENERAL MATERIALS AND	SUPPLIES	373352	10/4/2017	10/6/2017	46.90		
448	USABLUEBOOK	GENERAL MATERIALS AND	SUPPLIES	378529	10/11/2017	10/13/2017	136.62		
449	VERIZON	TELECOMMUNICATIONS	WIRELESS	9794804823	10/24/2017	10/27/2017	681.54		
450	W.W. GRAINGER INC	GENERAL MATERIALS AND	SUPPLIES	9570615576	10/11/2017	10/13/2017	16.45		
451	W.W. GRAINGER INC	GENERAL MATERIALS AND	SUPPLIES	9570615568	10/11/2017	10/13/2017	32.91		
452	WAYNE OXYGEN & WELDING SUPPLY CO. INC	CONTRACT SERVICES	MATERIALS	65352G	10/4/2017	10/6/2017	20.02		
453							Total:	\$37,246.53	
454									
455	GENERAL SERVICES								
456	AMELIA OVERHEAD DOOR	MAINTENANCE CONTRACTS	REPAIRS	115089	10/11/2017	10/13/2017	100.00		
457	AMELIA OVERHEAD DOOR	MAINTENANCE CONTRACTS	REPAIRS	115090	10/11/2017	10/13/2017	100.00		
458	AMELIA OVERHEAD DOOR	MAINTENANCE CONTRACTS	MAINTENANCE	115093	10/11/2017	10/13/2017	200.00		
459	AMELIA OVERHEAD DOOR	MAINTENANCE CONTRACTS	MAINTENANCE	115087	10/11/2017	10/13/2017	300.00		
460	AMELIA OVERHEAD DOOR	MAINTENANCE CONTRACTS	MAINTENANCE	115091	10/11/2017	10/13/2017	300.00		
461	AMELIA OVERHEAD DOOR	MAINTENANCE CONTRACTS	MAINTENANCE	115088	10/11/2017	10/13/2017	600.00		
462	AMELIA OVERHEAD DOOR	MAINTENANCE CONTRACTS	MAINTENANCE	115092	10/11/2017	10/13/2017	600.00		
463	AMELIA OVERHEAD DOOR	MAINTENANCE CONTRACTS	MAINTENANCE	115094	10/11/2017	10/13/2017	600.00		
464	AQUA VIRGINIA, INC.	WATER SERVICES	MONTHLY CHARGES	7970740556855 100417	10/11/2017	10/13/2017	20.61		
465	AQUA VIRGINIA, INC.	WATER SERVICES	MONTHLY CHARGES	7929310552932 100417	10/11/2017	10/13/2017	21.36		
466	AQUA VIRGINIA, INC.	WATER SERVICES	MONTHLY CHARGES	15301850550900 10417	10/11/2017	10/13/2017	22.86		
467	AQUA VIRGINIA, INC.	WATER SERVICES	MONTHLY CHARGES	7929300552931 100417	10/11/2017	10/13/2017	60.26		
468	AQUA VIRGINIA, INC.	WATER SERVICES	MONTHLY CHARGES	7800100540828 100417	10/11/2017	10/13/2017	87.74		

	A	B	C	D	F	G	H	J
1	County of Fluvanna		From Date: 10/1/2017					
2	Accounts Payable List		To Date: 10/31/2017					
3								
4								
6	Vendor Name	Charge To	Description	Invoice Number	Invoice Date	Check Date	Check Amount	
469	BFPE INTERNATIONAL	MAINTENANCE CONTRACTS	INSPECTION	2131939	10/11/2017	10/13/2017	475.00	
470	CENTRAL VA ELECTRIC COOP	ELECTRICAL SERVICES	51 KENTS STORE	275907-002 100417	10/11/2017	10/13/2017	367.57	
471	CENTRAL VA ELECTRIC COOP	ELECTRICAL SERVICES	479 CUNNINGHAM RD	2133-005 092917	10/11/2017	10/13/2017	612.21	
472	CENTRAL VA ELECTRIC COOP	ELECTRICAL SERVICES	214 COMMONS BLVD	275906-001 092917	10/11/2017	10/13/2017	1,255.80	
473	CENTRAL VA ELECTRIC COOP	ELECTRICAL SERVICES	160 COMMONS BLVD	85473-002 092917	10/11/2017	10/13/2017	2,012.95	
474	CENTRAL VA ELECTRIC COOP	ELECTRICAL SERVICES	PLEASANT GR	105221-006 101817	10/24/2017	10/27/2017	28.39	
475	CENTRAL VA ELECTRIC COOP	ELECTRICAL SERVICES	479 CUNNINGHAM RD	2133-003 101817	10/24/2017	10/27/2017	28.39	
476	CENTRAL VA ELECTRIC COOP	ELECTRICAL SERVICES	563 WILMINGTON RD	85473-004 101817	10/24/2017	10/27/2017	28.39	
477	CENTRAL VA ELECTRIC COOP	ELECTRICAL SERVICES	718 THOMAS JEFF PKWY	85473-003 101817	10/24/2017	10/27/2017	28.78	
478	CENTRAL VA ELECTRIC COOP	ELECTRICAL SERVICES	THOMAS JEFF PKWY	105221-009 101817	10/24/2017	10/27/2017	30.39	
479	CENTRAL VA ELECTRIC COOP	ELECTRICAL SERVICES	THOMAS JEFF PKWY	105221-002 101817	10/24/2017	10/27/2017	30.98	
480	CENTRAL VA ELECTRIC COOP	ELECTRICAL SERVICES	271 PLEASANT GR DR	105221-008 101817	10/24/2017	10/27/2017	31.44	
481	CENTRAL VA ELECTRIC COOP	ELECTRICAL SERVICES	271 PLEASANT GR DR	275904-006 101817	10/24/2017	10/27/2017	31.72	
482	CENTRAL VA ELECTRIC COOP	ELECTRICAL SERVICES	THOMAS JEFF PKWY	105221-003 101817	10/24/2017	10/27/2017	32.28	
483	CENTRAL VA ELECTRIC COOP	ELECTRICAL SERVICES	271 PLEASANT GR DR	105221-007 101817	10/24/2017	10/27/2017	32.74	
484	CENTRAL VA ELECTRIC COOP	ELECTRICAL SERVICES	W RIVER RD	275904-008 101817	10/24/2017	10/27/2017	42.34	
485	CENTRAL VA ELECTRIC COOP	ELECTRICAL SERVICES	COMPETITION PK RD	105221-004 101817	10/24/2017	10/27/2017	49.33	
486	CENTRAL VA ELECTRIC COOP	ELECTRICAL SERVICES	11206 W RIVER RD	27590-002 101817	10/24/2017	10/27/2017	116.85	
487	CENTRAL VA ELECTRIC COOP	ELECTRICAL SERVICES	COMPETITION PK RD	105221-001 101817	10/24/2017	10/27/2017	143.08	
488	CENTRAL VA ELECTRIC COOP	ELECTRICAL SERVICES	2977 W RIVER RD	275904-010 101817	10/24/2017	10/27/2017	155.92	
489	CENTRAL VA ELECTRIC COOP	ELECTRICAL SERVICES	11206 W RIVER RD	85473-005 101817	10/24/2017	10/27/2017	190.59	
490	CENTRAL VA ELECTRIC COOP	ELECTRICAL SERVICES	563 WILMINGTON RD	85473-006 101817	10/24/2017	10/27/2017	191.29	
491	CENTRAL VA ELECTRIC COOP	ELECTRICAL SERVICES	271 PLEASANT GR DR	275904-004 101817	10/24/2017	10/27/2017	260.33	
492	CENTRAL VA ELECTRIC COOP	ELECTRICAL SERVICES	E911 TOWER	275904-009 101817	10/24/2017	10/27/2017	329.56	
493	CENTRAL VA ELECTRIC COOP	STREET LIGHTS	THOMAS JEFF PKWY	85473-001 101817	10/24/2017	10/27/2017	67.34	
494	CENTURYLINK 589-8525	TELECOMMUNICATIONS	PAYPHONE	A391626	10/4/2017	10/6/2017	50.00	
495	CENTURYLINK	TELECOMMUNICATIONS	FINANCE	309762613 091617	10/4/2017	10/6/2017	155.80	
496	CENTURYLINK	TELECOMMUNICATIONS	FINANCE	309762613 091617	10/4/2017	10/6/2017	667.06	
497	CENTURYLINK	TELECOMMUNICATIONS	MONTHLY CHARGES	309363296 101617	10/24/2017	10/27/2017	527.33	
498	CII SERVICE	MAINTENANCE CONTRACTS	CONTRACT	42115	10/18/2017	10/20/2017	3,229.00	
499	CINTAS	MAINTENANCE CONTRACTS	FIRST AID	5008543219	10/18/2017	10/20/2017	197.84	
500	CINTAS	MAINTENANCE CONTRACTS	FIRST AID	9016771769	10/18/2017	10/20/2017	370.10	
501	CINTAS	MAINTENANCE CONTRACTS	FIRST AID	5009069550	10/24/2017	10/27/2017	318.41	
502	DOMINION VIRGINIA POWER	ELECTRICAL SERVICES	BUS GARAGE	9974215007 092717	10/4/2017	10/6/2017	6.88	
503	DOMINION VIRGINIA POWER	ELECTRICAL SERVICES	JAIL MUSEUM	1424085007 092517	10/4/2017	10/6/2017	9.91	
504	DOMINION VIRGINIA POWER	ELECTRICAL SERVICES	51 COURT SQ	1114097502 092717	10/4/2017	10/6/2017	11.40	
505	DOMINION VIRGINIA POWER	ELECTRICAL SERVICES	222 MAIN ST	1134080009 092717	10/4/2017	10/6/2017	11.50	
506	DOMINION VIRGINIA POWER	ELECTRICAL SERVICES	196 MAIN ST	1124090000 092717	10/4/2017	10/6/2017	26.25	
507	DOMINION VIRGINIA POWER	ELECTRICAL SERVICES	PERFORMING ARTS	4144237502 092217	10/4/2017	10/6/2017	26.25	
508	DOMINION VIRGINIA POWER	ELECTRICAL SERVICES	CELL TOWER	5699060132 092717	10/4/2017	10/6/2017	33.09	
509	DOMINION VIRGINIA POWER	ELECTRICAL SERVICES	8952 JAMES MAD HWY	3023889169 092217	10/4/2017	10/6/2017	50.99	
510	DOMINION VIRGINIA POWER	ELECTRICAL SERVICES	LG BALL FIELD	0692200942 092717	10/4/2017	10/6/2017	61.56	



	A	B	C	D	F	G	H	J
1	County of Fluvanna		From Date: 10/1/2017					
2	Accounts Payable List		To Date: 10/31/2017					
3								
4								
6	Vendor Name	Charge To	Description	Invoice Number	Invoice Date	Check Date	Check Amount	
511	DOMINION VIRGINIA POWER	ELECTRICAL SERVICES	SM BALL FIELD	0274195007 092717	10/4/2017	10/6/2017	90.14	
512	DOMINION VIRGINIA POWER	ELECTRICAL SERVICES	211 MAIN ST	1284152509 092717	10/4/2017	10/6/2017	104.98	
513	DOMINION VIRGINIA POWER	ELECTRICAL SERVICES	PUMP HOUSE	4501632147 092517	10/4/2017	10/6/2017	130.87	
514	DOMINION VIRGINIA POWER	ELECTRICAL SERVICES	197 MAIN ST	1304130006 092717	10/4/2017	10/6/2017	142.12	
515	DOMINION VIRGINIA POWER	ELECTRICAL SERVICES	CELL TOWER	6260822157 092817	10/4/2017	10/6/2017	142.86	
516	DOMINION VIRGINIA POWER	ELECTRICAL SERVICES	181 MAIN ST	6274752663 092717	10/4/2017	10/6/2017	181.22	
517	DOMINION VIRGINIA POWER	ELECTRICAL SERVICES	35 COURT SQ	1144090006 092217	10/4/2017	10/6/2017	190.97	
518	DOMINION VIRGINIA POWER	ELECTRICAL SERVICES	GYMNASIUM	0084297506 092217	10/4/2017	10/6/2017	230.99	
519	DOMINION VIRGINIA POWER	ELECTRICAL SERVICES	90 RESCUE LN	4894115007 092217	10/4/2017	10/6/2017	235.80	
520	DOMINION VIRGINIA POWER	ELECTRICAL SERVICES	15704 W RIVER RD	8866300000 092817	10/4/2017	10/6/2017	256.16	
521	DOMINION VIRGINIA POWER	ELECTRICAL SERVICES	14567 JAMES MAD HWY	1005898992 092217	10/4/2017	10/6/2017	361.87	
522	DOMINION VIRGINIA POWER	ELECTRICAL SERVICES	5725 JAMES MAD HWY	4331888158 092517	10/4/2017	10/6/2017	370.71	
523	DOMINION VIRGINIA POWER	ELECTRICAL SERVICES	TREAS OFFICE	1024205005 092217	10/4/2017	10/6/2017	397.10	
524	DOMINION VIRGINIA POWER	ELECTRICAL SERVICES	5753 JAMES MAD HWY	4834680458 092517	10/4/2017	10/6/2017	463.00	
525	DOMINION VIRGINIA POWER	ELECTRICAL SERVICES	8880 JAMES MAD HWY	2554330007 092717	10/4/2017	10/6/2017	470.63	
526	DOMINION VIRGINIA POWER	ELECTRICAL SERVICES	72 MAIN ST	1404067504 092217	10/4/2017	10/6/2017	593.44	
527	DOMINION VIRGINIA POWER	ELECTRICAL SERVICES	SOCIAL SERVICES	0074032509 092217	10/4/2017	10/6/2017	1,177.81	
528	DOMINION VIRGINIA POWER	ELECTRICAL SERVICES	132 MAIN ST	8895892548 092217	10/4/2017	10/6/2017	2,007.15	
529	DOMINION VIRGINIA POWER	STREET LIGHTS	BESIDE POST OFFICE	7080078962 092817	10/4/2017	10/6/2017	77.07	
530	DOMINION VIRGINIA POWER	STREET LIGHTS	NEAR MASONIC LODGE	9609027314 092817	10/4/2017	10/6/2017	82.44	
531	DOMINION VIRGINIA POWER	STREET LIGHTS	COLUMBIA ST LIGHTS	4210122349 092717	10/4/2017	10/6/2017	202.72	
532	DOMINION VIRGINIA POWER	STREET LIGHTS	PALMYRA VILLAGE	3595578927 092717	10/4/2017	10/6/2017	474.38	
533	INTRASTATE PEST	MAINTENANCE CONTRACTS	CHARGES	949219	10/18/2017	10/20/2017	38.00	
534	INTRASTATE PEST	MAINTENANCE CONTRACTS	SERVICES	949221	10/18/2017	10/20/2017	38.00	
535	INTRASTATE PEST	MAINTENANCE CONTRACTS	SERVICES	947906	10/18/2017	10/20/2017	45.00	
536	INTRASTATE PEST	MAINTENANCE CONTRACTS	MONTHLY SERVICE	953218	10/24/2017	10/27/2017	28.00	
537	INTRASTATE PEST	MAINTENANCE CONTRACTS	MONTHLY SERVICE	953235	10/24/2017	10/27/2017	32.00	
538	INTRASTATE PEST	MAINTENANCE CONTRACTS	MONTHLY SERVICE	953213	10/24/2017	10/27/2017	58.00	
539	INTRASTATE PEST	MAINTENANCE CONTRACTS	MONTHLY SERVICE	953221	10/24/2017	10/27/2017	109.00	
540	REPUBLIC SERVICES #410	MAINTENANCE CONTRACTS	WASTE CONTAINERS	0410-000639497	10/11/2017	10/13/2017	1,734.42	
541	THE SUPPLY ROOM	WATER SERVICES	COOLER RENTAL	3100029-0	10/11/2017	10/13/2017	9.99	
542	THE SUPPLY ROOM	WATER SERVICES	COOLER RENTAL	3100035-0	10/11/2017	10/13/2017	9.99	
543	THE SUPPLY ROOM	WATER SERVICES	COOLER RENTAL	3100036-0	10/11/2017	10/13/2017	19.98	
544	THE SUPPLY ROOM	WATER SERVICES	5 GALLON	3091933-0	10/18/2017	10/20/2017	19.96	
545	TREASURER, FLUVANNA CO	SEWER SERVICES	211 MAIN ST	33612	10/18/2017	10/20/2017	12.30	
546	TREASURER, FLUVANNA CO	SEWER SERVICES	197 MAIN ST	33610	10/18/2017	10/20/2017	13.83	
547	TREASURER, FLUVANNA CO	SEWER SERVICES	181 MAIN ST	33609	10/18/2017	10/20/2017	15.36	
548	TREASURER, FLUVANNA CO	SEWER SERVICES	160 COMMONS BLVD	33620	10/18/2017	10/20/2017	25.30	
549	TREASURER, FLUVANNA CO	SEWER SERVICES	214 COMMONS BLVD	33621	10/18/2017	10/20/2017	25.30	
550	TREASURER, FLUVANNA CO	SEWER SERVICES	1730 THOMAS JEFF PKWY	33631	10/18/2017	10/20/2017	25.30	
551	TREASURER, FLUVANNA CO	SEWER SERVICES	132 MAIN ST	33603	10/18/2017	10/20/2017	27.60	
552	TREASURER, FLUVANNA CO	SEWER SERVICES	72 MAIN ST	33602	10/18/2017	10/20/2017	32.19	



	A	B	C	D	F	G	H	J	
1	County of Fluvanna		From Date: 10/1/2017						
2	Accounts Payable List		To Date: 10/31/2017						
3									
4									
6	Vendor Name	Charge To	Description	Invoice Number	Invoice Date	Check Date	Check Amount		
553	TREASURER, FLUVANNA CO	WATER SERVICES	5725 JAMES MAD HWY	33928	10/18/2017	10/20/2017	21.00		
554	TREASURER, FLUVANNA CO	WATER SERVICES	8880 JAMES MAD HWY	33983	10/18/2017	10/20/2017	21.00		
555	TREASURER, FLUVANNA CO	WATER SERVICES	8878 JAMES MAD HWY	33984	10/18/2017	10/20/2017	21.00		
556	TREASURER, FLUVANNA CO	WATER SERVICES	5753 JAMES MAD HWY	33985	10/18/2017	10/20/2017	22.10		
557	TREASURER, FLUVANNA CO	WATER SERVICES	8878 JAMES MAD HWY	33799	10/18/2017	10/20/2017	28.70		
558	TREASURER, FLUVANNA CO	WATER SERVICES	8880 JAMES MAD HWY	33800	10/18/2017	10/20/2017	59.50		
559	W & H RESOURCES, INC	MAINTENANCE CONTRACTS	MAINTENANCE	12149	10/11/2017	10/13/2017	1,725.00		
560								Total:	\$27,942.11
561									
562	PUBLIC WORKS								
563	CENTURYLINK	TELECOMMUNICATIONS	FINANCE	309762613 091617	10/4/2017	10/6/2017	10.13		
564	MANSFIELD OIL COMPANY OF GAINESVILLE,	VEHICLE FUEL	FUEL	SQLCD/356406	10/4/2017	10/6/2017	28.19		
565	STAPLES CONTRACT & COMMERCIAL, INC.	OFFICE SUPPLIES	SUPPLIES	8046663058	10/18/2017	10/20/2017	(\$309.99)		
566	STAPLES CONTRACT & COMMERCIAL, INC.	OFFICE SUPPLIES	SUPPLIES	8046663058	10/18/2017	10/20/2017	6.72		
567	STAPLES CONTRACT & COMMERCIAL, INC.	OFFICE SUPPLIES	SUPPLIES	8046663058	10/18/2017	10/20/2017	9.42		
568	STAPLES CONTRACT & COMMERCIAL, INC.	OFFICE SUPPLIES	SUPPLIES	8046663058	10/18/2017	10/20/2017	39.04		
569	STAPLES CONTRACT & COMMERCIAL, INC.	OFFICE SUPPLIES	SUPPLIES	8046663058	10/18/2017	10/20/2017	65.31		
570	STAPLES CONTRACT & COMMERCIAL, INC.	OFFICE SUPPLIES	SUPPLIES	8046663058	10/18/2017	10/20/2017	125.00		
571	STAPLES CONTRACT & COMMERCIAL, INC.	OFFICE SUPPLIES	SUPPLIES	8046663058	10/18/2017	10/20/2017	309.95		
572	VERIZON	TELECOMMUNICATIONS	WIRELESS	9794804823	10/24/2017	10/27/2017	100.16		
573	VIRGINIA BUSINESS SYSTEMS	LEASE/RENT	PRINTER	21383730	10/4/2017	10/6/2017	93.04		
574	VIRGINIA BUSINESS SYSTEMS	LEASE/RENT	COPIER	21400764	10/11/2017	10/13/2017	254.19		
575								Total:	\$731.16
576									
577	CONVENIENCE CENTER								
578	BFI - FLUVANNA TRANSFER STATION	CONTRACT SERVICES	TRASH	4347-000006056	10/11/2017	10/13/2017	2,216.06		
579	BFI - FLUVANNA TRANSFER STATION	CONTRACT SERVICES	TRASH	4347-000006060	10/24/2017	10/27/2017	2,268.18		
580	CAMPBELL EQUIPMENT, INC.	CONTRACT SERVICES	DISPOSAL	101817A	10/24/2017	10/27/2017	148.00		
581	CAROLINA SOFTWARE	BLDGS EQUIP REP & MAINT	SOFTWARE SUPPORT	65869	10/11/2017	10/13/2017	250.00		
582	CENTURYLINK	TELECOMMUNICATIONS	LANDFILL SCALES	310392717 101617	10/24/2017	10/27/2017	67.23		
583	JAMES RIVER SOLUTIONS	VEHICLE FUEL	FUEL	100217	10/11/2017	10/13/2017	153.52		
584	MO-JOHNS, INC.	LEASE/RENT	PORTABLE TOILET	103611	10/4/2017	10/6/2017	60.00		
585	RUHLMAN'S HAULING	BLDGS EQUIP REP & MAINT	SERVICES	092117	10/24/2017	10/27/2017	1,262.40		
586	VERIZON	TELECOMMUNICATIONS	WIRELESS	9794804823	10/24/2017	10/27/2017	90.28		
587								Total:	\$6,515.67
588									
589	HEALTH								
590	THOMAS JEFFERSON HEALTH DISTRICT	CONTRACT SERVICES	FY18 2ND QTR ALLOCATION	100117	10/4/2017	10/6/2017	67,447.50		
591								Total:	\$67,447.50
592									
593	CSA								
594	CENTURYLINK	TELECOMMUNICATIONS	FINANCE	309762613 091617	10/4/2017	10/6/2017	3.38		



	A	B	C	D	F	G	H	J	
1	County of Fluvanna		From Date: 10/1/2017						
2	Accounts Payable List		To Date: 10/31/2017						
3									
4									
6	Vendor Name	Charge To	Description	Invoice Number	Invoice Date	Check Date	Check Amount		
595	STAPLES CONTRACT & COMMERCIAL, INC.	OFFICE SUPPLIES	SUPPLIES	8046663058	10/18/2017	10/20/2017	39.42		
596	STAPLES CONTRACT & COMMERCIAL, INC.	OFFICE SUPPLIES	SUPPLIES	8046663058	10/18/2017	10/20/2017	41.74		
597	STAPLES CONTRACT & COMMERCIAL, INC.	OFFICE SUPPLIES	SUPPLIES	8046663058	10/18/2017	10/20/2017	57.48		
598	STAPLES CONTRACT & COMMERCIAL, INC.	OFFICE SUPPLIES	SUPPLIES	8046663058	10/18/2017	10/20/2017	80.08		
599							Total:	\$222.10	
600									
601	CSA PURCHASE OF SERVICES								
602	A. JAMES ANDERSON, P.H.D	COMM SVCS		P09919507177	9/30/2017	10/27/2017	1,350.00		
603		COMM SVCS		P09919508849	9/30/2017	10/20/2017	360.00		
604	BELIEVE IN ME YOUTH & FAMILY SERVICES,	COMM SVCS		P09919500976	9/30/2017	10/6/2017	675.00		
605	BELIEVE IN ME YOUTH & FAMILY SERVICES,	COMM SVCS		P09000900378	9/30/2017	10/6/2017	900.00		
606	BELIEVE IN ME YOUTH & FAMILY SERVICES,	COMM SVCS		P09000823377	9/30/2017	10/6/2017	1,125.00		
607	BELIEVE IN ME YOUTH & FAMILY SERVICES,	COMM SVCS		P09000901375	9/30/2017	10/6/2017	1,250.00		
608	BELIEVE IN ME YOUTH & FAMILY SERVICES,	COMM SVCS		P08919500906	8/31/2017	10/13/2017	1,125.00		
609	DETOUR MENTORING	COMM SVCS		P09919526282	9/30/2017	10/6/2017	330.00		
610	DETOUR MENTORING	COMM SVCS		P09919511588	9/30/2017	10/6/2017	440.00		
611	DETOUR MENTORING	COMM SVCS		P09919511384	9/30/2017	10/6/2017	715.00		
612	DETOUR MENTORING	COMM SVCS		P09000828180	9/30/2017	10/6/2017	1,210.00		
613	DETOUR MENTORING	COMM SVCS		P09919511183	9/30/2017	10/6/2017	1,265.00		
614	DETOUR MENTORING	COMM SVCS		P09919511281	9/30/2017	10/6/2017	1,265.00		
615	DETOUR MENTORING	COMM SVCS		P09000822779	9/30/2017	10/6/2017	1,320.00		
616	DETOUR MENTORING	COMM SVCS		P09919511687	9/30/2017	10/6/2017	1,320.00		
617	DETOUR MENTORING	COMM SVCS		P09919511785	9/30/2017	10/6/2017	2,200.00		
618	DETOUR MENTORING	COMM SVCS		P09919511886	9/30/2017	10/6/2017	2,200.00		
619		POS MANDATED FFOP		P09919507595	9/30/2017	10/6/2017	1,820.00		
620		POS MANDATED FFOP		P09919506296	9/30/2017	10/6/2017	2,268.00		
621	DISCOVERY SCHOOL	RES. CONG. CARE		P09000824502	9/30/2017	10/6/2017	4,992.00		
622	DISCOVERY SCHOOL	RES. CONG. CARE		P09000829001	9/30/2017	10/6/2017	6,060.00		
623	DISCOVERY SCHOOL	RES. CONG. CARE		P09919506399	9/30/2017	10/6/2017	6,060.00		
624	ELK HILL	COMM SVCS		P09919506046	9/30/2017	10/20/2017	563.75		
625	ELK HILL	COMM SVCS		P09919507645	9/30/2017	10/20/2017	701.25		
626	EXTRA SPECIAL PARENTS, INC.	POS MANDATED WSS		P08000824705	8/31/2017	10/6/2017	750.00		
627	EXTRA SPECIAL PARENTS, INC.	POS MANDATED WSS		P09000824787	9/30/2017	10/27/2017	675.00		
628	FAMILY PRESERVATION SERV.	COMM SVCS		P08000827164	8/31/2017	10/6/2017	1,187.50		
629	FAMILY PRESERVATION SERV.	COMM SVCS		P08919511408	8/31/2017	10/13/2017	495.00		
630	FAMILY PRESERVATION SERV.	COMM SVCS		P08919512907	8/31/2017	10/13/2017	630.00		
631	FAMILY PRESERVATION SERV.	COMM SVCS		P07000900013	7/31/2017	10/13/2017	720.00		
632	FAMILY PRESERVATION SERV.	COMM SVCS		P08919511909	8/31/2017	10/13/2017	825.00		
633	FAMILY PRESERVATION SERV.	COMM SVCS		P08919513410	8/31/2017	10/13/2017	1,237.50		
634	FAMILY PRESERVATION SERV.	COMM SVCS		P08919513111	8/31/2017	10/13/2017	1,410.00		
635	FAMILY PRESERVATION SERV.	COMM SVCS		P08919523339	8/31/2017	10/20/2017	175.00		
636	FAMILY PRESERVATION SERV.	COMM SVCS		P09919523348	9/30/2017	10/20/2017	525.00		



	A	B	C	D	F	G	H	J
1	County of Fluvanna		From Date: 10/1/2017					
2	Accounts Payable List		To Date: 10/31/2017					
3								
4								
6	Vendor Name	Charge To	Description	Invoice Number	Invoice Date	Check Date	Check Amount	
637	FAMILY PRESERVATION SERV.	COMM SVCS		P08000827241	8/31/2017	10/20/2017	1,185.00	
638	FAMILY PRESERVATION SERV.	COMM SVCS		P08919523238	8/31/2017	10/20/2017	1,245.00	
639	FAMILY PRESERVATION SERV.	COMM SVCS		P09919523247	9/30/2017	10/20/2017	1,411.00	
640	FAMILY PRESERVATION SERV.	COMM SVCS		P08000827340	8/31/2017	10/20/2017	1,487.50	
641	FAMILY PRESERVATION SERV.	COMM SVCS		P09000900879	9/25/2017	10/27/2017	660.00	
642	FAMILY PRESERVATION SERV.	COMM SVCS		P09000827178	9/30/2017	10/27/2017	962.50	
643	FAMILY PRESERVATION SERV.	COMM SVCS		P07000900874	7/31/2017	10/27/2017	1,050.00	
644	FAMILY PRESERVATION SERV.	COMM SVCS		P08000900873	8/31/2017	10/27/2017	1,155.00	
645	FAMILY PRESERVATION SERV.	COMM SVCS		P09000827380	9/30/2017	10/27/2017	1,387.50	
646	FAMILY PRESERVATION SERV.	COMM SVCS		P09000827281	9/30/2017	10/27/2017	1,615.00	
647	FLUVANNA DEPARTMENT OF SOCIAL	COMM SVCS		P09919530589	9/1/2017	10/6/2017	1,473.00	
648	FLUVANNA DEPARTMENT OF SOCIAL	COMM SVCS		P09919531190	9/24/2017	10/6/2017	1,473.00	
649	FLUVANNA DEPARTMENT OF SOCIAL	COMM SVCS		P10919528974	10/1/2017	10/6/2017	1,473.00	
650	FLUVANNA DEPARTMENT OF SOCIAL	COMM SVCS		P10919536476	10/12/2017	10/27/2017	473.00	
651	FLUVANNA DEPARTMENT OF SOCIAL	COMM SVCS		P10919536575	10/12/2017	10/27/2017	473.00	
652	FLUVANNA DEPARTMENT OF SOCIAL	COMM SVCS		P09919537182	9/27/2017	10/27/2017	1,394.00	
653	FLUVANNA DEPARTMENT OF SOCIAL	COMM SVCS		P09919537283	9/27/2017	10/27/2017	1,394.00	
654		COMM SVCS		P09919503044	9/30/2017	10/20/2017	802.00	
655	GPM INVESTMENTS LLC	COMM SVCS		P08000900765	8/31/2017	10/6/2017	100.00	
656	GRAFTON INTERGRATED HEALTH	EDUC SVCS CONG CARE		P07000829292	7/31/2017	10/6/2017	4,160.00	
657	GRAFTON INTERGRATED HEALTH	RES. CONG. CARE		P07000829197	7/31/2017	10/6/2017	285.00	
658	GRAFTON INTERGRATED HEALTH	RES. CONG. CARE		P07000829300	7/31/2017	10/6/2017	1,750.00	
659	GRAFTON INTERGRATED HEALTH	RES. CONG. CARE		P07000829498	7/31/2017	10/6/2017	2,015.00	
660	HALLMARK YOUTHCARE	EDUC SVCS CONG CARE		P09919526160	9/29/2017	10/20/2017	117.00	
661	HALLMARK YOUTHCARE	EDUC SVCS CONG CARE		P08919526157	8/31/2017	10/20/2017	468.00	
662	HALLMARK YOUTHCARE	EDUC SVCS CONG CARE		P08919529656	8/31/2017	10/20/2017	580.00	
663	HALLMARK YOUTHCARE	EDUC SVCS CONG CARE		P09919532059	9/30/2017	10/20/2017	580.00	
664	HALLMARK YOUTHCARE	EDUC SVCS CONG CARE		P09919529658	9/25/2017	10/20/2017	2,175.00	
665	HALLMARK YOUTHCARE	POS MAND PSYC		P09919530766	9/25/2017	10/23/2017	2,427.50	
666	HALLMARK YOUTHCARE	POS MAND PSYC		P09919531965	9/30/2017	10/23/2017	2,427.50	
667	HALLMARK YOUTHCARE	POS MAND PSYC		P08919530162	8/31/2017	10/23/2017	3,884.00	
668	HALLMARK YOUTHCARE	POS MAND PSYC		P08919530763	8/31/2017	10/23/2017	3,884.00	
669	HALLMARK YOUTHCARE	POS MAND PSYC		P09919530164	9/25/2017	10/23/2017	12,137.50	
670	INTERCEPT YOUTH SERVICE	COMM SVCS		P07919512314	7/31/2017	10/13/2017	644.00	
671	INTERCEPT YOUTH SERVICE	POS MAND FC LIC RES CONG		P09919506821	9/30/2017	10/13/2017	8,662.50	
672	INTERCEPT YOUTH SERVICE	POS MAND FC LIC RES CONG		P07919506820	7/31/2017	10/13/2017	8,951.25	
673	INTERCEPT YOUTH SERVICE	POS MAND FC LIC RES CONG		P08919506819	8/31/2017	10/13/2017	8,951.25	
674		POS MANDATED FFOP		P09919530486	9/30/2017	10/27/2017	700.00	
675		COMM SVCS		P07000822873	7/31/2017	10/6/2017	600.00	
676		COMM SVCS		P09000822955	9/30/2017	10/20/2017	300.00	
677		POS MANDATED FFOP		P09919517193	9/30/2017	10/6/2017	700.00	
678		POS MANDATED FFOP		P09919526694	9/30/2017	10/6/2017	1,344.00	



	A	B	C	D	F	G	H	J
1	County of Fluvanna		From Date: 10/1/2017					
2	Accounts Payable List		To Date: 10/31/2017					
3								
4								
6	Vendor Name	Charge To	Description	Invoice Number	Invoice Date	Check Date	Check Amount	
679	LAFAYETTE SCHOOL, INC.	POS MANDATED SPED-		P09000825829	9/30/2017	10/20/2017	5,800.00	
680	LAFAYETTE SCHOOL, INC.	POS MANDATED SPED-		P09000825932	9/30/2017	10/20/2017	5,800.00	
681	LAFAYETTE SCHOOL, INC.	POS MANDATED SPED-		P09000826030	9/30/2017	10/20/2017	5,800.00	
682	LAFAYETTE SCHOOL, INC.	POS MANDATED SPED-		P09000826131	9/30/2017	10/20/2017	5,800.00	
683	LAFAYETTE SCHOOL, INC.	POS MANDATED SPED-		P09000826228	9/30/2017	10/20/2017	5,800.00	
684	LIONHEART RESORT LLC	EDUC SVCS CONG CARE		P08000825791	8/31/2017	10/6/2017	9,150.00	
685	LIONHEART RESORT LLC	EDUC SVCS CONG CARE		P09000825785	9/30/2017	10/27/2017	8,970.00	
686		POS MANDATED FFOP		P09919507461	9/30/2017	10/20/2017	776.00	
687		POS MANDATED FFOP		P08919529922	8/31/2017	10/13/2017	1,516.39	
688		POS MANDATED FFOP		P09919530624	9/30/2017	10/13/2017	2,044.00	
689	NATIONAL COUNSELING GROUP	COMM SVCS		P08000824866	8/31/2017	10/6/2017	304.98	
690	NATIONAL COUNSELING GROUP	COMM SVCS		P07000901671	7/31/2017	10/6/2017	848.64	
691	NATIONAL COUNSELING GROUP	COMM SVCS		P08000901667	8/31/2017	10/6/2017	848.64	
692	NATIONAL COUNSELING GROUP	COMM SVCS		P09919506951	9/30/2017	10/20/2017	224.00	
693	NATIONAL COUNSELING GROUP	COMM SVCS		P08919505442	8/31/2017	10/20/2017	780.00	
694	NATIONAL COUNSELING GROUP	COMM SVCS		P09919505450	9/30/2017	10/20/2017	780.00	
695	NATIONAL COUNSELING GROUP	COMM SVCS		P07000901943	7/31/2017	10/20/2017	1,074.06	
696	NATIONAL COUNSELING GROUP	COMM SVCS		P09919509052	9/30/2017	10/20/2017	1,225.26	
697	NATIONAL COUNSELING GROUP	COMM SVCS		P09000824884	9/30/2017	10/27/2017	384.54	
698	NATIONAL COUNSELING GROUP	POS MANDATED WSS		P09000900588	9/30/2017	10/27/2017	265.20	
699	NORTH SPRING BEHAVIORAL HEALTHCARE,	EDUC SVCS CONG CARE		P08000901818	8/31/2017	10/13/2017	3,024.58	
700	PEOPLE PLACES, INC.	COMM SVCS		P09000901517	9/30/2017	10/13/2017	826.88	
701	PEOPLE PLACES, INC.	COMM SVCS		P09919522916	9/30/2017	10/13/2017	1,187.50	
702	PEOPLE PLACES, INC.	TFC LIC. RES CONG CARE		P07919523704	7/31/2017	10/6/2017	2,480.00	
703	PEOPLE PLACES, INC.	TFC LIC. RES CONG CARE		P08919523703	8/31/2017	10/6/2017	2,480.00	
704	PEOPLE PLACES, INC.	TFC LIC. RES CONG CARE		P09919523826	9/30/2017	10/13/2017	950.00	
705	PEOPLE PLACES, INC.	TFC LIC. RES CONG CARE		P07919523068	7/31/2017	10/20/2017	555.00	
706	PEOPLE PLACES, INC.	TFC LIC. RES CONG CARE		P09919523069	9/30/2017	10/20/2017	2,664.00	
707	PEOPLE PLACES, INC.	TFC LIC. RES CONG CARE		P08919523067	8/31/2017	10/20/2017	3,441.00	
708	REGION TEN	COMM SVCS		P08000829568	8/31/2017	10/6/2017	1,643.85	
709	REGION TEN	POS MANDATED WSS		P10000902627	10/6/2017	10/13/2017	553.06	
710	SECURE CHILD IN- HOME PROGRAM	COMM SVCS		P08919524369	8/31/2017	10/6/2017	280.00	
711	SECURE CHILD IN- HOME PROGRAM	COMM SVCS		P07000900972	7/31/2017	10/6/2017	1,365.00	
712	SECURE CHILD IN- HOME PROGRAM	COMM SVCS		P08000900970	8/31/2017	10/6/2017	3,010.00	
713	SECURE CHILD IN- HOME PROGRAM	COMM SVCS		P09919524353	9/30/2017	10/20/2017	1,680.00	
714	SECURE CHILD IN- HOME PROGRAM	COMM SVCS		P09000900954	9/30/2017	10/20/2017	2,800.00	
715		COMM SVCS		P07919512715	7/31/2017	10/13/2017	660.00	
716		COMM SVCS		P08919512712	8/31/2017	10/13/2017	690.00	
717	THE FAISON SCHOOL FOR AUTISM, INC.	POS MANDATED SPED-		P07000826563	7/31/2017	10/6/2017	315.00	
718	THE FAISON SCHOOL FOR AUTISM, INC.	POS MANDATED SPED-		P08000826555	8/31/2017	10/6/2017	367.50	
719	THE FAISON SCHOOL FOR AUTISM, INC.	POS MANDATED SPED-		P07000826361	7/31/2017	10/6/2017	4,080.00	
720	THE FAISON SCHOOL FOR AUTISM, INC.	POS MANDATED SPED-		P08000826353	8/31/2017	10/6/2017	4,845.00	



	A	B	C	D	F	G	H	J
1	County of Fluvanna		From Date: 10/1/2017					
2	Accounts Payable List		To Date: 10/31/2017					
3								
4								
6	Vendor Name	Charge To	Description	Invoice Number	Invoice Date	Check Date	Check Amount	
721	THE FAISON SCHOOL FOR AUTISM, INC.	POS MANDATED SPED-		P07000826462	7/31/2017	10/6/2017	4,880.00	
722	THE FAISON SCHOOL FOR AUTISM, INC.	POS MANDATED SPED-		P08000826454	8/31/2017	10/6/2017	5,795.00	
723	THE FAISON SCHOOL FOR AUTISM, INC.	POS MANDATED SPED-		P09000826570	9/30/2017	10/27/2017	420.00	
724	THE FAISON SCHOOL FOR AUTISM, INC.	POS MANDATED SPED-		P09000826372	9/30/2017	10/27/2017	4,845.00	
725	THE FAISON SCHOOL FOR AUTISM, INC.	POS MANDATED SPED-		P09000826471	9/30/2017	10/27/2017	5,795.00	
726		POS MANDATED FFOP		P08919534223	8/31/2017	10/13/2017	1,820.00	
727		POS MANDATED FFOP		P09919531025	9/24/2017	10/13/2017	1,820.00	
728	VIRGINIA INSTITUTE OF AUTISM	POS MANDATED SPED-		P08000825558	8/31/2017	10/6/2017	675.00	
729	VIRGINIA INSTITUTE OF AUTISM	POS MANDATED SPED-		P08000825459	8/31/2017	10/6/2017	6,400.00	
730	VIRGINIA INSTITUTE OF AUTISM	POS MANDATED SPED-		P08000825056	8/31/2017	10/6/2017	6,775.00	
731	VIRGINIA INSTITUTE OF AUTISM	POS MANDATED SPED-		P08000825257	8/31/2017	10/6/2017	7,075.00	
732	VIRGINIA INSTITUTE OF AUTISM	POS MANDATED SPED-		P08000825360	8/31/2017	10/6/2017	7,412.50	
733	VIRGINIA INSTITUTE OF AUTISM	POS MANDATED SPED-		P09000825535	9/30/2017	10/20/2017	750.00	
734	VIRGINIA INSTITUTE OF AUTISM	POS MANDATED SPED-		P09000825434	9/30/2017	10/20/2017	8,000.00	
735	VIRGINIA INSTITUTE OF AUTISM	POS MANDATED SPED-		P09000825033	9/30/2017	10/20/2017	8,300.00	
736	VIRGINIA INSTITUTE OF AUTISM	POS MANDATED SPED-		P09000825236	9/30/2017	10/20/2017	8,900.00	
737	VIRGINIA INSTITUTE OF AUTISM	POS MANDATED SPED-		P09000825337	9/30/2017	10/20/2017	9,050.00	
738						Total:	\$325,904.58	
739								
740	PARKS & RECREATION							
741	ALBEMARLE LOCK & SAFE, INC.	SITE IMPROVEMENTS	MASTER	69713	10/18/2017	10/20/2017	346.75	
742	ASHLEIGH MORRIS	PROFESSIONAL SERVICES	DOG CLASS	6 10/3/17	10/11/2017	10/13/2017	660.00	
743	ATWOOD REPROGRAPHICS, INC	SITE IMPROVEMENTS	MAP PRINTED	152456	10/18/2017	10/20/2017	493.05	
744	AUTOMATED OFFICE SYSTEMS	LEASE/RENT	COLOR PRINTER	078349	10/11/2017	10/13/2017	29.63	
745	AUTOMATED OFFICE SYSTEMS	LEASE/RENT	COLOR PRINTER	078348	10/11/2017	10/13/2017	129.00	
746	BANK OF AMERICA	CONVENTION AND	P-CARD PURCHASES	093017	10/17/2017	10/20/2017	(150.00)	
747	BANK OF AMERICA	RECREATIONAL SUPPLIES	P-CARD PURCHASES	093017	10/17/2017	10/20/2017	11.32	
748	BANK OF AMERICA	RECREATIONAL SUPPLIES	P-CARD PURCHASES	093017	10/17/2017	10/20/2017	19.95	
749	BANK OF AMERICA	RECREATIONAL SUPPLIES	P-CARD PURCHASES	093017	10/17/2017	10/20/2017	20.40	
750	BANK OF AMERICA	RECREATIONAL SUPPLIES	P-CARD PURCHASES	093017	10/17/2017	10/20/2017	20.45	
751	BANK OF AMERICA	RECREATIONAL SUPPLIES	P-CARD PURCHASES	093017	10/17/2017	10/20/2017	27.64	
752	BANK OF AMERICA	RECREATIONAL SUPPLIES	P-CARD PURCHASES	093017	10/17/2017	10/20/2017	34.69	
753	BANK OF AMERICA	RECREATIONAL SUPPLIES	P-CARD PURCHASES	093017	10/17/2017	10/20/2017	34.97	
754	BANK OF AMERICA	RECREATIONAL SUPPLIES	P-CARD PURCHASES	093017	10/17/2017	10/20/2017	40.22	
755	BANK OF AMERICA	RECREATIONAL SUPPLIES	P-CARD PURCHASES	093017	10/17/2017	10/20/2017	40.91	
756	BANK OF AMERICA	RECREATIONAL SUPPLIES	P-CARD PURCHASES	093017	10/17/2017	10/20/2017	249.46	
757	BANK OF AMERICA	RECREATIONAL SUPPLIES	P-CARD PURCHASES	093017	10/17/2017	10/20/2017	345.60	
758	BANK OF AMERICA	SITE IMPROVEMENTS	P-CARD PURCHASES	093017	10/17/2017	10/20/2017	35.79	
759	BANK OF AMERICA	SITE IMPROVEMENTS	P-CARD PURCHASES	093017	10/17/2017	10/20/2017	199.43	
760	BETTER LIVING, INC.	SITE IMPROVEMENTS	SUPPLIES	BMZ00718376	10/11/2017	10/13/2017	696.68	
761	BONNIE SNODDY	PROFESSIONAL SERVICES	KARATE	7 101117	10/11/2017	10/13/2017	423.50	
762	CENTURYLINK	TELECOMMUNICATIONS	PARKS N REC	309373828 101617	10/24/2017	10/27/2017	411.00	

	A	B	C	D	F	G	H	J	
1	County of Fluvanna		From Date: 10/1/2017						
2	Accounts Payable List		To Date: 10/31/2017						
3									
4									
6	Vendor Name	Charge To	Description	Invoice Number	Invoice Date	Check Date	Check Amount		
763	CHALLENGER SPORTS CORPORATION	PROFESSIONAL SERVICES	CAMP FEES	0008677-IN	10/11/2017	10/13/2017	176.00		
764	DEVI PETERSON	PROFESSIONAL SERVICES	YOGA	8	10/11/2017	10/13/2017	427.20		
765	DOODYCALLS FRANCHISING, LLC.	RECREATIONAL SUPPLIES	SUPPLIES	100000335	10/24/2017	10/27/2017	153.16		
766	E.W. THOMAS	GENERAL MATERIALS AND	SUPPLIES	100617	10/11/2017	10/13/2017	25.35		
767	E.W. THOMAS	RECREATIONAL SUPPLIES	SUPPLIES	100617	10/11/2017	10/13/2017	101.45		
768	FUN EXPRESS LLC	RECREATIONAL SUPPLIES	HALLOWEEN SUPPLIES	685609877-01	10/11/2017	10/13/2017	394.70		
769	JAMES RIVER SOLUTIONS	VEHICLE FUEL	FUEL	100217	10/11/2017	10/13/2017	186.08		
770	MO-JOHNS, INC.	CONTRACT SERVICES	PORTABLE TOILET	104133	10/18/2017	10/20/2017	60.00		
771	MO-JOHNS, INC.	CONTRACT SERVICES	PORTABLE TOILET	104134	10/18/2017	10/20/2017	60.00		
772	MO-JOHNS, INC.	CONTRACT SERVICES	PORTABLE TOILET	104137	10/18/2017	10/20/2017	60.00		
773	MO-JOHNS, INC.	CONTRACT SERVICES	HANDICAP UNIT	104136	10/18/2017	10/20/2017	100.00		
774	MO-JOHNS, INC.	CONTRACT SERVICES	PORTABLE TOILET	104135	10/18/2017	10/20/2017	120.00		
775	POSTMASTER	POSTAL SERVICES	PO BOX 70 ANNUAL FEE	101117	10/18/2017	10/20/2017	116.00		
776	SAM'S CLUB	RECREATIONAL SUPPLIES	ACCT 6045002021679179	101817	10/24/2017	10/27/2017	325.34		
777	STAPLES CONTRACT & COMMERCIAL, INC.	OFFICE SUPPLIES	SUPPLIES	8046663058	10/18/2017	10/20/2017	87.00		
778	STAPLES CONTRACT & COMMERCIAL, INC.	OFFICE SUPPLIES	SUPPLIES	8046663058	10/18/2017	10/20/2017	176.17		
779	THE SUPPLY ROOM	CONTRACT SERVICES	COOLER RENTAL	3100032-0	10/11/2017	10/13/2017	9.99		
780	THE SUPPLY ROOM	CONTRACT SERVICES	COOLER RENTAL	3100031-0	10/18/2017	10/20/2017	9.99		
781	THE SUPPLY ROOM	CONTRACT SERVICES	COOLER RENTAL	3100030-0	10/18/2017	10/20/2017	19.98		
782	VACORP	WORKER'S COMPENSATION	WORKERS COMP	14293	6/30/2017	10/26/2017	2,922.00		
783	VERIZON	TELECOMMUNICATIONS	WIRELESS	9794804823	10/24/2017	10/27/2017	200.32		
784	VIRGINIA BUSINESS SYSTEMS	LEASE/RENT	COPIER	21362214	10/11/2017	10/13/2017	33.34		
785	VIRGINIA BUSINESS SYSTEMS	LEASE/RENT	COPIER	21362211	10/11/2017	10/13/2017	120.31		
786	VIRGINIA RECREATION & PARK SOCIETY	RECREATIONAL SUPPLIES	TICKETS SOLD SEPT	37563	10/18/2017	10/20/2017	117.00		
787							Total:	\$10,121.82	
788									
789	LIBRARY								
790	ADVANTAGE OFFICE SYSTEMS	OFFICE SUPPLIES	SUPPLIES	6074	10/24/2017	10/27/2017	119.00		
791	EBSCO INFORMAITON SERVICES	BOOKS/PUBLICATIONS	SOFTWARE	1000064788-1	10/11/2017	10/13/2017	3,200.00		
792	GALE	BOOKS/PUBLICATIONS	BOOKS	61956716	10/11/2017	10/13/2017	52.70		
793	MICROMARKETING LLC	BOOKS/PUBLICATIONS	DVD	690148	10/11/2017	10/13/2017	14.99		
794	MICROMARKETING LLC	BOOKS/PUBLICATIONS	UNCD	689983	10/11/2017	10/13/2017	49.99		
795	MICROMARKETING LLC	BOOKS/PUBLICATIONS	DVDs	691319	10/24/2017	10/27/2017	60.03		
796	MICROMARKETING LLC	BOOKS/PUBLICATIONS	BOOKS	692200	10/24/2017	10/27/2017	105.92		
797	OVERDRIVE	BOOKS/PUBLICATIONS	BOOK	03100DA 17050205	10/11/2017	10/13/2017	2.99		
798	OVERDRIVE	BOOKS/PUBLICATIONS	BOOK	03100DA 17037699	10/11/2017	10/13/2017	3.99		
799	OVERDRIVE	BOOKS/PUBLICATIONS	BOOKS	03100DA 17047924	10/11/2017	10/13/2017	29.98		
800	OVERDRIVE	BOOKS/PUBLICATIONS	BOOKS	03100DA 17041885	10/11/2017	10/13/2017	113.83		
801	OVERDRIVE	BOOKS/PUBLICATIONS	BOOKS	03100CO17029146	10/11/2017	10/13/2017	208.34		
802	OVERDRIVE	BOOKS/PUBLICATIONS	BOOKS	03100CO17029160	10/11/2017	10/13/2017	276.57		
803	OVERDRIVE	BOOKS/PUBLICATIONS	BOOKS	03100CO17029194	10/11/2017	10/13/2017	932.55		
804	STAPLES CONTRACT & COMMERCIAL, INC.	OFFICE SUPPLIES	SUPPLIES	1911011891	10/24/2017	10/27/2017	126.88		



	A	B	C	D	F	G	H	J
1	County of Fluvanna		From Date: 10/1/2017					
2	Accounts Payable List		To Date: 10/31/2017					
3								
4								
6	Vendor Name	Charge To	Description	Invoice Number	Invoice Date	Check Date	Check Amount	
805	THE SUPPLY ROOM	LEASE/RENT	COOLER RENTAL	3100034-0	10/11/2017	10/13/2017	9.99	
806							Total:	\$5,307.75
807								
808	COUNTY PLANNER							
809	ATLANTIC TECHNOLOGY CONSULTANTS INC	CONTRACT SERVICES	APP REVIEW	1416	10/18/2017	10/20/2017	950.00	
810	ATLANTIC TECHNOLOGY CONSULTANTS INC	CONTRACT SERVICES	APP REVIEW	1417	10/18/2017	10/20/2017	950.00	
811	BANK OF AMERICA	DUES OR ASSOCIATION	P-CARD PURCHASES	093017	10/17/2017	10/20/2017	50.00	
812	CENTURYLINK	TELECOMMUNICATIONS	FINANCE	309762613 091617	10/4/2017	10/6/2017	20.25	
813	JAMES RIVER SOLUTIONS	VEHICLE FUEL	FUEL	100217	10/11/2017	10/13/2017	181.70	
814	MANSFIELD OIL COMPANY OF GAINESVILLE,	VEHICLE FUEL	FUEL	SQLCD/356406	10/4/2017	10/6/2017	23.77	
815	TIMMONS GROUP	CONTRACT SERVICES	PARCEL MAINTENANCE	194018	10/18/2017	10/20/2017	600.00	
816	TIMMONS GROUP	CONTRACT SERVICES	PARCEL MAINTENANCE	197790	10/18/2017	10/20/2017	600.00	
817	VERIZON	TELECOMMUNICATIONS	WIRELESS	9794804823	10/24/2017	10/27/2017	150.24	
818	VIRGINIA BUSINESS SYSTEMS	LEASE/RENT	COPIER	21383729	10/4/2017	10/6/2017	93.04	
819	VIRGINIA BUSINESS SYSTEMS	LEASE/RENT	COPIER	21362212	10/4/2017	10/6/2017	422.11	
820							Total:	\$4,041.11
821								
822	PLANNING COMMISSION							
823	FLUVANNA REVIEW	ADVERTISING	PAGE AD	2017F39-8	10/11/2017	10/13/2017	168.75	
824	FLUVANNA REVIEW	ADVERTISING	PAGE AD	2017F40-13	10/11/2017	10/13/2017	168.75	
825							Total:	\$337.50
826								
827	ECONOMIC DEVELOPMENT							
828	BANK OF AMERICA	CONVENTION AND	FY17 BANK OF AMERICA CHARGES	630171	6/30/2017	10/20/2017	650.00	
829	BANK OF AMERICA	OTHER OPERATING	P-CARD PURCHASES	093017	10/17/2017	10/20/2017	12.10	
830	BANK OF AMERICA	OTHER OPERATING	P-CARD PURCHASES	093017	10/17/2017	10/20/2017	18.25	
831	BANK OF AMERICA	OTHER OPERATING	P-CARD PURCHASES	093017	10/17/2017	10/20/2017	18.92	
832	BANK OF AMERICA	OTHER OPERATING	P-CARD PURCHASES	093017	10/17/2017	10/20/2017	18.95	
833	BANK OF AMERICA	OTHER OPERATING	P-CARD PURCHASES	093017	10/17/2017	10/20/2017	26.67	
834	BANK OF AMERICA	OTHER OPERATING	P-CARD PURCHASES	093017	10/17/2017	10/20/2017	32.76	
835	BANK OF AMERICA	OTHER OPERATING	P-CARD PURCHASES	093017	10/17/2017	10/20/2017	44.23	
836	BANK OF AMERICA	OTHER OPERATING	P-CARD PURCHASES	093017	10/17/2017	10/20/2017	48.56	
837	BANK OF AMERICA	OTHER OPERATING	P-CARD PURCHASES	093017	10/17/2017	10/20/2017	59.64	
838	BANK OF AMERICA	OTHER OPERATING	P-CARD PURCHASES	093017	10/17/2017	10/20/2017	70.60	
839	BANK OF AMERICA	OTHER OPERATING	P-CARD PURCHASES	093017	10/17/2017	10/20/2017	81.00	
840	BANK OF AMERICA	OTHER OPERATING	P-CARD PURCHASES	093017	10/17/2017	10/20/2017	128.00	
841	BANK OF AMERICA	OTHER OPERATING	P-CARD PURCHASES	093017	10/17/2017	10/20/2017	172.69	
842	BANK OF AMERICA	OTHER OPERATING	P-CARD PURCHASES	093017	10/17/2017	10/20/2017	355.75	
843	BANK OF AMERICA	OTHER OPERATING	P-CARD PURCHASES	093017	10/17/2017	10/20/2017	598.59	
844	BRANDY PRINTING & EMBROIDERY INC	OTHER OPERATING	SHIRTS	E 10548	10/4/2017	10/6/2017	160.66	
845	CENTURYLINK	TELECOMMUNICATIONS	FINANCE	309762613 091617	10/4/2017	10/6/2017	3.38	
846	ECONOMIC DEVELOPMENT OF	FLU ECO DEV AUTHORITY	ANNUAL ALLOCATION	102317	10/24/2017	10/27/2017	1,000.00	



	A	B	C	D	F	G	H	J	
1	County of Fluvanna		From Date: 10/1/2017						
2	Accounts Payable List		To Date: 10/31/2017						
3									
4									
6	Vendor Name	Charge To	Description	Invoice Number	Invoice Date	Check Date	Check Amount		
847	JASON SMITH	MILEAGE ALLOWANCES	MILEAGE	092517	10/4/2017	10/6/2017	118.77		
848	JASON SMITH	MILEAGE ALLOWANCES	MILEAGE	101117	10/24/2017	10/27/2017	118.77		
849	RYAN PACE COMMUNICATIONS	MARKETING	NEW COVER DESIGN	FLU_005	10/4/2017	10/6/2017	675.00		
850	STAPLES CONTRACT & COMMERCIAL, INC.	OFFICE SUPPLIES	SUPPLIES	8046663058	10/18/2017	10/20/2017	44.06		
851	STAPLES CONTRACT & COMMERCIAL, INC.	OFFICE SUPPLIES	SUPPLIES	8046663058	10/18/2017	10/20/2017	119.98		
852	VERIZON	TELECOMMUNICATIONS	WIRELESS	9794804823	10/24/2017	10/27/2017	50.08		
853								Total:	\$4,627.41
854									
855	VA COOPERATIVE EXTENSION								
856	BRITTNEY REDMAN	CONVENTION AND	REIMBURSEMENT	101817	10/24/2017	10/27/2017	27.50		
857	CENTURYLINK	TELECOMMUNICATIONS	FINANCE	309762613 091617	10/4/2017	10/6/2017	16.88		
858	VESA	DUES OR ASSOCIATION	DUES-KIM MAYO	102417	10/24/2017	10/27/2017	200.00		
859	VIRGINIA COOPERATIVE EXTENSION	CONTRACT SERVICES	FY 2018 1ST QTR	100417	10/18/2017	10/20/2017	9,301.69		
860								Total:	\$9,546.07
861									
862	NON PROFITS								
863	BANK OF AMERICA	YOUTH ADVISORY COUNCIL	P-CARD PURCHASES	093017	10/17/2017	10/20/2017	11.27		
864	BANK OF AMERICA	YOUTH ADVISORY COUNCIL	P-CARD PURCHASES	093017	10/17/2017	10/20/2017	24.06		
865	E.W. THOMAS	YOUTH ADVISORY COUNCIL	SUPPLIES	100617	10/11/2017	10/13/2017	40.60		
866	JAUNT, INC.	JAUNT	FY18 2ND QTR ALLOCATION	100117	10/4/2017	10/6/2017	19,851.00		
867	JEFFERSON AREA BOARD FOR AGING	JEFFERSON AREA	FY18 2ND QTR ALLOCATION	100117	10/4/2017	10/6/2017	20,986.50		
868	JEFFERSON AREA CHIP	JEFFERSON AREA CHIP	FY18 2ND QTR ALLOCATION	100117	10/4/2017	10/6/2017	12,750.00		
869	MONTICELLO AREA COMMUNITY ACTION	MACAA	FY18 2ND QTR ALLOCATION	100117	10/4/2017	10/6/2017	12,478.25		
870	PIEDMONT VIRGINIA COMMUNITY COLLEGE	PIEDMONT VA. COMM.	FY18 2ND QTR ALLOCATION	100117	10/4/2017	10/6/2017	12,607.25		
871	REGION TEN	REGION TEN COMMUNITY	FY18 2ND QTR ALLOCATION	100117	10/4/2017	10/6/2017	31,562.50		
872	THOMAS JEFFERSON PLANNING DISTRICT	T J PLANNING DIST. COMM.	FY18 2ND QTR ALLOCATION	100117	10/4/2017	10/6/2017	8,482.00		
873								Total:	\$118,793.43
874									
875								100 GENERAL FUND	Fund Total: \$1,006,087.39
876	Fund # - 302 CAPITAL IMPROVEMENT								
877	PUBLIC SAFETY CAPITAL PROJ								
878	CAPITAL AUTO GROUP	VEHICLE	INSTALL POLICE EQUIPMENT	H669366-INSTALL	10/24/2017	10/27/2017	2,432.25		
879	CAPITAL AUTO GROUP	VEHICLE	2017 DODGE CHARGER	H669366	10/24/2017	10/27/2017	24,968.50		
880	CLEAR COMMUNICATIONS AND	VEHICLE	CAR EQUIPMENT	113848	10/18/2017	10/20/2017	2,649.27		
881	MCLOUGHLIN & EARDLEY GROUP INC	VEHICLE	SUPPLIES	0220277-IN	10/4/2017	10/6/2017	241.20		
882								Total:	\$30,291.22
883									
884	FACILITIES CAP PROJ								
885	LOWE'S	CONTRACT SERVICES	SUPPLIES	092517	10/4/2017	10/6/2017	379.84		
886	MJC DESIGNS, LLC.	CONTRACT SERVICES		2597	10/24/2017	10/27/2017	134.00		
887	TRANE U.S., INC.	CONTRACT SERVICES	WORK COMPLETED SEP17	38469696	10/24/2017	10/27/2017	567,116.53		
888	VIRGINIA ASPHALT SERVICES INC	CONTRACT SERVICES	RESCUE SQUAD PAVING	4521	10/18/2017	10/20/2017	15,205.00		



	A	B	C	D	F	G	H	J	
1	County of Fluvanna		From Date: 10/1/2017						
2	Accounts Payable List		To Date: 10/31/2017						
3									
4									
6	Vendor Name	Charge To	Description	Invoice Number	Invoice Date	Check Date	Check Amount		
889							Total:	\$582,835.37	
890									
891	PUBLIC WORKS CAPITAL PROJECT								
892	BASIC RENT-A-CAR COMPANY, INC.	VEHICLE	PUBLIC WORKS VEHICLE	1114219	10/4/2017	10/6/2017		20,900.00	
893	BOWMAN CONSULTING	CONTRACT SERVICES	ZION CROSSROAD W&S	240324	10/11/2017	10/13/2017		1,147.50	
894	DEWBERRY ENGINEERS INC.	CONTRACT SERVICES	FLUCO W&S ENVIRON	1462885	10/11/2017	10/13/2017		4,500.00	
895							Total:	\$26,547.50	
896									
897	SCHOOL OPS & MAINT CAP PROJ								
898	DECKER EQUIPMENT	CONTRACT SERVICES	CIP SAFETY & SECURITY	212168A	10/4/2017	10/6/2017		1,581.71	
899	DODSON GLASS & MIRROR INC	CONTRACT SERVICES	SBO RENOVATION	JP 058826	10/4/2017	10/6/2017		12,493.45	
900	DRAPER ADEN ASSOCIATES	PROFESSIONAL SERVICES	MIDDLE SCHOOL REPAIRS	2017080312	10/4/2017	10/6/2017		3,117.65	
901							Total:	\$17,192.81	
902									
903	SCHOOL TECH CAP PROJ								
904	COMPUTER CABLING & TECHNOLOGY	CONTRACT SERVICES	FIBER PROJECT	092917	10/4/2017	10/6/2017		104,176.82	
905							Total:	\$104,176.82	
906									
907									
908	Fund # - 502 SEWER						302 CAPITAL IMPROVEMENT	Fund Total:	\$761,043.72
909	UTILITY OPERATIONAL EXPENSES								
910	ARTHURS SEPTIC SERVICE	CONTRACT SERVICES	MAINTENANCE	101717	10/24/2017	10/27/2017		185.00	
911	CENTURYLINK	TELECOMMUNICATIONS	WASTEWATER	910089744 091917	10/4/2017	10/6/2017		46.43	
912	CENTURYLINK	TELECOMMUNICATIONS	WASTEWATER	309433290 091917	10/4/2017	10/6/2017		58.93	
913	CINTAS	LAUNDRY AND DRY	DRY CLEANING	394147032	10/4/2017	10/6/2017		8.14	
914	CINTAS	LAUNDRY AND DRY	DRY CLEANING	394149067	10/11/2017	10/13/2017		8.14	
915	CINTAS	LAUNDRY AND DRY	DRY CLEANING	394151023	10/18/2017	10/20/2017		8.14	
916	CINTAS	LAUNDRY AND DRY	DRY CLEANING	394153005	10/24/2017	10/27/2017		8.14	
917	DOMINION VIRGINIA POWER	ELECTRICAL SERVICES	SW PUMP STATION	7712348080 092717	10/4/2017	10/6/2017		43.29	
918	DOMINION VIRGINIA POWER	ELECTRICAL SERVICES	SEWER PLANT	7129524547 092217	10/4/2017	10/6/2017		924.97	
919	E.W. THOMAS	CHEMICAL SUPPLIES	SUPPLIES	080117	10/11/2017	10/13/2017		2.58	
920	INBODEN ENVIRONMENTAL SERVICES, INC.	CONTRACT SERVICES	WASTEWATER MONITORING	63248	10/11/2017	10/13/2017		447.00	
921	INBODEN ENVIRONMENTAL SERVICES, INC.	CONTRACT SERVICES	WASTEWATER MONITORING	63249	10/11/2017	10/13/2017		447.00	
922	INBODEN ENVIRONMENTAL SERVICES, INC.	CONTRACT SERVICES	WASTEWATER MONITORING	63250	10/11/2017	10/13/2017		477.00	
923	JAMES RIVER SOLUTIONS	VEHICLE FUEL	FUEL	100217	10/11/2017	10/13/2017		88.06	
924	JONES AUTOMOTIVE/ALL STAR AUTO PARTS	BLDGS EQUIP REP & MAINT	SUPPLIES	471441	10/18/2017	10/20/2017		64.33	
925	LOWE'S	GENERAL MATERIALS AND	SUPPLIES	092517	10/4/2017	10/6/2017		617.20	
926	RIVANNA WATER & SEWER	CONTRACT SERVICES	WASTE DISPOSAL	INV10898	10/11/2017	10/13/2017		895.55	
927	USABLUEBOOK	GENERAL MATERIALS AND	SUPPLIES	371107	10/4/2017	10/6/2017		172.37	
928	USABLUEBOOK	GENERAL MATERIALS AND	SUPPLIES	385396	10/24/2017	10/27/2017		60.95	
929	VERIZON	TELECOMMUNICATIONS	WIRELESS	9794804823	10/24/2017	10/27/2017		131.08	
930	VSI SUPPLY	BLDGS EQUIP REP & MAINT	EQUIPMENT	S1221	10/11/2017	10/13/2017		47.25	

	A	B	C	D	F	G	H	J	
1	County of Fluvanna		From Date: 10/1/2017						
2	Accounts Payable List		To Date: 10/31/2017						
3									
4									
6	Vendor Name	Charge To	Description	Invoice Number	Invoice Date	Check Date	Check Amount		
931	VSI SUPPLY	BLDGS EQUIP REP & MAINT	EQUIPMENT	S1216	10/11/2017	10/13/2017	184.05		
932	VSI SUPPLY	BLDGS EQUIP REP & MAINT	EQUIPMENT	S1202	10/11/2017	10/13/2017	1,995.00		
933							Total:	\$6,920.60	
934									
935							502 SEWER	Fund Total:	\$6,920.60
936	Fund # - 505 FORK UNION SANITARY DISTRICT								
937	FUSD OPERATIONAL EXPENSES								
938	BANK OF AMERICA	PROFESSIONAL SERVICES	P-CARD PURCHASES	093017	10/17/2017	10/20/2017	121.50		
939	BANK OF AMERICA	VEHICLE/POWER EQUIP	P-CARD PURCHASES	093017	10/17/2017	10/20/2017	95.47		
940	CINTAS	LAUNDRY AND DRY	DRY CLEANING	394147032	10/4/2017	10/6/2017	38.13		
941	CINTAS	LAUNDRY AND DRY	DRY CLEANING	394149067	10/11/2017	10/13/2017	44.76		
942	CINTAS	LAUNDRY AND DRY	DRY CLEANING	394151023	10/18/2017	10/20/2017	31.48		
943	CINTAS	LAUNDRY AND DRY	DRY CLEANING	394153005	10/24/2017	10/27/2017	31.48		
944	DOMINION VIRGINIA POWER	ELECTRICAL SERVICES	MELTON WELL	9594215007 092517	10/4/2017	10/6/2017	17.31		
945	DOMINION VIRGINIA POWER	ELECTRICAL SERVICES	WEST BOTTOM WELL	7224360003 092517	10/4/2017	10/6/2017	69.78		
946	DOMINION VIRGINIA POWER	ELECTRICAL SERVICES	BREMO WELL	8434345008 092517	10/4/2017	10/6/2017	90.28		
947	DOMINION VIRGINIA POWER	ELECTRICAL SERVICES	OWENS WELL	9004200003 092517	10/4/2017	10/6/2017	190.45		
948	DOMINION VIRGINIA POWER	ELECTRICAL SERVICES	OMOHUNDRO WELL	9346182505 092517	10/4/2017	10/6/2017	673.49		
949	DOMINION VIRGINIA POWER	ELECTRICAL SERVICES	MORRIS WELL	9501772108 092517	10/4/2017	10/6/2017	715.18		
950	E.W. OWEN	LEASE/RENT	WELL RENT AUG	08012017	10/4/2017	10/6/2017	150.00		
951	E.W. OWEN	LEASE/RENT	WELL RENT SEP	09012017	10/4/2017	10/6/2017	150.00		
952	E.W. OWEN	LEASE/RENT	WELL RENT OCT	10012017	10/4/2017	10/6/2017	150.00		
953	JAMES RIVER SOLUTIONS	VEHICLE FUEL	FUEL	100217	10/11/2017	10/13/2017	190.29		
954	JONES AUTOMOTIVE/ALL STAR AUTO PARTS	CHEMICAL SUPPLIES	SUPPLIES	471441	10/18/2017	10/20/2017	103.20		
955	JONES AUTOMOTIVE/ALL STAR AUTO PARTS	VEHICLE/POWER EQUIP	SUPPLIES	471441	10/18/2017	10/20/2017	71.68		
956	MANSFIELD OIL COMPANY OF GAINESVILLE,	VEHICLE FUEL	FUEL	SQLCD/356406	10/4/2017	10/6/2017	350.65		
957	MANSFIELD OIL COMPANY OF GAINESVILLE,	VEHICLE FUEL	FUEL	SQLCD/361238	10/24/2017	10/27/2017	176.96		
958	MO-JOHNS, INC.	PURCHASE OF SERVICES	PORTABLE TOILET	103612	10/4/2017	10/6/2017	60.00		
959	SCHNEIDER LABRATORIES INC	PURCHASE OF SERVICES	LAB WORK ORDER	230373	10/11/2017	10/13/2017	30.00		
960	STAPLES CONTRACT & COMMERCIAL, INC.	OFFICE SUPPLIES	SUPPLIES	8046663058	10/18/2017	10/20/2017	11.63		
961	STAPLES CONTRACT & COMMERCIAL, INC.	OFFICE SUPPLIES	SUPPLIES	8046663058	10/18/2017	10/20/2017	39.04		
962	UNIVAR USA, INC.	CHEMICAL SUPPLIES	SUPPLIES	RI727939	10/24/2017	10/27/2017	1,561.77		
963	UNIVAR USA, INC.	CHEMICAL SUPPLIES	CHEMICAL SUPPLIES	RI727940	10/24/2017	10/27/2017	3,181.09		
964	USABLUBOOK	GENERAL MATERIALS AND	SUPPLIES	385441	10/24/2017	10/27/2017	913.41		
965	VERIZON	TELECOMMUNICATIONS	WIRELESS	9794804823	10/24/2017	10/27/2017	126.16		
966							Total:	\$9,385.19	
967									
968							505 FORK UNION SANITARY DISTRICT	Fund Total:	\$9,385.19
969							Total Expenditures by Fund:	\$1,783,436.90	



**FLUVANNA COUNTY BOARD OF SUPERVISORS
MEETING PACKAGE ATTACHMENTS**

November 15, 2017

No.	Item
1	Code Enforcement SUMMARY October 2017
2	FY17 Contingency Balance 2017-11-15
3	FY17 Capital Reserve Memo 2017-11-15
4	Unassigned Fund Balance 2017-11-15
5	Building Inspections Report October 2017
6	
7	
8	
9	
10	

CODE COMPLIANCE VIOLATION STATISTICS

October - 2017

Scott B. Miller, CZO, Code Inspector, Building Site Inspector

Complaint Number	Tax Map Number	Property Owner	Address	Date of Complaint	Violation Type	Status*	Deadline	District
1611-01	18-(A)-25B	Stevens, Roger	Thomas Farm La. (Vacant)	11/3/2016	Junk/Inoperable Vehicle	Court	4 Convictions - 10/24/2017	Palmyra
1705-02	36A-(A)-18	Cable, Louis A. & Susan V.	651 West River Rd.	5/9/2017	Signs	Extended	11/08/2017	Cunningham
1709-01	8-(A)-31	CP Burns Properties LLC.	677 Lake Monticello Rd.	9/17/2017	Improper Use - Junkyard	Pending	11/06/2017	Palmyra
1709-03	4-(A)-114	Herrion, Vernon L.	15 Blue Ridge Dr.	9/20/2017	Violation of SUP 04-10	Permit Pend	11/20/2017	Palmyra
1710-01	43-(A)-39	Partusch, Brian D.	4855 Stage Junction Rd.	10/17/2017	Improper Use - Junkyard	Extended	11/17/2017	Columbia
1710-02	40-(8)-6	Campbell, Heather M.	431 Haden Martin Rd.	10/18/2017	Trash	Cleared	n/a	Fork Union
1710-03	28-(A)-27	Bonilla, Jose A.	3337 Long Acre Rd.	10/20/2017	Setbacks	Cleared	n/a	Fork Union
1710-04	28-(A)-60	Landseadel, Jay B. & Cheryl B.	442 Middle Fork Rd.	10/24/2017	Noise Level – Shooting Exempt under State Code	Cleared	n/a	Cunningham
1710-05	36-(A)-61	Tate, Scottie et al	186 The Cross Rd.	10/25/2017	Burning - Tires	Cleared	n/a	Cunningham
1710-06	17-(20)-1	Allen, Robert C. & Lisa A.	71 Fox Hollow Ln.	10/27/2017	Cameras on Adj. Parcel	Cleared	n/a	Cunningham

STATUS DEFINITIONS*

Board - Case is pending Board Approval	Court Pending - Summons to be issued	Permit Pending - Applied for Permit to Abate Violation
Cleared - Violation Abated	Extended - Extension Given/Making Progress to Abate Violations	Rezoning - Property is in Rezoning Process
Court - Case is before Judge	Pending - Violation Notice Sent	SUP Pending - SUP Application made to Abate Violation

MISCELLANEOUS ACTIONS / TASKS

Biosolids Applied and Signs Displayed (Total – 54 Sites)

Compliance with Tenaska Virginia Sound Levels 10/17/2017

Signs Removed From Public Rights-Of-Way (Total – 32)

Placed and removed "Public Hearing Signs" as needed

Deliver packets to BOS, PC Members and Library

Evaluate County GIS and Circuit Court Records in regards to TM: 30A-(A)-33, portion of former property taken by VDOT for Route 15

COUNTY OF FLUVANNA

"Responsive & Responsible Government"

P.O. Box 540
 Palmyra, VA 22963
 (434) 591-1910
 Fax (434) 591-1911
www.fluvannacounty.org

MEMORANDUM

Date: November 15, 2017
From: Mary Anna Twisdale – Management Analyst
To: Board of Supervisors
Subject: FY18 BOS Contingency Balance

The FY18 BOS Contingency line balance is as follows:

Beginning Budget:	\$150,000
Less: Arts Council FY18 Allocation Grant Supplement – 06.07.17	-\$500
Less: Quitclaim and Release for FCSS Building – 08.16.17	-\$11,520
Less: Reimbursement of Legal Fees to Linda Lenherr – 09.20.17	-\$18,132
Less: Reimbursement to Fire for Transfer of Brush 10 to Public Works – 11.01.17	-\$20,000
Available:	\$99,848

COUNTY OF FLUVANNA

“Responsive & Responsible Government”

P.O. Box 540
Palmyra, VA 22963
(434) 591-1910
Fax (434) 591-1911
www.fluvannacounty.org

MEMORANDUM

Date: November 15, 2017
From: Mary Anna Twisdale – Management Analyst
To: Board of Supervisors
Subject: FY18 Capital Reserve Balances

The FY18 Capital Reserve account balances are as follows:

County Capital Reserve:

FY17 Carryover	\$134,975
FY18 Allocation:	\$175,000
Plus: Projects Completed July 2017	\$31
Less: Courts Building Well Repairs – 08.02.17	-\$7,800
Less: Bobcat Skid-Steer Major Repairs – 08.02.17	-\$2,400
Less: Additional Historic Courthouse Roof Repairs – 09.06.17	-\$10,000
Less: Courts Building Records Room HVAC – 09.06.17	-\$55,000
Less: Palmyra Rescue Asphalt and Concrete Slab – 09.20.17	-\$39,000
Less: Demolish Old Maintenance Shop and Dispose of Debris – 11.01.17	-\$40,000
Less: Design and Construction of Foundation Underpinning Along Front of Pleasant Grove House – 11.01.17	-\$27,500
Less: Secure Evidence Storage at Public Safety Building – 11.01.17	-\$8,550
Less: Replace Fencing and Expand Impound Lot at Public Safety Building – 11.01.17	-\$15,000
Available:	\$104,756

Schools Capital Reserve:

FY17 Carryover	\$238,603
FY18 Allocation:	\$75,000

Plus: Projects Completed July 2017	\$1,159
Less: Central HVAC Unexpected Repairs – 07.05.17	-\$6,226
Less: Bus Motor Repair – 10.04.17	-\$20,000
Less: Repair and Resurface FCHS Tennis Courts and Track – 10.04.17	-\$44,400
Less: Replace FCHS Baseball Bleachers – 10.04.17	-\$36,200
Less: Maintenance of Fire Extinguishers – 10.04.17	-\$7,980
Available:	\$199,956

COUNTY OF FLUVANNA

“Responsive & Responsible Government”

P.O. Box 540
 Palmyra, VA 22963
 (434) 591-1910
 Fax (434) 591-1911
 www.fluvannacounty.org

MEMORANDUM

Date: November 15, 2017
From: Mary Anna Twisdale – Management Analyst
To: Board of Supervisors
Subject: Unassigned Fund Balance

*FY17 Year End (Unaudited) Unassigned Fund Balance:	*\$4,840,117
Less: FY17 to FY18 Automatic Carryovers	-\$23,862
Less: ZXR Water. & Sewer Sys. Amend. to Agrmt. #3 (Dewberry) – 07.05.17	-\$4,500
Less: ZXR Water & Sewer Sys. Project Agreement #4 (Bowman) – 07.05.17	-\$6,880
Less: ZXR Water & Sewer Sys. Project Agreement #11 (Dewberry) – 07.05.17	-\$51,330
Less: ZXR Water & Sewer Sys. Project Agreement #5 (Bowman) – 07.05.17	-\$22,950
Less: ZXR Water & Sewer Sys. Amend. to Agrmt. #6 (Dewberry) – 09.06.17	-\$13,870
Less: ZXR Water & Sewer Sys. Project FY18 Interest Payments – 09.06.17	-\$224,852
Current (Unaudited) Unassigned Fund Balance:	*\$4,491,873

*Audited FY17 Year End Unassigned Fund Balance will be available upon completion of the FY17 CAFR

BUILDING INSPECTIONS MONTHLY REPORT

County of Fluvanna

Building Official:	Period:
Kevin Zoll	Oct-2017

Category	Year	Jan	Feb	Mar	Apr	May	Jun	Jul	Aug	Sep	Oct	Nov	Dec	TOTAL
BUILDING PERMITS ISSUED														
NEW - Single Family Detached	2015	4	5	10	9	12	12	14	13	2	4	7	3	95
	2016	11	11	8	15	9	18	6	5	9	2	6	8	108
	2017	3	2	16	6	4	10	6	5	14	5			71
NEW - Single Family Attached	2015	2	0	0	0	0	0	0	2	0	0	0	0	4
	2016	0	0	0	0	0	0	0	0	0	0	2	0	2
	2017	0	0	0	0	0	0	0	0	0	0	0	0	0
NEW - Mobil Homes	2015	0	0	0	0	1	1	0	2	0	0	0	0	4
	2016	0	1	0	0	0	0	0	1	0	0	0	0	2
	2017	0	0	0	0	2	1	0	1	0	0			4
Additions and Alterations	2015	21	30	38	28	21	30	22	25	23	27	35	18	318
	2016	13	10	31	27	29	29	15	32	31	28	27	27	299
	2017	29	20	29	43	20	29	32	18	23	27			270
Accessory Buildings	2015	4	4	3	4	1	0	0	2	6	0	0	3	27
	2016	3	4	4	6	2	2	1	2	1	3	3	6	37
	2017	0	4	2	3	2	2	2	4	2	0			21
Swimming Pools	2015	0	0	0	0	0	0	0	1	1	0	0	0	2
	2016	0	0	0	0	0	1	1	0	0	1	1	0	4
	2017	0	1	1	0	0	1	0	0	0	0		0	3
Commercial/Industrial Build/Cell Towers	2015	1	0	0	0	0	0	2	0	0	1	1	1	6
	2016	0	0	2	2	0	0	1	0	1	1	1	1	9
	2017	1	2	0	0	0	0	2	2	0	1			8
Land Disturbing Permits	2015	6	5	9	10	10	12	15	16	3	5	10	5	106
	2016	12	11	8	14	10	17	7	6	11	3	9	9	117
	2017	3	2	17	7	7	9	6	6	15	7			79
TOTAL PERMITS	2015	38	39	51	41	35	43	38	45	32	32	43	25	456
	2016	27	26	45	50	40	50	24	40	42	35	40	42	461
	2017	36	31	65	59	35	43	42	30	39	40	0	0	420
BUILDING VALUES FOR PERMITS ISSUED														
TOTAL BUILDING VALUES	2015	1,384,631	1,560,716	2,916,520	3,567,237	2,999,918	4,280,357	5,272,378	3,107,731	2,625,563	2,203,913	1,931,893	6,252,403	\$ 38,103,260
	2016	1,817,981	2,555,455	5,552,458	3,711,821	2,447,891	5,181,921	3,611,179	1,817,783	3,089,971	1,889,279	2,028,590	2,937,783	\$ 36,642,112
	2017	857,767	827,724	4,859,777	2,066,132	1,512,789	3,676,118	1,904,915	2,359,988	2,846,545	1,957,646			\$ 22,869,401
INSPECTIONS COMPLETED														
TOTAL INSPECTIONS	2015	105	137	146	214	113	232	193	181	208	206	149	149	2033
	2016	116	91	153	157	155	214	249	230	197	181	184	172	2099
	2017	159	144	171	141	177	152	202	182	153	183			1664
FEES COLLECTED														
Building Permits	2015	\$6,731	\$8,351	\$13,711	\$16,037	\$13,508	\$16,628	\$14,931	\$18,895	\$10,411	\$8,558	\$10,381	\$9,575	\$ 147,717
	2016	\$11,850	\$11,954	\$11,576	\$14,889	\$8,447	\$18,588	\$12,947	\$7,537	\$11,285	\$12,548	\$8,361	\$11,213	\$ 141,193
	2017	\$3,710	\$3,463	\$19,849	\$8,618	\$6,036	\$10,814	\$8,680	\$7,099	\$11,651	\$6,338			\$ 86,259
Land Disturbing Permits	2015	\$1,775	\$875	\$1,425	\$3,425	\$1,750	\$1,850	\$2,325	\$3,338	\$1,085	\$2,819	\$10,450	\$2,298	\$ 33,414
	2016	\$3,200	\$2,575	\$1,700	\$1,950	\$2,250	\$2,200	\$4,020	\$875	\$28,074	\$2,000	\$1,450	\$1,200	\$ 51,494
	2017	\$475	\$800	\$7,000	\$1,523	\$2,366	\$2,425	\$1,733	\$7,784	\$2,100	\$2,050	\$0	\$0	\$ 28,255
Zoning Permits/ Proffers	2015	\$1,200	\$1,000	\$1,650	\$2,600	\$1,500	\$1,850	\$1,850	\$2,400	\$1,650	\$1,050	\$950	\$1,700	\$ 18,500
	2016	\$1,150	\$1,250	\$1,800	\$2,450	\$1,650	\$2,700	\$1,150	\$1,150	\$1,900	\$1,050	\$900	\$850	\$ 18,950
	2017	\$400	\$1,000	\$2,400	\$950	\$1,500	\$1,800	\$1,245	\$1,250	\$1,600	\$1,000	\$0	\$0	\$ 13,145
TOTAL FEES	2015	\$ 9,706	\$ 10,226	\$ 16,786	\$ 22,062	\$ 16,758	\$ 20,328	\$ 19,106	\$ 24,632	\$ 13,146	\$ 12,427	\$ 21,731	\$ 12,722	\$ 199,631
	2016	\$ 16,200	\$ 15,779	\$ 15,076	\$ 19,289	\$ 12,347	\$ 23,488	\$ 18,117	\$ 9,562	\$ 41,259	\$ 15,348	\$ 11,411	\$ 13,763	\$ 211,637
	2017	\$ 4,585	\$ 5,263	\$ 29,249	\$ 11,091	\$ 9,902	\$ 15,039	\$ 11,658	\$ 16,130	\$ 9,338	\$ -	\$ -	\$ -	\$ 112,305