



FLUVANNA COUNTY BOARD OF SUPERVISORS

REGULAR MEETING AGENDA

Circuit Courtroom, Fluvanna Courts Building

November 20, 2018 at 7:00 pm

TAB AGENDA ITEMS

1 - CALL TO ORDER

2 - PLEDGE OF ALLEGIANCE AND MOMENT OF SILENCE

3 – ADOPTION OF AGENDA

4 – COUNTY ADMINISTRATOR’S REPORT

5 – PUBLIC COMMENTS #1 (5 minutes each)

6 – PUBLIC HEARING

- P Zion Crossroads Water/Sewer System Property Acquisition —Steven M. Nichols, County Administrator
- Q Piedmont Public Safety Communications System —Steven M. Nichols, County Administrator

7 – ACTION MATTERS

- R Approve and Accept Purchases and Deeds (Zion Crossroads Water and Sewer Project) – Fred Payne, County Attorney
- S FY18 4th Quarter Budget Report and FY18 to FY19 Carryover Requests—Eric Pollitt, Management Analyst
- T Department of Forestry Pole Shed Lease – Steve Nichols, County Administrator
- U Resolution Recommending Appointment to the Board of Equalization – Steve Nichols, County Administrator
- V Fluvanna County Building and Program Feasibility Study and Assessment—Cyndi Toler, Purchasing Officer

7A – APPOINTMENTS

None

8 – PRESENTATIONS (normally not to exceed 10 minutes each)

- W VPSA Series 2012 Escrow Earnings– Eric Dahl, DCA/Finance Director

9 – CONSENT AGENDA

- XYZ Minutes of October 17, 2018—Kelly Belanger Harris, Clerk to the Board
- A Minutes of November 7, 2018—Kelly Belanger Harris, Clerk to the Board
- B Revision to Policy 2.19 – Business and Travel Expenses – Steve Nichols, County Administrator
- C Accounts Payable, October 2018—Eric Dahl, Deputy County Administrator/Finance Director
- D FY19 Library State Aid Supplemental Appropriation—Eric Pollitt, Management Analyst
- E Open Space Contract – Hughes—Andrew M. Sheridan, Commissioner of the Revenue
- F Open Space Contract – McKee – Andrew M. Sheridan, Commissioner of the Revenue

Fluvanna County...The heart of Virginia and your gateway to the future!

- G Open Space Contract – Payne – Andrew M. Sheridan, Commissioner of the Revenue
- H Open Space Contract – Rittenhouse – Andrew M. Sheridan, Commissioner of the Revenue
- I Open Space Contract Renewal – Dawson– Andrew M. Sheridan, Commissioner of the Revenue
- J Open Space Contract Renewal – Dickey – Andrew M. Sheridan, Commissioner of the Revenue
- K Open Space Contract Renewal – Grubbs – Andrew M. Sheridan, Commissioner of the Revenue
- L Position Description Update – Assistant Public Works Director (3685) – Jessica Rice, HR Manager
- M Position Description – Engineering Project Manager (3685) – Jessica Rice, HR Manager

10 – UNFINISHED BUSINESS

TBD

11 – NEW BUSINESS

TBD

12 – PUBLIC COMMENTS #2 (5 minutes each)

13 – CLOSED MEETING

TBD

14 – ADJOURN

Steven M.
Nichols

Digitally signed by Steven
M. Nichols
Date: 2018.11.15 14:51:52
-05'00'

County Administrator Review

Fluvanna County...The heart of Virginia and your gateway to the future!

*For the Hearing-Impaired – Listening device available in the Board of Supervisors Room upon request. TTY access number is 711 to make arrangements.
For Persons with Disabilities – If you have special needs, please contact the County Administrator’s Office at 591-1910.*

PLEDGE OF ALLEGIANCE

I pledge allegiance, to the flag,
of the United States of America,
and to the Republic for which it stands,
one nation, under God, indivisible,
with liberty and justice for all.

ORDER

1. It shall be the duty of the Chairman to maintain order and decorum at meetings. The Chairman shall speak to points of order in preference to all other members.
2. In maintaining decorum and propriety of conduct, the Chairman shall not be challenged and no debate shall be allowed until after the Chairman declares that order has been restored. In the event the Board wishes to debate the matter of the disorder or the bringing of order; the regular business may be suspended by vote of the Board to discuss the matter.
3. No member or citizen shall be allowed to use defamatory or abusive language directed at any member of the Board or other person, to create excessive noise, or in any way incite persons to use such tactics. The Chair shall be the judge of such breaches, however, the Board may by majority vote of the Board members present and voting to overrule the judgment of the Chair.
4. When a person engages in such breaches, the Chairman shall order the person's removal from the building, or may order the person to stand silent, or may, if necessary, order the person removed from the County property.

PUBLIC HEARING RULES OF PROCEDURE

1. PURPOSE
 - The purpose of a public hearing is to receive testimony from the public on certain resolutions, ordinances or amendments prior to taking action.
 - A hearing is not a dialogue or debate. Its express purpose is to receive additional facts, comments and opinion on subject items.
2. SPEAKERS
 - Speakers should approach the lectern so they may be visible and audible to the Board.
 - Each speaker should clearly state his/her name and address.
 - All comments should be directed to the Board.
 - All questions should be directed to the Chairman. Members of the Board are not expected to respond to questions, and response to questions shall be made at the Chairman's discretion.
 - Speakers are encouraged to contact staff regarding unresolved concerns or to receive additional information.
 - Speakers with questions are encouraged to call County staff prior to the public hearing.
 - Speakers should be brief and avoid repetition of previously presented comments.
3. ACTION
 - At the conclusion of the public hearing on each item, the Chairman will close the public hearing.
 - The Board will proceed with its deliberation and will act on or formally postpone action on such item prior to proceeding to other agenda items.
 - Further public comment after the public hearing has been closed generally will not be permitted.

Fluvanna County...The heart of Virginia and your gateway to the future!



COUNTY OF FLUVANNA

"Responsive & Responsible Government"

P.O. Box 540
Palmyra, VA 22963
(434) 591-1910
Fax (434) 591-1911
www.fluvannacounty.org

2018-2019 STRATEGIC INITIATIVES AND ACTIONS

A SERVICE DELIVERY	
A1	Work with FRA to identify support options for Fire and Rescue volunteers.
A2	Continue to research and evaluate county-wide broadband expansion opportunities.
A3	Hold review meeting on ordinance enforcement (trash, buildings, vehicles) with Health Dept., Planning, Building Inspections, Public Works, and County Attorney.
A4	Perform strategic review of existing and needed partnerships with local area support and other non-profit groups. (Needed? Effective? Consolidate resource contributions?)
A5	Improve partnership with the school system for shared use of county and school owned facilities.
A6	Identify and assess resident concerns about roadway and public safety issues, and coordinate with VDOT for appropriate actions.
A7	Initiate comprehensive review of the Hwy 53 corridor from Lake Monticello Road to Ruritan Lake Road (e.g., Safety improvements at LM Monish Gate; 3-way stoplight at Food Lion; sight improvement at Ruritan Lake Road and Hwy 53; etc.)
B COMMUNICATION	
B1	Assess options to communicate more efficiently, effectively, and economically with Fluvanna residents.
B2	Marketing campaign to let residents know about accomplishments and where their tax dollars go.
B3	Meet with local Pastors to discuss effective communications and community support.
B4	Promote tax due dates, public hearings, etc., in FAN Mail.
B5	Expand County Website to receive, answer, and post questions from residents.
B6	Hold an Elected Official's Breakfast for our State Representatives in Fall of 2018
B7	Hold an Elected Official's Breakfast for our State Representatives in Fall of 2019
B8	Conduct 2019 Fluvanna County Residents Survey and analyze results.
C PROJECT MANAGEMENT	
C1	Continue Columbia area renewal efforts including improved enforcement of County/State codes and Health Department regulations.
C2	Complete a Master Water and Sewer (Plan Phase I) to identify sources for the county's long-term water needs; particularly for each of its community planning areas.
C3	Incorporate well-drilling logs provided by the Fluvanna Health Dept. into the county's geographic information system (GIS).
C4	Create master report and marketing plan regarding County tower assets and rental options.
C5	Investigate the use of Overlay Zones for the Zion Crossroads Community Planning Area to support economic development.

C6	Create a County-wide overlay map showing utilities and other key features that support business growth and development.
C7	Review and pursue opportunities and options for a Palmyra Village Streetscape project to improve safety, parking, walkability, and overall appearance.
C8	Successfully oversee and manage Fluvanna County aspects of the James River Water Project.
C9	Successfully oversee and manage the design and construction of the Zion Crossroads water and sewer system.
C10	Pursue Phase II of Fork Union streetscape project.
D	ECONOMIC DEVELOPMENT AND TOURISM
D1	Draft and adopt a formal County-wide economic development and tourism strategy inclusive of an implementation schedule.
D2	Develop a “This is Fluvanna County” video message to be shared with county citizens and businesses as well as use with county economic development initiatives.
D3	Coordinate development activity at Fluvanna’s northern border with Louisa County, including possible natural gas line along 250 and discussing “shared” parcels.
D4	Conduct 2018 local Business Climate Survey and analyze results.
D5	Hold an Economic Development Discussion Forum for local businesses with planning, zoning, building inspections, infrastructure components.
D6	Investigate and pursue with State offices the installation of select Boat Ramps along the Rivanna and James Rivers to support additional recreational and tourism opportunities.
D7	Investigate opportunities for park expansion or Rivanna River access points to support expanded recreational activities
D8	Investigate allowing large lot subdivisions in A-1 as alternative to current cluster subdivisions. (Amend the zoning and subdivision ordinances to allow for varying lot sizes, from small clustered lots to large parcels suitable for continued farming and rural living.)
D9	Review higher density options between PDA and R4.
D10	Review options, pros, cons, costs, etc., of creating a “teaching farm” at PG Park,
E	FINANCIAL STEWARDSHIP AND EFFICIENCY
E1	Review local business license/registration options and pros/cons.
E2	Reduce the County’s reliance on creating and mailing paper checks for payments and implement expanded ACH/EFT transaction options.
E3	Create monthly Treasurer’s Report for BOS Package and quarterly in-person briefing on the data.
E4	Implement credit card payment option for citizen at all County funds collection points through MUNIS Cashiering process.
E5	Expand Fluvanna County Website Data Dashboard with key metrics.
E6	Implement easy to access electronic format code of ordinances (MuniCode or similar).

**FLUVANNA COUNTY BOARD OF SUPERVISORS
AGENDA ITEM STAFF REPORT**

TAB P

MEETING DATE:	November 20, 2018				
AGENDA TITLE:	Public Hearing for ZXR WSS Condemnation				
MOTION(s):	I move the Board of Supervisors approve the attached resolution entitled, "RESOLUTION TO AUTHORIZE INITIATION OF CONDEMNATION PROCEEDINGS AND USE OF 'QUICK TAKE' PROCEDURES FOR ACQUISITION OF PROPERTY AND INTERESTS IN PROPERTY FOR THE ZION CROSSROADS WATER AND SEWER SYSTEM PROJECT."				
STRATEGIC INITIATIVE?	Yes	No	If yes, list initiative(s):	C9	
	X				
AGENDA CATEGORY:	Public Hearing	Action Matter	Presentation	Consent Agenda	Other
	XX				
STAFF CONTACT(S):	Steven M. Nichols, County Administrator, and Wayne Stephens, Engineering Project Manager				
PRESENTER(S):	Steven M. Nichols, County Administrator				
RECOMMENDATION:	Approve				
TIMING:	Current				
DISCUSSION:	<p>This public hearing and resolution are needed for the Zion Crossroads Water and Sewer Project in order to allow the County, where efforts to purchase are ineffectual, to acquire land and easements (the "interests") by condemnation. The resolution will additionally allow the County to use the "Quick Take" procedure authorized by statute in order to take the interests to be condemned and begin construction of the project prior to or during the condemnation proceedings (i.e., before the just compensation for the interests taken is determined by legal proceedings). This is necessary in order to allow construction of the project to be carried out expeditiously, in a coordinated manner, and to minimize expense and disruption due to delays in the acquisition of the necessary interests.</p> <p>Among other things, the resolution declares the necessity of the public water and sewer project, directs the acquisition of the interests, declares the necessity to enter and take the interests prior to or during the condemnation proceedings, confirms the approval of the project, confirms the approval of the offers of just compensation that have been sent to the owners, and authorizes the County Administrator and County Attorney to continue to carry out the process of acquisitions, including condemnation and filing certificates of take under the "Quick Take" procedure. The interests that are located on property owned by the Commonwealth of Virginia (Department of Corrections) and the interests that are outside Fluvanna County (in Louisa County) cannot be acquired by condemnation and are authorized by the resolution to be acquired by negotiation only.</p> <p>The County is legally obligated to make a bona fide effort to purchase before a certificate of take can be filed and condemnation proceedings instituted. A number</p>				

	of responses have been received to the County's initial offers – a few of the responses have rejected selling the interests needed, a larger number of responses have indicated a non-binding willingness to accept the compensation offered, and the largest number of owners have not responded. At this time, no conveyances to the County have been completed. Staff and the County Attorney's office have been and will continue to follow up with all owners, as appropriate and in compliance with applicable law, including to coordinate negotiated acquisitions to the extent possible.				
FISCAL IMPACT:	Offers have been sent to all of the owners listed on Exhibit A to the resolution that is before the Board. The offer amounts were provided by the Basic Administrative Reports (BARs) and Appraisals prepared by Bowman Consulting Group. To the extent that compensation cannot be negotiated with any owner who is subject to condemnation, the amount of just compensation will be determined in a judicial condemnation proceeding. By the use of the "Quick Take" procedure, it is anticipated that the just compensation amounts will be determined during or after the construction of the project				
POLICY IMPACT:	N/A				
LEGISLATIVE HISTORY:	After several years of planning and public input, on November 1, 2017, the Board of Supervisors approved the Zion Crossroads Water and Sewer Project, directed the development and issuance of invitations for bids for construction, and authorized commencing the process of coordinating acquisition of property interests, easements and rights of way for the project.				
ENCLOSURES:	<ul style="list-style-type: none"> Resolution with Exhibit A attached 				
REVIEWS COMPLETED:	Legal	Finance	Purchasing	HR	Other
	X	X			

Resolution to Authorize Initiation of Condemnation Proceedings and Use of “Quick Take” Procedures for Acquisition of Property and Interests in Property for the Zion Crossroads Water and Sewer System Project

WHEREAS, the Board of Supervisors of Fluvanna County, Virginia (the “Board”), on November 1, 2017, approved the plans, specifications, design elements, and estimated cost for the construction of a proposed water supply and sewage disposal system, including pipes and lines, in the Zion Crossroads area (the “Zion Crossroads Water and Sewer System Project”) and directed staff and the County Attorney to begin the process of coordinating the acquisition of all necessary property interests, easements, and rights of way, and develop and issue invitations for bids, for the construction thereof;

WHEREAS, in order to accomplish the Zion Crossroads Water and Sewer System Project it is necessary for Fluvanna County to acquire the property and interests in property (the “Property and Easements”) shown and described on the following surveys (the “Project Surveys”):

- (a) Survey entitled “Plat Showing Proposed Utility Easements & Temporary Construction Easements Palmyra Magisterial District Fluvanna County, Virginia and Green Springs Magisterial District Louisa County, Virginia”, made by Bowman Consulting Group, Ltd., dated October 1, 2018;
- (b) Survey entitled “Plat Showing Proposed Utility Easements & Temporary Construction Easements on the Property of Commonwealth of Virginia, Department of Corrections P.I.D. 4-A-97 D.B. 295 PG. 420 Palmyra Magisterial District Fluvanna County, Virginia”, made by Bowman Consulting Group, Ltd., dated August 16, 2018;
- (c) Survey entitled “Plat Showing Utility Lot 1 on the Property of Macon Properties LLC Deed Book 951 at Page 293 Palmyra District Fluvanna County, Virginia”, made by Bowman Consulting Group, Ltd., dated July 23, 2018;
- (d) Survey entitled “Plat Showing Utility Lot 2 & Easements on the Property of Margie Irene Glass and Rita Sue Glass, Trustees of the R.S. Glass Marital Trust PID: 5-A-52 & PID: 5-A-48 Palmyra District Fluvanna County, Virginia”, made by Bowman Consulting Group, Ltd., dated August 16, 2018;
- (e) Survey entitled “Plat Showing Utility Lot 2 on the Property of B Properties II LLC PID: 5-7-9 Deed Book 718 at Page 897 Palmyra District Fluvanna County, Virginia”, made by Bowman Consulting Group, Ltd., dated August 16, 2018;

WHEREAS, water supply and sewage disposal systems, including pipes and lines, when undertaken by a locality are inherently public uses as provided in Virginia Code § 15.2-1902 and, in accordance with Virginia Code §§ 15.2-1901 and 15.2-1901.1, Fluvanna County is authorized to acquire real property and interests in real property for public use by exercise of the power of eminent domain;

WHEREAS, in accordance with Virginia Code §§ 25.1-303, 25.1-204, and 25.1-417 title examinations of the Property and Easements have been conducted to identify the owners and the

nature and extent of their interests; the amount of just compensation to be offered for the Property and Easements has been established by appraisal, or by basic administrative report where appraisal is not required and less than the entire parcel is to be acquired; and the appraisals and basic administrative reports have been approved by the County Administrator, who is the Fluvanna County official responsible for the acquisition;

WHEREAS, in accordance with Virginia Code §§ 25.1-303, 25.1-204, and 25.1-417(A)(1), Fluvanna County has made a bona fide but as yet ineffectual effort to purchase, or consent cannot be obtained, from the owners of the Property and Easements listed on EXHIBIT A attached hereto and incorporated herein by reference (the “Outstanding Interests”);

WHEREAS, in order to move forward with the Zion Crossroads Water and Sewer System Project as expeditiously as possible, it is necessary for Fluvanna County to enter upon the Property and Easements as soon as practicable;

WHEREAS, on November 20, 2018, following proper notice published according to law, the Board has held a public hearing pursuant to Va. Code §§ 15.2-1903(B), 15.2-1904(A), and 15.2-1905(C);

NOW THEREFORE, BE IT HEREBY RESOLVED by the Board that:

- (1) All recitals set forth herein above are hereby incorporated as a part of this Resolution;
- (2) The Board declares that the Zion Crossroads Water and Sewer System Project will provide necessary public water and sewer service in the Zion Crossroads area and the construction, maintenance, and operation of the Zion Crossroads Water and Sewer System Project are public uses under Va. Code §§ 1-219.1 and 15.2-1902;
- (3) The Board hereby approves and re-approves the Zion Crossroads Water and Sewer System Project;
- (4) The Board hereby directs the acquisition of the Property and Easements for the Zion Crossroads Water and Sewer System Project by condemnation or other means, with the exception of the following, which the Board hereby directs to be acquired, if possible, by negotiation only, and not by condemnation: (i) any portion of the Property and Easements owned by the Commonwealth of Virginia, Department of Corrections; and (ii) any portion of the Property and Easements located in Louisa County, Virginia (being those portions of the Property and Easements owned by R.S. Glass Commercial Center, LC and Crescent Inn, LC);
- (5) The Board hereby declares and states that:
 - (i) it intends to enter and take the Outstanding Interests for the purposes of the Zion Crossroads Water and Sewer System Project;
 - (ii) the compensation and damages, if any, for the Outstanding Interests offered each property owner are set forth on EXHIBIT A attached hereto and incorporated herein by reference;

(iii) it is necessary to enter upon and take the Outstanding Interests prior to or during the condemnation proceedings for the purposes of the Zion Crossroads Water and Sewer System Project;

(6) The Board hereby ratifies and approves the written offers of just compensation for purchase of the Property and Easements by Fluvanna County previously delivered, or attempted to be delivered, to owner(s), including the factual basis for such offers and all exhibits thereto, and confirms that the acquisition of the Property and Easements complies with Virginia Code § 1-219.1;

(7) Steven M. Nichols, County Administrator of Fluvanna County, Virginia, and Frederick W. Payne, Fluvanna County Attorney, are hereby authorized and directed to take and authorize the taking of such actions, and to execute such documents, on behalf of Fluvanna County and/or the Board as may be necessary or appropriate to accomplish the acquisition of the Property and Easements and carry out the provisions of this resolution in accordance with applicable law, which may include but shall not be limited to instituting and conducting condemnation proceedings in the name of the Board in accordance with the “quick take” procedure set forth in Virginia Code § 25.1-300 et seq. and filing appropriate certificates of take in, and making appropriate payments into, the Circuit Court of Fluvanna County, Virginia.

Project Parcel No.	Owner	P.I.N./PID/Tax Map Parcel No.	Temporary Easement		Permanent Utility Easement		Permanent Drainage Easement		Ingress-Egress Easement		Land in Fee Simple		Total
			Size	Offer	Size	Offer	Size	Offer	Size	Offer	Size	Offer	Offer
71	Ellerson R. and Catherine E. Overton	5 13 5	0.057	\$100.00	0.1479	\$300.00							\$400.00
73	Xroads, LLC	5 10 2	0.2432	\$2,300.00	0.4841	\$8,900.00							\$11,200.00
74	Kloekner Metals Corp.	5 10 2A	0.3469	\$2,600.00	0.0252	\$400.00							\$3,000.00
75	Emanuel Brown, Ernesto V. Deomampo and Andy R. Clark, Trustees of the Covenant Church of God of Albemarle County, Virginia	5 17 1	0.2711	\$2,500.00	0.511	\$9,200.00							\$11,700.00
76	E. Randall Ralston and John S. Ralston, Trustees for the TCH Land Trust	5 A 45	0.1173	\$1,400.00	0.3414	\$7,800.00							\$9,200.00
77	Margie Irene Glass and Rita Sue Glass, Trustees of the R.S. Glass Marital Trust	5 7 10	0.1386	\$400.00	0.2427	\$1,200.00							\$1,600.00
78	B Properties II LLC	5 7 9	0.48652	\$10,703.00	1.08733	\$35,882.00	0.0824	\$5,438.00			0.45689	\$50,258.00	\$102,281.00
81	Margie Irene Glass and Rita Sue Glass, Trustees	5 A 52 & 5 A 48	0.32277	\$6,778.00	0.11304	\$3,561.00			0.11804	\$8,147.00	0.0854	\$8,967.00	\$27,453.00
82	Shenandoah Building Supply, Inc., now known as Commonwealth Building Materials, Inc.	5 16 4	0.056	\$1,200.00	0.1896	\$7,600.00							\$8,800.00
83	Margie Irene Glass, Trustee, or her Successors in Trust, under the Margie Irene Glass Trust Agreement	5 A 53	0.1844	\$300.00	0.4659	\$1,400.00							\$1,700.00
84	James H. Watson	5 A 54	0.0503	\$1,100.00	0.0264	\$1,100.00							\$2,200.00
85	Macon Properties LLC	5 A 55X	0.48193	\$5,783.00	0.46593	\$41,934.00					0.23563	\$28,276.00	\$75,993.00
86	PT Holdings, LLC	5 A 55A	0.0572	\$1,200.00	0.0887	\$3,600.00							\$4,800.00
87	James L. Higginbotham, Sr.	5 16 4A	0.0528	\$100.00	0.0247	\$100.00	0.0272	\$100.00					\$300.00

**FLUVANNA COUNTY BOARD OF SUPERVISORS
AGENDA ITEM STAFF REPORT**

TAB Q

MEETING DATE:	November 20, 2018				
AGENDA TITLE:	Public Hearing for Joint Intergovernmental Agreement with Louisa County and Required Ordinance				
MOTION(s):	I move the Board of Supervisors approve an ordinance entitled, "AN ORDINANCE APPROVING THE JOINT INTERGOVERNMENTAL AGREEMENT WITH LOUISA COUNTY FOR THE PIEDMONT PUBLIC SAFETY COMMUNICATIONS SYSTEM," and further authorize the County Administrator to execute the Intergovernmental Agreement and the Consent to Sublease subject to approval as to form by the County Attorney.				
STRATEGIC INITIATIVE?	Yes	No	If yes, list initiative(s):		
		X			
AGENDA CATEGORY:	Public Hearing	Action Matter	Presentation	Consent Agenda	Other
	XX				
STAFF CONTACT(S):	Debbie Smith, Emergency Management Coordinator, Michael Grandstaff, Director of Communications, and Steve Nichols, County Administrator				
PRESENTER(S):	Steven M. Nichols, County Administrator				
RECOMMENDATION:	Approve				
TIMING:	Current				
DISCUSSION:	<p>Pursuant to Section 15.2-1300 of the Code of Virginia, 1950, as amended, Fluvanna County and Louisa County desire to enter into an Intergovernmental Agreement to establish a Shared Public Safety Radio System referred to as the "Piedmont Public Safety Communications System." Enabling legislation requires localities to approve such agreements by ordinance and the County's financing of their system and equipment requires the execution of a Consent to Sublease.</p> <p>Louisa County's Board of Supervisors approved the Intergovernmental Agreement by a vote of 7-0 on October 15, 2018.</p>				
FISCAL IMPACT:	<p>As shown in Attachment 8 of the Intergovernmental Agreement</p> <p>Louisa will pay to Fluvanna one-half of the initial acquisition and installation cost of the System Core, with such amount determined to be \$380,689.03 as Louisa's required contribution to become a Party in the Piedmont System.</p> <p>The Parties shall be jointly and equally responsible for the costs associated with software upgrades.</p> <p>In addition, maintenance or other costs not covered by an existing contract will be agreed to in advance by each Party and each Party shall be responsible for fifty-percent of the costs thereof (currently estimated at ~\$78,000 per year for each party).</p>				

POLICY IMPACT:	Allows for sharing of costs between Fluvanna and Louisa, thereby reducing the full cost to each county to operate their respective emergency communication systems.				
LEGISLATIVE HISTORY:	N/A				
ENCLOSURES:	<ul style="list-style-type: none"> • Ordinance • Agreement Documents – Intergovernmental Agreement and Consent to Sublease 				
REVIEWS COMPLETED:	Legal	Finance	Purchasing	HR	Other
	X	X			

**AN ORDINANCE APPROVING THE
JOINT INTERGOVERNMENTAL AGREEMENT WITH LOUISA COUNTY
FOR THE
PIEDMONT PUBLIC SAFETY COMMUNICATIONS SYSTEM**

WHEREAS, the Fluvanna County Board of Supervisors is committed to facilitate the provision of public safety and emergency services across the County and to do so in the most economically feasible manner possible; and

WHEREAS, the Counties of Fluvanna and Louisa desire to share certain resources and reduce their individual costs by operating a joint public safety communications system otherwise known as the Piedmont Public Safety Communications System, as such is more specifically described in the Intergovernmental Agreement; and

WHEREAS, such a regional effort will reduce costs and increase operational efficiency, and other localities have also expressed interest in joint, and such efforts may further enhance this effort; and

WHEREAS, as required by Section 15.2-1300 of the Virginia Code, the approval by the Fluvanna County Board of Supervisors of the Intergovernmental Agreement and Consent to Sublease, copies of which are attached and incorporated by reference into this ordinance, by ordinance is necessary to effect moving forward with the Piedmont Public Safety Communications System and project.

NOW, THEREFORE, BE IT ORDAINED, that the Fluvanna County Board of Supervisors hereby (i) agrees to take joint action with Louisa County as set forth in the Intergovernmental Agreement and Consent to Sublease Agreement, and (ii) approves the Intergovernmental Agreement and Consent to Sublease Agreement with Louisa County and further directs the County Administrator to execute these documents after approval as to form by the County Attorney. This ordinance shall take effect upon its adoption.

A Copy teste:

Kelly Belanger Harris, Clerk
Board of Supervisors
Fluvanna County, Virginia

List of Documents for the Intergovernmental Agreement

Shared Piedmont Public Safety Communications System between Fluvanna County and Louisa County

Item	Topic
01	Consent to Sublease Fluvanna
02	Exhibit A - TD Equipment Finance Lease - Fluvanna
03	Exhibit B - Piedmont System Intergovernmental Agreement
04	Appendix A - L2 Core Master Site Diagrams
05	Appendix B - L2 Core Master Site Inventory
06	Appendix C - L2 Core Master Site System Costs
07	Appendix D - Tower Antenna Location Diagrams
08	Appendix E - L2 Core Master Site System Maintenance Costs

CONSENT TO SUBLEASE

This **CONSENT TO SUBLEASE** (this "Consent") is being entered into as of _____, 2018, by and among **TD EQUIPMENT FINANCE, INC.** ("Lessor"), the **COUNTY OF FLUVANNA, VIRGINIA** ("Lessee"), and the **COUNTY OF LOUISA, VIRGINIA** ("Sublessee").

A. Lessor and Lessee are parties to that certain Equipment Lease Purchase Agreement dated October 31, 2016 (the "Lease"), a copy of which is attached hereto as Exhibit A.

B. Lessee desires to lease the sublease a portion of the equipment subject to the Lease (the "Subleased Equipment") to the Sublessee pursuant to that certain Intergovernmental Agreement dated _____, 2018 (the "Sublease"), between Lessee and Sublessee, a copy of which is attached hereto as Exhibit B.

C. Lessee has requested Lessor to consent to the Sublease, and Lessor is willing to provide its consent, subject to the terms and conditions provided below.

NOW THEREFORE, in consideration of the premises and other good and valuable consideration, the receipt and sufficiency of which are hereby acknowledged, and intending to be legally bound hereby, the parties agree as follows:

1. Lessor's Consent. As long as no Event of Default has occurred under the Lease, Lessor hereby consents to Lessee entering into the Sublease with Sublessee with respect to the Subleased Equipment subject to the other provisions of this Consent.

2. Sublease. No provision of the Sublease shall be modified or waived if such modification or waiver either causes the Sublease to be inconsistent with the Lease or this Consent, or impairs Lessor's rights under the Lease or this Consent.

3. Subject and Subordinate. The rights of Sublessee (and any party claiming through Sublessee) with respect to the Subleased Equipment shall be subject and subordinate in all respects to Lessor's rights, title and interests in the Subleased Equipment, including, all of its rights and remedies under the Lease and any related agreements.

4. No Inconsistent Actions. Neither Lessee nor Sublessee will take any action under, or enter into any agreement relating to, the Sublease that conflicts with the Lease or this Consent.

5. Lessee Remains Liable. Lessee agrees that it is and shall remain primarily and fully responsible for all of its obligations under the Lease notwithstanding any provision of the Sublease, including, any agreement by Sublessee to perform its obligations thereunder.

6. Lessee Representations. Lessee hereby certifies that: (a) all of its representations and warranties in the Lease are: true and correct as of the date of this Consent to the extent they remain applicable in terms of time and status, and ratified and confirmed without condition as if made anew, (b) no Event of Default or event which, with the passage of time or the giving of notice or both, would constitute an Event of Default, exists under the Lease; (c) no consent, approval, order or authorization of, or registration or filing with, any third party is required in connection with the execution, delivery and carrying out of this Consent or, if required, has been obtained, and (d) this Consent has been duly authorized, executed and delivered so that it constitutes the legal, valid and binding obligation of Lessee, enforceable in accordance with its terms.

7. Miscellaneous. (a) This Consent may be signed in any number of counterpart copies and by the parties to this Consent on separate counterparts, but all such copies shall constitute one and the same instrument. Delivery of an executed counterpart of a signature page to this Consent by facsimile transmission or electronic mail in portal document (PDF) format shall be effective as delivery of a manually executed counterpart. Any party so executing this Consent by facsimile transmission or electronic mail in PDF format shall promptly deliver a manually executed counterpart, provided that any failure to do so shall not affect the validity of the counterpart executed by facsimile transmission. (b) Except as expressly provided herein, this Consent shall not constitute an amendment, waiver, consent or release with respect to any provision of the Lease.

IN WITNESS WHEREOF, the parties hereto have caused this Consent to be executed by their respective duly authorized representatives as of the date first above written.

TD EQUIPMENT FINANCE, INC.
Lessor

COUNTY OF FLUVANNA, VIRGINIA
Lessee

By: _____
Name:
Title:

By: _____
Name: Steven M. Nichols
Title: County Administrator

LOUISA COUNTY
Sublessee

By: _____
Name: Christian R. Goodwin
Title: County Administrator

EXHIBIT A

Equipment Lease Purchase Agreement

TD EQUIPMENT FINANCE, INC.
1006 Astoria Boulevard
Cherry Hill, New Jersey 08034

Equipment Lease Purchase Agreement
LESSEE: County of Fluvanna, Virginia
AGREEMENT # 1

This Equipment Lease Purchase Agreement (this "Agreement") is a binding contract between TD Equipment Finance, Inc. ("TDEF"), a Maine corporation, and the County of Fluvanna, Virginia, (the "Lessee") a political subdivision of the Commonwealth of Virginia, duly organized and validly existing under of the Commonwealth of Virginia.

1. Agreement: In executing this Agreement, Lessee agrees to rent the equipment described in Exhibit A-1 (the "Tower Equipment") and Exhibit A-2 (the "Mixed Equipment" and collectively with the Tower Equipment, the "Equipment"). Exhibit B sets forth the terms of the Agreement, including the commencement date, which is the date when the term begins and Lessee's obligation to pay rent accrues. Rental Payments (the "Rental Payments") should be paid to TDEF as instructed, and must be paid only out of legally available funds. A portion of each rental payment represents interest and the balance of each Rental Payment represents principal, as shown on Exhibit B. In order to maintain that interest rate, Lessee must comply with the tax covenants described below and file informational federal tax Form 8038-G in a timely manner. If not, each Rental Payment will be increased to compensate for the loss of the tax exemption status which was assumed in the initial interest rate, as set forth in Section 7 below. These are informational returns only and will not require Lessee to pay a tax. Lessee agrees to accept the Equipment, or any portion thereof, as and when delivered, installed and operating to manufacturer's specifications and to execute the Acceptance Certificate, attached hereto as Exhibit D (the "Acceptance Certificate") supplied by TDEF as evidence thereof. To the fullest extent permitted by law, Lessee agrees to hold TDEF harmless from damages, if for any reason, the vendor fails to deliver, or delays in delivery of, the Equipment so ordered or if the Equipment is unsatisfactory for any reason whatsoever. Lessee agrees that any delay in delivery of the Equipment shall not affect the validity of this Agreement or the obligation to make Rental Payments hereunder. Lessee's execution of the Acceptance Certificate shall conclusively establish that the Equipment covered thereby is acceptable to Lessee for all purposes of this Agreement. If Lessee fails or refuses to sign the Acceptance Certificate within a reasonable time, not to exceed five (5) business days, after the Equipment has been delivered, installed and is operating to manufacturer's specifications, TDEF shall have the option of treating this Agreement as cancelled by Lessee and Lessee shall automatically assume all of TDEF'S rights and obligations as purchaser of the Equipment.

2. The Obligation to Make Payments: Rental Payments shall be due and payable as set forth in Exhibit B hereto. The obligation of Lessee to pay Rental Payments hereunder is a current expense of Lessee and not a debt. This obligation is not in contravention of any applicable statutory or regulatory limitations or requirements; nor shall anything contained herein constitute a pledge of the general tax revenues, funds or monies of Lessee. All payments made by or on behalf of Lessee hereunder shall be nonrefundable. Except in the Event of Nonappropriation (hereinafter defined) as set forth in this paragraph, Lessee's obligation to pay such Rental Payments shall be absolute and unconditional, and there will be no abatement or reduction of Rental Payments by Lessee for any reason, including but not limited to, any defense, recoupment, set off, counterclaim, or any claim (real or imaginary) arising out of or related to any defects, damages, malfunctions, breakdowns or infirmities of the Equipment. Following Lessee's signature of the Acceptance Certificate, Lessee assumes and shall bear the entire risk of loss and damage to the Equipment from any cause whatsoever, it being the intention of the parties that the Rental Payments shall be made in all events unless the obligation to make Rental Payments is terminated as otherwise provided herein. Lessee hereby represents and warrants that it has funds available to pay the Rental Payments set forth on Exhibit B through the end of the current fiscal year ("First Appropriation Period"). While recognizing that it is not empowered to make any binding commitment beyond the First Appropriation Period, it is the current intention of Lessee to make sufficient annual appropriations during the Term hereof to pay all Rental Payments and other amounts required to be paid by Lessee under this Agreement. Notwithstanding anything in this Agreement to the contrary, Lessee's obligation to pay the cost and expense of performing its obligations under this Agreement, including without limitation its obligations to pay all Rental Payments and all other amounts required to be paid by Lessee under this Agreement including, without limitation, amounts payable under Section 7 hereof, are subject to and dependent upon appropriations being made from time to time by the Board of Supervisors of the County of Fluvanna, Virginia (the "Governing Body") for such purpose. Lessee directs the County Administrator or any other officer charged with the responsibility of preparing Lessee's budget to include in the budget for each fiscal year of Lessee during the Term hereof a request that the Governing Body appropriate, and otherwise use his or her best efforts to cause the Governing Body to appropriate, in the Fiscal year the amount of Rental Payments and other payments due under this Agreement during such fiscal year. Lessee shall notify TDEF in writing each year during the Term hereof that such budget request has been made as soon as practicable following the submission of Lessee's annual budget to the Governing Body. If at any time during any fiscal year of Lessee, the amount appropriated in the budget of Lessee for the fiscal year is insufficient to pay when due the

Rental Payments and other amounts due under this Lease, Lessee directs the County Administrator (or other officer charged with responsibility for preparing Lessee's budget) to submit to the Governing Body, as appropriate, at the next scheduled meeting of Lessee or the Governing Body, or as promptly as practicable, but in any event within forty-five (45) days, a request for a supplemental appropriation sufficient to cover the deficit. Notwithstanding the foregoing, after the First Appropriation Period, if Lessee has not appropriated sufficient funds to pay TDEF for the Rental Payments, and Lessee shall not have funds duly authorized for the Rental Payments or other amounts payable hereunder from other sources, an Event of Nonappropriation (an "Event of Nonappropriation") shall be deemed to have occurred. Lessee shall promptly deliver notice thereof to TDEF and shall endeavor to give such notice not less than one hundred twenty (120) days prior to the end of the last fiscal year for which an appropriation was made. Such notice shall state that the termination of this Agreement was caused by the failure of Lessee to appropriate moneys to make Rental Payments due hereunder and that Lessee shall promptly, upon the effective date of such termination, return the Equipment as hereinafter provided. If an Event of Nonappropriation has occurred, this Lease shall terminate, in whole, but not in part, as to all Equipment, effective upon the last day of the fiscal year for which funds were appropriated. Upon termination of this Lease as provided in this Section, Lessee shall not be responsible for the payment of any additional Rental Payments coming due in succeeding fiscal years. Lessee shall then, at Lessee's expense, promptly return the Equipment to TDEF to a location specified by TDEF. Lessee agrees that it will not deliberately cause an Event of Nonappropriation so as to permit Lessee to terminate this Agreement in order to acquire any other equipment or obtain funds directly or indirectly to perform essentially the same application for which the Equipment is intended. Should Lessee fail to pay any part of the Rental Payments or any other sum required to be paid herein to TDEF on their due date, TDEF may charge a late payment as provided in Section 17.

3. The Equipment: Lessee agrees and acknowledges that (I) Lessee has selected the Equipment to be acquired by TDEF and rented to Lessee, (II) the Equipment is, and shall at all times be and remain, personal property notwithstanding that the Equipment or any part thereof may now be, or hereafter become, in any manner affixed or attached to, or imbedded in, or permanently resting upon, real property or any building thereon or any fixtures, or attached in any manner to what is permanent by any means of cement, plaster, nails, bolts, screws or otherwise (and upon request of TDEF, Lessee shall obtain, as to any place where the Equipment is located, a waiver from the landlord and mortgagee thereof with respect to any rights they may have in and to the Equipment or the rights of levy or seizure thereon), (III) the Equipment will have a useful life in Lessee's hands that is substantially in excess of the initial term of this Agreement, and (IV) Lessee does not intend to sell, or otherwise dispose of, the Equipment during the term of this Agreement. Lessee may contact the seller of the Equipment directly, as TDEF'S agent, to effect the acquisition of the Equipment. Immediately upon receipt and installation of the Equipment, Lessee shall inspect the Equipment. Unless Lessee gives TDEF written notice of each defect or other proper objection to the Equipment before the execution of the Acceptance Certificate, it shall be conclusively presumed upon execution of an Acceptance Certificate, as between TDEF and Lessee, that Lessee has fully inspected and acknowledged that the Equipment described in the Acceptance Certificate is in good condition and repair, has been properly installed and is performing satisfactorily, and that Lessee is satisfied with and has accepted such Equipment in such good condition and repair. Upon acceptance of the Equipment, Lessee must deliver to TDEF an Acceptance Certificate. A portion of the purchase price for the Equipment shall be deposited by the Lessee in a designated and segregated account in the name of the Lessee in the Virginia State Non-Arbitrage Program ("Virginia SNAP"), to be accessed by the Lessee from time to time in accordance with the rules and procedures of Virginia SNAP for the purchase of the Equipment and related costs. Lessee shall submit an invoice for the Equipment to Virginia SNAP with a copy to TDEF and shall cause Virginia SNAP shall fund the acquisition of the Equipment directly to the Equipment vendor or to Lessee, if such amount has already been paid by Lessee, out of moneys in the such account. Lessee may assert claims and rights that TDEF may have against any manufacturer of the Equipment as well as the agents or dealers of the manufacturer (the "Vendor") of any portion of the Equipment.

Notwithstanding any other provisions of this Agreement, the Equipment does not include (i) any licenses, software, programs or other items that are not assignable by the terms of the related vendor agreement; or (ii) the Tower Equipment upon payment of the Rental Payments and all other amounts payable related thereto as provided in Section 11 hereof. In addition, prior to the return or removal of the Equipment pursuant to Sections 3 or 12 upon a termination of this Agreement, Lessee shall be allowed access to all Equipment for a reasonable period of time to transfer and safeguard any data or other information stored within any such Equipment, or portions thereof.

4. Title to the Equipment; Security Interest: Title to the Equipment and any and all additions, repairs, replacements or modifications thereto, shall be deemed to be vested in Lessee subject to the rights of TDEF hereunder from and after the date of the acceptance of the Equipment so long as Lessee shall not be in default hereunder and/or this Agreement shall not have been terminated pursuant to the provisions of Section 12 hereof, and shall vest permanently in Lessee upon the completion of all Rental Payments or prepayment, free and clear of any lien or security interest of TDEF therein. Immediately upon the occurrence of an Event of Default by Lessee hereunder or the termination of this Agreement under Section 12, title to the Equipment (and all additions, repairs, replacements or modifications thereto) shall revert to TDEF, free and clear of any right, title or interest of Lessee unless TDEF elects otherwise, without the necessity of any further action or the execution of any documents by the parties.

Lessee acknowledges that for federal income tax and accounting purposes and for purposes of Section 7 hereof, equitable title to the Equipment during the term of this Agreement shall be in Lessee, and Lessee further acknowledges that TDEF does not operate, control or have possession of the Equipment and has no control over Lessee or Lessee's operation, use, storage or maintenance of the Equipment.

4a. Security Agreement. To secure all obligations of Lessee hereunder, Lessee hereby grants to TDEF a security interest in any and all of Lessee's right, title and interest in and to this Agreement, the Equipment, together with all related software (embedded therein or otherwise) and general intangibles, and all additions, accessories, attachments and accessions thereto whether furnished by the supplier of the Equipment, all subleases, chattel paper, accounts and security deposits relating thereto, and any and all substitutions, replacements or exchanges for such item of Equipment, and Rental Payments due or to become due hereunder, and in each such case in which Lessee shall from time to time acquire an interest, and any and all proceeds (including insurance proceeds) of the Equipment and other collateral in and against which a security interest is granted hereunder, any and all proceeds thereof, including without limitation, the proceeds of insurance thereon. Lessee will promptly execute, or otherwise authenticate, and deliver to TDEF such further documents, instruments, assurances and other records, and take such further action as TDEF from time to time may reasonably request in order to carry out the intent and purpose of this Agreement and to establish and protect the rights and remedies created or intended to be created in favor of TDEF under such documents (including without limitation (i) lien searches and (ii) such UCC financing statements, fixture filings and waivers as reasonably may be required by TDEF in connection with any change in circumstances relating to Lessee, the Equipment or otherwise); provided, however, Lessee hereby authorizes TDEF to file any and all of the same without Lessee's authentication, to the extent permitted by applicable law. Upon termination of this Lease through exercise of Lessee's option to purchase pursuant to Section 5 or through payment by Lessee of all Rental Payments and, in either case, payment of all amounts relating thereto, and provided Lessee is not in default hereunder, TDEF'S security interest in the Equipment shall terminate, and TDEF shall execute and shall deliver to Lessee such documents as Lessee reasonably may request to evidence the termination of TDEF'S security interest in the Equipment.

5. Option to Purchase: Provided Lessee is not in default hereunder, Lessee shall be entitled to exercise its option to purchase the Equipment: (a) upon payment in full of all Rental Payments in accordance with Exhibit B hereof and all other amounts due hereunder, or (b) in whole, but not in part, on any scheduled payment date, upon written notice delivered at least thirty (30) days in advance of a proposed prepayment date upon payment on such date of the prepayment price equal to the sum of (a) all principal due and remaining unpaid together with interest accrued to such date of prepayment, (b) plus the greater of the Yield Maintenance Fee (as hereinafter defined) or 1% of the principal amount to be prepaid; and (c) all other amounts due and owing hereunder.

The term "Yield Maintenance Fee" is defined as an amount computed as follows: The current cost of funds, specifically the bond equivalent yield for United States Treasury securities (bills on a discounted basis shall be converted to a bond equivalent yield) with a maturity date closest to the "Remaining Term", shall be subtracted from the "Stated Interest Rate". If the result is zero or a negative number, there shall be no Yield Maintenance Fee due and payable. If the result is a positive number, then the resulting percentage shall be multiplied by the amount being prepaid times the number of days in the "Remaining Term" and divided by 360. The resulting amount is the "fixed rate prepayment charge" due to TDEF upon prepayment of the principal of this Agreement plus any accrued interest due as of the prepayment date and is expressed in the following calculation: Yield Maintenance Fee = [Amount Being Prepaid x (Stated Interest Rate - Current Cost of Funds) x Days in the Remaining Term/360 days] + any accrued interest due.

"Remaining Term" as used herein shall mean the shorter of (i) the remaining term of the lease, or (ii) the remaining term of the then current fixed interest rate period. "Stated Interest Rate" as used herein means the rate at which interest is accruing on the outstanding principal balance of the lease at the time of the calculation."

When Lessee exercises its purchase rights hereunder and TDEF shall have received all amounts due under this Agreement, title shall pass simultaneously to Lessee, and this Agreement shall terminate. TDEF shall cooperate and execute such documents that are necessary for the title to the Equipment to vest with Lessee AS IS, WHERE IS, WITHOUT WARRANTIES, EXPRESS OR IMPLIED, INCLUDING WARRANTIES OF MERCHANTABILITY OR FITNESS FOR ANY PARTICULAR PURPOSE OR FITNESS FOR THE USE CONTEMPLATED BY LESSEE, except that the Equipment shall not be subject to any lien created by or arising through TDEF.

6. Responsibilities for Repair and Maintenance: Lessee agrees to maintain the Equipment in good condition and make all necessary repairs and replacements at Lessee's expense. Lessee agrees to maintain a maintenance log for the Equipment and permit TDEF to inspect the Equipment and the log(s) to the extent permitted under applicable law. Lessee must have the Equipment serviced and repaired at Lessee's expense when servicing or repair is required within intervals not exceeding 125% of those recommended in the owner's manual(s).

7. Tax Covenants: Lessee will not make or direct any use of the proceeds of the obligation provided herein or any other funds which will cause such obligation to be an "arbitrage bond" within the meaning of Section 148 of the Internal Revenue Code of 1986, as amended and the treasury regulations promulgated thereunder (the "Code"), to be "federally guaranteed" within the meaning of Section 149 of the Code or to be a "private activity bond" within the meaning of Section 141(a) of the Code. To that end, so long as any Rental Payments are unpaid, Lessee, with respect to such proceeds and such other funds, will comply with all requirements of such Code sections and all regulations of the United States Department of the Treasury issued thereunder to the extent that such requirements are, at the time, applicable and in effect. Furthermore, to the extent applicable pursuant to Section 148(f) of the Code, Lessee covenants to complete or cause to be completed all reporting requirements and rebate all positive arbitrage to the United States of America. Lessee covenants that the Equipment will be used only for the purpose of performing one or more of Lessee's governmental or proprietary functions, and the Equipment will not be used in a trade or business of any person or entity other than Lessee on a basis different from the general public. Lessee will not use or permit the use of the Equipment by any person for a "private business use" within the meaning of Section 141(b) of the Code in such matter or to such extent as would result in the inclusion of interest received hereunder in gross income for federal income tax purposes under Section 103 of the Code.

The parties will cooperate in performing all acts and things legally required or desirable in order to assure that the interest component of the Rental Payments will not be included in the gross income of TDEF or its assigns for federal income tax purposes.

If any event shall occur so that interest payments on this Agreement are includible in the gross income for federal income tax purposes of the recipient of the interest payments on the lease ("Event of Taxability"), Lessee shall pay to TDEF upon demand (x) an amount which, with respect to Rental Payments previously paid and taking into account all penalties, fines, interest and additions to tax (including all federal, state and local taxes imposed on the interest due through the date of such event), will restore to Lessor its after-tax yield hereunder through the date of such event and (y) as additional Rental Payments to TDEF on each succeeding payment date such amount as will maintain such after-tax yield to TDEF.

8. Lessee's Risk of Loss or Damage: Lessee agrees to bear all risk of loss, damage, destruction or theft of the Equipment. Lessee must maintain insurance of the types and in the amounts not less than that set forth on Exhibit C, directing Lessee's insurance company to give TDEF a certificate showing TDEF as lender loss payee and an additional named insured. Lessee must give TDEF prompt notice of (1) the loss, theft or destruction of any part of the Equipment, (2) any damage to the Equipment exceeding \$500, or (3) any claim arising out of the ownership, maintenance, storage or use of the Equipment. The parties will cooperate in deciding if insurance proceeds will be applied to the repair of the Equipment or to its purchase price. If TDEF receives insurance proceeds exceeding the amount of the purchase, plus interest, or the amount required to complete the work, TDEF agrees to forward the excess proceeds to Lessee.

9. Intentionally omitted.

10. No Warranty: Lessee acknowledges and agrees that it has selected each item, type, quality, quantity and supplier of Equipment based upon recommendations of its independent consultants and disclaims any reliance upon any statements or representations made by TDEF, and agrees that the Equipment is of a design, size, quality and capacity required by Lessee and is suitable for its purposes. TDEF MAKES NO EXPRESS OR IMPLIED WARRANTIES CONCERNING THE EQUIPMENT, INCLUDING BUT NOT LIMITED TO MERCHANTABILITY, SUITABILITY OR FITNESS FOR A PARTICULAR USE. THIS SECTION IN NO EVENT IS INTENDED TO AFFECT THE WARRANTIES OR REPRESENTATIONS CONTAINED IN ANY CONTRACT ENTERED INTO FOR THE ACQUISITION OF THE EQUIPMENT, AND, AS TO TDEF, LESSEE LEASES THE EQUIPMENT FROM TDEF AS IS. Notwithstanding the foregoing, TDEF hereby agrees to assign to Lessee, solely for the purpose of making and prosecuting any such claim, all of TDEF's rights, if any, against the manufacturer or supplier of the Equipment for breach of warranty or other representation respecting the Equipment to the extent the same are assignable.

11. Termination: This Agreement will terminate: (1) upon payment of all amounts due hereunder by Lessee to TDEF, (2) at the time and for the reason set forth in Section 2, (3) if Lessee has returned the Equipment and paid all amounts due through the end of the term then in effect, including interest, (4) upon Lessee's purchase of the Equipment under Section 5 and Lessee's payment of all amounts due, (5) at TDEF'S option if Lessee defaults as described in Section 12, and (6) if all or any portion of the Equipment has been lost, stolen or damaged beyond repair, upon TDEF'S receipt of insurance proceeds covering the lost, stolen or damaged Equipment. Lessee and TDEF agree that this Agreement will terminate as to the Tower Equipment upon payment of all scheduled Rental Payments payable through September 1, 2017 and all other amounts then due and payable. Thereafter, this Agreement shall continue subject to the terms hereof with respect to the Mixed Equipment.

12. Default: The following constitute "Events of Default" under this Agreement: (a) failure by Lessee to pay any Rental Payment or other payment required to be paid hereunder, including any late charges, within fifteen (15) days after the due date thereof or (b) failure by Lessee to maintain insurance on the Equipment in accordance with Section 8; or (c) failure by Lessee to observe and perform any other covenant, condition or agreement on its part to be observed or performed for a period of fifteen

(15) days after written notice is given to Lessee by TDEF, specifying such failure and requesting that it be remedied; provided, however, that if the failure stated in such notice cannot be corrected within such fifteen (15) day period, Lessee shall have an extension of time until failure is corrected so long as corrective action is instituted by Lessee within the applicable period and diligently pursued until the default is corrected; or (d) initiation by Lessee of a proceeding under any federal or state bankruptcy or insolvency law seeking relief under such laws concerning its indebtedness; or (e) the determination by TDEF that any representation or warranty made by Lessee in this Lease was untrue in any material respect upon the execution hereof; or (f) (i) Lessee's long term credit or bond rating is lowered by either Moody's Investors Service or Standard & Poor's Rating Services (each a "Rating Agency") greater than four levels (including numeric or other modifiers) from its rating as of the date of this Agreement, respectively, or (ii) Lessee's credit or bond rating is withdrawn by any Rating Agency. If any such default occurs, TDEF, without notice or demand, may declare this Agreement in default and declare all amounts eligible or actually appropriated for Rental Payments under this Agreement to be immediately due and payable. The Equipment must then be returned to TDEF (at the address specified by TDEF) at Lessee's expense, and the Equipment and all Lessee's rights therein shall be deemed surrendered to TDEF. Upon declaration of default and the expiration of any applicable cure period, TDEF may repossess the Equipment with or without process of law, and for the purposes may enter upon any of Lessee's premises or other's premises, wherever the Equipment may be found, subject to applicable law and public policy and subject further to Lessee's rights under Section 3 to transfer and safeguard any data or other information stored within any such Equipment. TDEF may recover from Lessee any unpaid amounts due or to become due for the remainder of the term of this Agreement, together with all expenses, including reasonable attorney's fees and legal expenses (to the extent permitted by law) incurred by TDEF to enforce its rights hereunder. The repossession and sale of the Equipment shall not affect TDEF'S right to recover from Lessee all damages which TDEF has suffered because of Lessee's breach. TDEF may sell or release the Equipment with or without advertisement, at public or private sale or leasing, without notice to Lessee, free of any of Lessee's interest, without any duty to account to Lessee for TDEF'S actions or inaction or for any sale or re-lease proceeds. The proceeds of any sale or re-lease will be applied in the following order: (1) to the proper and reasonable costs and expenses (including reasonable attorney's fees) associated with the default, repossession and restoration of title to TDEF, (2) to pay TDEF the amount of all unpaid Rental Payments, if any, which are then due and owing, together with interest and late charges thereon; then applicable prepayment price (taking into account the payment of past due Rental Payments as aforesaid), plus a *pro rata* allocation of interest, at the rate utilized to establish the interest component for the Rental Payment next due, from the next proceeding due date of a Rental Payment until the date of payment by Lessee, and any other amounts due hereunder, and (3) if any proceeds remain, to Lessee. TDEF may also enforce Lessee's performance of Lessee's covenants to recover damages for the breach of those covenants. TDEF'S rights and remedies in this section are not exclusive but are cumulative and in addition to all other rights and remedies that TDEF has at law or in equity.

For the avoidance of doubt, if Lessee makes all Rental Payments or prepays this Agreement in amounts as indicated in Section 5 and pays all other amounts due and payable hereunder, title to the Equipment shall pass to Lessee and TDEF shall cooperate and execute such documents that are necessary for the title to the Equipment to vest with Lessee.

13. Liens: Lessee shall not directly or indirectly create, incur, assume or suffer to exist any mortgage, pledge, lien, charge, security interest, encumbrance or claim on or with respect to the Equipment or any interest therein, except for the lien and security interest of TDEF therein created under this Agreement. Lessee shall promptly, at its own expense, take such action as may be necessary to duly discharge any such mortgage, pledge, lien, security interest, charge, encumbrance or claim if the same shall arise at any time.

14. Limitation on Assignment: Lessee may not assign or sublease this Agreement or any interest in it or the Equipment without TDEF'S prior written consent and a written opinion of nationally recognized bond counsel to the effect that any such assignment or sublease of this Agreement or any interest in it or the Equipment will not adversely affect the exclusion of the interest component of the Rental Payments from gross income for federal income tax purposes. In no event may Lessee assign or sublet this Agreement or any interest in it or the Equipment to a non-governmental entity. TDEF may assign or sell its interest under this Agreement, in whole or in part, without Lessee's consent. Any assignment will not be effective until Lessee has received notice disclosing the name and address of assignee and information sufficient to enable Lessee to meet the requirements of Section 149(a) of the Code. Lessee shall be provided with written notice of TDEF'S assignment. During the term of this Agreement, Lessee shall keep a complete and accurate register of all such assignments in form necessary to comply with Section 149(a) of the Code. Notwithstanding the foregoing, TDEF understands and consents to the use and possession of the Equipment by the Fluvanna County Sheriff's Office.

15. Late Charges: If Lessee does not make any Rental Payment within 15 days of the due date Lessee shall pay TDEF a late charge of 1% of the overdue amount per month from the due date until the Rental Payment is paid. This late charge is immediately due upon the Rental Payment being late.

16. Exhibits: Exhibits A through H attached hereto are part of this Agreement, incorporated herein by reference, and must be executed by Lessee, where applicable.

17. Other Terms: This Agreement constitutes the entire agreement between the parties as to the subject matter it covers and may not be changed except by a written agreement signed by Lessee and TDEF. If any part of this Agreement is or becomes invalid, illegal or unenforceable, such invalidity, illegality or unenforceability will not affect the other or remaining provisions hereof, which shall remain in effect and construed without regard to such invalid, illegal or unenforceable provision. Titles in this Agreement are inserted solely for convenience and are not to be construed as a limitation on the scope of the provisions to which they refer. This Agreement and all rights and actions arising under it shall be governed by the laws of the Commonwealth of Virginia, without regard to its conflicts of laws principles; and jurisdiction and venue for any dispute hereunder shall be exclusively in the Circuit Court of the County of Fluvanna, Virginia. References herein to any local, Virginia or federal statute shall refer to such statutes, as the same may be amended or replaced by any statute dealing with the same or similar subject matter. No waiver, consent, modification or change of terms of this Agreement shall bind either party unless in writing signed by both parties, and then such waiver, consent, modification or change shall be effective only in the specific instance and for the specific purpose given. This Agreement may be executed in several counterparts. All notices must be addressed to the parties at their addresses shown on Exhibit B, or at another address specified by either party in writing and shall be deemed given when delivered or mailed by registered mail, postage prepaid. To the extent applicable and permissible under applicable law, Lessee hereby waives any and all rights and remedies granted Lessee by Sections 508 through 522 of Article 2A of the Uniform Commercial Code including, by way of example only and not as a limitation, the right to repudiate this Agreement and reject the Equipment; the right to cancel this Agreement; the right to revoke acceptance of the Equipment; the right to grant a security interest in the Equipment in Lessee's possession and control for any reason; the right to recover damages thereunder for any breach of warranty or for any other reason deduct all or any part of the claimed damages resulting from TDEF'S default, if any, under this Agreement; the right to accept partial delivery of the Equipment; the right to "cover" by making any purchase or leases of or contract to purchase or lease Equipment in substitution for those due from TDEF; the right to recover any general, special, incidental or consequential damages, for any reason whatsoever; and the right to specific performance, detinue, sequestration, claim and delivery and the like for the Equipment. The waivers contained herein shall not constitute a waiver by Lessee of any of its rights or remedies against the vendor and/or manufacturer of the Equipment.

18. Lessee Representations and Warranties: Lessee hereby represents, warrants and covenants to TDEF the following with respect to this Agreement as of the date Lessee executes the Acceptance Certificate: (a) Lessee is organized and validly existing under the laws of the Commonwealth of Virginia, with adequate power and capacity to enter into this Agreement, all documents related to the purchase of the Equipment and any other documents required to be delivered in connection with this Agreement or the Equipment (hereinafter "Documents"); (b) Lessee is a political subdivision within the meaning of the Code and will do or cause to be done all things necessary to preserve and keep in full force and effect its existence as such; (c) the Documents have been duly authorized, executed and delivered by Lessee and constitute valid, legal and binding agreements, enforceable in accordance with their terms, except to the extent that the enforcement of remedies therein provided may be limited under applicable bankruptcy and insolvency laws and principles of equity; (d) no approval, consent or withholding of objections is required from any federal, state or local governmental authority or instrumentality with respect to the entry into or performance by Lessee of the Documents, except such as have already been obtained; (e) Lessee has complied with such public bidding requirements as may be applicable to this Agreement and the acquisition of the Equipment hereunder, including without limitation, the provisions of the Virginia Public Procurement Act; (f) the entry into and performance by Lessee of its obligations under the Documents will not (i) violate any judgment, order, law or regulation applicable to Lessee or (ii) result in any breach of, constitute a default under or result in the creation of any lien, charge, security interest or other encumbrance upon any item of the Equipment pursuant to any indenture, mortgage, deed of trust, bank loan or credit agreement or other instrument (other than this Agreement or any purchase money security interest retained by any supplier) to which Lessee is a party; (g) there are no suits or proceedings pending or threatened in court or before any regulatory commission, board or other administrative governmental agency against or affecting Lessee, which will have a material adverse effect on the ability of Lessee to fulfill its obligations under this Agreement; and (h) Lessee has complied with all statutes, laws, regulations and procedures in entering into this Agreement and the matters contemplated hereby.

19. TDEF Representations and Warranties: TDEF represents, covenants and warrants as follows:

- a) TDEF is a corporation duly organized, existing and in good standing under the laws of the State of Maine and is authorized to do business in the Commonwealth of Virginia; has full and complete power to enter into this Agreement, to enter into and to carry out the transactions contemplated by it hereby and thereby and to carry out its obligations under this Agreement, is possessed of full power to own and to hold real and personal property and to lease the same, and has duly authorized the execution and the delivery of this Agreement, and all other agreements, certificates and documents contemplated hereby and thereby.
- b) Neither the execution and the delivery of this Agreement, nor the fulfillment of or the compliance with the terms and the conditions thereof, nor the consummation of the transactions contemplated hereby and thereby conflicts with or results in a breach of the terms, the conditions or the provisions of any restriction, any agreement or any instrument to which TDEF is now a party or by which TDEF or its property is bound, constitutes a default under any of the foregoing that results in the creation or the imposition of any lien, charge or encumbrance whatsoever upon any of the property or the assets of TDEF or upon the Equipment.

c) TDEF hereby conveys, sells, assigns and transfers to the Lessee all rights, title and interest in and to all causes of action it may now have or hereafter acquire under the antitrust laws of the United States or Virginia law, relating to the Equipment. TDEF shall conform to the provisions of the Federal Civil Rights Act of 1964, as amended, as well as the Virginia Fair Employment Act of 1975, as amended, and Section 2.2-4311 and -4312 of the Virginia Procurement Act. TDEF shall retain all books, records and other documents relative to this Agreement for five (5) years after the final payment of all amounts due from Lessee hereunder, or the date of any audit by the Lessee, whichever occurs first.

20. Financing: In consideration for and upon the execution of this Agreement, TDEF hereby agrees to pay to Lessee the amount of \$8,223,125.00, (i) \$1,391,631.43 of which will be deposited by the Lessee in a designated and segregated account in the name of the Lessee in the Virginia SNAP, to be accessed by the Lessee from time to time in accordance with the rules and procedures of Virginia SNAP (subject to the provisions of Section 3 hereof) for the purchase of the Equipment and related costs (ii) \$6,830,493.57 will be applied to pay off the outstanding balance of prior financing provided to Lessee by Motorola Solutions Credit Co., LLC; and (iii) \$1,000.00 will be retained by TDEF as a closing fee.

21. Lessee's General Terms Conditions and Instructions to Bidders and Contractors, RFP and Response. TDEF submitted a response dated September 27, 2016 to a Request for Proposals ("Response") RFP# 2017-01 issued by Lessee (the "RFP") which is the subject of this resulting Agreement. The terms, provisions and requirements of the RFP and Response are incorporated herein by reference as material provisions of this Agreement, including the County of Fluvanna's General Terms, Conditions and Instructions to Bidders and Contractors (the "General Terms") which was incorporated into the RFP. To the extent there is a conflict between the provisions of this Agreement and the RFP, Response or General Terms, this Agreement shall control. Whenever possible, this Agreement and the RFP, Response and General Terms shall be read together. The General Terms are attached hereto Appendix I.

22. Conditions of Closing: At or prior to payment to Lessee as stated in Section 20, TDEF shall have received the following:

- a) this Agreement executed by Lessee and TDEF;
- b) an executed Exhibit B to this Agreement;
- c) an executed Insurance Coverage Requirements Certificate, a form of which is attached hereto as Exhibit C;
- d) an executed Acceptance Certificate, a form of which is attached hereto as Exhibit D;
- e) a duly adopted resolution of Lessee, in form and substance acceptable to TDEF;
- f) an executed Certificate of Lessee, a form of which is attached as Exhibit F;
- g) an executed Arbitrage and Tax Certificate in form and substance satisfactory to TDEF and bond counsel to Lessee;
- h) an opinion of counsel to Lessee, substantially in the form of the opinions attached as Exhibit H;
- i) an executed Form 8038 G; and
- j) any and all opinions, certificates, instruments, financing statements or other documents as TDEF may reasonably request to evidence compliance with this Agreement to be performed and all conditions to be satisfied under this Agreement.

[Signature Page Follows]

IN WITNESS WHEREOF, the undersigned parties have executed this Agreement as of the date first set forth above.

LESSOR:
TD EQUIPMENT FINANCE, INC.

By: _____
Name: _____
Title: _____

LESSEE:
COUNTY OF FLUVANNA, VIRGINIA

By:  _____
Name: Steven M. Nichols
Title: County Administrator

Jurisdiction of Organization: Fluvanna County

Organizational Number: 54-6001282

Chief Executive Office: 132 Main Street Palmyra, Virginia 22963

[Signature Page to Lease Purchase Agreement]

**EXHIBIT A-1
(TOWER EQUIPMENT)**

QTY. MAKE SERIAL NO. MODEL

SEE EQUIPMENT LIST ATTACHED HERETO AND MADE A PART HEREOF

LESSEE INITIALS:



Exhibit A-1
(Tower Equipment List)

1. 300-foot self-supported lattice communication tower located at Central Virginia Electric Cooperative; 31 Cooperative Way, Palmyra, Virginia 22963.

2. 300-foot self-supported lattice communication tower located at Columbia Elementary School; 563 Wilmington Road Palmyra, Virginia 22963.

3. 250-foot self-supported lattice communication tower located at Palmyra Governance Center; 11206 West River Road, Fork Union, Virginia 23055.

**EXHIBIT A-2
(MIXED EQUIPMENT)**

QTY. MAKE SERIAL NO. MODEL

SEE EQUIPMENT LIST ATTACHED HERETO AND MADE A PART HEREOF

LESSEE INITIALS:

ED

Exhibit A-2

(Mixed Equipment List)

1. 195-foot self-supported lattice communication tower located at Fluvanna County Sheriff's Office; 160 Commons Blvd., Palmyra, Virginia 22963.
2. Radio and Communication equipment as per the attached schedules.

DETAILED EQUIPMENT LIST

G.4.1.1 TRUNKING SYSTEM

QTY.	APC CODE	MODEL NUMBER	ITEM DESCRIPTION
1	112	X530BG	ADD: VHF (136-174 MHZ)
1	112	CA01949AA	ADD: ANALOG ONLY CONV SW
1	112	CA01952AA	ADD: ANALOG CONVENTIONAL SIMULCAST
1	112	X153AW	ADD: RACK MOUNT HARDWARE
1	112	DLN6821	FRU: GTR ANALOG 4W E&M SIMULCST KIT
1	207	DQ_FLUPAGECOMB	Paging channel addition to Combiner
1	425	SQM01SUM0274	SINGLE ZONE TRUNKED L CORE
1	425	NPI_001298	CAOXXXXAA - ADD: REDUNDANT CORE
1	425	CA01663AB	ADD: RACK
1	425	UA00137AA	ADD: EMAIL ALARM NOTIFICATIONS
1	425	CA02634AA	ADD: MOSCAD NFM VIRTUAL APP A7.15_A
1	425	UA00225AA	ADD: UEM ENHANCED NAVIGATION
1	425	UA00226AA	ADD: MICROWAVE MAP & SEGMENT VIEW
1	425	UA00227AA	ADD: UEM SNMP ELEMENT MANAGEMENT
1	425	CA01750AA	ADD: TERMINAL SERVER
1	425	CA02635AA	ADD: Fortinet Firewall Appliance
1	425	UA00158AA	ADD: PHASE 2 TDMA TRKG OP ZONE LIC
6	425	UA00159AA	ADD: P25 PHASE 2 TDMA TRKNG OP SITE
1	425	UA00152AA	ADD:500 RADIO USER LICENSES
13	425	CA02193AA	ADD: ANTI-MALWARE DEF UPDATE LIC
1	147	CLN1856	2620-24 ETHERNET SWITCH ?
5	708	T7885	MCAFFEE WINDOWS AV CLIENT
1	469	F4544	SITE MANAGER ADVANCED
1	469	V266	ADD: 90VAC TO 260VAC PS TO SM
1	469	VA00873	ADD: SDM SNT FW CURR ASTRO REL
1	708	TT2539	Z420 HIGH TIER WORKSTATION WINDOWS
1	708	DS019BLK	19 INCH NON-TOUCH MONITOR, BLACK
1	708	TT2177	INTOUCH RUNTIME 60K TAG W/O-I/O, V1
1	708	TT2296	HYPERACCESS VERSION 9.0
1	708	DDN9048	SERIAL/ IP 1 PORT SEAT LICENSE
1	906	DSTRAK88353M	GPS CLOCK, 10MHZ, RUBIDIUM, 48V INC
1	906	DSTRAKP001134	AC POWER SUPPLY FOR 8835 GPS CLOCK
1	906	DSTRAK4008245101	MOUNTING SHELF FOR 8835 GPS CLOCK

QTY.	APC CODE	MODEL NUMBER	ITEM DESCRIPTION
1	906	DSTRAKP002111KIT	ENHANCED FILTER ANTENNA KIT (N CONN
1	430	DVN4046B	MASTER SYSTEM KEY STARTER KIT
2	280	DLN6822	FRE: DL380p G8 HC 300GB DISK
1	280	DLN6864	FRU: DL380 G8p POWER SUPPLY
2	280	DLN6844	CPH 300 GB HARD DRIVE
2	280	DLN6866	DVD DRIVE
1	877	DLN6880	DAS - CHASSIS ONLY
2	877	DLN6879	DAS - PROCESSOR MODULE
2	877	DLN6867	DAS POWER SUPPLY
4	877	CKN6952	SAS CABLE 1M
7	425	DLN6881	1 TB SAS HARD DRIVE
1	708	DSSTBP8000100	SEAGATE : 8TB BUSINESS STORAGE 4-BA
1	877	DLN6692	HP LASERJET PRINTER CP3525DN 110V
1	708	TT2565	NM Z420 HIGH TIER WIN7-IE9 64BIT
1	877	T8123	ASTRO CLIENT APPL SW 7.15
1	708	DS019BLK	19 INCH NON-TOUCH MONITOR, BLACK
1	571	DSHPSUBLAPTOP	LAPTOP WINDOWS
6	708	T7885	MCAFFEE WINDOWS AV CLIENT
1	906	DSTRAK91009E	REMOTE SITE REDUNDANT MODULAR FREQU
50	351	L1700	FSJ1-50A CABLE: 1/4" SUPERFLEX POLY
4	351	DDN9769	TRANSMISSION LINE,F1TNM-HC 1/4IN TY
1	201	T7537	KVL 4000 KEYLOADER
1	201	U239AD	ADD: ASTRO 25 MODE
1	201	QA01767AA	ADD: KVL RADIO AUTHENTICATION
1	201	X795AJ	ADD: ASN MODE
1	201	CA01598AA	ADD: AC LINE CORD US
1	201	CA00182AP	ADD: AES ENCRYPTION SOFTWARE
1	201	X423AF	ADD: DES/DES-XL/DES-OFB ENCRYPTION
1	201	C543	ADD: CABLE FOR RNC, DIU, MGEG
1	201	C724	CABLE, KEYLOAD
1	201	CA01603AA	ADD: USB COMM/CHARGE CABLE W/ CUP
1	514	HKN6182	KEYLOADING CABLE ADAPTER (GCAI)
1	644	TDN9390	KVL CABLE FOR XTS3000 AND MTS2000
1	201	TKN8209	CABLE KEYLOAD MX
2	509	TRN7343	SEVEN AND A HALF FOOT RACK
1	207	DSTSJ100BT	SPD, RJ-48 8 PIN, 10/100 BASE T TSJ
1	207	DSTSJADP	RACK MOUNT GROUND BAR, 19 IN FOR TS
1	430	DVN4046B	MASTER SYSTEM KEY STARTER KIT
1	147	SQM01SUM0205	GGM 8000 GATEWAY
1	147	CA01616AA	ADD: AC POWER
1	147	CLN1856	2620-24 ETHERNET SWITCH

QTY.	APC CODE	MODEL NUMBER	ITEM DESCRIPTION
1	147	CLN1858	3800-48 ETHERNET SWITCH
1	147	T8126	FORTINET FIREWALL APPLIANCE
1	56	DLN6940	460W POWER SUPPLY FOR DL380P
1	660	DLN6967	FRU: 500 GB SATA DRIVE
1	147	T7385	TERMINAL SERVER
1	112	T7321	GCM 8000 COMPARATOR
2	112	CA01183AA	ADD: GCM 8000 COMPARATOR
2	112	CA01185AA	ADD: IP BASED MULTISITE OPERATION
1	112	CA01901AA	ADD: P25 TDMA COMPARATOR SOFTWARE
1	112	X153AW	ADD: RACK MOUNT HARDWARE
1	112	T7321	GCM 8000 COMPARATOR
2	112	CA01183AA	ADD: GCM 8000 COMPARATOR
2	112	CA01185AA	ADD: IP BASED MULTISITE OPERATION
2	112	CA01901AA	ADD: P25 TDMA COMPARATOR SOFTWARE
1	112	X153AW	ADD: RACK MOUNT HARDWARE
1	112	T7038	GCP 8000 SITE CONTROLLER
1	112	CA00303AA	ADD: QTY (1) SITE CONTROLLER
7	112	CA02214AA	ADD: SIMULCAST REMOTE SITE LICENSE
1	112	CA01194AA	ADD: IP BASED MULTISITE SITE CONTRO
1	112	X153AW	ADD: RACK MOUNT HARDWARE
1	112	T7038	GCP 8000 SITE CONTROLLER
1	112	CA00303AA	ADD: QTY (1) SITE CONTROLLER
7	112	CA02214AA	ADD: SIMULCAST REMOTE SITE LICENSE
1	112	CA01194AA	ADD: IP BASED MULTISITE SITE CONTRO
1	112	X153AW	ADD: RACK MOUNT HARDWARE
1	906	DSTRAK91008E	PRIME/MASTER SITE REDUNDANT MODULAR
50	351	L1700	FSJ1-50A CABLE: 1/4" SUPERFLEX POLY
4	351	DDN9769	TRANSMISSION LINE,F1TNM-HC 1/4IN TY
2	147	SQM01SUM0205	GGM 8000 GATEWAY
2	147	CA01616AA	ADD: AC POWER
2	147	CLN1859	2620-48 ETHERNET SWITCH
2	147	SQM01SUM0205	GGM 8000 GATEWAY
2	147	CA01616AA	ADD: AC POWER
2	147	CLN1859	2620-48 ETHERNET SWITCH
1	509	TRN7343	SEVEN AND A HALF FOOT RACK
4	207	DSTSJ100BT	SPD, RJ-48 8 PIN, 10/100 BASE T TSJ
4	207	DSTSJADP	RACK MOUNT GROUND BAR, 19 IN FOR TS
1	147	SQM01SUM0205	GGM 8000 GATEWAY
1	147	CA01616AA	ADD: AC POWER
1	147	CA02086AA	ADD: HIGH DENSITY ENH CONV GATEWAY
1	906	DSTRAK91061	FOUR PORT DDM

QTY.	APC	MODEL	ITEM
	CODE	NUMBER	DESCRIPTION
1	147	SQM01SUM0205	GGM 8000 GATEWAY
1	147	CA01616AA	ADD: AC POWER
1	147	CA02086AA	ADD: HIGH DENSITY ENH CONV GATEWAY
1	112	DLN6892	FRU: XCVR VHF V2
1	112	DLN6897	FRU: PA VHF
1	112	DLN6569	FRU: GCP 8000/GCM 8000
1	112	DLN6781	FRU POWER SUPPLY
1	729	DLN6455	CONFIGURATION/SERVICE SOFTWARE
1	112	DLN6898	FRU: FAN MODULE
2	147	SQM01SUM0205	GGM 8000 GATEWAY
2	147	CA01616AA	ADD: AC POWER
2	147	CLN1856	2620-24 ETHERNET SWITCH ?
4	112	T7039	GTR 8000 Base Radio
4	112	X530BG	ADD: VHF (136-174 MHZ)
4	112	CA01193AA	ADD: IP BASED MULTISITE BASE RADIO
4	112	CA01953AA	ADD: POWER EFFICIENCY PACKAGE
3	112	CA01842AA	ADD: P25 TDMA SOFTWARE
4	112	X153AW	ADD: RACK MOUNT HARDWARE
1	509	TRN7343	SEVEN AND A HALF FOOT RACK
1	207	DSTSJ100BT	SPD, RJ-48 8 PIN, 10/100 BASE T TSJ
1	207	DSTSJADP	RACK MOUNT GROUND BAR, 19 IN FOR TS
2	147	SQM01SUM0205	GGM 8000 GATEWAY
2	147	CA01616AA	ADD: AC POWER
2	147	CLN1856	2620-24 ETHERNET SWITCH
1	906	DSTRAK91009E	REMOTE SITE REDUNDANT MODULAR FREQU
2	906	DSTRAK91061	FOUR PORT DDM
50	351	L1700	FSJ1-50A CABLE: 1/4" SUPERFLEX POLY
4	351	DDN9769	TRANSMISSION LINE,F1TNM-HC 1/4IN TY
4	112	T7039	GTR 8000 Base Radio
4	112	X530BG	ADD: VHF (136-174 MHZ)
4	112	CA01193AA	ADD: IP BASED MULTISITE BASE RADIO
4	112	CA01953AA	ADD: POWER EFFICIENCY PACKAGE
3	112	CA01842AA	ADD: P25 TDMA SOFTWARE
4	112	X153AW	ADD: RACK MOUNT HARDWARE
1	509	TRN7343	SEVEN AND A HALF FOOT RACK
2	207	DSTSJ100BT	SPD, RJ-48 8 PIN, 10/100 BASE T TSJ
2	147	SQM01SUM0205	GGM 8000 GATEWAY
2	147	CA01616AA	ADD: AC POWER
2	147	CLN1856	2620-24 ETHERNET SWITCH
1	906	DSTRAK91009E	REMOTE SITE REDUNDANT MODULAR FREQU
2	906	DSTRAK91061	FOUR PORT DDM

QTY.	APC CODE	MODEL NUMBER	ITEM DESCRIPTION
50	351	L1700	FSJ1-50A CABLE: 1/4" SUPERFLEX POLY
4	351	DDN9769	TRANSMISSION LINE,F1TNM-HC 1/4IN TY
4	112	T7039	GTR 8000 Base Radio
4	112	X530BG	ADD: VHF (136-174 MHZ)
4	112	CA01193AA	ADD: IP BASED MULTISITE BASE RADIO
4	112	CA01953AA	ADD: POWER EFFICIENCY PACKAGE
3	112	CA01842AA	ADD: P25 TDMA SOFTWARE
4	112	X153AW	ADD: RACK MOUNT HARDWARE
1	509	TRN7343	SEVEN AND A HALF FOOT RACK
2	207	DSTSJ100BT	SPD, RJ-48 8 PIN, 10/100 BASE T TSJ
2	147	SQM01SUM0205	GGM 8000 GATEWAY
2	147	CA01616AA	ADD: AC POWER
2	147	CLN1856	2620-24 ETHERNET SWITCH
1	906	DSTRAK91009E	REMOTE SITE REDUNDANT MODULAR FREQU
2	906	DSTRAK91061	FOUR PORT DDM
50	351	L1700	FSJ1-50A CABLE: 1/4" SUPERFLEX POLY
4	351	DDN9769	TRANSMISSION LINE,F1TNM-HC 1/4IN TY
4	112	T7039	GTR 8000 Base Radio
4	112	X530BG	ADD: VHF (136-174 MHZ)
4	112	CA01193AA	ADD: IP BASED MULTISITE BASE RADIO
4	112	CA01953AA	ADD: POWER EFFICIENCY PACKAGE
3	112	CA01842AA	ADD: P25 TDMA SOFTWARE
4	112	X153AW	ADD: RACK MOUNT HARDWARE
1	509	TRN7343	SEVEN AND A HALF FOOT RACK
2	207	DSTSJ100BT	SPD, RJ-48 8 PIN, 10/100 BASE T TSJ
2	147	SQM01SUM0205	GGM 8000 GATEWAY
2	147	CA01616AA	ADD: AC POWER
1	906	DSTRAK88353M	GPS CLOCK, 10MHZ, RUBIDIUM, 48V INC
1	906	DSTRAKP001134	AC POWER SUPPLY FOR 8835 GPS CLOCK
1	906	DSTRAK4008245101	MOUNTING SHELF FOR 8835 GPS CLOCK
1	112	T7038	GCP 8000 SITE CONTROLLER
2	112	CA01536AA	GPB 8000 REFERENCE DISTRIBUTION MOD
2	112	CA01537AC	ADD: RDM SW FOR RX ONLY
1	112	X153AW	ADD: RACK MOUNT HARDWARE
1	112	T7540	GPW 8000 RECEIVER
1	112	X302AR	ADD: QTY 2 GPW 8000 RECEIVER
2	112	X530BH	ADD: VHF (136-174 MHZ)
2	112	CA01193AB	ADD: IP BASED MULTISITE (SIMULCAST)
1	112	CA01953AB	ADD: POWER EFFICIENCY PACKAGE
1	112	CA01842AB	ADD : P25 TDMA RCVR SOFTWARE
1	112	X153AW	ADD: RACK MOUNT HARDWARE

QTY.	APC CODE	MODEL NUMBER	ITEM DESCRIPTION
1	112	T7540	GPW 8000 RECEIVER
1	112	X302AR	ADD: QTY 2 GPW 8000 RECEIVER
2	112	X530BH	ADD: VHF (136-174 MHZ)
2	112	CA01193AB	ADD: IP BASED MULTISITE (SIMULCAST/
1	112	CA01953AB	ADD: POWER EFFICIENCY PACKAGE
2	112	CA01842AB	ADD : P25 TDMA RCVR SOFTWARE
1	112	X153AW	ADD: RACK MOUNT HARDWARE
1	509	TRN7343	SEVEN AND A HALF FOOT RACK
2	207	DSTSJ100BT	SPD, RJ-48 8 PIN, 10/100 BASE T TSJ
2	147	SQM01SUM0205	GGM 8000 GATEWAY
2	147	CA01616AA	ADD: AC POWER
1	906	DSTRAK88353M	GPS CLOCK, 10MHZ, RUBIDIUM, 48V INC
1	906	DSTRAKP001134	AC POWER SUPPLY FOR 8835 GPS CLOCK
1	906	DSTRAK4008245101	MOUNTING SHELF FOR 8835 GPS CLOCK
1	112	T7038	GCP 8000 SITE CONTROLLER
2	112	CA01536AA	GPB 8000 REFERENCE DISTRIBUTION MOD
2	112	CA01537AC	ADD: RDM SW FOR RX ONLY
1	112	X153AW	ADD: RACK MOUNT HARDWARE
1	112	T7540	GPW 8000 RECEIVER
1	112	X302AR	ADD: QTY 2 GPW 8000 RECEIVER
2	112	X530BH	ADD: VHF (136-174 MHZ)
2	112	CA01193AB	ADD: IP BASED MULTISITE (SIMULCAST/
1	112	CA01953AB	ADD: POWER EFFICIENCY PACKAGE
1	112	CA01842AB	ADD : P25 TDMA RCVR SOFTWARE
1	112	X153AW	ADD: RACK MOUNT HARDWARE
1	112	T7540	GPW 8000 RECEIVER
1	112	X302AR	ADD: QTY 2 GPW 8000 RECEIVER
2	112	X530BH	ADD: VHF (136-174 MHZ)
2	112	CA01193AB	ADD: IP BASED MULTISITE (SIMULCAST/
1	112	CA01953AB	ADD: POWER EFFICIENCY PACKAGE
2	112	CA01842AB	ADD : P25 TDMA RCVR SOFTWARE
1	112	X153AW	ADD: RACK MOUNT HARDWARE
1	509	TRN7343	SEVEN AND A HALF FOOT RACK
2	207	DSTSJ100BT	SPD, RJ-48 8 PIN, 10/100 BASE T TSJ
2	147	SQM01SUM0205	GGM 8000 GATEWAY
2	147	CA01616AA	ADD: AC POWER
1	906	DSTRAK88353M	GPS CLOCK, 10MHZ, RUBIDIUM, 48V INC
1	906	DSTRAKP001134	AC POWER SUPPLY FOR 8835 GPS CLOCK
1	906	DSTRAK4008245101	MOUNTING SHELF FOR 8835 GPS CLOCK
1	112	T7038	GCP 8000 SITE CONTROLLER
2	112	CA01536AA	GPB 8000 REFERENCE DISTRIBUTION MOD

QTY.	APC	MODEL	ITEM
	CODE	NUMBER	DESCRIPTION
2	112	CA01537AC	ADD: RDM SW FOR RX ONLY
1	112	X153AW	ADD: RACK MOUNT HARDWARE
1	112	T7540	GPW 8000 RECEIVER
1	112	X302AR	ADD: QTY 2 GPW 8000 RECEIVER
2	112	X530BH	ADD: VHF (136-174 MHZ)
2	112	CA01193AB	ADD: IP BASED MULTISITE (SIMULCAST/
1	112	CA01953AB	ADD: POWER EFFICIENCY PACKAGE
1	112	CA01842AB	ADD : P25 TDMA RCVR SOFTWARE
1	112	X153AW	ADD: RACK MOUNT HARDWARE
1	112	T7540	GPW 8000 RECEIVER
1	112	X302AR	ADD: QTY 2 GPW 8000 RECEIVER
2	112	X530BH	ADD: VHF (136-174 MHZ)
2	112	CA01193AB	ADD: IP BASED MULTISITE (SIMULCAST/
1	112	CA01953AB	ADD: POWER EFFICIENCY PACKAGE
2	112	CA01842AB	ADD : P25 TDMA RCVR SOFTWARE
1	112	X153AW	ADD: RACK MOUNT HARDWARE
1	509	TRN7343	SEVEN AND A HALF FOOT RACK
2	207	DSTSJ100BT	SPD, RJ-48 8 PIN, 10/100 BASE T TSJ
1	469	F4544	SITE MANAGER ADVANCED
1	469	V266	ADD: 90VAC TO 260VAC PS TO SM
1	469	VA00872	ADD: SDM ASTRO RTU FW CURR ASTRO RE
2	469	V592	AAD TERM BLCK & CONN WI
1	382	F4528	GMC_PER_DEVICE_SW_LICENSES
1	382	V809	GMC_SW_LIC_PER_NFM-RTU_I-O
7	382	F2463	RTU_PER_DEVICE_SW_LICENSES
7	382	V839	RTU_SW_LIC_PER_NFM-RTU_I-O
1	469	F4544	SITE MANAGER ADVANCED
1	469	V266	ADD: 90VAC TO 260VAC PS TO SM
1	469	VA00872	ADD: SDM ASTRO RTU FW CURR ASTRO RE
3	469	V592	AAD TERM BLCK & CONN WI
1	382	F4528	GMC_PER_DEVICE_SW_LICENSES
1	382	V809	GMC_SW_LIC_PER_NFM-RTU_I-O
1	382	V838	GMC_SW_LIC_PER_TRAK_GPS
2	382	V283	GMC_SW_LIC_PER_MNI_M-W_RADIO
1	382	F2463	RTU_PER_DEVICE_SW_LICENSES
1	382	V839	RTU_SW_LIC_PER_NFM-RTU_I-O
1	382	V838	RTU_SW_LIC_PER_TRAK_GPS
2	382	V840	RTU_SW_LIC_PER_MNI_M-W_RADIO
2	351	DSF4DRC	1/2" 7-16 DIN MALE RIGHT ANGLE CONN
1	469	F4544	SITE MANAGER ADVANCED
1	469	V266	ADD: 90VAC TO 260VAC PS TO SM

QTY.	APC	MODEL	ITEM
	CODE	NUMBER	DESCRIPTION
1	469	VA00872	ADD: SDM ASTRO RTU FW CURR ASTRO RE
3	469	V592	AAD TERM BLCK & CONN WI
1	382	F4528	GMC_PER_DEVICE_SW_LICENSES
1	382	V809	GMC_SW_LIC_PER_NFM-RTU_I-O
1	382	V838	GMC_SW_LIC_PER_TRAK_GPS
2	382	V283	GMC_SW_LIC_PER_MNI_M-W_RADIO
1	382	F2463	RTU_PER_DEVICE_SW_LICENSES
1	382	V839	RTU_SW_LIC_PER_NFM-RTU_I-O
1	382	V838	RTU_SW_LIC_PER_TRAK_GPS
2	382	V840	RTU_SW_LIC_PER_MNI_M-W_RADIO
2	351	DSF4DRC	1/2" 7-16 DIN MALE RIGHT ANGLE CONN
1	469	F4544	SITE MANAGER ADVANCED
1	469	V266	ADD: 90VAC TO 260VAC PS TO SM
1	469	VA00872	ADD: SDM ASTRO RTU FW CURR ASTRO RE
3	469	V592	AAD TERM BLCK & CONN WI
1	382	F4528	GMC_PER_DEVICE_SW_LICENSES
1	382	V809	GMC_SW_LIC_PER_NFM-RTU_I-O
1	382	V838	GMC_SW_LIC_PER_TRAK_GPS
2	382	V283	GMC_SW_LIC_PER_MNI_M-W_RADIO
1	382	F2463	RTU_PER_DEVICE_SW_LICENSES
1	382	V839	RTU_SW_LIC_PER_NFM-RTU_I-O
1	382	V838	RTU_SW_LIC_PER_TRAK_GPS
2	382	V840	RTU_SW_LIC_PER_MNI_M-W_RADIO
2	351	DSF4DRC	1/2" 7-16 DIN MALE RIGHT ANGLE CONN
1	469	F4544	SITE MANAGER ADVANCED
1	469	V266	ADD: 90VAC TO 260VAC PS TO SM
1	469	VA00872	ADD: SDM ASTRO RTU FW CURR ASTRO RE
3	469	V592	AAD TERM BLCK & CONN WI
1	382	F4528	GMC_PER_DEVICE_SW_LICENSES
1	382	V809	GMC_SW_LIC_PER_NFM-RTU_I-O
1	382	V838	GMC_SW_LIC_PER_TRAK_GPS
2	382	V283	GMC_SW_LIC_PER_MNI_M-W_RADIO
1	382	F2463	RTU_PER_DEVICE_SW_LICENSES
1	382	V839	RTU_SW_LIC_PER_NFM-RTU_I-O
1	382	V838	RTU_SW_LIC_PER_TRAK_GPS
2	382	V840	RTU_SW_LIC_PER_MNI_M-W_RADIO
2	351	DSF4DRC	1/2" 7-16 DIN MALE RIGHT ANGLE CONN
1	469	F4544	SITE MANAGER ADVANCED
1	469	V266	ADD: 90VAC TO 260VAC PS TO SM
1	469	VA00872	ADD: SDM ASTRO RTU FW CURR ASTRO RE
3	469	V592	AAD TERM BLCK & CONN WI

QTY.	APC	MODEL	ITEM
	CODE	NUMBER	DESCRIPTION
1	382	F4528	GMC_PER_DEVICE_SW_LICENSES
1	382	V809	GMC_SW_LIC_PER_NFM-RTU_I-O
1	382	V838	GMC_SW_LIC_PER_TRAK_GPS
2	382	V283	GMC_SW_LIC_PER_MNI_M-W_RADIO
1	382	F2463	RTU_PER_DEVICE_SW_LICENSES
1	382	V839	RTU_SW_LIC_PER_NFM-RTU_I-O
1	382	V838	RTU_SW_LIC_PER_TRAK_GPS
2	382	V840	RTU_SW_LIC_PER_MNI_M-W_RADIO
1	469	F4544	SITE MANAGER ADVANCED
1	469	V266	ADD: 90VAC TO 260VAC PS TO SM
1	469	VA00872	ADD: SDM ASTRO RTU FW CURR ASTRO RE
3	469	V592	AAD TERM BLCK & CONN WI
1	382	F4528	GMC_PER_DEVICE_SW_LICENSES
1	382	V809	GMC_SW_LIC_PER_NFM-RTU_I-O
1	382	V838	GMC_SW_LIC_PER_TRAK_GPS
2	382	V283	GMC_SW_LIC_PER_MNI_M-W_RADIO
1	382	F2463	RTU_PER_DEVICE_SW_LICENSES
1	382	V839	RTU_SW_LIC_PER_NFM-RTU_I-O
1	382	V838	RTU_SW_LIC_PER_TRAK_GPS
2	382	V840	RTU_SW_LIC_PER_MNI_M-W_RADIO
1	469	F4544	SITE MANAGER ADVANCED
1	469	V266	ADD: 90VAC TO 260VAC PS TO SM
1	469	VA00872	ADD: SDM ASTRO RTU FW CURR ASTRO RE
3	469	V592	AAD TERM BLCK & CONN WI
1	382	F4528	GMC_PER_DEVICE_SW_LICENSES
1	382	V809	GMC_SW_LIC_PER_NFM-RTU_I-O
1	382	V838	GMC_SW_LIC_PER_TRAK_GPS
2	382	V283	GMC_SW_LIC_PER_MNI_M-W_RADIO
1	382	F2463	RTU_PER_DEVICE_SW_LICENSES
1	382	V839	RTU_SW_LIC_PER_NFM-RTU_I-O
1	382	V838	RTU_SW_LIC_PER_TRAK_GPS
2	382	V840	RTU_SW_LIC_PER_MNI_M-W_RADIO
4	443	B1933	MOTOROLA VOICE PROCESSOR MODULE
1	443	B1905	MCC 7500 ASTRO 25 SOFTWARE
4	443	CA01642AA	ADD: MCC 7500 BASIC CONSOLE FUNCTIO
4	443	CA01644AA	ADD: MCC 7500 /MCC 7100 ADV CONVL O
4	443	CA01643AA	ADD: MCC 7500 / MCC 7100 TRUNKING
4	443	CA00147AF	ADD: MCC 7500 SECURE OPERATION
4	443	CA00143AC	ADD: DES-OFB ALGORITHM
4	443	CA00182AB	ADD: AES ALGORITHM
4	443	CA00140AA	ADD: AC LINE CORD, NORTH AMERICAN

QTY.	APC	MODEL	ITEM
	CODE	NUMBER	DESCRIPTION
4	708	DSE686772	ELO 1928L 19IN LCD TOUCH MONITOR, D
4	708	TT2538	Z420 LOW TIER WORKSTATION WINDOWS 7
4	877	T7448	WINDOWS SUPPLEMENTAL FULL CONFIG
4	207	DSRMP615A	SPD, TYPE 3, 120V RACK MOUNT, 15A P
16	443	B1912	MCC SERIES DESKTOP SPEAKER
4	443	B1914	MCC SERIES DESKTOP GOOSENECK MICROP
8	443	B1913	MCC SERIES HEADSET JACK
8	706	RLN6098	HDST MODULE BASE W/PTT, 15' CBL
8	706	RMN5078B	SUPRAPLUS NC SINGLE MUFF HEADSET
4	708	DSTWIN6328A	PROVIDES ONE DUAL PEDAL FOOTSWITCH
4	708	T7885	MCAFFEE WINDOWS AV CLIENT
4	229	DDN1611	DUAL IRR SW USB HASP WITH LICENSE (
4	229	DDN1895	SOUND BLASTER AUDIGY RX SOUND CARD
4	708	CDN6673	CREATIVE LABS INSPIRE A60
1	708	MOTOIP	NICE IP LOGGING RECORDER
1	469	F4543	SITE MANAGER BASIC
1	469	VA00874	ADD: AUX I-O SERV FW CURR ASTRO REL
1	469	V266	ADD: 90VAC TO 260VAC PS TO SM
3	469	V592	AAD TERM BLCK & CONN WI
1	443	BVN1013	MKM 7000 Console Alias Manager Soft
1	708	TT2538	Z420 LOW TIER WORKSTATION WINDOWS 7
1	708	T7885	MCAFFEE WINDOWS AV CLIENT
2	509	TRN7343	SEVEN AND A HALF FOOT RACK
2	207	DSTSJ100BT	SPD, RJ-48 8 PIN, 10/100 BASE T TSJ
1	207	DSTSJADP	RACK MOUNT GROUND BAR, 19 IN FOR TS
1	443	B1912	MCC SERIES DESKTOP SPEAKER
1	443	B1914	MCC SERIES DESKTOP GOOSENECK MICROP
1	443	B1913	MCC SERIES HEADSET JACK
4	761	L30KSS9PW1 N	APX7500 SINGLE BAND VHF MID PO
4	761	G806	ADD: ASTRO? DIGITAL CAI OPERATION
4	761	G51	ENH: SMARTZONE OPERATION APX
4	761	G361	ADD: P25 TRUNKING SOFTWARE
4	761	GA00580	ADD: TDMA OPERATION
4	761	G851	ADD: AES/DES-XL/DES-OFB ENCRYPTION
4	761	W969	ADD: MULTIPLE KEY ENCRYPTION OPERAT
4	761	W12	ADD: RF PREAMP
4	761	L998	ADD: LIMITED FRONT PANEL W/CLOCK/VU
4	761	G90	ADD: NO MICROPHONE NEEDED
4	761	CA01598	ADD: AC LINE CORD US
4	185	GA00232	ENH: 3 YR SFS LITE
50	755	H98UCF9PW6 N	APX6000 700/800 MODEL 2.5 PORTABLE

QTY.	APC	MODEL	ITEM
	CODE	NUMBER	DESCRIPTION
50	755	QA02756	ADD: 9600 TRUNKING OR 3600 DIGITAL
50	755	QA00580	ADD: TDMA OPERATION
50	755	H301	DEL: DELETE BELT CLIP/BASIC CARRY H
50	755	QA01833	ADD: EXTREME 1-SIDED NOISE REDUCTIO
50	755	QA01427	ALT: IMPACT GREEN HOUSING
50	185	H885BK	ENH: 2 YR SFS LITE
50	372	HMN4101B	IMPRES RSM NO DSPLY W JACK, NO CHNL
50	271	PMLN5657B	APX6000 CC 2.75 SWLBL 2900&2150MAH
50	785	WPLN7080	APX 7000 IMPRES CG SU APX7000 US/NA
50	755	H98UCF9PW6 N	APX6000 700/800 MODEL 2.5 PORTABLE
50	755	QA02756	ADD: 9600 TRUNKING OR 3600 DIGITAL
50	755	QA00580	ADD: TDMA OPERATION
50	755	H301	DEL: DELETE BELT CLIP/BASIC CARRY H
50	755	QA01833	ADD: EXTREME 1-SIDED NOISE REDUCTIO
50	755	QA01427	ALT: IMPACT GREEN HOUSING
50	755	QA01833	ADD: EXTREME 1-SIDED NOISE REDUCTIO
50	185	H885BK	ENH: 2 YR SFS LITE
50	372	HMN4101B	IMPRES RSM NO DSPLY W JACK, NO CHNL
50	271	PMLN5657B	APX6000 CC 2.75 SWLBL 2900&2150MAH
50	785	WPLN7080	APX 7000 IMPRES CG SU APX7000 US/NA
50	755	H98UCF9PW6 N	APX6000 700/800 MODEL 2.5 PORTABLE
50	755	QA02756	ADD: 9600 TRUNKING OR 3600 DIGITAL
50	755	QA00580	ADD: TDMA OPERATION
50	755	H301	DEL: DELETE BELT CLIP/BASIC CARRY H
50	755	QA01833	ADD: EXTREME 1-SIDED NOISE REDUCTIO
50	755	QA01427	ALT: IMPACT GREEN HOUSING
50	185	H885BK	ENH: 2 YR SFS LITE
50	372	HMN4101B	IMPRES RSM NO DSPLY W JACK, NO CHNL
50	271	PMLN5657B	APX6000 CC 2.75 SWLBL 2900&2150MAH
50	785	WPLN7080	APX 7000 IMPRES CG SU APX7000 US/NA
13	755	H98UCF9PW6 N	APX6000 700/800 MODEL 2.5 PORTABLE
13	755	QA02756	ADD: 9600 TRUNKING OR 3600 DIGITAL
13	755	QA00580	ADD: TDMA OPERATION
13	755	H301	DEL: DELETE BELT CLIP/BASIC CARRY H
13	755	QA01833	ADD: EXTREME 1-SIDED NOISE REDUCTIO
13	755	QA01427	ALT: IMPACT GREEN HOUSING
13	185	H885BK	ENH: 2 YR SFS LITE
13	372	HMN4101B	IMPRES RSM NO DSPLY W JACK, NO CHNL
13	271	PMLN5657B	APX6000 CC 2.75 SWLBL 2900&2150MAH
13	785	WPLN7080	APX 7000 IMPRES CG SU APX7000 US/NA
50	755	H98UCF9PW6 N	APX6000 700/800 MODEL 2.5 PORTABLE

QTY.	APC	MODEL	ITEM
	CODE	NUMBER	DESCRIPTION
50	755	QA02756	ADD: 9600 TRUNKING OR 3600 DIGITAL
50	755	QA00580	ADD: TDMA OPERATION
50	755	H301	DEL: DELETE BELT CLIP/BASIC CARRY H
50	755	QA01833	ADD: EXTREME 1-SIDED NOISE REDUCTIO
50	755	QA01427	ALT: IMPACT GREEN HOUSING
50	185	H885BK	ENH: 2 YR SFS LITE
50	372	HMN4101B	IMPRES RSM NO DSPLY W JACK, NO CHNL
50	271	PMLN5657B	APX6000 CC 2.75 SWLBL 2900&2150MAH
50	785	WPLN7080	APX 7000 IMPRES CG SU APX7000 US/NA
15	755	H98UCF9PW6 N	APX6000 700/800 MODEL 2.5 PORTABLE
15	755	QA02756	ADD: 9600 TRUNKING OR 3600 DIGITAL
15	755	QA00580	ADD: TDMA OPERATION
15	755	H301	DEL: DELETE BELT CLIP/BASIC CARRY H
15	755	QA01833	ADD: EXTREME 1-SIDED NOISE REDUCTIO
15	755	QA01427	ALT: IMPACT GREEN HOUSING
15	185	H885BK	ENH: 2 YR SFS LITE
15	372	HMN4101B	IMPRES RSM NO DSPLY W JACK, NO CHNL
15	271	PMLN5657B	APX6000 CC 2.75 SWLBL 2900&2150MAH
15	785	WPLN7080	APX 7000 IMPRES CG SU APX7000 US/NA
6	655	H97TGD9PW1 N	APX7000 DIGITAL PORTABLE RADIO
6	655	QA00570	ADD: VHF PRIMARY BAND
6	655	QA00573	ADD: 7/800MHZ SECONDARY BAND
6	655	QA00579	ADD: ENABLE DUAL BAND OPERATION
6	655	Q806	ADD: ASTRO? DIGITAL CAI OPERATION
6	655	H38	ADD: SMARTZONE OPERATION
6	655	Q361	ADD: P25 9600 BAUD TRUNKING
6	655	QA00580	ADD: TDMA OPERATION
6	655	QA01833	ADD: EXTREME 1-SIDED NOISE REDUCTIO
6	185	Q58	ADD: 2 YR REPAIR SERVICE ADVANTAGE
6	655	QA01427	ALT: IMPACT GREEN HOUSING
6	271	PMLN5324C	LEATHER CASE 2.75 SWL BL 2500MAH
6	372	HMN4101B	IMPRES RSM NO DSPLY W JACK, NO CHNL
6	785	WPLN7080	APX 7000 IMPRES CG SU APX7000 US/NA
32	755	H98UCF9PW6 N	APX6000 700/800 MODEL 2.5 PORTABLE
32	755	QA02756	ADD: 9600 TRUNKING OR 3600 DIGITAL
32	755	QA00580	ADD: TDMA OPERATION
32	755	H301	DEL: DELETE BELT CLIP/BASIC CARRY H
32	755	QA01833	ADD: EXTREME 1-SIDED NOISE REDUCTIO
32	755	Q629	ENH: AES ENCRYPTION
32	185	H885BK	ENH: 2 YR SFS LITE
32	271	PMLN5657B	APX6000 CC 2.75 SWLBL 2900&2150MAH

QTY.	APC	MODEL	ITEM
	CODE	NUMBER	DESCRIPTION
32	785	WPLN7080	APX 7000 IMPRES CG SU APX7000 US/NA
6	655	H97TGD9PW1 N	APX7000 DIGITAL PORTABLE RADIO
6	655	QA00570	ADD: VHF PRIMARY BAND
6	655	QA00573	ADD: 7/800MHZ SECONDARY BAND
6	655	QA00579	ADD: ENABLE DUAL BAND OPERATION
6	655	Q806	ADD: ASTRO? DIGITAL CAI OPERATION
6	655	H38	ADD: SMARTZONE OPERATION
6	655	Q361	ADD: P25 9600 BAUD TRUNKING
6	655	Q629	ENH: AES ENCRYPTION
6	655	QA00580	ADD: TDMA OPERATION
6	655	QA01833	ADD: EXTREME 1-SIDED NOISE REDUCTIO
6	185	Q58	ADD: 2 YR REPAIR SERVICE ADVANTAGE
6	655	QA01427	ALT: IMPACT GREEN HOUSING
6	271	PMLN5324C	LEATHER CASE 2.75 SWL BL 2500MAH
6	785	WPLN7080	APX 7000 IMPRES CG SU APX7000 US/NA
10	755	H98UCF9PW6 N	APX6000 700/800 MODEL 2.5 PORTABLE
10	755	QA02756	ADD: 9600 TRUNKING OR 3600 DIGITAL
10	755	QA00580	ADD: TDMA OPERATION
10	755	H301	DEL: DELETE BELT CLIP/BASIC CARRY H
10	755	QA01833	ADD: EXTREME 1-SIDED NOISE REDUCTIO
10	755	Q629	ENH: AES ENCRYPTION
10	185	H885BK	ENH: 2 YR SFS LITE
9	755	H98UCF9PW6 N	APX6000 700/800 MODEL 2.5 PORTABLE
9	755	QA02756	ADD: 9600 TRUNKING OR 3600 DIGITAL
9	755	QA00580	ADD: TDMA OPERATION
9	755	H301	DEL: DELETE BELT CLIP/BASIC CARRY H
9	755	QA01833	ADD: EXTREME 1-SIDED NOISE REDUCTIO
9	755	Q629	ENH: AES ENCRYPTION
9	185	H885BK	ENH: 2 YR SFS LITE
9	372	PMMN4062A	APX7000 IMPRES RSM, NOISE CANC. EME
9	785	WPLN7080	APX 7000 IMPRES CG SU APX7000 US/NA
4	755	H98UCF9PW6 N	APX6000 700/800 MODEL 2.5 PORTABLE
4	755	QA02756	ADD: 9600 TRUNKING OR 3600 DIGITAL
4	755	QA00580	ADD: TDMA OPERATION
4	755	H301	DEL: DELETE BELT CLIP/BASIC CARRY H
4	755	QA01833	ADD: EXTREME 1-SIDED NOISE REDUCTIO
4	755	Q629	ENH: AES ENCRYPTION
4	185	H885BK	ENH: 2 YR SFS LITE
4	372	PMMN4062A	APX7000 IMPRES RSM, NOISE CANC. EME
4	785	WPLN7080	APX 7000 IMPRES CG SU APX7000 US/NA
50	471	M22KSS9PW1 N	APX4500 VHF

QTY.	APC CODE	MODEL NUMBER	ITEM DESCRIPTION
50	471	QA02756	ADD: 3600 OR 9600 TRUNKING BAUD SIN
50	471	GA00580	ADD: TDMA OPERATION
50	471	GA00804	ADD: APX O2 CONTROL HEAD (Green)
50	471	G444	ADD: APX CONTROL HEAD SOFTWARE
50	471	G66	ADD: DASH MOUNT O2 WWM
50	471	W22	ADD: PALM MICROPHONE
50	185	G24	ENH: 2 YEAR REPAIR SERVICE ADVANTAG
50	471	G300	ADD: 1/4 WAVE ROOF TOP ANT VHF
50	471	B18	ADD: AUXILARY SPKR 7.5 WATT
24	471	M22KSS9PW1 N	APX4500 VHF
24	471	QA02756	ADD: 3600 OR 9600 TRUNKING BAUD SIN
24	471	GA00580	ADD: TDMA OPERATION
24	471	GA00804	ADD: APX O2 CONTROL HEAD (Green)
24	471	G444	ADD: APX CONTROL HEAD SOFTWARE
24	471	G66	ADD: DASH MOUNT O2 WWM
24	471	W22	ADD: PALM MICROPHONE
24	185	G24	ENH: 2 YEAR REPAIR SERVICE ADVANTAG
24	471	G300	ADD: 1/4 WAVE ROOF TOP ANT VHF
24	471	B18	ADD: AUXILARY SPKR 7.5 WATT
1	471	M22KSS9PW1 N	APX4500 VHF
1	471	QA02756	ADD: 3600 OR 9600 TRUNKING BAUD SIN
1	471	GA00580	ADD: TDMA OPERATION
1	471	GA00804	ADD: APX O2 CONTROL HEAD (Green)
1	471	G444	ADD: APX CONTROL HEAD SOFTWARE
1	471	G66	ADD: DASH MOUNT O2 WWM
1	471	W22	ADD: PALM MICROPHONE
1	185	G24	ENH: 2 YEAR REPAIR SERVICE ADVANTAG
1	471	G300	ADD: 1/4 WAVE ROOF TOP ANT VHF
1	471	B18	ADD: AUXILARY SPKR 7.5 WATT
8	471	M22KSS9PW1 N	APX4500 VHF
8	471	QA02756	ADD: 3600 OR 9600 TRUNKING BAUD SIN
8	471	GA00580	ADD: TDMA OPERATION
8	471	GA00804	ADD: APX O2 CONTROL HEAD (Green)
8	471	G444	ADD: APX CONTROL HEAD SOFTWARE
8	471	G67	ADD: REMOTE MOUNT O2 WWM
8	471	W22	ADD: PALM MICROPHONE
8	185	G24	ENH: 2 YEAR REPAIR SERVICE ADVANTAG
8	471	G300	ADD: 1/4 WAVE ROOF TOP ANT VHF
8	471	B18	ADD: AUXILARY SPKR 7.5 WATT
5	527	M25KSS9PW1 N	APX6500 VHF MID POWER
5	527	G806	ADD: ASTRO? DIGITAL CAI OPERATION

QTY.	APC CODE	MODEL NUMBER	ITEM DESCRIPTION
5	527	G51	ENH: SMARTZONE OPERATION APX6500
5	527	GA00580	ADD: TDMA OPERATION
5	527	G442	ADD: O5 CONTROL HEAD
5	527	G444	ADD: APX CONTROL HEAD SOFTWARE
5	527	G67	ADD: REMOTE MOUNT MID POWER
5	527	G300	ADD:1/4 WAVE ROOF TOP ANT VHF
10	527	W22	ADD: PALM MICROPHONE
10	527	B18	ADD: AUXILARY SPKR 7.5 WATT
5	185	G24	ENH: 2 YEAR REPAIR SERVICE ADVANTAG
5	527	GA00092	ADD: DUAL-CONTRL HD HARDWARE
10	527	G628	ADD: REMOTE MOUNT CBL 17 FEET
46	471	M22KSS9PW1 N	APX4500 VHF
46	471	QA02756	ADD: 3600 OR 9600 TRUNKING BAUD SIN
46	471	GA00580	ADD: TDMA OPERATION
46	471	GA00804	ADD: APX O2 CONTROL HEAD (Green)
46	471	G444	ADD: APX CONTROL HEAD SOFTWARE
46	471	G66	ADD: DASH MOUNT O2 WWM
46	471	W22	ADD: PALM MICROPHONE
46	471	G843	ADD: AES ENCRYPTION APX
46	185	G24	ENH: 2 YEAR REPAIR SERVICE ADVANTAG
46	471	G300	ADD: 1/4 WAVE ROOF TOP ANT VHF
46	471	B18	ADD: AUXILARY SPKR 7.5 WATT
1	471	M22KSS9PW1 N	APX4500 VHF
1	471	QA02756	ADD: 3600 OR 9600 TRUNKING BAUD SIN
1	471	GA00580	ADD: TDMA OPERATION
1	471	GA00804	ADD: APX O2 CONTROL HEAD (Green)
1	471	G444	ADD: APX CONTROL HEAD SOFTWARE
1	471	G66	ADD: DASH MOUNT O2 WWM
1	471	W22	ADD: PALM MICROPHONE
1	471	G843	ADD: AES ENCRYPTION APX
1	185	G24	ENH: 2 YEAR REPAIR SERVICE ADVANTAG
1	471	G300	ADD: 1/4 WAVE ROOF TOP ANT VHF
1	471	B18	ADD: AUXILARY SPKR 7.5 WATT
8	471	M22KSS9PW1 N	APX4500 VHF
8	471	QA02756	ADD: 3600 OR 9600 TRUNKING BAUD SIN
8	471	GA00580	ADD: TDMA OPERATION
8	471	GA00804	ADD: APX O2 CONTROL HEAD (Green)
8	471	G444	ADD: APX CONTROL HEAD SOFTWARE
8	471	G66	ADD: DASH MOUNT O2 WWM
8	471	W22	ADD: PALM MICROPHONE
8	471	G843	ADD: AES ENCRYPTION APX

QTY.	APC	MODEL	ITEM
	CODE	NUMBER	DESCRIPTION
8	185	G24	ENH: 2 YEAR REPAIR SERVICE ADVANTAG
8	471	G300	ADD: 1/4 WAVE ROOF TOP ANT VHF
8	471	B18	ADD: AUXILARY SPKR 7.5 WATT
14	471	M22KSS9PW1 N	APX4500 VHF
14	471	QA02756	ADD: 3600 OR 9600 TRUNKING BAUD SIN
14	471	GA00580	ADD: TDMA OPERATION
14	471	QA02018	ADD: ADVANCED WACN KEY SUPP DATA
14	471	GA00804	ADD: APX O2 CONTROL HEAD (Green)
14	471	G444	ADD: APX CONTROL HEAD SOFTWARE
14	471	G66	ADD: DASH MOUNT O2 WWM
14	471	W382	ADD: CONTROL STATION DESK GCAI MIC
14	185	G24	ENH: 2 YEAR REPAIR SERVICE ADVANTAG
14	471	G142	ADD: NO SPEAKER NEEDED
14	471	G91	ADD: CONTROL STATION POWER SUPPLY
14	471	W665	ADD: BASE STATION APEXWWM
14	351	DSBA10121	ANTENNA BASE STA OMDIR 144-162MHZ F
1120	351	L1705	LDF4-50A CABLE: 1/2" LDF HELIAX POL
28	351	DDN1089	L4TNF-PSA TYPE N FEMALE PS FOR 1/2
14	207	DSIS50NXC2MA	RF SPD, 125-1000MHZ DC BLOCK FLANGE
14	351	DSGKSUNV	GK-SUNV SMALL UNIVERSAL GROUNDING K
140	351	L1700	FSJ1-50A CABLE: 1/4" SUPERFLEX POLY
14	351	DDN9769	F1TNM-HC 1/4" TYPE N MALE CONNECTO
14	351	DSBA10121	ANTENNA BASE STA OMDIR 144-162MHZ F
1120	351	L1705	LDF4-50A CABLE: 1/2" LDF HELIAX POL
28	351	DDN1089	L4TNF-PSA TYPE N FEMALE PS FOR 1/2
14	207	DSIS50NXC2MA	RF SPD, 125-1000MHZ DC BLOCK FLANGE
14	351	DSGKSUNV	GK-SUNV SMALL UNIVERSAL GROUNDING K
140	351	L1700	FSJ1-50A CABLE: 1/4" SUPERFLEX POLY
28	351	DDN9769	F1TNM-HC 1/4" TYPE N MALE CONNECTO
4	471	M22KSS9PW1 N	APX4500 VHF
4	471	QA02756	ADD: 3600 OR 9600 TRUNKING BAUD SIN
4	471	GA00580	ADD: TDMA OPERATION
4	471	GA00804	ADD: APX O2 CONTROL HEAD (Green)
4	471	G444	ADD: APX CONTROL HEAD SOFTWARE
4	471	G66	ADD: DASH MOUNT O2 WWM
4	471	W382	ADD: CONTROL STATION DESK GCAI MIC
4	185	G24	ENH: 2 YEAR REPAIR SERVICE ADVANTAG
4	471	G142	ADD: NO SPEAKER NEEDED
4	471	GA01056	ADD: SCHOOL SERCURITY ENHANCEMENT P
4	471	G91	ADD: CONTROL STATION POWER SUPPLY
4	471	W665	ADD: BASE STATION APEXWWM

QTY.	APC	MODEL	ITEM
	CODE	NUMBER	DESCRIPTION
4	471	G91	ADD: CONTROL STATION POWER SUPPLY
4	471	W665	ADD: BASE STATION APEXWWM
4	351	DSBA10121	ANTENNA BASE STA OMDIR 144-162MHZ F
300	351	L1705	LDF4-50A CABLE: 1/2" LDF HELIAX POL
8	351	DDN1089	L4TNF-PSA TYPE N FEMALE PS FOR 1/2
4	207	DSIS50NXC2MA	RF SPD, 125-1000MHZ DC BLOCK FLANGE
4	351	DSGKSUNV	GK-SUNV SMALL UNIVERSAL GROUNDING K
40	351	L1700	FSJ1-50A CABLE: 1/4" SUPERFLEX POLY
8	351	DDN9769	F1TNM-HC 1/4" TYPE N MALE CONNECTO
4	351	DSBA10121	ANTENNA BASE STA OMDIR 144-162MHZ F
300	351	L1705	LDF4-50A CABLE: 1/2" LDF HELIAX POL
8	351	DDN1089	L4TNF-PSA TYPE N FEMALE PS FOR 1/2
4	207	DSIS50NXC2MA	RF SPD, 125-1000MHZ DC BLOCK FLANGE
4	351	DSGKSUNV	GK-SUNV SMALL UNIVERSAL GROUNDING K
40	351	L1700	FSJ1-50A CABLE: 1/4" SUPERFLEX POLY
8	351	DDN9769	F1TNM-HC 1/4" TYPE N MALE CONNECTO
13	785	NNTN7065B	IMPRES MULTI UNIT CHARGER US/NA/CA/
80	136	A03JAC9JA1 N	143-174MHz MINITOR VI PAGERS

EXHIBIT B**TERMS**

1. The Equipment is more fully described in Exhibits "A-1" and "A-2" to the Lease Purchase Agreement.
2. Fixed Interest Rate: **1.34%**
Commencement Date: October 31, 2016

Payment Date	Principal Component	Interest Component	Rental Payment
09/01/2017	\$1,096,159.00	\$92,290.40	\$1,188,449.40
03/01/2018	-	47,750.67	47,750.67
09/01/2018	1,148,393.00	47,750.67	1,196,143.67
03/01/2019	-	40,056.44	40,056.44
09/01/2019	1,163,885.00	40,056.44	1,203,941.44
03/01/2020	-	32,258.41	32,258.41
09/01/2020	1,179,587.00	32,258.41	1,211,845.41
03/01/2021	-	24,355.18	24,355.18
09/01/2021	1,195,500.00	24,355.18	1,219,855.18
03/01/2022	-	16,345.33	16,345.33
09/01/2022	1,211,628.00	16,345.33	1,227,973.33
03/01/2023	-	8,227.42	8,227.42
09/01/2023	1,227,973.00	8,227.42	1,236,200.42
Total	\$8,223,125.00	\$430,277.30	\$8,653,402.30

3. The Tower Equipment will be located at the addresses provided on Exhibit A-1, and the Mixed Equipment will be located at or near the Fluvanna County Sheriff's Office, located at 160 Commons Blvd, Palmyra, Virginia 22963, or on the Tower Equipment.
4. Address of Lessee, for notification purposes, is:

132 Main Street	P.O. Box 540
Palmyra, VA 22963	Palmyra, VA 22963
(hand deliveries)	(U.S. Mail)
5. Address of TDEF, for notification purposes, is: 1006 Astoria Boulevard, Cherry Hill, NJ 08034

[Signature Page Follows]

Acknowledged and Accepted:

**LESSEE:
COUNTY OF FLUVANNA, VIRGINIA**

By: 
Name: Steven M. Nichols
Title: County Administrator

[Signature Page to Exhibit B]

EXHIBIT C

INSURANCE COVERAGE REQUIREMENTS CERTIFICATE

1. In accordance with Section 8 of the Lease Purchase Agreement, we have instructed the insurance agent named below (please fill in name, address, contact person, telephone and facsimile numbers).

VaCorp.
 1315 Franklin Road, SW
 Roanoke, Virginia 24016
 Contact: Stephanie Brown
 E-mail: sbrown@riskprograms.com
 Telephone: (844) 986-2705
 Facsimile: (540) 581-0683

to issue:

- a. All Risk Physical Damage Insurance on the leased Equipment (as defined in the Agreement) evidenced by a certificate of Insurance and Long Form Lender Loss Payable Clause naming Lessor "its successors and/or its assigns" as Lender Loss Payee.
- b. Public Coverage Required on non-School bus collateral:
 \$1,000,000.00 per person
 \$1,000,000.00 aggregate bodily injury liability
 \$1,000,000.00 property damage liability
- c. Public Coverage Required on School bus collateral:
 \$5,000,000.00 per person
 \$5,000,000.00 aggregate bodily injury liability
 \$5,000,000.00 property damage liability

OR

2. We are self-insured for all risk physical damage, with the prior written consent of the Lessor, and will provide proof of such self-insurance in letter form together with a copy of the statute authorizing this form of insurance.
3. Proof of insurance coverage as provided in Section 1 or 2 of this Exhibit C will be provided to TDEF prior to the time that the Equipment or Unit thereof is delivered to us.

Certified this 31ST day of October, 2016

**LESSEE:
COUNTY OF FLUVANNA, VIRGINIA**

By: 

Name: Steven M. Nichols

Title: County Administrator

EXHIBIT D

ACCEPTANCE CERTIFICATE

The undersigned, as Lessee under the Lease Purchase Agreement (the "Agreement") numbered 1, with TD EQUIPMENT FINANCE, INC., Lessor, acknowledges receipt in good condition of the Equipment described in Exhibit "A" attached to the Lease Purchase Agreement, a copy of which is attached hereto, this 31st day of October, 2016.

The undersigned officer of Lessee hereby reaffirms in all respects the provisions relating to arbitration contained in the Agreement, and represents that, to the best of his or her knowledge, information and belief, the expectations therein expressed were reasonable as of the date on which they were made, and are reasonable as of this date, and that there were, and are as of this date, no facts, estimates or circumstances other than those expressed therein that would materially affect the expectations expressed therein.

Certified this 31st day of October, 2016

**LESSEE:
COUNTY OF FLUVANNA, VIRGINIA**

By: 

Name: **Steven M. Nichols**

Title: **County Administrator**

EXHIBIT E

[Intentionally Deleted]

EXHIBIT F

CERTIFICATE OF LESSEE

THE UNDERSIGNED, duly authorized representative of the named Lessee under that certain Lease Purchase Agreement dated October 31, 2016 with TD EQUIPMENT FINANCE, INC. as Lessor (the "Agreement") hereby certifies as follows and in accordance with the requirements of the Agreement. Capitalized terms used herein have the same meaning as in the Agreement:

A. INCUMBENCY OF OFFICERS AND SIGNATURES:

I hold the position noted under my signature, and I have all the authority necessary to execute and deliver this Certificate. The following officers of Lessee are duly elected or appointed, and their signatures are true and correct, and where required, have been filed with the appropriate officials of the State:



Signature

Name Printed: Steven M. Nichols
Title Printed: County Administrator

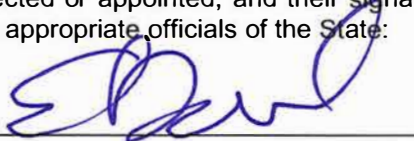

Signature

Name Printed: Eric M. Dahl
Title Printed: Deputy County Administrator/
Director of Finance

B. ESSENTIAL USE:

1. The Equipment will be used by Lessee for the specific purpose of:
2. The Equipment is essential for the functioning of Lessee and is immediately needed by Lessee. Such need is neither temporary nor expected to diminish during the Term hereof. The Equipment is expected to be used by Lessee for a period in excess of the Term hereof.
3. Funds are expected to come from the General Fund of Lessee.

This certificate is based upon facts, circumstances, estimates and expectations of Lessee as of the date on which the Agreement was executed, and to the best of my knowledge and belief, as of this date, such facts, circumstances and estimates are true and correct and such expectations are reasonable.

IN WITNESS WHEREOF, I have executed and delivered this certificate as of the 31 day of October, 2016.

WITNESS:

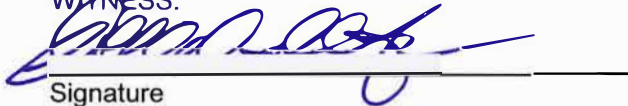
Signature

Richard L. Hurlbert Jr. Bond Counsel
Name & Title Printed

WITNESS:

Signature

MARTIN BROOKHART, MGMT ANALYST
Name & Title Printed

EXHIBIT G-1

[Intentionally Deleted]

EXHIBIT H

[Intentionally Deleted]

EXHIBIT I
GENERAL TERMS

INSURANCE AUTHORIZATION

*****Please be advised that we are unable to release any funds to you or your vendor (s) unless we have a valid Certificate of Insurance. Please contact your agent and have them forward a Certificate to our office immediately. If you have any questions, please call me at 856-685-**

To Whom It May Concern:

This is to advise you that Stephanie Brown Insurance Agent VA Corp Insurance Company

1315 Franklin Rd. SW Roanoke VA 24016
Address City State Zip Code

Stephanie Brown is my authorized agent.

Telephone and Fax Number:

Please contact your agent and ask them to provide a binder or Certificate of Insurance, followed by the original policy, showing the coverage provided, the expiration date, policy number and the equipment covered.

Our insurance requirements are as follows:

- I. **INSURED:**
TD Equipment Finance, Inc., its successors and assigns. ("Lessor")
1006 Astoria Blvd.
Cherry Hill, NJ 08034
Phone: (856) 685-
Fax: (856) -
- II. **LIABILITY INSURANCE:**
Lessor **must** be named as **Additional Insured** as its interests may appear. \$1,000,000 combined single limit for Bodily Injury and Property Damage.
- III. **PHYSICAL DAMAGE INSURANCE:**
Lessor **must** be provided with a standard **Lender's Loss Payable clause** showing the interest of Lessor as lessor and loss payee, and fire and extended coverage, including theft, vandalism, malicious mischief, etc. The insurance is required in amount equal to your equipment cost of or replacement value, whichever is the greater.
- IV. **NOTICE OF CANCELLATION:**
30 Days Notice of Cancellation is required.
- V. **DESCRIPTION OF EQUIPMENT:**
A Description of Equipment Covered **must** be inserted in the Policy and Certificate. Attach a copy of Schedule A, if applicable.

By signing below, we signify that we have contacted our insurance agent and will provide the above coverage and evidence of same will be forwarded to you immediately.

**LESSEE:
COUNTY OF FLUVANNA, VIRGINIA**

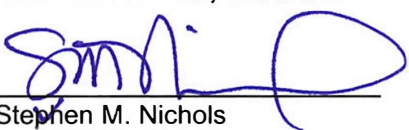
By: 
Name: Stephen M. Nichols
Title: County Administrator

Appendix 1

GENERAL TERMS, CONDITIONS AND INSTRUCTIONS TO BIDDERS AND CONTRACTORS

These General Terms, Conditions and Instructions to Bidders and Contractor (hereinafter referred to as the “General Conditions”) shall apply to all purchases and be incorporated into and be a part of each Solicitation (as defined below) and every Contract (as defined below) awarded by Fluvanna County, a political subdivision of the Commonwealth of Virginia (hereinafter referred to as the “County”) unless otherwise specified by the County in writing. Bidders, Offerors and Contractors or their authorized representatives are expected to inform themselves fully as to these General Conditions before submitting Bids or Proposals to and/or entering into any Contract with the County: failure to do so will be at the Bidder’s/Contractor’s own risk and except as provided by law, relief cannot be secured on the plea of error.

Subject to all Federal, State and local laws, policies, resolutions, regulations, rules, limitations and legislation, including the County’s Procurement Policies and Procedures, Bids or Proposals on all Solicitations issued by County will bind Bidders or Offerors, as applicable, and Contracts will bind Contractors, to all applicable terms, conditions, instructions, rules and requirements herein set forth unless otherwise SPECIFICALLY set forth by the County in writing in the Solicitation or Contract. All provisions of these General Conditions are material to any contract between the County and a Contractor.

INTRODUCTION

1. **VIRGINIA PUBLIC PROCUREMENT ACT AND ETHICS IN PUBLIC CONTRACTING.** The Virginia Public Procurement Act of Virginia Code §§ 2.2-4300 *et seq.* (hereinafter the “VPPA”) is incorporated herein by reference. Nothing in these General Conditions is intended to conflict with the VPPA and in case of any conflict, the VPPA controls. Specifically, the provisions of Article 6 of the VPPA (Virginia Code §§ 2.2-4367 through 2.2-4377) relating to ethics in contracting, shall be applicable to all Solicitations and Contracts solicited or entered into by the County. By submitting their Bids or signing any Contract, all Bidders and Contractors certify that they have not violated any of the provisions of Article 6 of the VPPA, including, but not limited to, that their Bids are made without collusion or fraud and that they have not offered or received any kickbacks or inducements.
2. **DEFINITIONS.** The definitions of Virginia Code §§ 2.2-4301, 2.2-4302.1 and 2.2-4302.2 are specifically incorporated herein by reference and as used in these General Conditions, whether capitalized or not, any of such defined terms have the same meaning as such terms have under the VPPA: such defined terms include: “Affiliate”, “Best Value”, “Business”, “Competitive Negotiation”, “Competitive Sealed Bidding”, “Construction”, “Construction Management Contract”, “Design-Build Contract”, “Employment Services Organization”, “Goods”, “Informality”, “Job Order Contracting”, “Multiphase Professional Services Contract”, “Nonprofessional Services”, “Potential Bidder or Offeror”, “Professional Services”, “Public Body”, “Public Contract”, “Responsible Bidder or Offeror”, “Responsive Bidder”,

“Reverse Auctioning” and “Services”. Additionally, as used in these General Conditions, the following terms, whether capitalized or not, have the following meanings:

- a. Bid/Proposal: The offer of a Bidder or Offeror to provide specific Goods or Services at specified prices and/or other conditions specified in the Solicitation. The term “Bid” is used throughout these General Conditions and where appropriate includes the term “Proposal” or any modifications or amendments to any Bid or Proposal.
- b. Bidder/Offeror/Vendor: Any individual(s), company, firm, corporation, partnership or other organization bidding or offering on any Solicitation issued by the County and/or offering to enter into Contracts with the County. The term “Bidder” is used throughout these General Conditions and where appropriate includes the term “Offeror” and/or “Vendor”.
- c. Contract: Any contract to which the County will be a party.
- d. Contractor: Any individual(s), company, firm, corporation, partnership, or other organization to whom an award is made by the County or whom enters into any contract to which the County is a party.
- e. County: The County of Fluvanna, a political subdivision of the Commonwealth of Virginia, including where applicable all agencies and departments of the County.
- f. County Administrator: The Fluvanna County Administrator.
- g. County Attorney: The Fluvanna County Attorney.
- h. Purchasing Agent: The County Administrator is the County’s Purchasing Agent and is responsible for the purchasing activity of Fluvanna County; and has signatory authority to bind the County to all contracts and purchases made lawfully under the Fluvanna County Small Purchasing Procedures. The Purchasing Agent has signatory authority to bind the County to all other contracts and purchases only after the contracts or purchases have been approved by a vote of the Fluvanna County Board of Supervisors.
- i. General Terms, Conditions and Instructions to Bidders and Contractors (also referred to herein as the “General Conditions”): These General Terms, Conditions and Instructions to Bidders and Contractors shall be attached to and made a part of all Solicitations by the County and all Contracts to which the County is party.
- j. His: Any references to “his” shall include his, her, their, or its as appropriate.
- k. Invitation to Bid (also referred to herein as an “IFB”): A request which is made to prospective Bidders for their quotation on Goods or Services desired by the County. The issuance of an IFB will contain or incorporate by reference the General Conditions and the other specifications and contractual terms and conditions applicable to the procurement.

- l. Purchasing Officer: The Purchasing Officer employed by the County and to whom Bidders/Contractors can submit questions relating to any Bid or Contract.
- m. Request for Proposal (also referred to herein as a “RFP”): A request for an offer from prospective Offerors which shall indicate the general terms which are sought to be procured from Offerors. The RFP will specify the evaluation factors to be used and will contain or incorporate by reference the General Conditions and other applicable contractual terms and conditions, including any unique capabilities or qualifications that will be required of the Contractor.
- n. Small Purchasing Procedures: The County’s Small Purchasing Procedures, being Chapter 4 of the County’s Procurement Policies and Procedures, a method of purchasing not requiring competitive sealed bids or competitive negotiation for single or term contracts for goods and services other than professional services if the aggregate or the sum of all phases is not expected to exceed \$50,000; and also allowing for single or term contracts for professional services without requiring competitive negotiation, provided the aggregate or the sum of all phases is not expected to exceed \$50,000.
- o. Solicitation: The process of notifying prospective Bidders or Offerors that the County wishes to receive Bids or Proposals on a set of requirements to provide Goods or Services. “Solicitation” includes any notification of the County requirements may consist of public advertising (newspaper, County’s website, or other electronic notification), the mailing of notices of Solicitation, any Invitation for Quotes (“IFQ”), Initiations to Bid (“IFB”), or Requests for Proposal (“RFP”), the public posting of notices, issuance of an Open Market Procurement (“OMP”), or telephone calls to prospective Bidders or Offerors.
- p. State: The Commonwealth of Virginia.

3. AUTHORITY

- a. The Purchasing Agent shall serve as the principal public purchasing official for the County, and shall be responsible for the procurement of goods, services, insurance and construction in accordance with the County’s Procurement Policies and Procedures. The Purchasing Agent has responsibility and authority for negotiating, placing and when necessary modifying every Solicitation, Contract and purchase order issued by the County under the County’s Small Purchasing Procedures. The Purchasing Agent has signatory authority to bind the County to all contracts and purchases made lawfully under the County’s Small Purchasing Procedures. The Purchasing Agent has responsibility and authority for negotiating, placing and when necessary modifying every other Solicitation, Contract and purchase order issued by the County except that the Purchasing Agent has signatory authority to bind the County to all other contracts and purchases ONLY after the contracts or purchases have been adopted and approved by a vote of the Fluvanna County Board of Supervisors (the “Board”).
- b. Unless specifically delegated by the Board or the Purchasing Agent, and consistent with the limited authority granted thereto, no other County officer or employee is authorized to

order supplies or Services, enter into purchase negotiations or Contracts, or in any way obligate the County for any indebtedness. Any purchase or contract made which is contrary to such authority shall be of no effect and void and the County shall not be bound thereby.

- c. For convenience, the County's Purchasing Officer shall serve as an intermediary between the Purchasing Agent and the Bidder or Contractor and any Bidder or Contractor may direct communications regarding any purchase, Solicitation or Contract to the Purchasing Officer; however as stated supra only the Board or County's Purchasing Agent can bind the County and only upon the conditions stated supra.

CONDITIONS OF BIDDING

4. **COMPETITION INTENDED.** It is the County's intent to encourage and permit open and competitive bidding in all Solicitations. It shall be the Bidder's responsibility to advise the County in writing if any language, requirement, specification, etc., or any combination thereof, stifles competition or inadvertently restricts or limits the requirements stated in a Solicitation to a single source. The County must receive such notification not later than seven (7) business days prior to the deadline set for acceptance of the Bids. In submitting a Bid, the Bidder guarantees that he or she has not been a party with other Bidders to an agreement to bid a fixed or uniform price. Violation of this implied guarantee shall render the Bid of any Bidder involved void.
5. **DISCRIMINATION PROHIBITED.** Pursuant to Virginia Code § 2.2-4310, the County does not discriminate against Bidders, Offerors or Contractors because of race, religion, color, sex, national origin, age, disability, status as a service disabled veteran, or any other basis prohibited by state law relating to discrimination in employment. Whenever solicitations are made, the County shall include businesses selected from a list made available by the Department of Small Business and Supplier Diversity. Pursuant to Virginia Code § 2.2-4343.1, the County does not discriminate against "faith-based organizations", being a religious organization that is or applies to be a contractor to provide goods or services for programs funded by the block grant provided pursuant to the Personal Responsibility and Work Reconciliation Act of 1996, P.L. 104-193.
6. **CLARIFICATION OF TERMS.** Pursuant to Virginia Code § 2.2-4316, if any Bidder has questions or comments about the specifications or other Solicitation documents, the prospective Bidder should contact the County no later than seven (7) business days prior to the date set for the opening of Bids or receipt of Proposals. Any revisions to the Solicitation will be made only by written addendum issued by the County. Notifications regarding specifications may not be considered if received in less than seven (7) business days of the date set for opening of Bids/receipt of Proposals.
7. **MANDATORY USE OF COUNTY FORM AND TERMS AND CONDITIONS.** Unless otherwise specified in the Solicitation, all Bids must be submitted on the forms provided by the County, including but not limited to, a Cover Sheet or Pricing Schedule, if applicable, properly signed in ink in the proper spaces and submitted in a sealed envelope or package. Unauthorized modification of or additions to any portion of the Solicitation may be cause for

rejection of the Bid. However, the County reserves the right to decide, on a case by case basis, in its sole discretion, whether to reject any Bid or Proposal which has been modified. These General Conditions are mandatory provisions of all Solicitations and all Contracts of the County.

8. **LATE BIDS & MODIFICATION OF BIDS.** Any Bid or modification thereto received at the office designated in the Solicitation after the exact time specified for receipt of the Bid is considered a late Bid or modification thereof. The County is not responsible for delays in the delivery of the mail by the U.S. Postal Service, private carriers or the inter-office mail system. It is the sole responsibility of the Bidder to ensure their Bid reaches County by the designated date and hour. The following rules apply to all Bids submitted to the County:
- a. The official time used in the receipt of Bids/Proposals is that time on the automatic time stamp machine in the Finance Department;
 - b. Late Bids or modifications thereof will be returned to the Bidder UNOPENED, if Solicitation number, due date and Bidder's return address is shown on the container;
 - c. If a Bid is submitted on time, however a modification thereto is submitted after the due date and time, then the County in its sole discretion may choose to consider the original Bid except that the County may not consider such original Bid if the Bid is withdrawn by the Bidder pursuant to Section 9 below; and
 - d. If an emergency or unanticipated event or closing interrupts or suspends the County's normal business operations so that Bids cannot be received by the exact time specified in the Solicitation, then the due date/time specified for receipt of Bids will be deemed to be extended to the same time of day specified in the Solicitation on the first work day on which normal County business operations resume.
9. **WITHDRAWAL OF BIDS**
- a. Pursuant to Virginia Code § 2.2-4330, a Bidder for a public construction contract, other than a contract for construction or maintenance of public highways, may withdraw his Bid from consideration if the price bid was substantially lower than the other Bids due solely to a mistake in the Bid, provided the Bid was submitted in good faith, and the mistake was a clerical mistake as opposed to a judgment mistake, and was actually due to an unintentional arithmetic error or an unintentional omission of a quantity of work, labor or material made directly in the compilation of a Bid, which unintentional arithmetic error or unintentional omission can be clearly shown by objective evidence drawn from inspection of original work papers, documents and materials used in the preparation of the Bid sought to be withdrawn.

If a Bid contains both clerical and judgment mistakes, a Bidder may withdraw his Bid from consideration if the price bid would have been substantially lower than the other Bids due solely to the clerical mistake, that was an unintentional arithmetic error or an unintentional omission of a quantity of work, labor or material made directly in the compilation of a Bid

that shall be clearly shown by objective evidence drawn from inspection of original work papers, documents and materials used in the preparation of the Bid sought to be withdrawn. The Bidder shall give notice in writing to the County of his or her claim of right to withdraw his or her Bid within two (2) business days after the conclusion of the Bid opening procedure and shall submit original work papers with such notice.

- b. A Bidder for a Contract other than for public construction may request withdrawal of his or her Bid under the following circumstances:
 - (1) Bids may be withdrawn on written request from the Bidder received at the address shown in the Solicitation prior to the time of opening.
 - (2) Requests for withdrawal of Bids after opening of such Bids but prior to award shall be transmitted to the County, in writing, accompanied by full documentation supporting the request. If the request is based on a claim of error, documentation must show the basis of the error. Such documentation may take the form of supplier quotations, Bidder work sheets, etc. If Bid bonds were tendered with the Bid, the County may exercise its right of collection.
 - c. No Bid may be withdrawn under this Section 9 when the result would be the awarding of the Contract on another Bid of the same Bidder or of another Bidder in which the ownership of the withdrawing Bidder is more than five percent (5%).
 - d. If a Bid is withdrawn under the authority of this Section 9 the lowest remaining Bid shall be deemed to be the low Bid.
 - e. No Bidder who, is permitted to withdraw a Bid shall, for compensation, supply any material or labor to or perform any subcontract or other work agreement for the person or firm to whom the Contract is awarded or otherwise benefit, directly or indirectly, from the performance of the project for which the withdrawn Bid was submitted.
 - f. The County shall notify the Bidder in writing within five (5) business days of its decision regarding the Bidder's request to withdraw its Bid. If the County denies the withdrawal of a Bid under the provisions of this Section 9, it shall State in such notice the reasons for its decision and award the Contract to such Bidder at the Bid price, provided such Bidder is a responsible and responsive Bidder. At the same time that the notice is provided, the County shall return all work papers and copies thereof that have been submitted by the Bidder.
 - g. Under these procedures, a mistake shall be proved only from the original work papers, documents and materials delivered as required herein. The work papers, documents and materials submitted by the bidder shall, at the bidder's request, be considered trade secrets or proprietary information subject to the conditions of subsection F of Virginia Code § 2.2-4342.
10. **ERRORS IN BIDS.** When an error is made in extending total prices, the unit Bid price will govern. Erasures in Bids must be initialed by the Bidder. Carelessness in quoting prices, or

otherwise in preparation of the Bid, will not relieve the Bidder. Bidders/Offerors are cautioned to recheck their Bids for possible error. Errors discovered after public opening cannot be corrected and the Bidder will be required to perform if his or her Bid is accepted.

11. **IDENTIFICATION ON BID ENVELOPE.** All Bids, Proposals and requested copies thereof submitted to the County shall be in a separate envelope or package, sealed and identified with the following information clearly marked on the outside of the envelope or package:

- a. Addressed as indicated on page 1 of the solicitation;
- b. Solicitation number;
- c. Title;
- d. Bid due date and time;
- e. Bidder's name and complete mailing address (return address); and
- f. Pursuant to Virginia Code § 2.2-4311.2, the Bidder's identification number issued by the State Corporation Commission, or if the bidder is not required to be authorized to transact business in the Commonwealth as a foreign business entity under Title 13.1 or Title 50 or as otherwise required by law shall include in its bids or proposal a statement describing why the bidder or offeror is not required to be so authorized.

If a Bid is not addressed with the information as shown above, the Bidder takes the risk that the envelope may be inadvertently opened and the information compromised, which may cause the Bid to be disqualified. Bids may be hand delivered to the designated location in the County's offices. No other correspondence or other Proposals/Bids should be placed in the envelope. Any Bidder or Offeror that fails to provide the information required in (f) above shall not receive an award unless a waiver is specifically granted by the County Administrator.

12. **ACCEPTANCE OF BIDS.** Unless otherwise specified, all formal Bids or Proposals submitted shall be valid for a minimum period of one hundred twenty (120) calendar days following the date established for opening or receipt, respectively, unless extend by mutual agreement of the parties. At the end of the one hundred twenty (120) calendar days the Bid/Proposal may be withdrawn at the written request of the Bidder. Thereafter, unless and until the Proposal is withdrawn, it remains in effect until an award is made or the Solicitation is canceled by the County. The County may cancel any Solicitation at any time by notice of such cancelation to the Bidders.

13. **COMPLETENESS.** To be responsive, a Bid must include all information required by the Solicitation.

14. **CONDITIONAL BIDS.** Conditional Bids are subject to rejection in whole or in part.

15. **RESPONSE TO SOLICITATIONS.** In the event a Bidder cannot submit a Bid on a Solicitation, the Bidder is requested to return the Solicitation cover sheet with an explanation as to why the Bidder is unable to Bid on these requirements, or if there be no cover sheet for the Solicitation a letter to the County explaining the same.
16. **BIDDER INTERESTED IN MORE THAN ONE BID AND COLLUSION.** More than one bid from an individual, firm, partnership, corporation or association under the same or different name will be rejected. Reasonable grounds for believing that a bidder is interested in more than one bid for the work contemplated will cause rejection of all bids in which the bidder is interested. Any or all bids may be rejected if there is any reason for believing that collusion exists among the bidders. Participants in such collusion may not be considered in future bids for the same work. Each bidder, as a condition of submitting a bid, shall certify that he is not a party to any collusive action as herein defined. However, a party who has quoted prices on work, materials, or supplies to a Bidder is not thereby disqualified from quoting prices to other Bidders or firms submitting a Bid directly for the work, materials or supplies.
17. **BID OPENING.** Pursuant to Virginia Code § 2.2-4301, all Bids received in response to an IFB will be opened at the date, time and place specified, and announced publicly, and made available for inspection as provided in Section 21 of these General Conditions. Proposals received in response to an RFP will be made available for inspection as provided in Section 21 of these General Conditions.
18. **TAX EXEMPTION.** The County is exempt from the payment of any federal excise or any Virginia sales tax. The price bid must be net, exclusive of taxes. Tax exemption certificates will be furnished if requested by the Bidder.
19. **DEBARMENT STATUS.** By submitting their Bids, Bidders certify that they are not currently debarred from submitting Bids on Contracts by the County, nor are they an agent of any person or entity that is currently debarred from submitting Bids or Proposals on Contracts by the County or any agency, public entity/locality or authority of the State.
20. **NO CONTACT POLICY.** No Bidder shall initiate or otherwise have contact related to the Solicitation with any County representative or employee, other than the Purchasing Officer or Purchasing Agent, after the date and time established for receipt of Bids. Any contact initiated by a Bidder with any County representative, other than the Purchasing Officer or Purchasing Agent, concerning this Solicitation is prohibited and may cause the disqualification of the Bidder.
21. **VIRGINIA FREEDOM OF INFORMATION ACT.** As provided under Virginia Code § 2.2-4342, all proceedings, records, Contracts and other public records relating to procurement transactions shall be open to the inspection of any citizen, or any interested person, firm or corporation, in accordance with the Virginia Freedom of Information Act of Virginia Code §§ 2.2-3700 *et seq.*, except:

- a. Cost estimates relating to a proposed procurement transaction prepared by or for the County shall not be open to public inspection;
 - b. Any competitive sealed bidding Bidder, upon request, shall be afforded the opportunity to inspect Bid records within a reasonable time after the opening of Bids but prior to award, except in the event that the County decides not to accept any of the Bids and to reopen the Contract. Otherwise, Bid records shall be open to public inspection only after award of the Contract;
 - c. Any competitive negotiation Offeror, upon request, shall be afforded the opportunity to inspect Proposal records within a reasonable time after the evaluation and negotiations of Proposals are completed but prior to award except in the event that the County decides not to accept any of the Proposals and to reopen the Contract. Otherwise, Proposal records shall be open to the public inspection only after award of the Contract;
 - d. Any inspection of procurement transaction records under this Section 21 shall be subject to reasonable restrictions to ensure the security and integrity of the records;
 - e. Trade secrets or proprietary information submitted by a Bidder, Offeror or Contractor in connection with a procurement transaction shall not be subject to public disclosure under the Virginia Freedom of Information Act; however, the Bidder, Offeror or Contractor must invoke the protections of this Section 21 prior to or upon submission of the data or other materials, and must identify the data or other materials to be protected and State the reasons why protection is necessary; and
 - f. Nothing contained in this Section 21 shall be construed to require the County, when procuring by “competitive negotiation” (RFP), to furnish a Statement of reasons why a particular Proposal was not deemed to be the most advantageous to the County.
22. **CONFLICT OF INTEREST.** Bidder/Contractor certifies by signing any Bid/Contract to/with the County that no conflict of interest exists between Bidder/Contractor and County that interferes with fair competition and no conflict of interest exists between Bidder/Contractor and any other person or organization that constitutes a conflict of interest with respect to the Bid/Contract with the County.

SPECIFICATIONS

23. **OMISSIONS OR DISCREPANCIES.** Any items or parts of any equipment listed in a Solicitation which are not fully described or are omitted from such specification, and which are clearly necessary for the completion of such equipment and its appurtenances, shall be considered a part of such equipment although not directly specified or called for in the specifications. Should a Bidder find a discrepancy or ambiguity in, or an omission from, the Solicitation, including the drawings and/or specifications, he or she shall so notify the County within twenty-four (24) hours of noting the discrepancy, ambiguity or omission and in any event no less than five (5) days prior to the date set for the opening of Bids. If necessary, the County will send a written addendum for clarification to all Bidders no later than three (3) days

before the date set for opening of Bids. Any notification regarding specifications received less than five (5) days prior to the date set for the opening of Bids may or may not be considered by the County in its sole discretion. The Bidder shall abide by and comply with the true intent of the specifications and not take advantage of any unintentional error or omission, but shall fully complete every part as the true intent and meaning of the specifications and drawings. Whenever the mention is made of any articles, material or workmanship to be in accordance with laws, ordinances, building codes, underwriter's codes, A.S.T.M. regulations or similar expressions, the requirements of these laws, ordinances, etc., shall be construed as to the minimum requirements of these specifications.

24. **BRAND NAME OR EQUAL ITEMS.** Pursuant to Virginia Code § 2.2-4315, unless otherwise provided in the Solicitation, the name of a certain brand, make or manufacturer does not restrict Bidders to the specific brand, make or manufacturer named; it conveys the general style, type, character, and quality of the article desired, and any article which the County in its sole discretion determines to be the equal of that specified, considering quality, workmanship, economy of operation, and suitability for the purpose intended, shall be accepted. The Bidder is responsible to clearly and specifically indicate the product being offered and to provide sufficient descriptive literature, catalog cuts and technical detail to enable the County to determine if the product offered meets the requirements of the Solicitation. This is required even if offering the exact brand, make or manufacturer specified. Normally in competitive sealed bidding, only the information furnished with the Bid will be considered in the evaluation. Failure to furnish adequate data for evaluation purposes may result in declaring a Bid non-responsive. Unless the Bidder clearly indicates in its Bid that the product offered is "equal" product, such Bid will be considered to offer the brand name product referenced in the Solicitation.
25. **FORMAL SPECIFICATIONS.** When a Solicitation contains a specification which states no substitutes, no deviation therefrom will be permitted and the Bidder will be required to furnish articles in conformity with that specification.
26. **CONDITION OF ITEMS.** Unless otherwise specified in the Solicitation, all items shall be new, in first class condition.

AWARD

27. **RESPONSIBLE BIDDERS.** In determining whether a Bidder is a responsible Bidder as defined herein, at minimum, the following criteria will be considered.
- a. The ability, capacity and skill of the Bidder to perform the Contract or provide the service required under the Solicitation;
 - b. Whether the Bidder can perform the Contract or provide the service promptly, or within the time specified, without delay or interference;
 - c. The character, integrity, reputation, judgment, experience and efficiency of the Bidder;

- d. The quality of performance of previous Contracts or Services;
- e. The previous and existing compliance by the Bidder with laws and ordinances relating to the Contract or Services;
- f. The sufficiency of the financial resources and ability of the Bidder to perform the Contract or provide the service;
- g. The quality, availability and adaptability of the Goods or Services to the particular use required;
- h. The ability of the Bidder to provide future maintenance and service for the use of the subject of the Contract;
- i. The number and scope of the conditions attached to the Bid;
- j. Whether the Bidder is in arrears to the County on debt or Contract or is a defaulter on surety to the County or whether the Bidder's County taxes or assessments are delinquent; and
- k. Such other information as may be secured by the County, the Purchasing Agent or the Purchasing Officer having a bearing on the decision to award the Contract. If an apparent low Bidder is not awarded a Contract for reasons of nonresponsibility, the County shall so notify that Bidder and shall have recorded the reasons in the Solicitation or Contract file.

28. **AWARD OR REJECTION OF BIDS; WAIVER OF INFORMALITIES.** The County shall award the Contract to the lowest responsive and responsible Bidder complying with all provisions of the IFB, provided the Bid price is reasonable and it is in the best interest of the County to accept it. Awards made in response to a RFP will be made to the highest qualified Offeror whose Proposal is determined, in writing, to be the most advantageous to the County taking into consideration the evaluation factors set forth in the RFP. The County reserves the right to award a Contract by individual items, in the aggregate, or in combination thereof, or to reject any or all Bids and to waive any informality in Bids received whenever such rejection or waiver is in the best interest of the County. Award may be made to as many Bidders/Offerors as deemed necessary to fulfill the anticipated requirements of the County. The County also reserves the right to reject the Bid if a Bidder is deemed to be a non-responsible Bidder. Pursuant to Virginia Code § 2.2-4319, an IFB, a RFP, any other solicitation, or any and all bids or proposals, may be canceled or rejected by the County at any time. The reasons for cancellation or rejection shall be made part of the contract file. The County shall not cancel or reject an IFB, a RFP, any other solicitation, bid or proposal solely to avoid awarding a contract to a particular responsive and responsible bidder or offeror.
29. **EXCLUSION OF INSURANCE BIDS PROHIBITED.** Pursuant to Virginia Code § 2.2-4320, notwithstanding any other provision of law or these General Conditions, no insurer licensed to transact the business of insurance in the State or approved to issue surplus lines insurance in the State shall be excluded from presenting an insurance bid proposal to the

County in response to a RFP or an IFB; excepting that the County may debar a prospective insurer pursuant to its Debarment Policy, see Chapter 2 of the County's Procurement Policies and Procedures.

30. **ANNOUNCEMENT OF AWARD.** Upon the award or announcement of the decision to award a Contract as a result of this Solicitation, the County will publicly post such notice on the County's bulletin board located at 72 Main Street, 2nd Floor, Palmyra, Virginia 22963. Award results may also be viewed on the County's website.
31. **QUALIFICATIONS OF BIDDERS OR OFFERORS.** The County may make such reasonable investigations as deemed proper and necessary to determine the ability of the Bidder to perform the work/furnish the item(s) and the Bidder shall furnish to the County all such information and data for this purpose as may be requested. The County reserves the right to inspect Bidder's physical facilities prior to award to satisfy questions regarding the Bidder's capabilities. The County further reserves the right to reject any Bid or Proposal if the evidence submitted by or investigations of, such Bidder fails to satisfy the County that such Bidder is properly qualified to carry out the obligations of the Contract and to complete the work/furnish the item(s) contemplated therein.
32. **TIE BIDS AND PREFERENCE FOR VIRGINIA PRODUCTS WITH RECYCLED CONTENT AND FOR VIRGINIA FIRMS**
 - a. Pursuant to Virginia Code § 2.2-4328, in the case of a tie bid on an IFB only, the County may give preference to Goods, Services and construction produced in Fluvanna County or provided by persons, firms or corporations having principal places of business in Fluvanna County. If such choice is not available, preference shall then be given to Goods produced in Virginia, or for goods, services or construction provided by Virginia persons, firms, corporations, pursuant Virginia Code § 2.2-4324. If no County or State choice is available, the tie shall be decided publicly by lot. The decision by the County to make award to one or more such Bidders shall be final.
 - b. Whenever the lowest responsive and responsible bidder is a resident of any other state and such state under its laws allows a resident contractor of that state a percentage preference, a like preference shall be allowed to the lowest responsive and responsible bidder who is a resident of Virginia and is the next lowest bidder. If the lowest responsive and responsible bidder is a resident of any other state and such state under its laws allows a resident contractor of that state a price-matching preference, a like preference shall be allowed to responsive and responsible bidders who are residents of Virginia. If the lowest bidder is a resident contractor of a state with an absolute preference, the bid shall not be considered. The Department of General Services shall post and maintain an updated list on its website of all states with an absolute preference for their resident contractors and those states that allow their resident contractors a percentage preference, including the respective percentage amounts. For purposes of compliance with this Section 32, the County may rely upon the accuracy of the information posted on this website.

- c. Notwithstanding the provisions of subsections a and b, in the case of a tie bid in instances where goods are being offered, and existing price preferences have already been taken into account, preference shall be given to the bidder whose goods contain the greatest amount of recycled content.
- d. For the purposes of this Section 32, a Virginia person, firm or corporation shall be deemed to be a resident of Virginia if such person, firm or corporation has been organized pursuant to Virginia law or maintains a principal place of business within Virginia.

33. **NEGOTIATION WITH LOWEST RESPONSIBLE BIDDER.** Pursuant to Virginia Code § 2.2-4318, unless cancelled or rejected, a responsive Bid from the lowest responsible Bidder shall be accepted as submitted, except that if the Bid from the lowest responsible Bidder exceeds available funds, the County may negotiate with the apparent low Bidder to obtain a Contract price within available funds. However, the negotiation may be undertaken only under conditions and procedures described in writing and approved by the County prior to issuance of the IFB and summarized therein.

CONTRACT PROVISIONS

34. **APPLICABLE LAW AND COURTS.** Any Bid or Contract resulting from a Solicitation and its terms, including, but not limited to, the parties' obligations under it, and the remedies available to each party for breach of it, shall be governed by, construed and interpreted in accordance with the laws of the Commonwealth of Virginia, and exclusive jurisdiction and venue of any dispute or matters involving litigation between the parties hereto shall be in the courts of Fluvanna County, Virginia. Any jurisdiction's choice of law, conflict of laws, rules, or provisions, including those of the Commonwealth of Virginia, that would cause the application of any laws other than those of the Commonwealth of Virginia, shall not apply. The Contractor shall comply with applicable federal, State and local laws, ordinances, rules and regulations in performance of the Contract.
35. **PROVISION AND OWNERSHIP OF INFORMATION.** The County shall make a good faith effort to identify and make available to the Contractor all non-confidential technical and administrative data in the County's possession which the County may lawfully release including, but not limited to Contract specifications, drawings, correspondence, and other information specified and required by the Contractor and relating to its work under any Contract. The County reserves its rights of ownership to all material given to the Contractor by the County and to all background information documents, and computer software and documentation developed by the Contractor in performing any Contract.
36. **DOCUMENTS.** All documents, including but not limited to data compilations, drawings, reports and other material, whether in hard copy or electronic format, prepared, developed or furnished by the Contractor pursuant to any Contract shall be the sole property of the County. At the direction of the County, the Contractor shall have the right to make copies of the documents produced available to other parties. The County shall be entitled to delivery of possession of all documents, upon payment in accordance with the terms of any Contract for the service incurred to produce such documents.

- 37. **CONFIDENTIALITY.** Contractor shall not publish, copyright or otherwise disclose or permit to be disclosed or published, the results of any work performed pursuant to this contract, or any particulars thereof, including forms or other materials developed for the County in connection with the performance by Contractor of its services hereunder, without prior written approval of the County. Contractor, cognizant of the sensitive nature of much of the data supplied by the County, shall not disclose any information (other than information which is readily available from sources available to the general public) obtained by it in the course of providing services hereunder without the prior written approval of the County, unless disclosure of such information by it is required by law, rule or regulation or the valid order of a court or administrative agency.

- 38. **INDEPENDENT CONTRACTOR.** The Contractor and any agents, or employees of the Contractor, in the performance of any Contract shall act as an independent contractor and not as officers, employees or agents of the County.

- 39. **INSURANCE.** The Contractor agrees that, during the period of time it renders services to the County pursuant to any Contract, it shall carry (and provide the County with evidence of coverage) the following minimum amounts of insurance.

Automobile	\$500,000	Liability Medical Payment Comprehensive Collision
Public Liability	\$1,000,000	
Professional Liability	\$1,000,000	
Excess Liability	\$2,000,000	Aggregate Over Above Policy Limits (Excluding Professional Liability)
Worker's Compensation	Amount required by Virginia law	

The Contract may specifically require the Contractor to carry higher minimum amounts of insurance.

In addition, the Contractor shall require, and shall include in every subcontract, that any subcontractor providing any goods or services related to such Contract obtain, and continue to maintain for the duration of the work, workers' compensation coverage in the amount required by Virginia law.

- 40. **KEY PERSONNEL.** For the duration of any Contract, the Contractor shall make no substitutions of key personnel unless the substitution is necessitated by illness, death, or termination of employment, or as expressly approved by the County. The Contractor shall

notify the County within five (5) calendar days after the occurrence of any of these events and provide the information required by the paragraph below.

The Contractor shall provide a detailed explanation of the circumstances necessitating any proposed substitution, complete resumes for the proposed substitute, and any additional information requested by the County. The proposed substitute should have comparable qualifications to those of the person being replaced. The County will notify the Contractor within fifteen (15) calendar days after receipt of all required information of its approval or disapproval of the proposed substitution.

41. **SEVERABILITY**. If any term, covenant or provision of these General Conditions or any Contract shall be held to be invalid, illegal or unenforceable in any respect, these General Conditions and any Contract shall remain in effect and be construed without regard to such provision.
42. **TITLES**. The titles and section headings herein and in any Contract are inserted solely for convenience and are not to be construed as a limitation on the scope of the provisions to which they refer.
43. **ATTORNEYS' FEES**. In the event of a dispute between the County and Contractor under any Contract which cannot be amicably resolved, in addition to all other remedies, the party substantially prevailing in any litigation shall be entitled to recover its reasonable expenses, including, but not limited to, reasonable attorneys' fees.
44. **NO WAIVER**. Neither any payment for, nor acceptance of, the whole or any part of the services by the County, nor any extension of time, shall operate as a waiver of any provision of any Contract, nor of any power herein reserved to the County, or any right to damages herein provided, nor shall any waiver of any breach of any Contract be held to be a waiver of any other or subsequent breach. Failure of the County to require compliance with any term or condition of any Contract shall not be deemed a waiver of such term or condition or a waiver of the subsequent enforcement thereof.
45. **NO FINANCE CHARGES**. No finance charges shall be paid by the County.
46. **ANTITRUST**. By entering into a Contract, the Contractor conveys, sells, assigns, and transfers to the County all rights, title and interest in and to all causes of the action it may now have or hereafter acquire under the antitrust law of the United States or the State, relating to the particular Goods or Services purchased or acquired by the County under said Contract. Consistent and continued tie bidding could cause rejection of Bids by the County and/or investigation for antitrust violations.
47. **PAYMENT**. Pursuant to Virginia Code § 2.2-4352, unless more time is provided in the Solicitation or Contract, payment will be made forty-five (45) days after receipt by the County of a proper invoice, or forty-five (45) days after receipt of all Goods or acceptance of work, whichever is later. The County reserves the right to withhold any or all payments or portions thereof for Contractor's failure to perform in accordance with the provision of the Contract or

any modifications thereto. Within twenty (20) days of receipt of proper invoice or of goods or services, the County shall notify the Contractor if any defect or impropriety that would prevent payment by the payment date. The following provisions apply to such payments.

- a. Invoices for items/Services ordered, delivered/performed and accepted shall be submitted by the Contractor in duplicate directly to the payment address shown on the purchase order, Solicitation or Contract, as applicable. All invoices shall show the Contract number, purchase order number, or Solicitation number, as applicable, and as required under Virginia Code § 2.2-4354, either the individual Contractor's social security number or the Contractor's federal employer identification number, whichever is applicable.
- b. Any payment terms requiring payment in less than forty-five (45) days will be regarded as requiring payment forty-five (45) days after receipt of proper invoice or receipt of all Goods or acceptance of work, whichever occurs later. Notwithstanding the foregoing, offers of discounts for payment in less than forty-five (45) days are valid and enforceable.
- c. Pursuant to Virginia Code § 2.2-4353, the date any payment shall be deemed the date of postmark in all cases where payment is made by mail.
- d. The County's fiscal year is July 1 to June 30. Contractors are advised to submit invoices, especially for Goods and/or Services provided in the month of June, for the entire month (i.e. June 1 - June 30), so that expenses are recognized in the appropriate fiscal year.
- e. Any payment made by the Contractor to the County shall only be made in U.S. Dollars. If payment is received in foreign currency the County may, in its sole discretion, reject such payment and require immediate compensation in U.S. Dollars.

48. **SUBCONTRACTORS.** Pursuant to Virginia Code § 2.2-4354, in the event that any subcontractors are used by Contractor in connection with the work, Contractor shall.

- a. Within seven (7) days after receipt of amounts paid to the Contractor for work performed by a subcontractor, either.
 - i. Pay the subcontractor for the proportionate share of the total payment received attributable to the work performed by the subcontractor under any Contract; or
 - ii. Notify the County and subcontractor, in writing, of his intention to withhold all or a part of the subcontractor's payment with the reason for nonpayment.
- b. Contractor shall require each subcontractor to provide either (i) for an individual, their social security numbers, or (ii) for proprietorships, partnerships, and corporations to provide their federal employer identification numbers.
- c. The Contractor shall pay interest to any subcontractor on all amounts owed by the Contractor that remain unpaid after seven days following receipt by the Contractor of payment from the County for work performed by the subcontractor under any Contract,

except for amounts withheld as allowed in subdivision (a)(II) above. Unless otherwise provided under the terms of any Contract, interest shall accrue at the rate of one percent (1%) per month.

- d. The Contractor shall include in each of its subcontracts under any Contract a provision requiring each subcontractor to include or otherwise be subject to the above payment and interest requirements (a), (b) and (c) with respect to each lower tier subcontractor.
- e. The Contractor's obligation to pay an interest charge to a subcontractor pursuant to the payment clause in this Section 48 shall not be construed to be an obligation of the County. No Contract modification may be made for the purpose of providing reimbursement for such interest charge. No cost reimbursement claim may include any amount for reimbursement for such interest charge.

49. RETAINAGE ON CONSTRUCTION CONTRACTS. Pursuant to Virginia Code 2§ 2.2-4333, if a Contract for construction provides for progress payments in installments based upon an estimated percentage of completion, then the contractor shall be paid at least ninety-five percent (95%) of the earned sum when payment is due, with no more than five percent (5%) being retained to ensure faithful performance of the contract. All amounts withheld may be included in the final payment. Any subcontract related to work on a Contract that provides for similar progress payments shall be subject to the provisions above and the Contractor agrees to include such provisions in every subcontract.

50. SUCCESSORS AND ASSIGNS. The County and the Contractor bind themselves and their respective successors and assigns to any Contract. The foregoing notwithstanding, the Contractor shall not assign, sublet or transfer its interest in any Contract without the prior written consent of the County, which may be granted or withheld in the County's sole discretion. Nothing hereinafter mentioned shall be construed as creating any personal liability on the part of any officer, agent or employee of the County, nor shall it be construed as giving any benefits hereunder to anyone other than the County and the Contractor.

51. DEFAULT. Failure of a Contractor to deliver Goods or Services in accordance with Contract terms and conditions and/or within the time specified, or within reasonable time as interpreted by the County in its sole discretion, or failure to make replacements/corrections of rejected articles/services when so requested, immediately or as directed by the County, or failure of the Contractor to act in accordance with the Contract in any material respect, as reasonably determined by the County, shall constitute a "default" by the Contractor and shall further authority for the County to purchase in the open market articles/services of comparable grade/quality to replace the services, articles rejected, and/or not delivered. On all such purchases, the Contractor shall reimburse the County, within a reasonable time specified by the County, for any expense incurred in excess of Contract prices including, but not limited to, any purchase and administrative costs. Such purchases shall be deducted from the Contract quantities, if applicable. Should public necessity demand it, the County reserves the right to use or consume articles delivered or services performed which are substandard in quality, subject to an adjustment in price to be determined by the County. In case of any default, the County, after due oral or written notice if required in accordance with the Contract, may

terminate the Contract at its option in its sole discretion effective immediately. These remedies shall be in addition to any other remedies which the County may have, including but not limited to, any remedies at law, under the Contract or in equity.

Notwithstanding the foregoing, the Contractor shall not be liable for damages for delay in shipment or failure to deliver when such delay or failure is the result of fire, flood, strike, act of God, act of Government, act of an alien enemy or by any other circumstances which, in the County's opinion, are beyond the control of the Contractor. Under such circumstances, however, the County may, at its sole discretion, terminate or cancel the Contract effective immediately.

52. **NON-DISCRIMINATION ASSURANCES.** The Contractor shall conform to the provisions of the Federal Civil Rights Act of 1964, as amended, as well as the Virginia Fair Employment Act of 1975, as amended, where applicable, and § 2.2-4311 of the Virginia Procurement Act.

- a. During the performance of any Contract, the Contractor agrees as follows. the Contractor will not discriminate against any employee or applicant for employment because of race, religion, color, sex, national origin, age, disability, or other basis prohibited by state law relating to discrimination in employment, except where there is a bona fide occupational qualification reasonably necessary to the normal operation of the Contractor. The Contractor agrees to post in conspicuous places, available to employees and applicants for employment, notices setting forth the provisions of this nondiscrimination clause. The Contractor, in all Solicitations or advertisements for employees placed by or on behalf of the Contractor, will state that such Contractor is an equal opportunity employer. Notices, advertisements and Solicitations placed in accordance with federal law, rule or regulation shall be deemed sufficient for the purpose of meeting the requirements of this Section 52.
- b. The Contractor shall include the provisions of paragraph (a) above in every subcontract or purchase over \$10,000.00 so that the provisions will be binding upon each subcontractor or Vendor.

53. **MODIFICATION**

- a. Pursuant to Virginia Code § 2.2-4309, these General Conditions and any Contract entered into by the County and any Contractor shall not be subject to change, modification, or discharge except by written instrument signed by the County and Contractor, but no fixed-price contract may be increased by more than twenty-five percent (25%) of the amount of the contract or \$50,000, whichever is greater, without the advance written approval of the County's Board. In no event may the amount of any contract, without adequate consideration, be increased for any purpose, including, but not limited to, relief of an offeror from the consequences of an error in its bid or offer.
- b. The County may, but is not obligated to, extend the term of an existing contract for services to allow completion of any work undertaken but not completed during the original term of the contract.

- c. Nothing in this Section 53 shall prevent the County from placing greater restrictions on contract modifications.

54. **INDEMNIFICATION**. Contractor agrees to indemnify, keep and save harmless the County, its officers, agents, officials, employees and volunteers against any and all claims, claims of injuries, death, damage to property, patent claims, suits, liabilities, judgments, losses, costs and expenses, including but not limited to costs of investigation, all reasonable attorneys' fees (whether or not litigation results), and the cost of any appeal, occurring or arising in connection with the Contractor's, its agents', subcontractors', employees', or volunteers' negligence or wrongful acts or omissions in connection with its performance of any Contract. The Contractor shall, at his or her own expense, appear, defend and pay all charges of attorneys and all costs and other expenses arising therefrom or incurred in connection therewith; and if any judgment shall be rendered against the County in any such action, the Contractor shall, at his or her own expenses, satisfy and discharge the same. Contractor expressly understands and agrees that any performance bond or insurance protection required by any Contract, or otherwise provided by the Contractor, shall in no way limit the responsibility to indemnify, keep and save harmless and defend the County as herein provided. Nothing contained in this Solicitation or the Contract shall be deemed to be a waiver of the County's sovereign immunity.

55. **DRUG-FREE WORKPLACE**. Pursuant to Virginia Code § 2.2-4312, in every Contract over \$10,000.00 the following provisions apply. During the performance of any Contract, the Contractor agrees to (i) provide a drug-free workplace for the Contractor's employees; (ii) post in conspicuous places, available to employees and applicants for employment, a Statement notifying employees that the unlawful manufacture, sale, distribution, dispensation, possession, or use of a controlled substance or marijuana is prohibited in the Contractor's workplace and specifying the actions that will be taken against employees for violations of such prohibition; (iii) state in all Solicitations or advertisements for employees placed by or on behalf of the Contractor that the Contractor maintains a drug-free workplace; and (iv) include the provisions of the foregoing clauses in every subcontract or purchase order of over \$10,000, so that the provisions will be binding upon each subcontractor or vendor.

For the purposes of this Section, "*drug-free workplace*" means a site for the performance of work done in connection with a specific Contract awarded to a Contractor in accordance with this the VPPA and the County's Procurement Procedures, the employees of whom are prohibited from engaging in the unlawful manufacture, sale, distribution, dispensation, possession or use of any controlled substance or marijuana during the performance of the Contract.

56. **TERMINATION**. Contracts will remain in force for full periods specified and/or until all articles ordered before date of termination shall have been satisfactorily delivered and accepted and thereafter until all requirements and conditions shall have been met, unless.

- a. Terminated prior to expiration date by satisfactory deliveries of entire Contract requirements;

- b. Terminated by the County upon thirty (30) days written notice to the Contractor at the County's convenience in the County's sole discretion ("termination for convenience"), unless a termination for convenience is specifically and expressly prohibited by the Contract. Any Contract cancellation notice shall not relieve the Contractor of the obligation to deliver and/or perform on all outstanding orders issued prior to the effective date of the termination;
 - c. Terminated by the County for cause, default or negligence on the part of the Contractor. However, pursuant to Section 51 of these General Conditions, the County may hold the Contractor responsible for any resulting additional purchase and administrative costs. There is no advance notice requirement in the event of Termination for Cause and termination is effective immediately upon notice to Contractor of the termination for cause;
 - d. Extended upon written authorization of County and accepted by Contractor, to permit ordering of unordered balances or additional quantities at Contract prices and in accordance with Contract terms.
57. **APPROPRIATIONS.** Notwithstanding any other provision of any Contract, the payment of the County's obligations under any Contract shall be subject to annual appropriations by the Board of Supervisors of the County in each fiscal year of monies sufficient to satisfy the same.
58. **REFERENCES TO VIRGINIA LAW.** Any reference in these General Conditions to the Code of Virginia or other relevant Federal, State or local law is incorporated in whole herein by reference as in effect at the time of the Solicitation or Contract as such statutory provisions may be amended or replaced by any statute dealing with the same or similar subject matter.
59. **COOPERATIVE PROCUREMENT.** Except as prohibited by the current Code of Virginia, all resultant Contracts will be extended to other Public Bodies of the Commonwealth of Virginia, to permit their ordering of Goods, supplies and/or Services at the prices and terms of the resulting Contract ("cooperative procurement"). By submitting any Bid or entering into any Contract with the County a Bidder/Contractor expressly authorizes cooperative procurement under Virginia Code § 2.2-4304 to the full extent permitted by law. If any other public body decides to use any Contract, the Contractor must deal directly with that public body concerning all matters relating thereto, including but not limited to, the placement or orders, issuance of the purchase order, contractual disputes, invoicing and payment. The County acts only as the "Contracting Agent" for these public bodies. Any resulting contract with other public bodies shall be governed by the laws of that specific entity. It is the Contractor's responsibility to notify the public bodies of the availability of the Contract. Fluvanna County shall not be held liable for any direct or indirect costs, damages or other claim of any kind incurred by another public body or any Contractor as a result of any cooperative procurement.
60. **AUDIT.** The Contractor hereby agrees to retain all books, records and other documents relative to any Contract for five (5) years after final payment, or until audited by the County, whichever is sooner. The County, its authorized agents, and/or County auditors shall have full access to and right to examine any of said materials during said period.

61. **GUARANTIES AND WARRANTIES.** All guarantees, representations and warranties required shall be furnished by the Contractor and shall be delivered to the Purchasing Agent before final payment on any Contract is made. In addition to any guarantees, representations and warranties required under the Contract, the Contractor agrees to.
- a. Save the County, its agents and employees harmless from liability of any nature or kind for the use of any copyrighted or un-copyrighted composition; secret process, patented or unpatented; invention; article or appliance furnished or used in the performance of a Contract for which the Contractor is not the patentee, assignee, licensee or owner;
 - b. Protect the County against latent defective material or workmanship and to repair or replace any damages or marring occasioned in transit or delivery;
 - c. Furnish adequate protection against damage to all work and to repair damages of any kind to the building or equipment, to the Contractor's own work or to the work of other contractors, for which the Contractor's workers are responsible;
 - d. Pay for all permits, licenses and fees and give all notices and comply with all laws, ordinances, rules and regulations of the County; and
 - e. Protect the County from loss or damage to County owned property while it is in the custody of the Contractor;
 - f. At minimum supply all Goods or Services with the manufacturer's standard warranty, if applicable; and
 - g. For any Contract involving Services of any nature, the Contractor further agrees to.
 - (1) Enter upon the performance of Services with all due diligence and dispatch, assiduously press to its complete performance, and exercise therein the highest degree of skill and competence;
 - (2) Allow Services to be inspected or reviewed by an employee of the County at any reasonable time and place selected by the County;
 - (3) Acknowledges that the County shall be under no obligation to compensate Contractor for any Services not rendered in strict conformity with the Contract; and
 - (4) Stipulates that the presence of a County Inspector shall not lessen the obligation of the Contractor for performance in accordance with the Contract requirements, or be deemed a defense on the part of the Contractor for infraction thereof. The Inspector is not authorized to revoke, alter, enlarge, relax, or release any of the requirements of any Contract. Any omission or failure on the part of the Inspector to disapprove or reject any work or material shall not be construed to be an acceptance of any such defective work or material.

62. **PRICE REDUCTIONS.** If at any time after the date of the Bid/Contract the Contractor makes a general price reduction in the comparable price of any material covered by the Contract to customers generally, an equivalent price reduction based on similar quantities and/or considerations shall apply to any Contract for the duration of the Contract period (or until the price is further reduced). Such price reduction shall be effective at the same time and in the same manner as the reduction in the price to customers generally. For purpose of this provision, a "general price reduction" shall mean any horizontal reduction in the price of an article or service offered (1) to Contractor's customers generally, or (2) in the Contractor's price schedule for the class of customers, i.e., wholesalers, jobbers, retailers, etc., which was used as the basis for bidding on this Solicitation. An occasional sale at a lower price, or sale of distressed merchandise at a lower price, would not be considered a "general price reduction" under this provision. The Contractor shall submit his or her invoice at such reduced prices indicating on the invoice that the reduction is pursuant to the "Price Reduction" provision of the Contract documents. The Contractor in addition will within ten (10) days of any general price reduction notify the County of such reduction by letter. FAILURE TO DO SO IS A DEFAULT UNDER THE CONTRACT AND MAY RESULT IN TERMINATION OF THE CONTRACT IN THE COUNTY'S DISCRETION. The Contractor, if requested, shall furnish, within ten (10) days after the end of the Contract period, a statement certifying either (1) that no general price reduction, as defined above, was made after the date of the Bid or Contract, or (2) if any such general price reductions were made, that as provided above, they were reported to the County within ten (10) days and the County was billed at the reduced prices. Where one or more such general price reductions were made, the statement furnished by the Contractor shall include with respect to each price reduction (1) the date when notice of any such reduction was issued, (2) the effective date of the reduction, and (3) the date when the County was notified of any such reduction.
63. **COMPLIANCE WITH IMMIGRATION LAW.** Pursuant to Virginia Code § 2.2-4311.1, in every Contract the following provision applies. the Contractor does not, and shall not during the performance of the Contract, knowingly employ an unauthorized alien as defined in the federal Immigration Reform and Control Act of 1986.
64. **VIRGINIA STATE CORPORATION COMMISSION.** Pursuant to Virginia Code § 2.2-4311.2, Any Bidder or Contractor organized as a stock or non-stock corporation, limited liability company, business trust, or limited partnership or registered as a registered limited liability partnership shall be authorized to transact business in the Commonwealth as a domestic or foreign business entity if so required by Title 13.1 or Title 50 of the Code of Virginia, or as otherwise required by law, at the time of the Bid, Proposal or any response to Solicitation and during the term of the Contract and any Contract renewal. The Contractor shall not allow its existence to lapse or its certificate of authority or registration to transact business in the Commonwealth, if so required, to be revoked or cancelled at any time during the term or any renewal of the Contract. If the Contractor fails to remain in compliance with the provisions of this Section 64, the Contract may become void at the option of the County.
65. **CLAIMS PROCEDURE**

- a. The procedure for consideration by the County of contractual claims for any Contract shall be that set forth in Virginia Code § 15.2-1243, *et seq.*
 - b. In addition, pursuant to Virginia Code § 2.2-4364, contractual claims, whether for money or other relief, shall be submitted in writing to the County Administrator no later than sixty (60) days after final payment; however, written notice of the Contractor's intention to file such claim shall have been given at the time of the occurrence or beginning of the work upon which the claim is based. Nothing herein shall preclude a Contract from requiring submission of an invoice for final payment within a certain time after completion and acceptance of the work or acceptance of the Goods. Pendency of claims shall not delay payment of amount agreed due in the final payment.
 - c. No written decision denying a claim or addressing issues related to the claim shall be considered a denial of the claim unless the written decision is signed by the Board or the County Administrator. The contractor may not institute legal action prior to receipt of the final written decision on the claim unless the County fails to render a decision within ninety (90) days of submission of the claim. Failure of the County to render a decision within ninety (90) days shall not result in the contractor being awarded the relief claimed or in any other relief or penalty. The sole remedy for the County's failure to render a decision within 90 days shall be the contractor's right to institute immediate legal action.
 - d. A Contractor may not institute legal action, prior to receipt of the County's decision on the claim, unless the County fails to render such decision within the time specified by law. A failure by the County to render a decision within the time provided by law shall be deemed a final decision denying the claim by the County.
 - e. The decision of the Board or the County Administrator shall be final and conclusive unless the Contractor appeals within six (6) months of the date of the final written decision by instituting legal action as provided in Virginia Code § 2.2-4364.
 - f. No administrative appeals procedure pursuant to Virginia Code § 2.2-4365 has been adopted for contractual claims by the County.
 - g. Nothing herein shall be construed to prevent the County from instituting legal action against any Contractor or Bidder.
66. **NOTICES.** All written notices required or permitted under any Solicitation, Bid or Contract shall be deemed sufficient if delivered in person to the County Purchasing Agent or Bidder/Contractor, as applicable, or sent by first class mail to the County or Bidder/Contractor at the addresses set forth in the Solicitation, Bid or Contract or at such other address as a party may designate from time to time by notice given in accordance with the terms of this Section 66; except that where a Solicitation, Bid or Contract expressly requires notice to a specific individual or at a specific location, such shall control. Such notices are deemed received when actually delivered to the party or its representative or agent if hand delivered, or one (1) business day after deposited into the United States mail, if mailed.

DELIVERY

67. **SHIPPING INSTRUCTIONS-CONSIGNMENT.** Unless otherwise specified in the Solicitation or Contract, as applicable, each case, crate, barrel, package, etc., delivered under the Contract must be plainly stenciled or securely tagged, stating the Contractor's name, purchase order number, and delivery address as indicated in the order. Where shipping containers are to be used, each container must be marked with the purchase order number, name of the Contractor, the name of the item, the item number, and the quantity contained therein. Deliveries must be made within the hours of 8.00 a.m. – 3.00 p.m. Deliveries at any other time will not be accepted unless specific arrangements have been previously made with the designated individual at the delivery point. No deliveries will be accepted on Saturdays, Sundays and holidays unless previous arrangements have been made. It shall be the responsibility of the Contractor to insure compliance with these instructions for items that are drop-shipped.
68. **RESPONSIBILITY FOR SUPPLIES TENDERED.** The Contractor shall be responsible for the materials or supplies covered by the Contract until they are delivered at the designated point. The Contractor shall additionally bear all risk on rejected materials or supplies after notice of rejection is tendered by the County. Rejected materials or supplies must be removed by and at the expense of the Contractor promptly after notification of rejection, unless public health and safety require immediate destruction or other disposal of rejected delivery. If rejected materials are not removed by the Contractor within ten (10) days after date of notification, the County may return the rejected materials or supplies to the Contractor at the Contractor's risk and expense or dispose of them as abandoned property.
69. **INSPECTIONS.** The County reserves the right to conduct any test/inspection it may deem advisable to assure supplies and Services conform to the specification in the Solicitation, Bid or Contract, as applicable. Inspection and acceptance of materials or supplies will be made after delivery at destinations herein specified unless otherwise stated. Unless otherwise specified in the Contract, if inspection is made after delivery at the destination specified, the County will bear the expense of inspection except for the value of samples used in case of rejection. Final inspection shall be conclusive except in regard to latent defects, fraud or such gross mistakes as to amount to fraud. Final inspection and acceptance or rejection of the materials or supplies will be made as promptly as practicable, but failure to inspect and accept or reject materials or supplies shall not impose liability on the County for such materials or supplies as are not in accordance with the specifications.
70. **COMPLIANCE.** Delivery must be made as ordered and in accordance with the Solicitation, Bid or Contract, as applicable, or as directed by the County when not in conflict with the Bid/Contract. The decision as to reasonable compliance with delivery terms shall be final. Burden of proof of delay in receipt of Goods by the purchaser shall rest with the Contractor. Any request for extension of time of delivery from that specified must be approved by the County, such extension applying only to the particular item or shipment affected. Unless otherwise specified in the Contract, should the Contractor be unreasonably delayed by the County, there shall be added to the time of completion a time equal to the period of such delay caused by the County. However, the Contractor shall not be entitled to claim damages or extra

compensation for such delay or suspension. These conditions may vary for construction Contracts.

71. **POINT OF DESTINATION.** All materials shipped to the County must be shipped F.O.B. DESTINATION unless otherwise stated specifically in the Solicitation, Bid or Contract, as applicable. The materials must be delivered to the “Ship To” address indicated on the purchase order or Solicitation, as applicable.
72. **REPLACEMENT.** Materials or components that have been rejected by the County, in accordance with the terms of the Contract, shall be replaced by the Contractor at no cost to the County.
73. **DAMAGES.** Any and all damages to property of the “County” that is the direct result of the Contractor, the employees of the Contractor and/or its subcontractors, agents, licensees, successors, or assigns, shall be the sole responsibility of the Contractor. The property shall be repaired to its last known condition prior to the damages and/or replaced at no cost to the County. The County shall approve any and all repairs/replacements prior to acceptance of the repairs/replacement.
74. **PACKING SLIPS OR DELIVERY TICKETS.** All shipments shall be accompanied by Packing Slips or Delivery Tickets and shall contain the following information for each item delivered.
 - a. Purchase Order Number;
 - b. Name of Article and Stock Number;
 - c. Quantity Ordered;
 - d. Quantity Shipped;
 - e. Quantity Back Ordered; and
 - f. The Name of the Contractor.

Contractors are cautioned that failure to comply with these conditions shall be considered sufficient reason for refusal to accept the Goods.

75. **ADDITIONAL CHARGES.** No delivery charges of any kind shall be added to any invoice; except that (i) if Goods are expressly bought F.O.B. "shipping point" under the Contract and the Contractor prepays transportation, then delivery charges shall be added to invoices; and (ii) if express delivery is authorized and substituted by the County on orders for the method specified in the Contract, then the difference between freight or mail and express charges may be added to invoice.

76. **METHOD AND CONTAINERS.** Unless otherwise specified, Goods shall be delivered in commercial packages in standard commercial containers, so constructed as to ensure acceptance by common or other carrier for safe transportation to the point of delivery. Containers become the property of the County unless otherwise specified by bidder.

EXHIBIT B
INTERGOVERNMENTAL AGREEMENT

INTERGOVERNMENTAL AGREEMENT

This **Intergovernmental Agreement (“Agreement”)** to establish a Shared Public Safety Radio System referred to herein as the **“Piedmont Public Safety Communications System” (“Piedmont System”)**, is entered into this ____ day of _____, 2018, between **Fluvanna County (“Fluvanna”)** and **Louisa County (“Louisa”)**, both political subdivisions of the Commonwealth of Virginia, together **“Parties”** (Fluvanna and Louisa may be referred to individually as a **“Party”**).

RECITALS

WHEREAS, each of the Parties has the power to establish a system that serves the fire, rescue, law enforcement, emergency, and other radio communications of their respective localities;

WHEREAS, Fluvanna purchased an Astro VHF Simulcast P25 Public Safety Communications System which includes a System Core, as defined in Article 1, (collectively the “Fluvanna System”) from Motorola Solutions, Inc., in 2015 pursuant to the Communications System Agreement to provide radio communications for Fluvanna public safety personnel, replacing an existing four-channel conventional radio system;

WHEREAS, Fluvanna initially financed its purchase of the Fluvanna System and has since refinanced with TD Equipment Finance, Inc. under that Equipment Lease Purchase Agreement dated October 31, 2016 with the Fluvanna System financing scheduled to be paid in full on September 1, 2023 based upon the terms of such agreement;

WHEREAS, Louisa also purchased an Astro VHF Simulcast P25 Public Safety Communications System (“Louisa System”) from Motorola Solutions, Inc., in 2017 pursuant to an agreement, without a system core, to replace the existing conventional VHF simulcast system, with an anticipated cutover date in December 2018;

WHEREAS, Louisa paid for its purchase of the Louisa System to operate in conjunction with the Fluvanna Core and with the intent of utilizing the Fluvanna Core. Said purchase price was derived in total from appropriated funds from Louisa County’s General Fund, and specifically from its Capital Improvement Budget. All additional monies required by Louisa County to comply with the terms of this Agreement shall be derived from appropriations from its General Fund. Nothing contained herein, however, shall obligate future boards of supervisors to appropriate funds for this purpose;

WHEREAS, the Fluvanna System was designed with the System Core configured to host both the Fluvanna and the Louisa public safety communication radio systems and to accommodate potential future regional collaboration and sharing of the System Core;

WHEREAS, it is the intent of the Parties that the Piedmont System be able to accommodate several independent simulcast cells that share a common System Core, and that the System Core may be expanded in the future by upgrading the System Core to host additional public safety communication radio systems beyond supporting only the Fluvanna System and Louisa System;

WHEREAS, pursuant to Section 15.2-1300 of the Code of Virginia, 1950, as amended (the “Code”), the Parties have determined to jointly exercise their powers with respect to the Piedmont System (as defined below), as provided for in this Agreement, whose governing bodies have adopted ordinances as required by Section 15.2-1300 of the Code, approving this Agreement in furtherance thereof; and

WHEREAS, the Parties desire to enter into this Agreement for the purpose of creating the Piedmont System, providing for the operation thereof, providing for the maintenance, upgrade and operation of the System Core and related matters and to govern the relationship among the Parties related to the foregoing, as required under Section 15.2-1300 of the Code.

AGREEMENT

THAT FOR AND IN CONSIDERATION of the mutual covenants and agreements contained herein, and the above recitals which are incorporated by reference herein, the Parties hereto pursuant to the provisions of Section 15.2-1300 of the Code of Virginia (1950), as amended, do covenant and agree to the following:

ARTICLE I: DEFINITIONS

“Agreement” shall mean this Intergovernmental Agreement, and any and all amendments hereto.

“Piedmont System” shall mean that system of public safety communications radio systems that use the System Core established by the Parties under this Agreement.

“Radio System Assets” shall mean system assets and equipment required for the operation of each Party’s system, and shall include and not be limited to, buildings, dispatch center furniture, fences, generators, grounding systems, HVAC systems, rights of way, roadways, site leases, towers, uninterruptible power supplies (UPS), the fire-alerting equipment, other fixed network equipment (*excluding the System Core*), and subscriber equipment (mobile and portable radios).

"System Core" shall mean the “Motorola L2 Core VHF-TDMA,” which is operated from and located at the Fluvanna County Sheriff’s Office, 160 Commons Blvd., Palmyra, VA 22963; and is more specifically described by Appendices A and B.

"System Managers" shall mean the County Administrators or their designees, who shall be responsible for the management and operation of their locality's respective share of the Piedmont System.

ARTICLE II: REPRESENTATIONS AND WARRANTIES

Each of the Parties respectively make the following representations and warranties, all of which shall continue for the duration of this Agreement:

a. It has full power and authority to enter into this Agreement and to consummate and carry out the transactions contemplated by this Agreement. It has taken, or will take, all action required by this Agreement and other applicable laws in connection therewith;

b. It has duly authorized the execution and delivery of this Agreement by ordinance adopted by its governing body;

c. The execution and delivery of this Agreement and the performance of its obligations hereunder are within its powers, and will not conflict with, or constitute a breach or result in a violation of (1) any Federal or Virginia Constitutional or statutory provision, (2) in any material respect, any agreement or other instrument to which such party is a party or by which it is bound, or (3) any order, rule, regulation, decree or ordinance of any court, government or governmental authority having jurisdiction over it or its property;

d. There is no litigation at law or in equity or any proceeding before any governmental agency

pending or, to its knowledge, threatened with respect to (1) its existence, (2) its authority to execute and deliver this Agreement, (3) the validity or enforceability of this Agreement or the contemplated hereby, (4) the title of its officers who are executing this Agreement, or (5) any authority or proceedings relating to its execution and delivery of this Agreement; and

- e. It is a duly organized and validly existing political subdivision of the Commonwealth of Virginia.

ARTICLE III: DURATION OF AGREEMENT

This Agreement shall take effect upon its proper execution by both Parties after adoption of an ordinance related to the Agreement by each party as required by the Code. The initial term of this Agreement shall be twenty-five (25) years following the date of this Agreement, unless otherwise terminated by the Parties as provided in Article VIII. Upon expiration of the term of the Agreement, this Agreement may be renewed for three (3) subsequent terms of five (5) years each upon the written mutual agreement of the parties. This Agreement shall terminate upon non-renewal, in accordance with Article VIII, or as otherwise stated in this Agreement.

ARTICLE IV: PURPOSE

The purpose of this Agreement is to provide the terms and conditions of the joint undertaking of the parties hereto with respect to the Piedmont System and common use of the System Core as required by Section 15.2-1300 of the Code. The joint undertaking will involve shared operation, use, maintenance, and potential expansion and upgrades of the System Core, and all other things necessary or proper to carry out the foregoing purposes.

ARTICLE V: SYSTEM ACQUISITION AND MAINTENANCE COSTS

Section 5.1 - PIEDMONT SYSTEM PARTY "BUY IN"

- a. The Parties acknowledge and agree that Fluvanna has installed the Fluvanna Radio System Assets including the System Core, at its sole expense.

- b. The Parties acknowledge and agree that Louisa has contracted for purchase of the Louisa Radio System Assets, at its sole expense, without a System Core.

- c. The Parties agree that Louisa will pay to Fluvanna one-half of the initial acquisition and installation cost of the System Core shown in Appendix C, with such amount determined to be \$380,689.03 as Louisa's required contribution to become a Party in the Piedmont System. Louisa agrees to pay such amount to Fluvanna within ten (10) days of the date Louisa and Motorola Solutions, Inc., agree to system acceptance for the Louisa System under the contract for the purchase of the Louisa System, or the date that the Louisa System is being used for public safety radio communications by Louisa and is connected to the System Core, whichever is sooner. Should Louisa fail to make the payment to Fluvanna required by this Section 5.1(c) within forty-five (45) days of the date due, then at Fluvanna's option and upon written notice to Louisa this Agreement shall immediately terminate and Fluvanna shall own the System Core and Louisa shall have no rights of use of or ownership in the System Core and any payments previously made by Louisa related to this Agreement shall not be refunded or repaid.

- d. In anticipation of such payment specified above and at Louisa's sole cost and expense, Louisa will be allowed to connect to the System Core via microwave backhaul from the Fluvanna communications tower (the "Tower") located at 1214 Salem Church Road, Palmyra, Virginia 22963 at the location identified in Appendix D hereto.

(1) Louisa shall pay the cost of any and all utilities, emergency generator, insurance, security, maintenance or services/items it requires for its Radio System Assets at the Tower.

(2) Any use by Louisa of the Tower cannot interfere with any rights of the Central Virginia Electric Cooperative (CVEC) or Fluvanna under that deed dated the 25th day of August, 2017, from CVEC to the County of Fluvanna recorded in the Circuit Court Clerk's Office of the County of Fluvanna in Deed Book 993, page 685 (the "CVEC deed").

(3) Louisa agrees it shall abide by all terms of the CVEC deed and further that it shall not cause any interference with the provisions thereof.

(4) Should any use by Louisa of the Tower disturb either Fluvanna or CVEC or cause any breach or violation of any provision of the CVEC deed, then Fluvanna may upon written notice to Louisa require Louisa to vacate the Tower within a reasonable period of time stated in such notice (being at least 30 days) at Louisa's sole expense and Louisa shall be required remove all of its Radio System Assets from the Tower, Louisa shall be required to find another tower or telecommunications facility to locate on so as to connect to the System Core at Louisa's sole cost and expense. Fluvanna's right to exercise the remedy provided in this paragraph shall be conditioned on having provided Louisa a 30-day period in which to cure any breach or condition causing such breach. Should Louisa be required to vacate pursuant to this paragraph, Louisa shall be immediately relieved of all then-existing and future obligations under this Agreement.

(5) Louisa understands such may result in a disruption to services of the Louisa System and further agrees that any relocation shall not alter, modify or change any other requirement or provision of this Agreement even during a disruption of service.

Section 5.2 - SYSTEM CORE. The Parties further agree that the costs for the ongoing maintenance, repair, replacement, upgrades, enhancements and insuring of the System Core from the date of execution of this Agreement shall be shared equally by the Parties. Fluvanna has already entered into a "1st Addendum to the Communications System Agreement for the Fluvanna Public Safety Emergency Communications Radio System for Maintenance Services" (the "Maintenance Agreement") with Motorola Solutions, Inc. dated December 20, 2017, for continued maintenance of the System Core, including Astro 25 Advanced and Advanced Plus Maintenance Services, until June 30, 2022 and Louisa has reviewed such agreement and approves of the same and agrees to pay for fifty-percent of the costs thereof relating to the System Core. Fluvanna has entered into certain other agreements relating to the System Core that pre-date this Agreement including: NONE. Louisa shall pay its equal share of the system core maintenance cost under the Maintenance Agreement (as shown in Appendix E) and of these Other System Agreements.

Section 5.3 – SOFTWARE UPGRADES & ANTIVIRUS. The Parties agree that it is imperative that the proper software versions and antivirus signatures be maintained to ensure compatibility between their respective systems. The Parties shall be jointly and equally responsible for the costs associated with software upgrades. The Parties further agree to enter into a Software Upgrade Assurance (SUA2) plan with Motorola Solutions, Inc. to ensure proper System Core lifecycle maintenance, and that the Parties will operate on the same software version (initially at version 7.16).

Section 5.4 – OTHER SHARED COSTS. Maintenance or other costs not covered by an existing contract will be agreed to in advance by each Party and each Party shall be responsible for fifty-percent of the costs thereof. Fluvanna may in its sole discretion pay any System Core costs or costs on account of the Piedmont System in full and then invoice Louisa for reimbursement of fifty-percent of the costs. All invoices from either Party shall be paid in full by the other Party within 30 days of the invoice date.

a. Agreements for any services relating to the System Core after execution of this Agreement shall be procured in a manner consistent with applicable law as joint procurements by both Parties with each Party's System Manager on the committee for review of any request for proposals, if applicable, or invitation for bids, if applicable. Small procurements may be negotiated by Fluvanna and shall be accepted and entered into by Louisa so long as reasonable and appropriate subject to a written contract executed by both Parties and the third-party contractor.

b. Overhaul or replacement of major units such as a generator, tower, or UPS, will be the responsibility of the Party that owns the equipment that is to be replaced.

Section 5.5 – CONTRACTING SERVICES. Fluvanna shall serve as the default contracting agent as it pertains to this agreement for System Core issues, including the acquisition of insurance, maintenance contracts, etc. Louisa may serve as contracting agent for a System Core issue if Fluvanna agrees to the same in advance. The respective System Managers shall review the terms and specifications of such proposed acquisitions before Fluvanna and Louisa enter into any contract and upon any modifications of a contract subject to any required approvals by Louisa or Fluvanna (with specific understanding that the policy of Louisa or Fluvanna may require approval by the Board of Supervisors of either or both Parties prior to execution). All contracts shall comply with the Virginia Public Procurement Act and must be properly approved by Louisa and Fluvanna consistent with each Party's procurement policy. Fluvanna shall bill Louisa for their portion of any costs paid by Fluvanna on Louisa's behalf as specified in this Agreement. Notwithstanding anything contained in this Agreement to the contrary, in the event the funds appropriated by either Louisa or Fluvanna for any costs contemplated hereunder or other amounts due under this Agreement are insufficient therefor, this Agreement shall terminate on the last day of the fiscal period for which appropriations were received without penalty and Section 8.2 shall control disposition of joint equipment.

Section 5.6 - RADIO SYSTEM ASSETS. The Parties agree that the contracting services and costs for acquisition, maintenance, repair, upgrade, replacement, and insuring of their respective Radio System Assets other than the System Core shall be the sole responsibility of the Party who owns the equipment/asset.

Section 5.7 - SYSTEM MANAGER RESPONSIBILITIES. The Piedmont System Managers will jointly develop and implement policies and procedures necessary for the efficient and effective operation and maintenance of the System Core. In addition, they will oversee day-to-day maintenance functions of the System Core and be responsible for administrative functions, including billing for maintenance. Finally, they will develop a record keeping system adequate to facilitate the effective administration of this Agreement.

ARTICLE VI: PIEDMONT SYSTEM EXPANSION

Section 6.1 - FUTURE PIEDMONT SYSTEM EXPANSION. When the capacity of the System Core is no longer adequate to meet the aggregate needs of the Parties, or as new technologies emerge that will provide an improved radio system, the Parties may agree to jointly pursue the acquisition of additional frequencies or equipment necessary to utilize such technologies or frequencies. Should the parties agree that it is in their best interest to purchase additional equipment, a mutually agreeable cost sharing arrangement shall be negotiated by the Parties for the acquisition of such necessary equipment, and incorporated as an amendment to this Agreement.

Section 6.2 - ADDITION OF NEW GOVERNMENTAL USERS. The Parties acknowledge that the intent is to add additional localities to the system and Louisa agrees it shall formally agree by written amendment to this Agreement to the addition of any new parties to the Piedmont System if so requested by Fluvanna, provided that the addition of any new party does not substantially and unreasonably

interfere with or limit Louisa's use thereof as contemplated hereunder. If the Piedmont System is expanded beyond the two original localities, the Parties may agree to establish a System Manager position or contract to manage the regional system by written amendment of this Agreement.

ARTICLE VII: CLAIMS AND RESOLUTION OF DISPUTES

Section 7.1 - CLAIMS FOR COSTS OR DAMAGES. In the event that any claim for costs or damages is made against any Party arising out of or as a consequence of the operation of this Agreement, the Parties' System Managers, as defined herein, shall jointly develop and recommend to their governing bodies a proposal for allocation of such costs or damages and for settlement of any claim, if such is required to be paid. If the System Managers are unable to agree to a recommendation, the claim will then be handled in accordance with the procedure for "Resolution of Disputes" as set forth in Section 7.2 below.

Section 7.2 - DISPUTE RESOLUTION

a. Any Piedmont System management issues that cannot be resolved by the System Managers will be referred to Party's County Administrators for review and resolution.

b. The Parties agree that, in the event that there is a disagreement between them regarding compliance with the terms and conditions of this Agreement, for at least 60 days prior to filing any suit the disagreement will be discussed by the Parties in hopes of coming to a mutually agreeable solution and may be submitted by the Parties to a neutral mediator for assistance in reaching a resolution of the disagreement satisfactory to all Parties.

c. Each Party further agrees that, in the event of any breach/default or threatened breach/default by any Party of any covenant, warranty, or obligation contained in this agreement, the non-breaching/non-defaulting Party will be entitled (in addition to any other remedy that may be available, whether in law or equity) to seek (i) a decree or order of specific performance to enforce the observation and performance of such covenant, warranty, or obligation, and (ii) an injunction restraining such breach/default or threatened breach/default.

ARTICLE VIII: TERMINATION OF AGREEMENT

Section 8.1 - RIGHT TO WITHDRAW. Any Party to this Agreement has the right to withdraw from this Agreement at any time prior to the expiration of the initial term upon 60 days' notice to the other Party, and subject to having paid in full any outstanding shared cost then-due and still owed. All prepaid Shared Costs by Louisa shall be refunded in full by no later than 30 days following its withdrawal.

Section 8.2 - DISPOSITION OF JOINT EQUIPMENT. For purposes of this Section 8.2, Outstanding Shared Costs shall mean any outstanding unpaid shared costs under any contracts related to the System Core through the date of termination of this Agreement (with any contract for maintenance, insurance or similar services provided at a flat rate for a set period being prorated to the date of termination of this Agreement). Notwithstanding any other provision hereof, Louisa's required contribution under Section 5.1(c) is not a prepaid Shared Cost, and in no event shall Louisa be entitled to a refund or reimbursement of such required contribution; and further, Fluvanna shall never be required to reimburse or return such required contribution to Louisa.

In the event of termination or cancellation of this Agreement during the initial term under 8.1 owing to a withdrawal and not owing to a default of any Party, the System Core (which term shall include any and all upgrades, enhancements and other modifications thereto under this Agreement) shall become the property of Fluvanna and no reimbursements of any kind shall be made to Louisa for any payments made pursuant

to this Agreement excepting only prepaid Shared Costs. Louisa shall be required to pay to Fluvanna any of its' Outstanding Shared Costs, as defined above. Such payment must be made within thirty (30) days of the date of termination of this Agreement.

In the event of termination or cancellation of this Agreement after the initial term and not owing to a default of any Party, the System Core (which term shall include any and all upgrades, enhancements and other modifications thereto under this Agreement) shall become the property of Fluvanna and no reimbursements of any kind shall be made to Louisa for any payments made pursuant to this Agreement. In addition, Louisa shall be required to pay to Fluvanna any of its' Outstanding Shared Costs, as defined above. Such payment must be made within thirty (30) days of the date of termination of this Agreement.

In the event that Louisa defaults under this Agreement resulting in the termination of this Agreement, the System Core (which term shall include any and all upgrades, enhancements and other modifications thereto under this Agreement) shall become the property of Fluvanna and no reimbursements of any kind shall be made to Louisa for any payments made pursuant to this Agreement. In addition, Louisa shall be required to pay to Fluvanna any of its' Outstanding Shared Costs, as defined above. Such payment must be made within thirty (30) days of the date of termination of this Agreement.

In the event Fluvanna defaults under this Agreement resulting in the termination of this Agreement, the System Core (which term shall include any and all upgrades, enhancements and other modifications thereto under this Agreement) shall become the property of Fluvanna and Fluvanna shall reimburse Louisa for its share of the System Core purchased with joint funds under this Agreement, including the initial acquisition costs and all upgrades and enhancements thereof; however, the reimbursement shall only be current value of the System Core being the original costs thereof less any and all depreciation, as determined by an independent auditor qualified to value public radio systems jointly selected and compensated jointly in equal amounts by all Parties. Reimbursement shall occur within thirty (30) days of the date of termination of this Agreement. In addition, if Fluvanna defaults under this Agreement resulting in a termination of the Agreement, Louisa shall be required to pay any Outstanding Shared Costs, as defined above; less any shared costs prepaid by Louisa under any contracts for the System Core to which Fluvanna is a party (prepaid shall mean only costs for that portion of services not yet rendered as of the date of termination of this Agreement). Such payment must be made within thirty (30) days of the date of termination of this Agreement.

In the event of a termination or cancellation of this Agreement for any reason and after Louisa has paid all of amounts owing to Fluvanna required *supra*, Louisa and Fluvanna shall cooperate to amend any contracts for the System Core executed by both of them to remove Louisa as a party to such contract effective upon the termination of this Agreement.

Section 8.3 - DISPOSITION OF SEPARATE EQUIPMENT. The terminating Party may remove any or all of its own separate equipment, unless the removal of the equipment will render the System inoperable. In such case, the Party may not remove the equipment, but shall be reimbursed pursuant to section 8.2.

ARTICLE IX: MISCELLANEOUS

Section 9.1 - AMENDMENTS. This Agreement represents the entire agreement between the parties and this Agreement may not be amended, modified or otherwise altered without the express written consent of all Parties.

Section 9.2 - SEVERABILITY. If any provision of this Agreement is held invalid by any court of competent jurisdiction, the holding will not invalidate any other provision.

Section 9.3 - APPLICABLE LAW AND COURTS. This Agreement and its terms, including, but not limited to, the parties' obligations under it, and the remedies available to each party for breach of it, shall be governed by, construed and interpreted in accordance with the laws of the Commonwealth of Virginia, and exclusive jurisdiction and venue of any dispute or matters involving litigation between the parties hereto shall be in the courts of Fluvanna County, Virginia. Any jurisdiction's choice of law, conflict of laws, rules, or provisions, including those of the Commonwealth of Virginia, that would cause the application of any laws other than those of the Commonwealth of Virginia, shall not apply. The Contractor shall comply with applicable federal, State and local laws, ordinances, rules and regulations in performance of the Contract.

Section 9.4 - COUNTERPARTS. This Agreement may be simultaneously executed in several counterparts, each of which will be original and all of which taken together will constitute one and the same instrument.

Section 9.5 – TITLES. The titles and section headings herein are inserted solely for convenience and are not to be construed as a limitation on the scope of the provisions to which they refer.

Section 9.6 – ATTORNEYS' FEES. In the event of a dispute between the Parties which cannot be amicably resolved, in addition to all other remedies, the party substantially prevailing in any litigation shall be entitled to recover its reasonable expenses, including, but not limited to, reasonable attorneys' fees.

Section 9.7 – NO WAIVER. Failure of either Party to require compliance with any term or condition of any Contract shall not be deemed a waiver of such term or condition or a waiver of the subsequent enforcement thereof.

Section 9.8 – NO ASSIGNMENT. This Agreement may not be assigned by either Party.

Section 9.9 – NOTICES: All written notices required or permitted under this Agreement shall be deemed sufficient if delivered in person to the County Administrator of the relevant Party or sent by first class mail to the County Administrator at the addresses set forth on the signature page hereto. Such notices are deemed received when actually delivered to the party or its representative or agent if hand delivered, or one (1) business day after deposited into the United States mail, if mailed. Any party may change its address for notices from time to time by written notice of such change to the other.

APPENDICES

- A.** L2 Core Master Site Diagrams
- B.** L2 Core Master Site Inventory
- C.** L2 Core Master Site System Costs
- D.** Tower Antenna Location Diagram
- E.** L2 Core Master Site System Maintenance Costs

IN WITNESS WHEREOF, the parties have caused this Agreement to be executed on their behalf by their duly authorized officers:

FLUVANNA COUNTY

By: _____

Steven M. Nichols
County Administrator
132 Main Street
Palmyra, VA 22932

Date: _____

ATTEST:

By: _____

Date: _____

Title: _____

Authorized pursuant to Ordinance No. _____

Approved as to form: _____
Fluvanna County Attorney

LOUISA COUNTY

By: _____

Christian R. Goodwin
County Administrator
1 Woolfolk Avenue
Louisa, VA 23093

Date: _____

ATTEST:

By: _____

Date: _____

Title: _____

Authorized pursuant to Ordinance No. _____

Approved as to form: _____
Louisa County Attorney

APPENDIX A - L2 CORE MASTER SITE

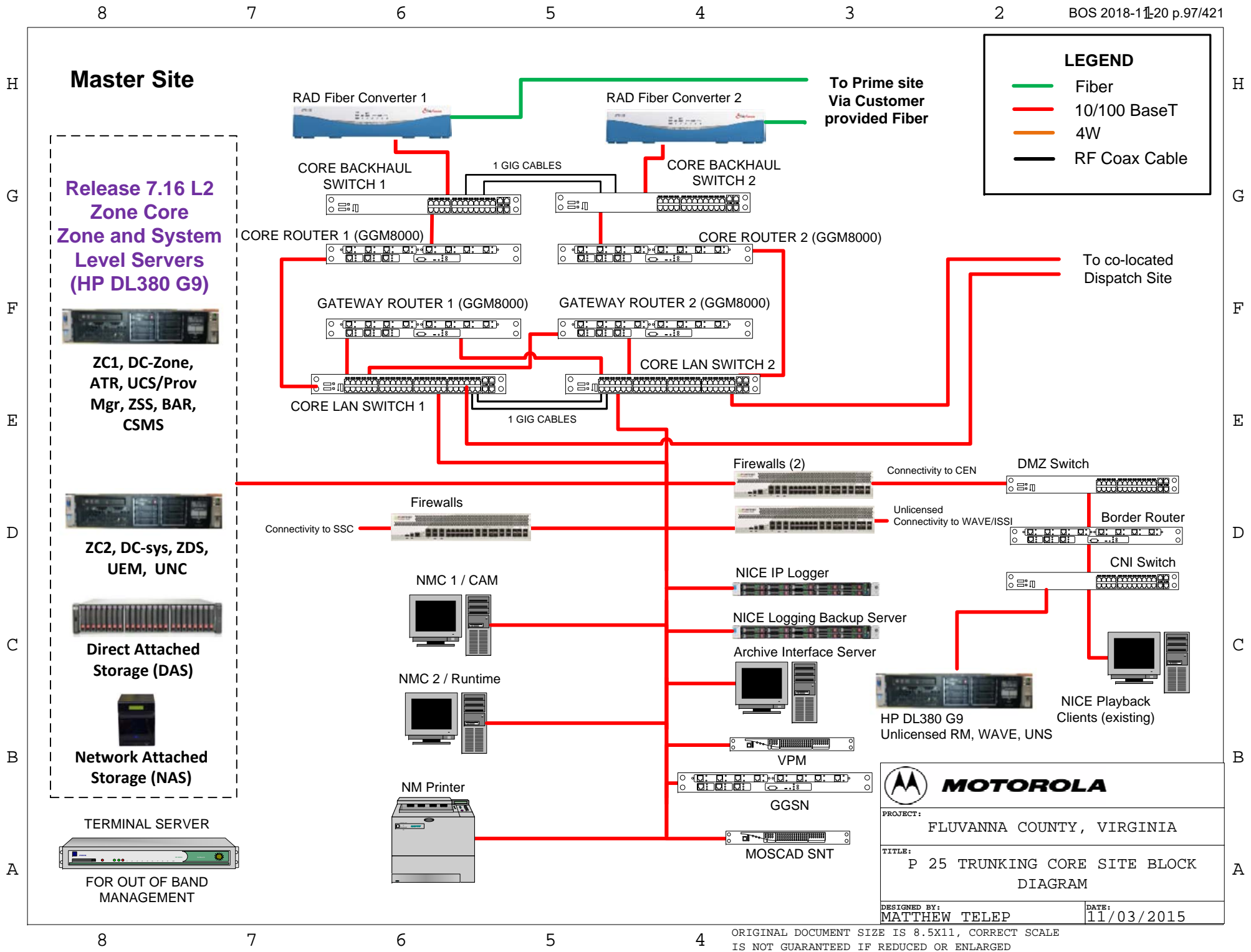

LEGEND

- Fiber (Green line)
- 10/100 BaseT (Red line)
- 4W (Orange line)
- RF Coax Cable (Black line)

Release 7.16 L2 Zone Core Zone and System Level Servers (HP DL380 G9)

- ZC1, DC-Zone, ATR, UCS/Prov Mgr, ZSS, BAR, CSMS
- ZC2, DC-sys, ZDS, UEM, UNC
- Direct Attached Storage (DAS)
- Network Attached Storage (NAS)
- TERMINAL SERVER FOR OUT OF BAND MANAGEMENT

MOTOROLA

PROJECT: FLUVANNA COUNTY, VIRGINIA

TITLE: P 25 TRUNKING CORE SITE BLOCK DIAGRAM

DESIGNED BY: MATTHEW TELEP

DATE: 11/03/2015

LEGEND

- Fiber
- 10/100 BaseT
- 4W
- RF Coax Cable

H
G
F
E
D
C
B
A

H
G
F
E
D
C
B
A

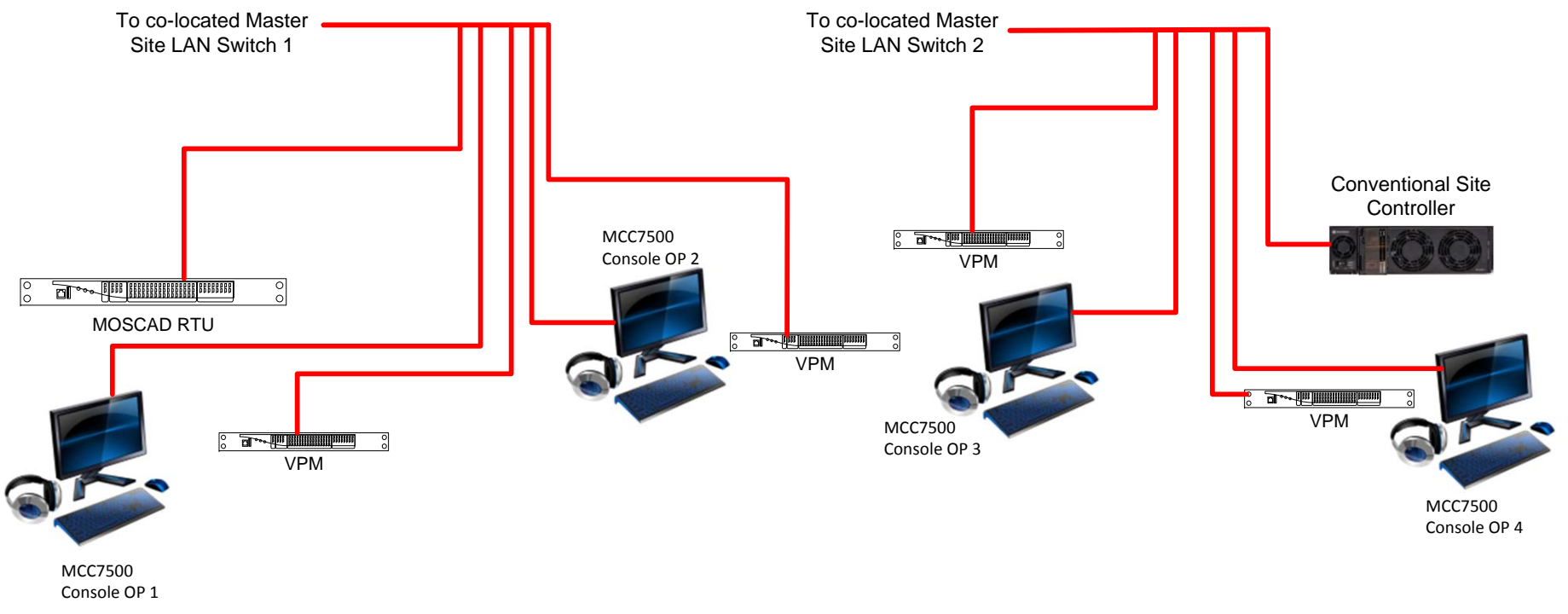

 MOTOROLA	
PROJECT: FLUVANNA COUNTY, VA	
TITLE: DISPATCH SITE BLOCK DIAGRAM	
DESIGNED BY: MATTHEW TELEP	DATE: 11/03/2015

8 7 6 5 4

H

G

F

E

D

C

B

A

H

G

F

E

D

C

B

A

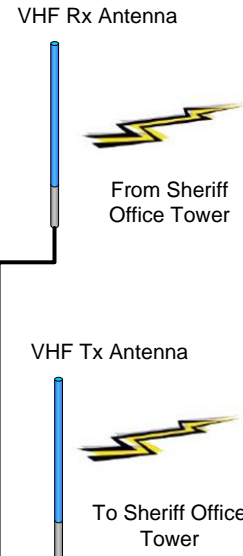
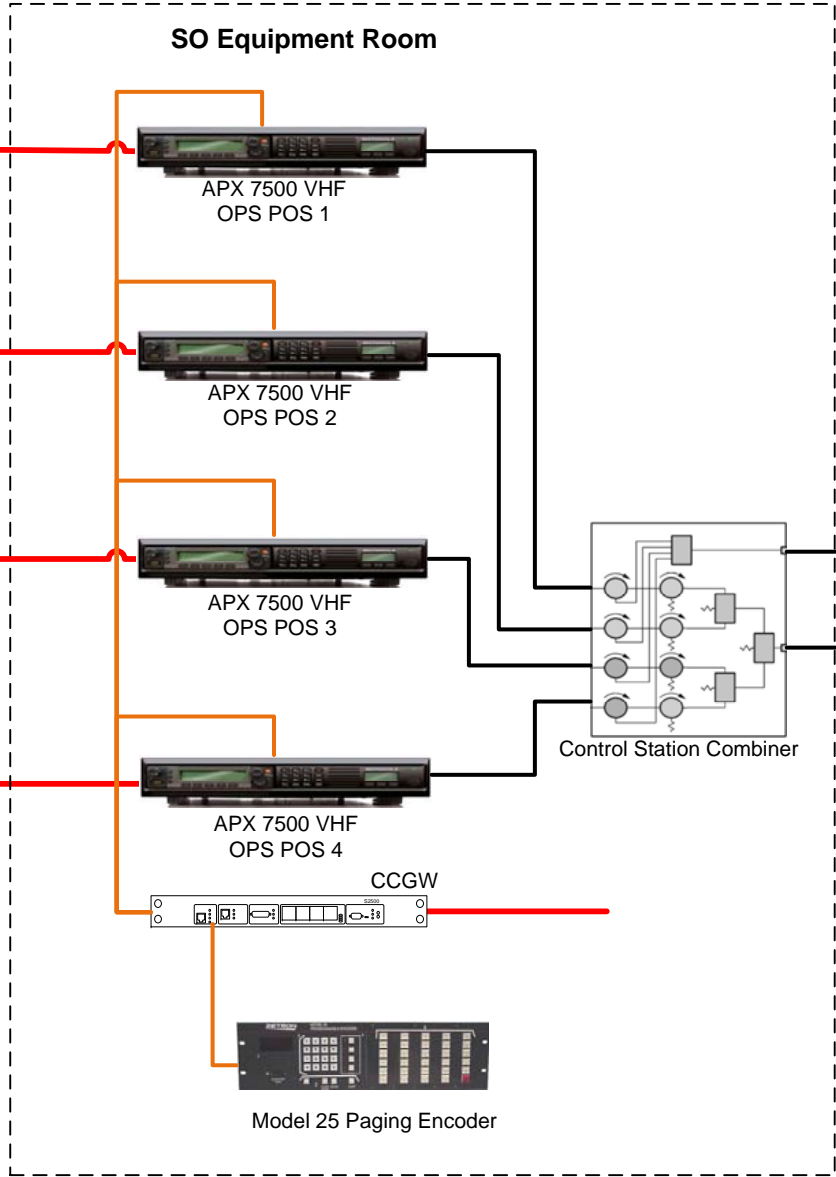

LEGEND

- Fiber
- 10/100 BaseT
- ACIM / 4W
- RF Coax Cable

 **MOTOROLA**

PROJECT: FLUVANNA COUNTY, VA

TITLE: BACKUP CONSOLETTTE NETWORK

DESIGNED BY: MATTHEW TELEP

DATE: 11/03/2015

LEGEND

- Fiber
- 10/100 BaseT
- 4W
- RF Coax Cable

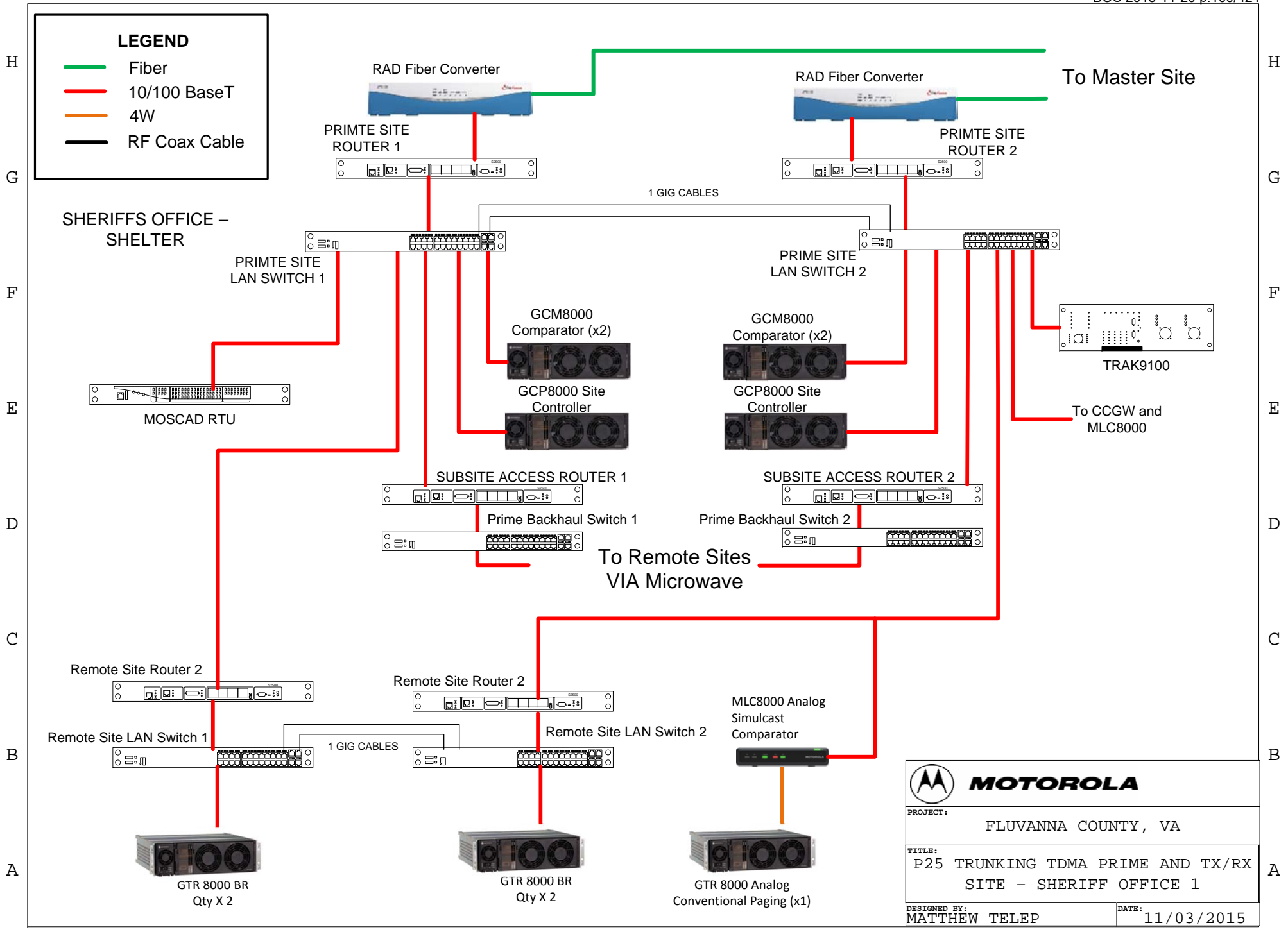

MOTOROLA

PROJECT: FLUVANNA COUNTY, VA

TITLE: P25 TRUNKING TDMA PRIME AND TX/RX SITE - SHERIFF OFFICE 1

DESIGNED BY: MATTHEW TELEP

DATE: 11/03/2015

ECC SHERIFFS OFFICE – SHELTER

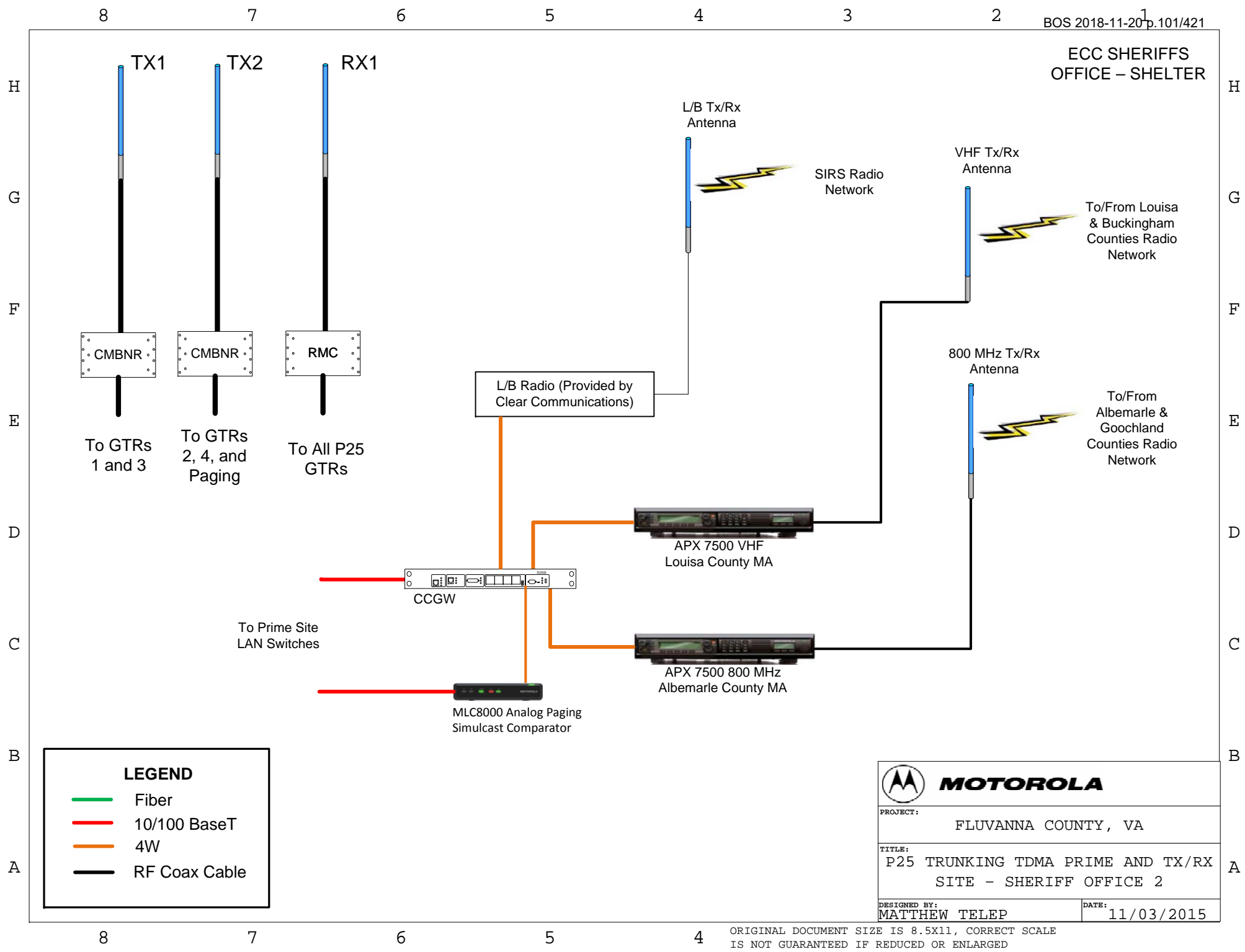

LEGEND

- Fiber
- 10/100 BaseT
- 4W
- RF Coax Cable

MOTOROLA

PROJECT: FLUVANNA COUNTY, VA

TITLE: P25 TRUNKING TDMA PRIME AND TX/RX SITE – SHERIFF OFFICE 2

DESIGNED BY: MATTHEW TELEP DATE: 11/03/2015

Acronym	Name	Definition
4W	4 Wire E&M	4-wire (2-pair) transmission path for the voice signal.
ACIM	Astro Control Interface Module	The ASTRO Control Interface Module (ACIM) feature adds the serial control protocol to the GGM 8000 to allow exchanging control information between an MCC 7500 console and a Motorola consolette.
AIS	Archiving Interface Server	The Archiving Interface Server (AIS) is used to serve audio and related information to third-party call logging hardware for audio archiving at a MCC 7500 Dispatch Console site. The AIS comprises of an Application latform with the appropriate additional elements [hardware (voice cards) and AIS application software]. The AIS acts as an intermediary between the thirdparty audio logging solution and the trunking system, hiding the proprietary interfaces from the third-party audio logging solution.
ATR	Air Traffic Router	A Private Network Management (PNM) server application that receives air traffic information from the Zone Controller, creates Air Traffic Information Access (ATIA) packets, and broadcasts them as the ATIA stream on the network. Various clients listen to this stream to perform their functions. Clients include the Zone Statistics Server (ZSS) and System Statistics Server (SSS), the Radio Control Manager (RCM), Dynamic Reports, ATIA Log Viewer and ZoneWatch applications, Affiliation Display, and other third-party clients. ATR receives, via the Self Managed Network interface, data about Infrastructure, Subscribers and configuration for ZoneWatch, Radio Control Manager (RCM) and Computer Aided Dispatch Interface (CADi).
BAR	Backup and Recovery Server	Provides centralized backup and restore (BAR) services to return the devices to an operational state in an ASTRO® 25 system.
CBS	Core Backhaul Switch	The core backhaul switch provides a link aggregation point for the network at the master site when Ethernet site and interzone links are implemented. Two core backhaul switches are required at the master site for this functionality.
CCGW	Conventional Channel Gateway	A site gateway that enables trunked system users to incorporate analog conventional channels into their dispatch operations without the requirement for separate hardware networks or channel banks. The CCGW provides analog call detection, vocoding and devocoding of audio, station keying and dekeying through Tone Remote Control (TRC) or E&M relay, and tone LOBL (Line Operated Busy Light) detection (for parallel console interoperation).
CSC	Conventional Site Controller	A GCP 8000 site controller with conventional software, which provides a way for console and radio users at the MCC 7500 Dispatch Console site to maintain communications over conventional resources local to that site when the console site is unable to maintain wide area operation.
CSMS	Core Security Management Server	A virtual machine that functions as a management entity for network security in an ASTRO® 25 system. The CSMS manages the components in the Network Interface Barrier (NIB) and is equipped with anti-malware management software and, optionally, remote user authentication management software.
DAS	Direct Attached Storage	A data storage device or system (e.g. an enclosure holding a number of hard disk drives) attached "directly" (without a network device) to a server or workstation. Provides the storage needs of the VMS servers
DC	Domain Controller	A Motorola radio system's network management subsystem contains Domain Controllers, which provide Domain Name Services (DNS), Active Directory, and RADIUS services to all supported devices in the ASTRO® 25 system. Domain Controllers are also referred to as Authentication Servers because they provide authentication services.
FW	Firewall	A network security device providing network boundary enforcement and attack detection features.
GMC	Graphical Master Computer	MOSCAD Client used to view MOSCAD application
GWS	Graphical Workstation	MOSCAD Server aggregating and managing MOSCAD data
LBS	NICE Logging Backup Server	A server that archives IP log files from the Logger and SQL database information related to IP logfiles
NAS	Network Attached Storage	A data storage device attached to the network to store date from the BAR application
NMC	Network Management Client	The Network Management Client is a Windows based PC running the various network management client applications accessing the network management servers
None	NICE IP Logger	A logger that records IP voicepaths or Talkgroups in the Radio Network Infrastructure (RNI).
None	Terminal Server	Hardware that provides serial access to Network Management (NM) servers and network transport equipment in the zone. The terminal server has a separate direct RS-232 connection to each of its supported devices. When used to support remote analog access, the terminal server is often referred to as the Remote Access Server (RAS) or Analog Remote Access (ARA) server . When used to support out-ofband management, the terminal server is often referred to as the Out-of-Band management server.
None	TRAK	A system providing ultrastable frequency time and reference signals, referenced to the GPS satellite system.



MOTOROLA

PROJECT:

FLUVANNA COUNTY, VA

TITLE:

ACRONYMS AND DEFINITIONS P. 1

DESIGNED BY:

MATTHEW TELEP

DATE:

11/03/2015

Acronym	Name	Definition
4W	4 Wire E&M	4-wire (2-pair) transmission path for the voice signal.
ACIM	Astro Control Interface Module	The ASTRO Control Interface Module (ACIM) feature adds the serial control protocol to the GGM 8000 to allow exchanging control information between an MCC 7500 console and a Motorola consolette.
Acronym	Name	Definition
4W	4 Wire E&M	4-wire (2-pair) transmission path for the voice signal.
ACIM	Astro Control Interface Module	The ASTRO Control Interface Module (ACIM) feature adds the serial control protocol to the GGM 8000 to allow exchanging control information between an MCC 7500 console and a Motorola consolette.
Acronym	Name	Definition
4W	4 Wire E&M	4-wire (2-pair) transmission path for the voice signal.
ACIM	Astro Control Interface Module	The ASTRO Control Interface Module (ACIM) feature adds the serial control protocol to the GGM 8000 to allow exchanging control information between an MCC 7500 console and a Motorola consolette.
Acronym	Name	Definition
4W	4 Wire E&M	4-wire (2-pair) transmission path for the voice signal.
ACIM	Astro Control Interface Module	The ASTRO Control Interface Module (ACIM) feature adds the serial control protocol to the GGM 8000 to allow exchanging control information between an MCC 7500 console and a Motorola consolette.
Acronym	Name	Definition
4W	4 Wire E&M	4-wire (2-pair) transmission path for the voice signal.
ACIM	Astro Control Interface Module	The ASTRO Control Interface Module (ACIM) feature adds the serial control protocol to the GGM 8000 to allow exchanging control information between an MCC 7500 console and a Motorola consolette.

 MOTOROLA	
PROJECT: FLUVANNA COUNTY, VA	
TITLE: ACRONYMS AND DEFINITIONS P. 2	
DESIGNED BY: MATTHEW TELEP	DATE: 11/03/2015

APPENDIX B - L2 Core Master Site Inventory

QTY	NOMENCLATURE	DESCRIPTION
1	SQM01SUM0274	SINGLE ZONE TRUNKED L CORE
1	CA02882AA	ADD: REDUNDANT CORE
1	CA01663AB	ADD: RACK
1	UA00137AA	ADD: EMAIL ALARM NOTIFICATIONS
1	CA01750AA	ADD: TERMINAL SERVER
1	CA02635AA	ADD: Fortinet Firewall Appliance
7	UA00159AA	ADD: P25 PHASE 2 TDMA TRKNG OP SITE LIC
21	UA00161AA	ADD: P25 PHASE 2 TDMA SW BASE RADIO LIC
13	CA02193AA	ADD: ANTI-MALWARE DEF UPDATE LIC
1	UA00163AA	ADD: INTERSYSTEM DATA - CONNECTED CEN
1	CLN1856	2620-24 ETHERNET SWITCH
4	T7885	MCAFFEE WINDOWS AV CLIENT
1	T7537	KVL 4000 KEYLOADER
1	U239AD	ADD: ASTRO 25 MODE
1	X795AJ	ADD: ASN MODE
1	CA01598AA	ADD: AC LINE CORD US
1	C793BM	ADD: ADD: DVI-XL ENCRYPTION SOFTWARE
1	CA00182AP	ADD: AES ENCRYPTION SOFTWARE
1	X423AF	ADD: DES/DES-XL/DES-OFB ENCRYPTION
1	C543	ADD: CABLE FOR RNC, DIU, MGEG
1	C724	CABLE, KEYLOAD
1	CA01603AA	ADD: USB COMM/CHARGE CABLE W/ CUP
1	HKN6182	KEYLOADING CABLE ADAPTER (GCAI)
1	TDN9390	KVL CABLE FOR XTS3000 AND MTS2000
1	TKN8209	CABLE KEYLOAD MX
1	DVN4046B	MASTER SYSTEM KEY STARTER KIT
2	DLN6975	FRE: DL380 G9 HC 900 GB DISK
1	DLN6972	FRU: DL380 G9 POWER SUPPLY
2	DLN6970	FRU: DL380 G9 HARD DRIVE
2	DLN6971	FRU: DL380 G9 DVD DRIVE
1	DLN6976	FRE: DL380 G9 HC 600 GB DISK
1	DLN6880	DAS - CHASSIS ONLY
2	DLN6978	FRU: DOTHILL 4524 RAID I/O CONTROLLER MODULE
2	DLN6867	DAS POWER SUPPLY
4	CKN6967	CABLE, DATA,MINI-SAS TO MINI-SAS HD, LENGTH 1M
1	SQM01SUM0205	GGM 8000 GATEWAY
1	CA01619AA	ADD: DC POWER
1	CLN1856	2620-24 ETHERNET SWITCH
1	T7321	GCM 8000 COMPARATOR
2	CA01183AA	ADD: GCM 8000 COMPARATOR
2	CA01185AA	ADD: IP BASED MULTISITE OPERATION

QTY	NOMENCLATURE	DESCRIPTION
2	CA01901AA	ADD: P25 TDMA COMPARATOR SOFTWARE
1	X153AW	ADD: RACK MOUNT HARDWARE
1	T7321	GCM 8000 COMPARATOR
2	CA01183AA	ADD: GCM 8000 COMPARATOR
2	CA01185AA	ADD: IP BASED MULTISITE OPERATION
2	CA01901AA	ADD: P25 TDMA COMPARATOR SOFTWARE
1	X153AW	ADD: RACK MOUNT HARDWARE
1	T7038	GCP 8000 SITE CONTROLLER
1	CA00303AA	ADD: QTY (1) SITE CONTROLLER
7	CA02214AA	ADD: SIMULCAST REMOTE SITE LICENSE VOICE ONLY
1	CA01194AA	ADD: IP BASED MULTISITE SITE CONTROLLER SOFTWARE
1	X153AW	ADD: RACK MOUNT HARDWARE
1	T7038	GCP 8000 SITE CONTROLLER
1	CA00303AA	ADD: QTY (1) SITE CONTROLLER
7	CA02214AA	ADD: SIMULCAST REMOTE SITE LICENSE VOICE ONLY
1	CA01194AA	ADD: IP BASED MULTISITE SITE CONTROLLER SOFTWARE
1	X153AW	ADD: RACK MOUNT HARDWARE
1	DSTRAK91008E	PRIME/MASTER SITE REDUNDANT MODULAR FREQUENCY TIMING SYSTEM AC
50	L1700	FSJ1-50A CABLE: 1/4" SUPERFLEX POLY JKT PER FOOT
4	DDN9769	F1TNM-HC 1/4" TYPE N MALE CONNECTOR FOR FSJ1-50A CABLE
2	SQM01SUM0205	GGM 8000 GATEWAY
2	CA01616AA	ADD: AC POWER
2	SQM01SUM0205	GGM 8000 GATEWAY
2	CA01616AA	ADD: AC POWER
2	CLN1859	2620-48 ETHERNET SWITCH
2	TRN7343	SEVEN AND A HALF FOOT RACK
1	NPI_000005	Microwave Hop Estimate
1	DSTRAK91061	FOUR PORT DDM
1	SQM01SUM0205	GGM 8000 GATEWAY
1	CA01616AA	ADD: AC POWER
1	CLN1856	2620-24 ETHERNET SWITCH
1	DLN6892	FRU: XCVR VHF V2
1	DLN6897	FRU: PA VHF
1	DLN6569	FRU: GCP 8000/GCM 8000
1	DLN6781	FRU: POWER SUPPLY
1	DLN6455	CONFIGURATION/SERVICE SOFTWARE
1	DLN6793B	FRU: PWR EFF POWER SUPPLY AC/48VDC
1	DLN6898	FRU: FAN MODULE
1	DLN6821	FRU: GTR ANALOG 4W E&M SIMULCST KIT
1	DLN6709	GTR/GPW OPTION CARD
1	DLN6794	FRU: PWR EFF OPTION CARD
2	SQM01SUM0205	GGM 8000 GATEWAY
2	CA01616AA	ADD: AC POWER

QTY	NOMENCLATURE	DESCRIPTION
2	CLN1856	2620-24 ETHERNET SWITCH
1	SQM01SUM7054	GTR 8000 EXPANDABLE SITE SUBSYSTEM
1	X530BG	ADD: VHF (136-174 MHZ)
3	CA01842AA	ADD: P25 TDMA SOFTWARE
1	X304AE	ADD: QTY (4) GTR 8000 BASE RADIOS
4	CA01193AA	ADD: IP BASED MULTISITE BASE RADIO SOFTWARE
2	CA00884AA	ADD: QTY (1) XHUB
1	CA01953AA	ADD: POWER EFFICIENCY PACKAGE
1	X882AH	ADD: 7.5 FT OPEN RACK, 48RU
1	CA02684AA	ADD: AC ONLY POWER DISTRIBUTION
6	DS3500072	NEMA 5-20 TO IEC C15 CORD, 10 FT FOR GTR RACKS
1	TRN7343	SEVEN AND A HALF FOOT RACK
1	NPI_000005	Microwave Hop Estimate
1	NPI_000003	PLACEHOLDER Multicoupler, VHF custom 8 port
1	NPI_000001	PLACEHOLDER Combiner, VHF custom 4 port
1	DLN6455	CONFIGURATION/SERVICE SOFTWARE
2	SQM01SUM0205	GGM 8000 GATEWAY
2	CA01616AA	ADD: AC POWER
2	CLN1856	2620-24 ETHERNET SWITCH
1	DSTRAK91009E	REMOTE SITE REDUNDANT MODULAR FREQUENCY TIMING SYSTEM AC
1	DSTRAK91071	FOUR PORT IRIG B TIME CODE FDM
1	DSTRAK91061	FOUR PORT DDM
50	L1700	FSJ1-50A CABLE: 1/4" SUPERFLEX POLY JKT PER FOOT
4	DDN9769	F1TNM-HC 1/4" TYPE N MALE CONNECTOR FOR FSJ1-50A CABLE
1	SQM01SUM7054	GTR 8000 EXPANDABLE SITE SUBSYSTEM
1	X530BG	ADD: VHF (136-174 MHZ)
3	CA01842AA	ADD: P25 TDMA SOFTWARE
1	X304AE	ADD: QTY (4) GTR 8000 BASE RADIOS
4	CA01193AA	ADD: IP BASED MULTISITE BASE RADIO SOFTWARE
2	CA00884AA	ADD: QTY (1) XHUB
1	CA01953AA	ADD: POWER EFFICIENCY PACKAGE
1	X882AH	ADD: 7.5 FT OPEN RACK, 48RU
1	CA02684AA	ADD: AC ONLY POWER DISTRIBUTION
6	DS3500072	NEMA 5-20 TO IEC C15 CORD, 10 FT FOR GTR RACKS
2	TRN7343	SEVEN AND A HALF FOOT RACK
1	NPI_000005	Microwave Hop Estimate
1	NPI_000003	PLACEHOLDER Multicoupler, VHF custom 8 port
1	NPI_000001	PLACEHOLDER Combiner, VHF custom 4 port
1	DLN6455	CONFIGURATION/SERVICE SOFTWARE
2	SQM01SUM0205	GGM 8000 GATEWAY
2	CA01616AA	ADD: AC POWER
2	CLN1856	2620-24 ETHERNET SWITCH
1	DSTRAK91009E	REMOTE SITE REDUNDANT MODULAR FREQUENCY TIMING SYSTEM AC

QTY	NOMENCLATURE	DESCRIPTION
1	DSTRAK91071	FOUR PORT IRIG B TIME CODE FDM
1	DSTRAK91061	FOUR PORT DDM
50	L1700	FSJ1-50A CABLE: 1/4" SUPERFLEX POLY JKT PER FOOT
4	DDN9769	F1TNM-HC 1/4" TYPE N MALE CONNECTOR FOR FSJ1-50A CABLE
1	SQM01SUM7054	GTR 8000 EXPANDABLE SITE SUBSYSTEM
1	X530BG	ADD: VHF (136-174 MHZ)
3	CA01842AA	ADD: P25 TDMA SOFTWARE
1	X304AE	ADD: QTY (4) GTR 8000 BASE RADIOS
4	CA01193AA	ADD: IP BASED MULTISITE BASE RADIO SOFTWARE
2	CA00884AA	ADD: QTY (1) XHUB
1	CA01953AA	ADD: POWER EFFICIENCY PACKAGE
1	X882AH	ADD: 7.5 FT OPEN RACK, 48RU
1	CA02684AA	ADD: AC ONLY POWER DISTRIBUTION
6	DS3500072	NEMA 5-20 TO IEC C15 CORD, 10 FT FOR GTR RACKS
2	TRN7343	SEVEN AND A HALF FOOT RACK
1	NPI_000005	Microwave Hop Estimate
1	NPI_000003	PLACEHOLDER Multicoupler, VHF custom 8 port
1	NPI_000001	PLACEHOLDER Combiner, VHF custom 4 port
1	DLN6455	CONFIGURATION/SERVICE SOFTWARE
2	SQM01SUM0205	GGM 8000 GATEWAY
2	CA01616AA	ADD: AC POWER
2	CLN1856	2620-24 ETHERNET SWITCH
1	DSTRAK91009E	REMOTE SITE REDUNDANT MODULAR FREQUENCY TIMING SYSTEM AC
1	DSTRAK91071	FOUR PORT IRIG B TIME CODE FDM
1	DSTRAK91061	FOUR PORT DDM
50	L1700	FSJ1-50A CABLE: 1/4" SUPERFLEX POLY JKT PER FOOT
4	DDN9769	F1TNM-HC 1/4" TYPE N MALE CONNECTOR FOR FSJ1-50A CABLE
1	SQM01SUM7054	GTR 8000 EXPANDABLE SITE SUBSYSTEM
1	X530BG	ADD: VHF (136-174 MHZ)
3	CA01842AA	ADD: P25 TDMA SOFTWARE
1	X304AE	ADD: QTY (4) GTR 8000 BASE RADIOS
4	CA01193AA	ADD: IP BASED MULTISITE BASE RADIO SOFTWARE
2	CA00884AA	ADD: QTY (1) XHUB
1	CA01953AA	ADD: POWER EFFICIENCY PACKAGE
1	X882AH	ADD: 7.5 FT OPEN RACK, 48RU
1	CA02684AA	ADD: AC ONLY POWER DISTRIBUTION
6	DS3500072	NEMA 5-20 TO IEC C15 CORD, 10 FT FOR GTR RACKS
2	TRN7343	SEVEN AND A HALF FOOT RACK
1	NPI_000005	Microwave Hop Estimate
1	NPI_000003	PLACEHOLDER Multicoupler, VHF custom 8 port
1	NPI_000001	PLACEHOLDER Combiner, VHF custom 4 port
1	DLN6455	CONFIGURATION/SERVICE SOFTWARE
2	SQM01SUM0205	GGM 8000 GATEWAY

QTY	NOMENCLATURE	DESCRIPTION
2	CA01616AA	ADD: AC POWER
2	CLN1856	2620-24 ETHERNET SWITCH
1	DSTRAK91009E	REMOTE SITE REDUNDANT MODULAR FREQUENCY TIMING SYSTEM AC
1	DSTRAK91071	FOUR PORT IRIG B TIME CODE FDM
1	DSTRAK91061	FOUR PORT DDM
50	L1700	FSJ1-50A CABLE: 1/4" SUPERFLEX POLY JKT PER FOOT
4	DDN9769	F1TNM-HC 1/4" TYPE N MALE CONNECTOR FOR FSJ1-50A CABLE
1	SQM01SUM7054	GTR 8000 EXPANDABLE SITE SUBSYSTEM
1	X530BG	ADD: VHF (136-174 MHZ)
3	CA01842AA	ADD: P25 TDMA SOFTWARE
1	X304AE	ADD: QTY (4) GTR 8000 BASE RADIOS
4	CA01193AA	ADD: IP BASED MULTISITE BASE RADIO SOFTWARE
2	CA00884AA	ADD: QTY (1) XHUB
1	CA01953AA	ADD: POWER EFFICIENCY PACKAGE
1	X882AH	ADD: 7.5 FT OPEN RACK, 48RU
1	CA02684AA	ADD: AC ONLY POWER DISTRIBUTION
6	DS3500072	NEMA 5-20 TO IEC C15 CORD, 10 FT FOR GTR RACKS
2	TRN7343	SEVEN AND A HALF FOOT RACK
1	NPI_000005	Microwave Hop Estimate
1	NPI_000003	PLACEHOLDER Multicoupler, VHF custom 8 port
1	NPI_000001	PLACEHOLDER Combiner, VHF custom 4 port
1	DLN6455	CONFIGURATION/SERVICE SOFTWARE
2	SQM01SUM0205	GGM 8000 GATEWAY
2	CA01616AA	ADD: AC POWER
2	CLN1856	2620-24 ETHERNET SWITCH
1	DSTRAK91009E	REMOTE SITE REDUNDANT MODULAR FREQUENCY TIMING SYSTEM AC
1	DSTRAK91071	FOUR PORT IRIG B TIME CODE FDM
1	DSTRAK91061	FOUR PORT DDM
50	L1700	FSJ1-50A CABLE: 1/4" SUPERFLEX POLY JKT PER FOOT
4	DDN9769	F1TNM-HC 1/4" TYPE N MALE CONNECTOR FOR FSJ1-50A CABLE
1	SQM01SUM7054	GTR 8000 EXPANDABLE SITE SUBSYSTEM
1	X530BG	ADD: VHF (136-174 MHZ)
3	CA01842AA	ADD: P25 TDMA SOFTWARE
1	X304AE	ADD: QTY (4) GTR 8000 BASE RADIOS
4	CA01193AA	ADD: IP BASED MULTISITE BASE RADIO SOFTWARE
2	CA00884AA	ADD: QTY (1) XHUB
1	CA01953AA	ADD: POWER EFFICIENCY PACKAGE
1	X882AH	ADD: 7.5 FT OPEN RACK, 48RU
1	CA02684AA	ADD: AC ONLY POWER DISTRIBUTION
6	DS3500072	NEMA 5-20 TO IEC C15 CORD, 10 FT FOR GTR RACKS
2	TRN7343	SEVEN AND A HALF FOOT RACK
1	NPI_000005	Microwave Hop Estimate
1	NPI_000003	PLACEHOLDER Multicoupler, VHF custom 8 port

QTY	NOMENCLATURE	DESCRIPTION
1	NPI_000001	PLACEHOLDER Combiner, VHF custom 4 port
1	DLN6455	CONFIGURATION/SERVICE SOFTWARE
2	SQM01SUM0205	GGM 8000 GATEWAY
2	CA01616AA	ADD: AC POWER
2	CLN1856	2620-24 ETHERNET SWITCH
1	DSTRAK91009E	REMOTE SITE REDUNDANT MODULAR FREQUENCY TIMING SYSTEM AC
1	DSTRAK91071	FOUR PORT IRIG B TIME CODE FDM
1	DSTRAK91061	FOUR PORT DDM
50	L1700	FSJ1-50A CABLE: 1/4" SUPERFLEX POLY JKT PER FOOT
4	DDN9769	F1TNM-HC 1/4" TYPE N MALE CONNECTOR FOR FSJ1-50A CABLE
1	SQM01SUM7054	GTR 8000 EXPANDABLE SITE SUBSYSTEM
1	X530BG	ADD: VHF (136-174 MHZ)
3	CA01842AA	ADD: P25 TDMA SOFTWARE
1	X304AE	ADD: QTY (4) GTR 8000 BASE RADIOS
4	CA01193AA	ADD: IP BASED MULTISITE BASE RADIO SOFTWARE
2	CA00884AA	ADD: QTY (1) XHUB
1	CA01953AA	ADD: POWER EFFICIENCY PACKAGE
1	X882AH	ADD: 7.5 FT OPEN RACK, 48RU
1	CA02684AA	ADD: AC ONLY POWER DISTRIBUTION
6	DS3500072	NEMA 5-20 TO IEC C15 CORD, 10 FT FOR GTR RACKS
2	TRN7343	SEVEN AND A HALF FOOT RACK
1	NPI_000005	Microwave Hop Estimate
1	NPI_000003	PLACEHOLDER Multicoupler, VHF custom 8 port
1	NPI_000001	PLACEHOLDER Combiner, VHF custom 4 port
1	DLN6455	CONFIGURATION/SERVICE SOFTWARE



Motorola Solutions, Inc.
809 Pinnacle Drive
Suite G
Linthicum, MD 21090

Telephone: +1 410 712 6200
Fax: +1 410 712 6489

December 5, 2017

Mr. Michael Grandstaff
ECC Director
Fluvanna County
160 Commons Boulevard
Palmyra, VA 22963

Re: Fluvanna County's Core (Master Site)

Dear Mr. Grandstaff:

Per our discussion on Tuesday, December 5, I will describe Louisa County's use of the Core currently located at the Fluvanna County Sheriff's Office. Fluvanna County will not have to make any adjustments or purchase any additional equipment in order to bring Louisa County onto its Core. At a high level, Louisa County has purchased a microwave hop (link) between the CVEC site and the Zion Crossroads site. This will allow Louisa County to connect their Prime Site, Dispatch Consoles and RF sites to the Core. Both the Fluvanna County and Louisa County remain autonomous.

A benefit derived by operating as a regional system is that each County is able to utilize the others coverage footprint without changing a channel/knob on the radio. In addition, if the Core is inoperable or either County loses connectivity to the Core they will remain in "Site Trunking" essentially little to no change to the system operation for the end users.

Louisa County will have its own Unified Event Manager (UEM) terminal and Remote Terminal User's (RTU's) for alarm and control functionality at its sites. A Provisioning Manager terminal has been purchased to allow Louisa to make adjustments to their fleet without infringing on Fluvanna County. A Zone Watch and Historical terminal will provide Louisa County with critical system information.

An attachment has been provided that shows the equipment list breakdown and selling price of the Core sold to Fluvanna County. As Motorola, implements and builds out the Louisa County system, we are contractually obligated to provide system documentation which will include a shared system diagram and tower/antenna location diagram. These items will be provided as completed.

If you have any questions/concerns, please contact me at C-(804) 370-6247.

Sincerely,

Steve R. Garner

Motorola Solutions, Inc.
Steve R. Garner
Senior Account Manager



Motorola Solutions, Inc.
809 Pinnacle Drive
Suite G
Linthicum, MD 21090

Telephone: +1 410 712 6200
Fax: +1 410 712 6489

EQUIPMENT LIST--CORE	CONTRACT PRICE
MNC Servers	\$ 197,391.00
Networking/Routing/Switching Equipment	\$ 31,030.10
Network Security and AntiVirus Protections	\$ 6,443.25
NMS/Fault Management	\$ 126,333.10
Network Management System Clients/Printers	\$ 15,953.00
NMS Software Applications	\$ 595.00
Key Management Facility/Key Fill	\$ 5,392.91
P25 Comparators/Audio Distribution	\$ 90,480.00
Timing/Frequency Reference	\$ 28,165.16
Rack/Cabinet	\$ 420.75
Grounding/Suppression	\$ 822.80
Software/Firmware Licenses	\$ 148,500.00
Programming Software, Cables and Interface Equipment	\$ 850.00
Spare Equipment	\$ 109,001.00
TOTAL PRICE FOR CORE	\$ 761,378.07

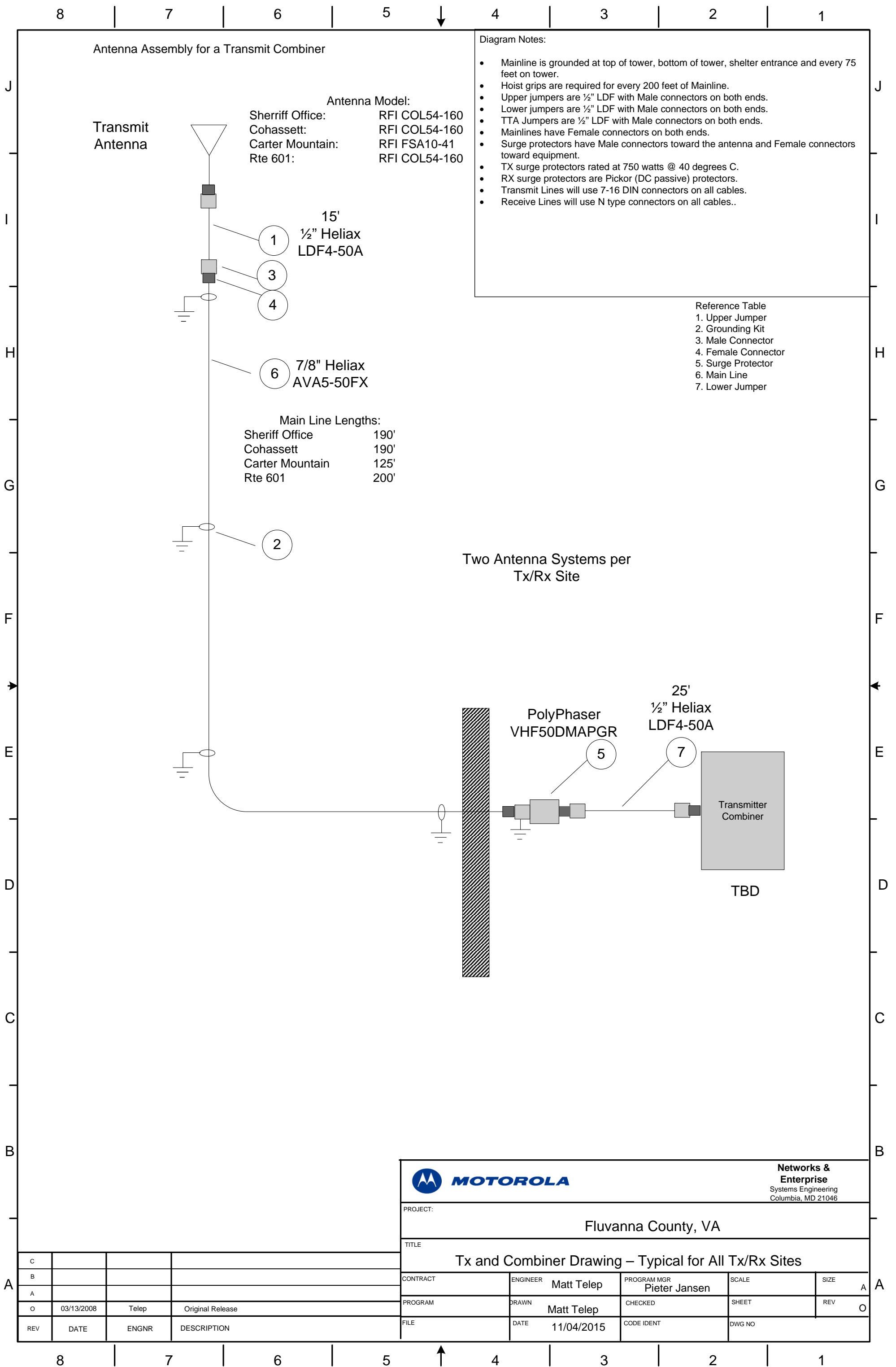

C			
B			
A			
O	03/13/2008	Telep	Original Release
REV	DATE	ENGR	DESCRIPTION

		Networks & Enterprise Systems Engineering Columbia, MD 21046	
PROJECT: Fluvanna County, VA			
TITLE: Tx and Combiner Drawing – Typical for All Tx/Rx Sites			
CONTRACT	ENGINEER: Matt Telep	PROGRAM MGR: Pieter Jansen	SCALE: A
PROGRAM	DRAWN: Matt Telep	CHECKED:	SHEET: O
FILE	DATE: 11/04/2015	CODE IDENT:	DWG NO:

8 | 7 | 6 | 5 | 4 | 3 | 2 | 1

Antenna Assembly for a Receiver Multicoupler
without a Tower Top Amplifier

- Diagram Notes:
- Mainline is grounded at top of tower, bottom of tower, shelter entrance and every 75 feet on tower.
 - Hoist grips are required for every 200 feet of Mainline.
 - Upper jumpers are 1/2" LDF with Male connectors on both ends.
 - Lower jumpers are 1/2" Superflex with Male connectors on both ends.
 - TTA Jumpers, when required, are 1/2" LDF with Male connectors on both ends.
 - Mainlines have Female connectors on both ends.
 - Surge protectors have Male connectors toward the antenna and Female connectors toward equipment.
 - TX surge protectors rated at 750 watts @ 40 degrees C.
 - RX surge protectors are Pickor (DC passive) protectors.
 - Transmit Lines will use 7-16 DIN connectors on all cables.
 - Receive Lines will use N type connectors on all cables.
 - Transmitter Combiners, Receiver Multicouplers and TTAs are not included as part of the Antenna Assembly equipment.

Antenna Model:

Sherriff Office:	RFI COL54-160
Cohassett:	RFI COL54-160
Carter Mountain:	RFI FSA10-41
Rte 601:	RFI COL54-160
Bremo:	RFI COL54-160
VFW:	RFI COL54-160
Rte 656:	RFI COL54-160

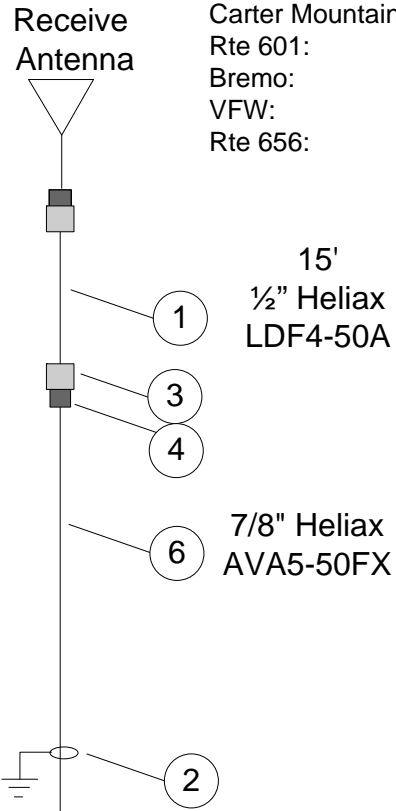

Main Line Lengths:

Sheriff Office	230'
Cohassett	230'
Carter Mountain	150'
Rte 601	240'
Bremo	195'
VFW	240'
Rte 656	240'

Reference Table

1. Upper Jumper
2. Grounding Kit
3. Male Connector
4. Female Connector
5. Surge Protector
6. Main Line
7. Lower Jumper

One Antenna Systems per
Rx Only Site

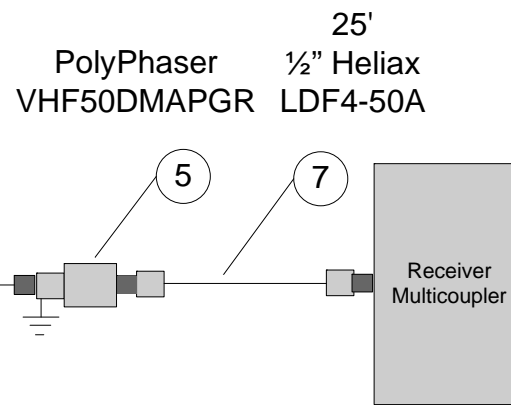

		Networks & Enterprise Systems Engineering Columbia, MD 21046	
PROJECT: Fluvanna County, VA			
TITLE: Rx Drawing – Typical for All Tx/Rx and Rx Only Sites			
CONTRACT	ENGINEER: Matt Telep	PROGRAM MGR: Pieter Jansen	SCALE
PROGRAM	DRAWN: Matt Telep	CHECKED	SHEET
FILE	DATE: 11/04/2015	CODE IDENT	DWG NO

C			
B			
A			
O	11/04/2015	Telep	Original Release
REV	DATE	ENGNR	DESCRIPTION

8 | 7 | 6 | 5 | 4 | 3 | 2 | 1

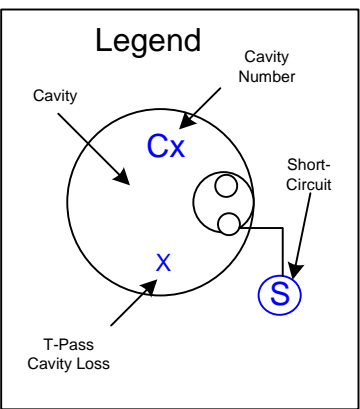
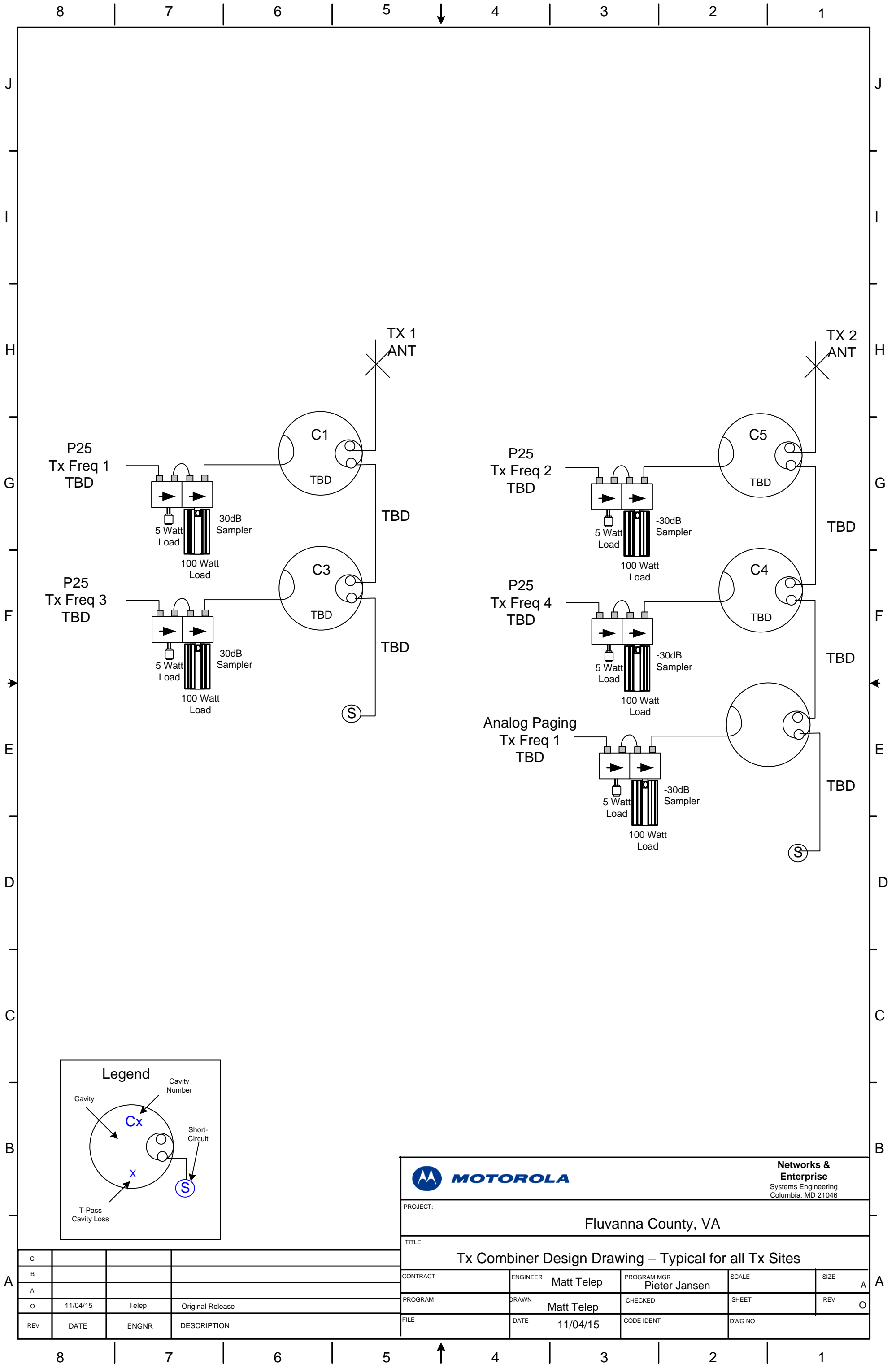

		Networks & Enterprise Systems Engineering Columbia, MD 21046		
PROJECT: Fluvanna County, VA				
TITLE: Tx Combiner Design Drawing – Typical for all Tx Sites				
CONTRACT	ENGINEER: Matt Telep	PROGRAM MGR: Pieter Jansen	SCALE	SIZE: A
PROGRAM	DRAWN: Matt Telep	CHECKED	SHEET	REV: O
FILE	DATE: 11/04/15	CODE IDENT	DWG NO	

C			
B			
A			
O	11/04/15	Telep	Original Release
REV	DATE	ENGR	DESCRIPTION

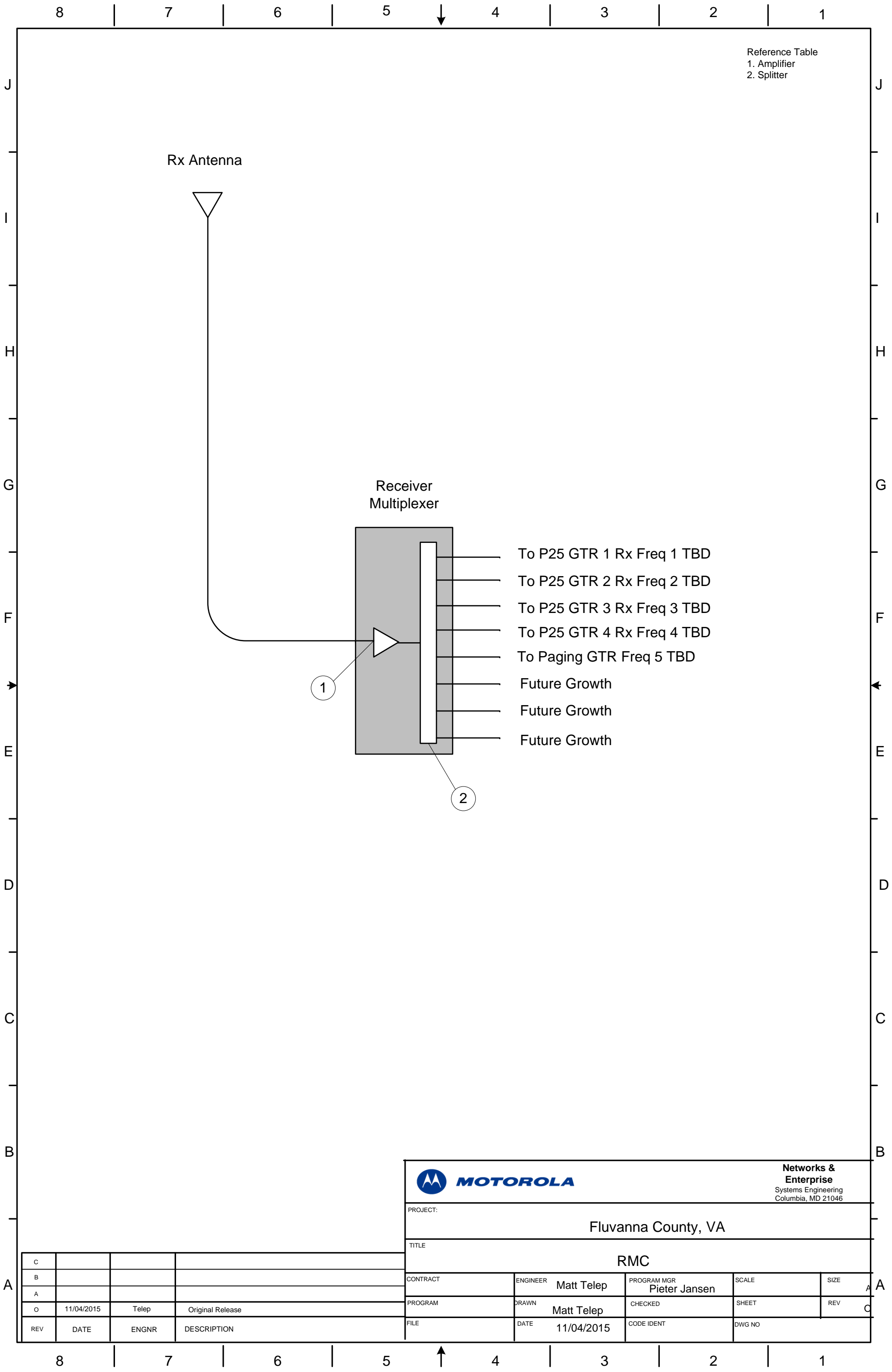

Reference Table
 1. Amplifier
 2. Splitter

Rx Antenna

Receiver Multiplexer

- To P25 GTR 1 Rx Freq 1 TBD
- To P25 GTR 2 Rx Freq 2 TBD
- To P25 GTR 3 Rx Freq 3 TBD
- To P25 GTR 4 Rx Freq 4 TBD
- To Paging GTR Freq 5 TBD
- Future Growth
- Future Growth
- Future Growth

1

2

		Networks & Enterprise Systems Engineering Columbia, MD 21046		
		PROJECT: Fluvanna County, VA		
TITLE: RMC				
CONTRACT	ENGINEER: Matt Telep	PROGRAM MGR: Pieter Jansen	SCALE	SIZE
PROGRAM	DRAWN: Matt Telep	CHECKED	SHEET	REV
FILE	DATE: 11/04/2015	CODE IDENT	DWG NO	

C			
B			
A			
O	11/04/2015	Telep	Original Release
REV	DATE	ENGNR	DESCRIPTION

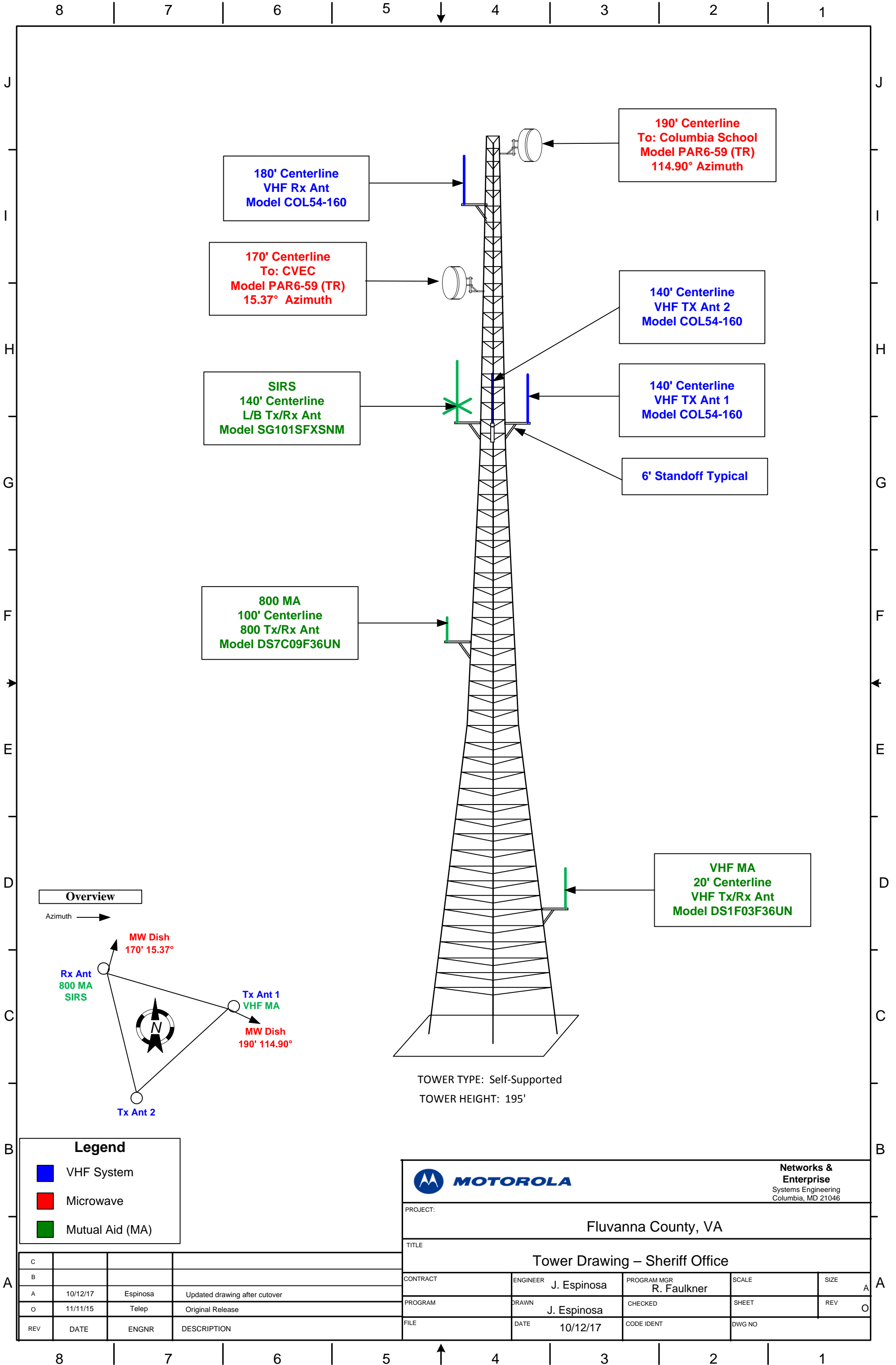

180' Centerline
VHF Rx Ant
Model COL54-160

170' Centerline
To: CVEC
Model PAR6-59 (TR)
15.37° Azimuth

SIRS
140' Centerline
L/B Tx/Rx Ant
Model SG101SFXSNM

800 MA
100' Centerline
800 Tx/Rx Ant
Model DS7C09F36UN

190' Centerline
To: Columbia School
Model PAR6-59 (TR)
114.90° Azimuth

140' Centerline
VHF TX Ant 2
Model COL54-160

140' Centerline
VHF TX Ant 1
Model COL54-160

6' Standoff Typical

VHF MA
20' Centerline
VHF Tx/Rx Ant
Model DS1F03F36UN

TOWER TYPE: Self-Supported
TOWER HEIGHT: 195'

Overview

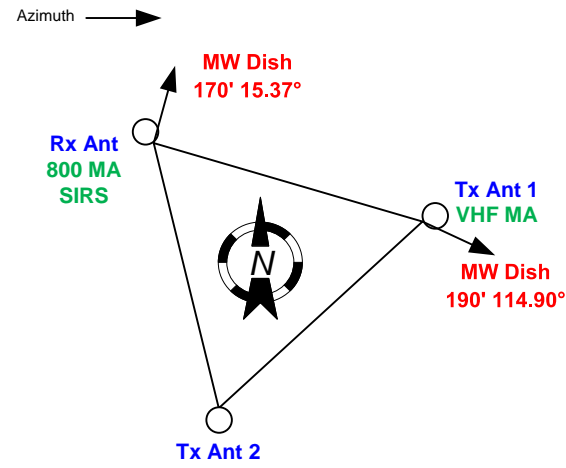



Legend

- VHF System
- Microwave
- Mutual Aid (MA)

		Networks & Enterprise Systems Engineering Columbia, MD 21046		
PROJECT: Fluvanna County, VA				
TITLE: Tower Drawing – Sheriff Office				
CONTRACT	ENGINEER	PROGRAM MGR	SCALE	SIZE
	J. Espinosa	R. Faulkner		A
PROGRAM	DRAWN	CHECKED	SHEET	REV
	J. Espinosa			O
FILE	DATE	CODE IDENT	DWG NO	
	10/12/17			

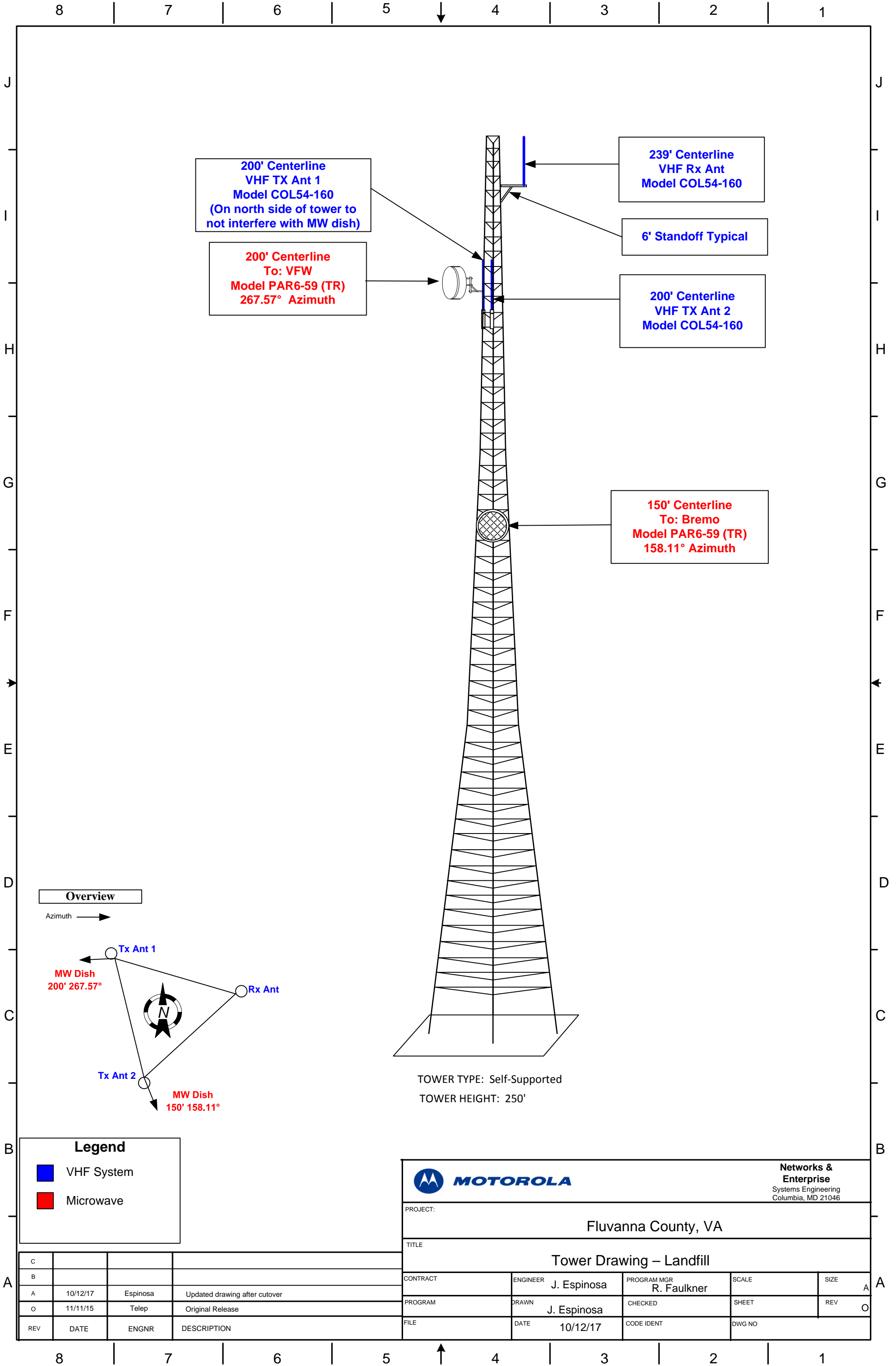
REV	DATE	ENGR	DESCRIPTION
C			
B			
A	10/12/17	Espinosa	Updated drawing after cutover
O	11/11/15	Telep	Original Release



 MOTOROLA		Networks & Enterprise Systems Engineering Columbia, MD 21046		
PROJECT: Fluvanna County, VA				
TITLE: Tower Drawing – Landfill				
CONTRACT	ENGINEER	PROGRAM MGR	SCALE	SIZE
	J. Espinosa	R. Faulkner		A
PROGRAM	DRAWN	CHECKED	SHEET	REV
	J. Espinosa			O
FILE	DATE	CODE IDENT	DWG NO	
	10/12/17			

REV	DATE	ENGR	DESCRIPTION
C			
B			
A	10/12/17	Espinosa	Updated drawing after cutover
O	11/11/15	Telep	Original Release

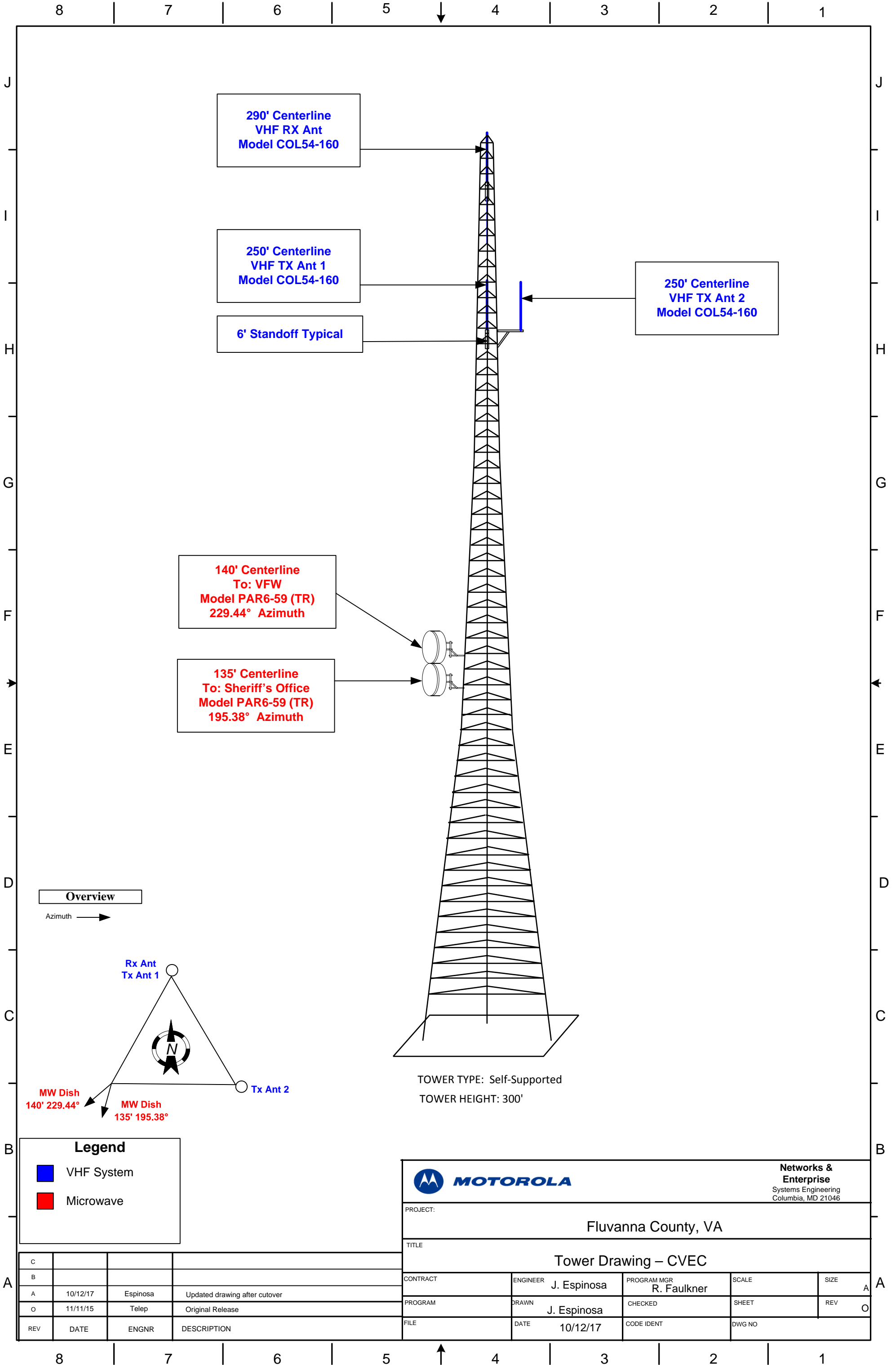

		Networks & Enterprise Systems Engineering Columbia, MD 21046	
TITLE: Tower Drawing – CVEC			
CONTRACT	ENGINEER: J. Espinosa	PROGRAM MGR: R. Faulkner	SCALE
PROGRAM	DRAWN: J. Espinosa	CHECKED	SHEET
FILE	DATE: 10/12/17	CODE IDENT	DWG NO

REV	DATE	ENGR	DESCRIPTION
C			
B			
A	10/12/17	Espinosa	Updated drawing after cutover
O	11/11/15	Telep	Original Release

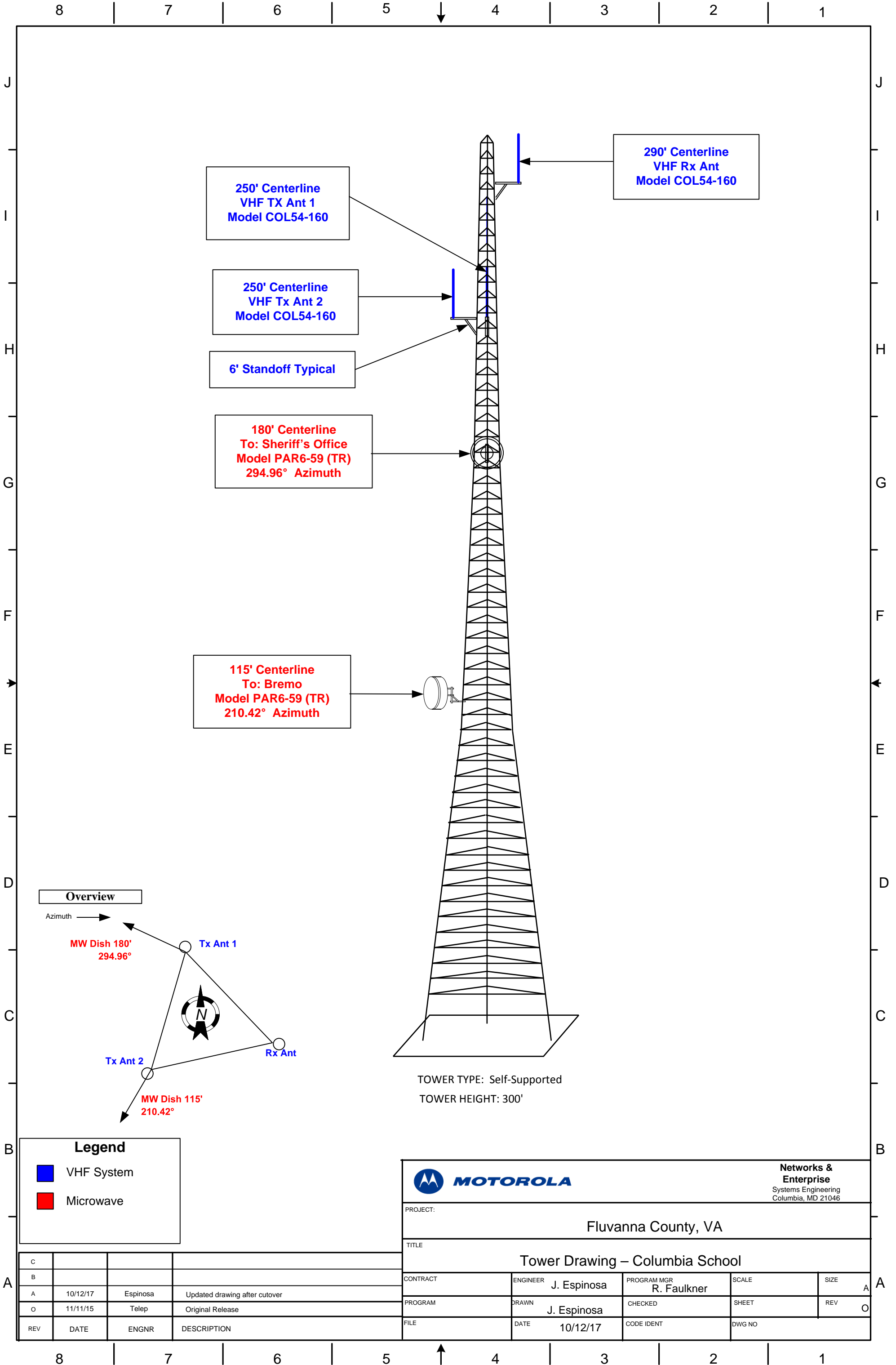

TOWER TYPE: Self-Supported
TOWER HEIGHT: 300'

Overview

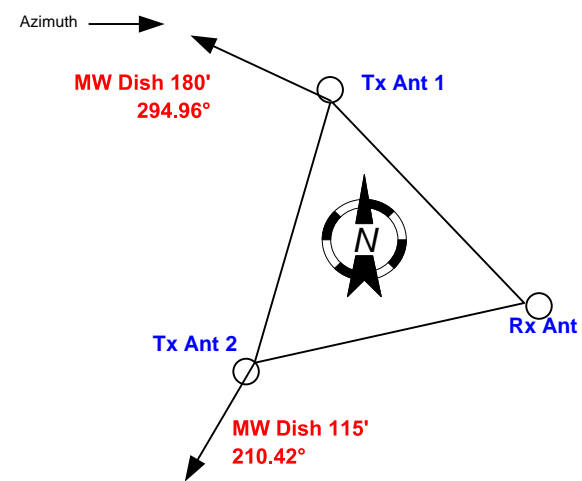

Legend

- VHF System
- Microwave

MOTOROLA Networks & Enterprise
Systems Engineering
Columbia, MD 21046

PROJECT: Fluvanna County, VA

TITLE: Tower Drawing – Columbia School

CONTRACT	ENGINEER J. Espinosa	PROGRAM MGR R. Faulkner	SCALE	SIZE A
----------	----------------------	-------------------------	-------	--------

PROGRAM	DRAWN J. Espinosa	CHECKED	SHEET	REV O
---------	-------------------	---------	-------	-------

FILE	DATE 10/12/17	CODE IDENT	DWG NO
------	---------------	------------	--------

REV	DATE	ENGR	DESCRIPTION
C			
B			
A	10/12/17	Espinosa	Updated drawing after cutover
O	11/11/15	Telep	Original Release

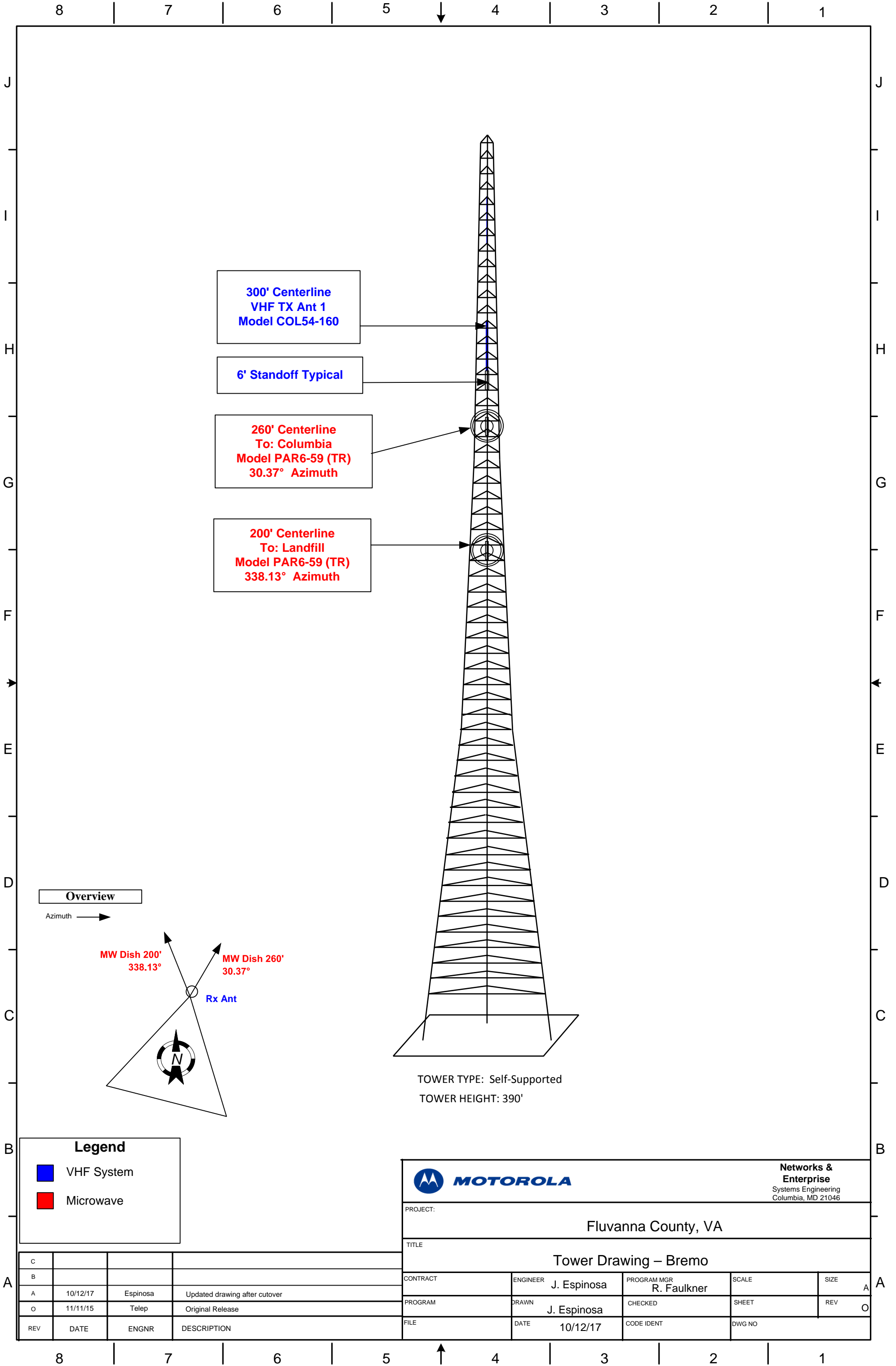

 MOTOROLA		Networks & Enterprise Systems Engineering Columbia, MD 21046		
PROJECT: Fluvanna County, VA				
TITLE: Tower Drawing – Bremo				
CONTRACT	ENGINEER	PROGRAM MGR	SCALE	SIZE
	J. Espinosa	R. Faulkner		A
PROGRAM	DRAWN	CHECKED	SHEET	REV
	J. Espinosa			O
FILE	DATE	CODE IDENT	DWG NO	
	10/12/17			

REV	DATE	ENGR	DESCRIPTION
C			
B			
A	10/12/17	Espinosa	Updated drawing after cutover
O	11/11/15	Telep	Original Release

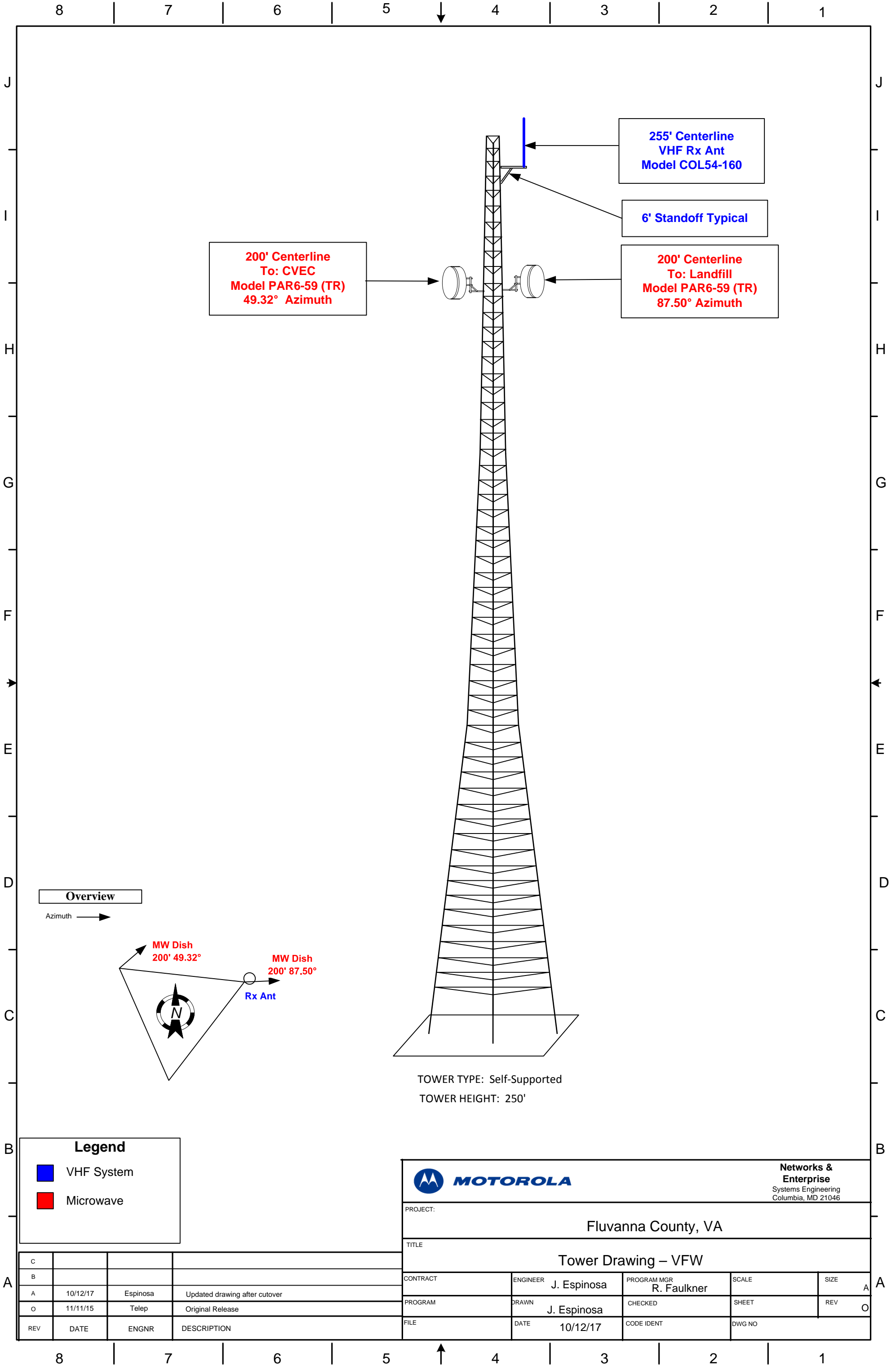

**200' Centerline
To: CVEC
Model PAR6-59 (TR)
49.32° Azimuth**

**255' Centerline
VHF Rx Ant
Model COL54-160**

6' Standoff Typical

**200' Centerline
To: Landfill
Model PAR6-59 (TR)
87.50° Azimuth**

Overview

Azimuth →

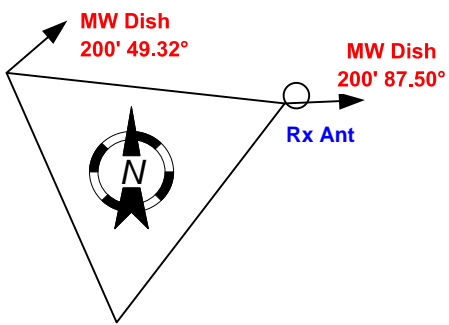

TOWER TYPE: Self-Supported
TOWER HEIGHT: 250'

Legend

- VHF System
- Microwave

 MOTOROLA		Networks & Enterprise Systems Engineering Columbia, MD 21046		
PROJECT: Fluvanna County, VA				
TITLE: Tower Drawing – VFW				
CONTRACT	ENGINEER	PROGRAM MGR	SCALE	SIZE
	J. Espinosa	R. Faulkner		A
PROGRAM	DRAWN	CHECKED	SHEET	REV
	J. Espinosa			O
FILE	DATE	CODE IDENT	DWG NO	
	10/12/17			

c			
B			
A	10/12/17	Espinosa	Updated drawing after cutover
O	11/11/15	Telep	Original Release
REV	DATE	ENGR	DESCRIPTION

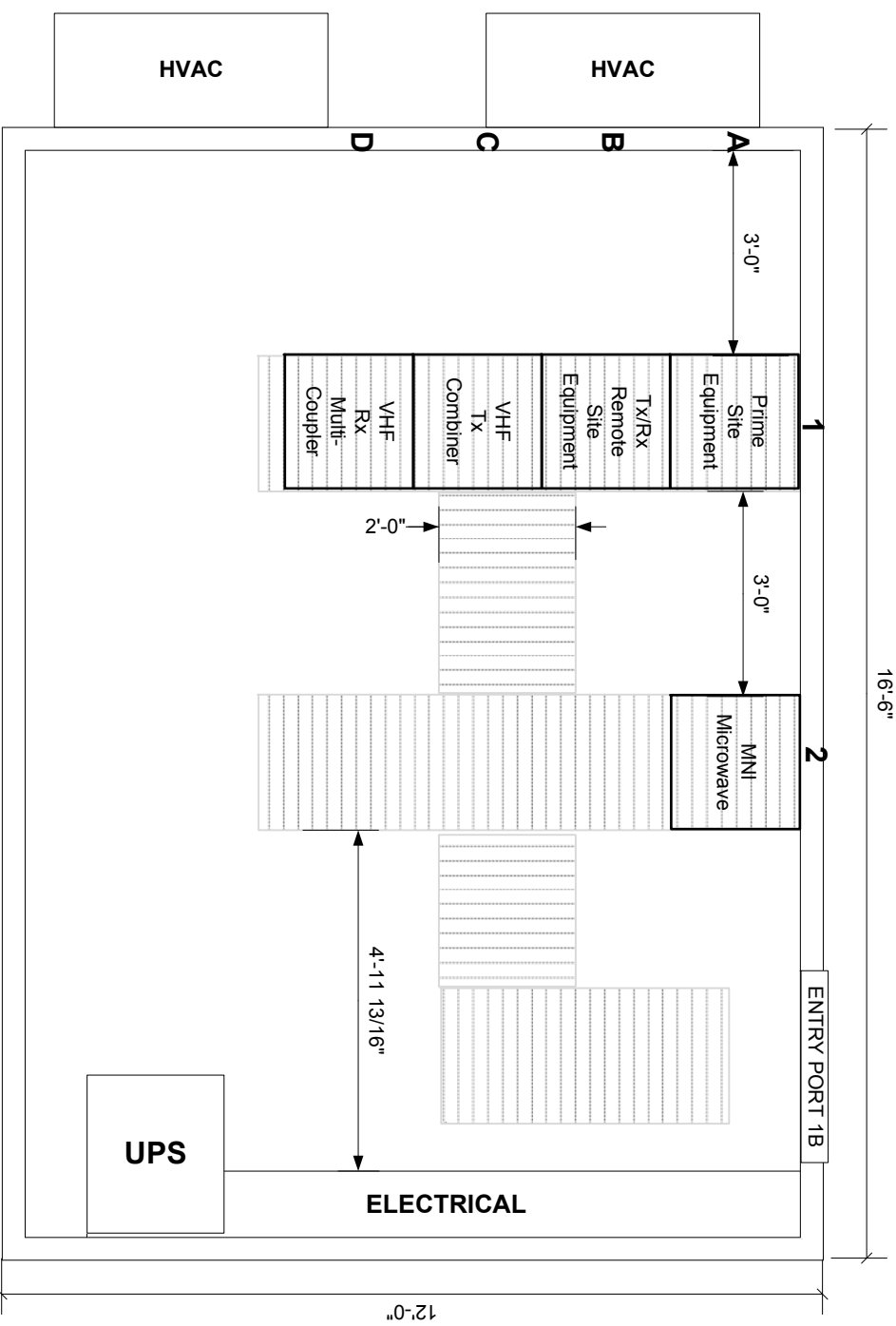

PROJECT: FLUVANNA COUNTY, VA

TITLE: 12' X 16' MSB SHERIFF

DESIGNED BY: MATTHEW TELLEP DATE: 09/12/15

A

B

C

D

E

F

G

8

7

6

5

4

A

B

C

D

E

F

G

H

8

7

6

5

4

3

2

1

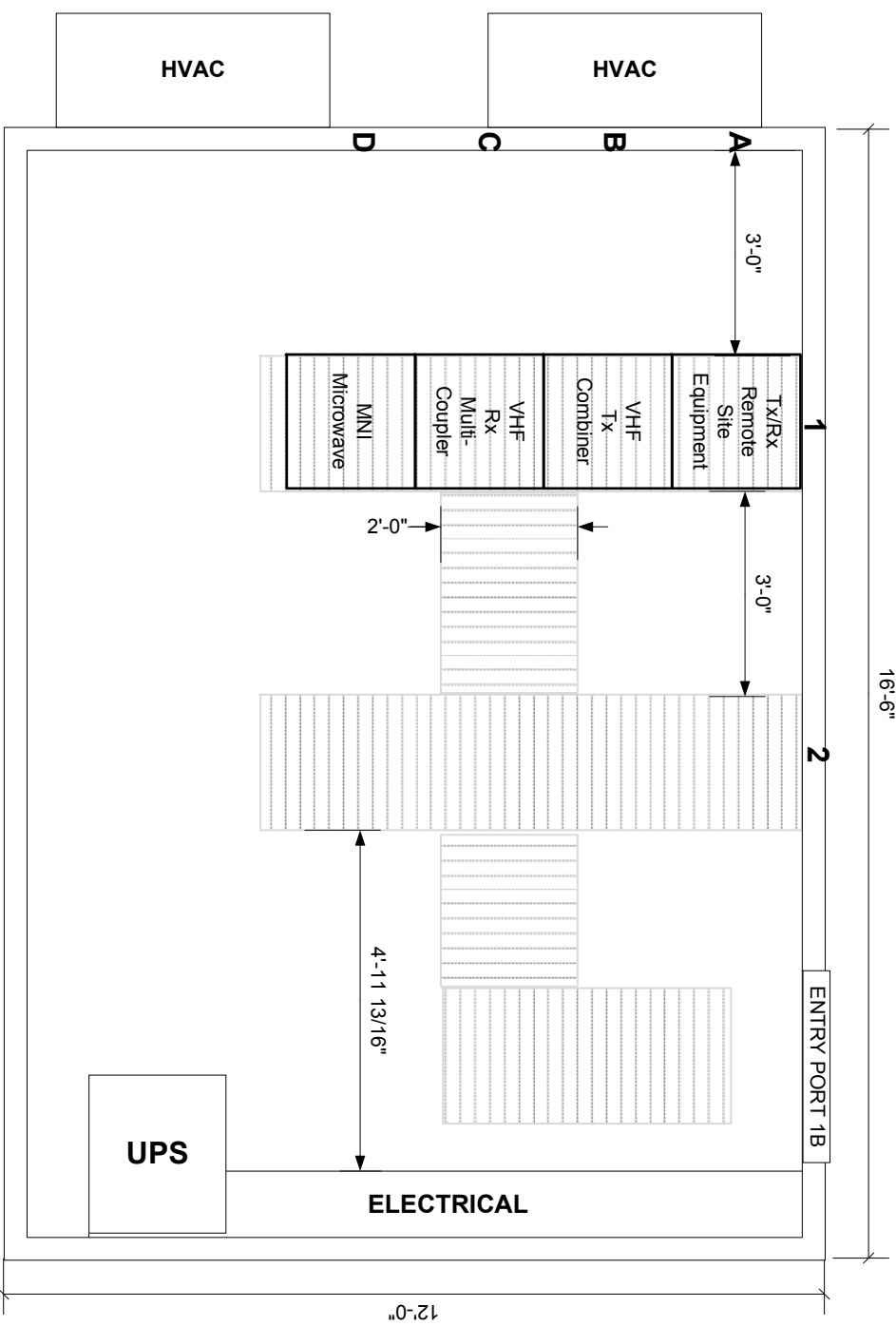

 MOTOROLA	
PROJECT: FLUVANNA COUNTY, VA	
TITLE: 12'X16' MSB TX/RX SITES	
DESIGNED BY: MATTHEW TELLEP	DATE: 09/12/15

8 7 6 5 4 3 2 1

8 7 6 5 4

A

B

C

D

E

F

G

A

B

C

D

E

F

G

H

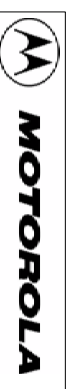
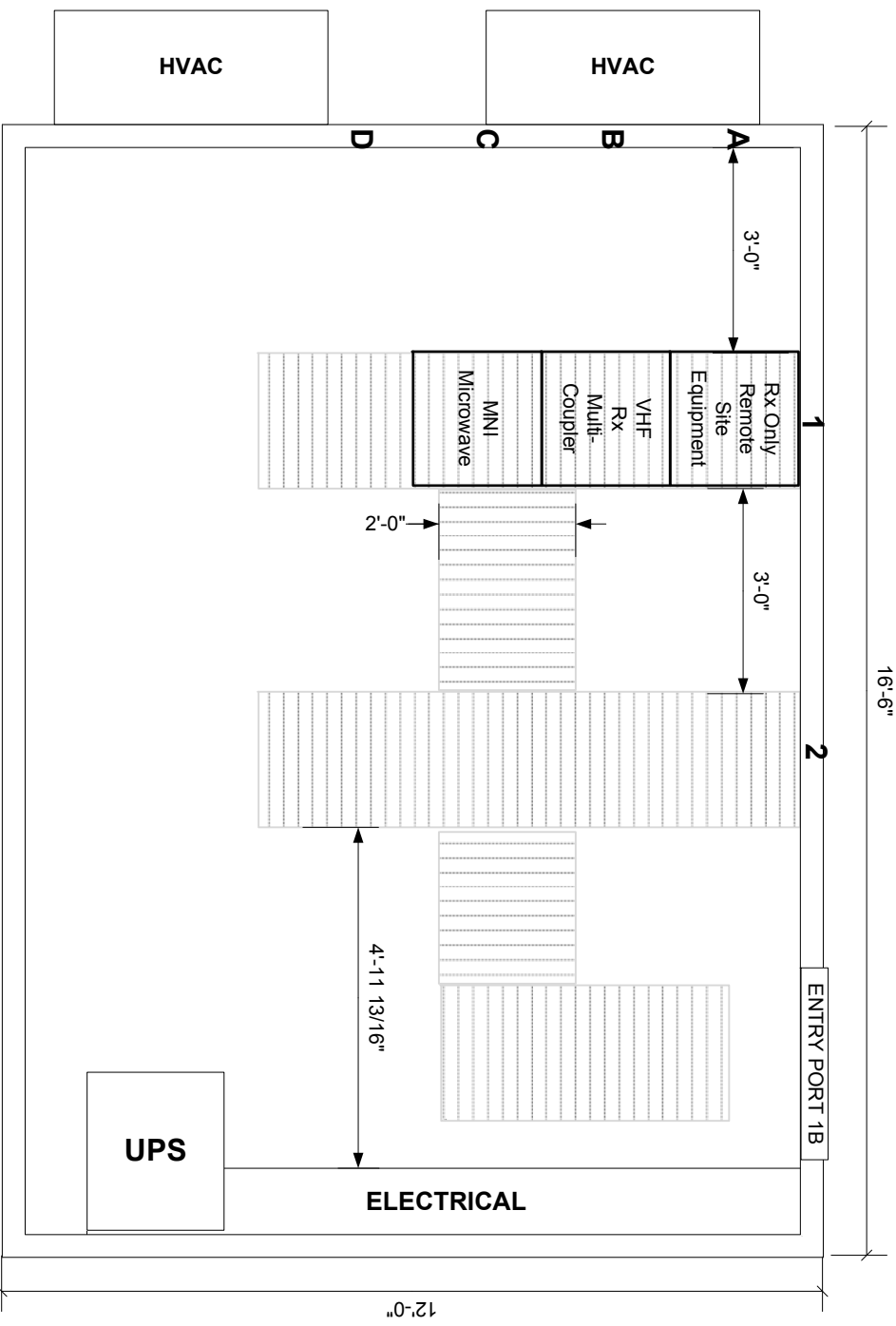

PROJECT: FLUVANNA COUNTY, VA

TITLE: 12' X 16' MSB RX ONLY SITES

DESIGNED BY: MATTHEW TELLEP DATE: 09/12/15

8 7 6 5 4 3 2 1

8 7 6 5 4

A

B

C

D

E

F

G

A

B

C

D

E

F

G

H

Attachment E – L2 Core Master Site System Maintenance Costs

Fluvanna County Post-Warranty Pricing (6/12/2017)

Pricing for: 1 L2 Core P25 Phase 2 TDMA VHF Master Site; 1 Prime Site; 6 RF Remote Sites; 24 Base; 1 Dispatch Ctr; 4 Ops pos; Stations; 1 AIS; 7 MOSCAD RTUs, MNI Microwave, NICE IP Logger and Inform Lite

Based on RF and Prime site Warranty starting 09.01.17, Core and Dispatch Warranty starting 09.05.16, Transition billing period to July-June Fiscal Year Period

ASTRO 25 SERVICES	FY18 Year 2*	FY19 Year 3	FY20 Year 4	FY21 Year 5	FY22 Year 6
Advanced Service includes: 24x7x365 Technical Support Network Hardware Repair Security Patching Onsite Support (Dispatch and Onsite Response) Annual Preventive Maintenance Network Event Monitoring Advanced Plus Service adds Network upgrades in FY19	\$88,106.52	\$287,551.92	\$306,635.04	\$312,073.44	\$319,350.36
Microwave Repair	\$ -	\$14,896.92	\$18,770.40	\$20,086.44	\$34,237.32
NICE Gold Support	\$ -	\$10,875.36	\$11,201.28	\$11,537.28	\$12,239.88
TOTAL MAINTENANCE SERVICES PRICE	\$88,106.52	\$313,324.20	\$336,606.72	\$343,697.16	\$365,827.56
CORE ONLY SERVICES	\$58,503.60	\$156,024.12	\$159,176.88	\$161,637.24	\$164,350.68

* Covers period September 5, 2017 through June 30, 2018

**FLUVANNA COUNTY BOARD OF SUPERVISORS
AGENDA ITEM STAFF REPORT**

MEETING DATE:	November 20, 2018				
AGENDA TITLE:	Approve and Accept Purchases and Deeds (Zion Crossroads Water and Sewer Project)				
MOTION(s):	<p>I move to approve the purchase of the land, permanent easements, and temporary construction easements shown on the plats and plans for the Zion Crossroads Water and Sewer Project where an agreement with the owners as to consideration and terms can be reached; to accept the deeds of conveyance, including any donations, of such property, subject to approval as to form by the County Attorney; to authorize the County Administrator to execute the County's acceptances of the deeds of conveyance and to execute and deliver such other documents as he deems necessary or appropriate to complete the transactions; and to authorize the County Administrator, in consultation with the County Attorney, to approve the final consideration to be paid and to approve the terms of documents in connection with the transactions, including but not limited to any revisions to the deeds of conveyance or any other documents, as he deems necessary or appropriate, consistent with the requirements of the project and within the funds budgeted and appropriated for the project.</p>				
STRATEGIC INITIATIVE?	Yes	No	If yes, list initiative(s):		
AGENDA CATEGORY:	Public Hearing	Action Matter	Presentation	Consent Agenda	Other
		X			
STAFF CONTACT(S):	Frederick W. Payne, County Attorney				
PRESENTER(S):	Frederick W. Payne, County Attorney				
RECOMMENDATION:	Approval				
TIMING:	Immediate				
DISCUSSION:	This action is needed in order to allow the County to proceed with purchases and acceptance of donations of the land and easements needed for the Zion Crossroads Water and Sewer Project, as such purchases and donations are negotiated.				
FISCAL IMPACT:	Included in the project budget.				
POLICY IMPACT:	None				
LEGISLATIVE HISTORY:	N/A				
ENCLOSURES:	Forms of Deed of Easement Form of Deed and Deed of Easement				
REVIEWS COMPLETED:	Legal	Finance	Purchasing	HR	Other
	x				

Prepared by and return to:
Donna R. DeLoria, Esquire (VSB #34133)
Deputy Fluvanna County Attorney
414 East Jefferson Street
Charlottesville, VA 22902

Tax Map: _____

This deed is exempt from recordation tax and Clerk’s fee pursuant to Virginia Code §§ 58.1-811(A)(3) and 17.1-266.

DEED OF EASEMENT

THIS DEED OF EASEMENT, made this _____ day of _____, _____, by and between _____, of the first part (hereinafter, whether one or more, "Grantor"), and the **COUNTY OF FLUVANNA**, a political subdivision of the Commonwealth of Virginia, of the second part (hereinafter "Grantee"), whose address is: P. O. Box 540, Palmyra, Virginia 22963,

WITNESSETH:

WHEREAS Grantor is the owner of certain real property in the County of Fluvanna, Virginia, more particularly described on **Schedule A** attached hereto (the “Property”), and identified as _____, [PIN][PID]: _____ on a plat by Bowman Consulting dated October 1, 2018, entitled “Plat Showing Proposed Utility Easements & Temporary Construction Easements Palmyra Magisterial District Fluvanna County, Virginia and Green Springs Magisterial District Louisa County, Virginia,” recorded in the Clerk’s Office of the Circuit Court of Fluvanna County, Virginia, as Instrument # _____ (the “Plat”);

WHEREAS Grantor is willing to convey to Grantee certain permanent easements and temporary construction easements in the locations shown on the Plat, as more particularly set forth hereinafter;

NOW THEREFORE, for and in consideration of [the premises][\$1.00 and other good and valuable consideration, the receipt and sufficiency of which is hereby acknowledged], Grantor does hereby GRANT and CONVEY with GENERAL WARRANTY and ENGLISH COVENANTS OF TITLE unto Grantee, its successors and assigns, (i) perpetual, non-exclusive easements and rights-of-way over, under, through, upon, and across the Property, for drainage, and to construct, install, maintain, operate, inspect, alter, add to, repair, replace, survey, and extend one or more present and/or future sanitary sewer and/or water lines, together with pipes, pumps, valves, connections, inlet structures, manholes, electric lines and appurtenant facilities, telephone and other communication lines and appurtenant facilities, equipment, facilities, and other appurtenances to a water and/or sewer system, (all of the foregoing, collectively the “Facilities”); and (ii) a temporary construction easement for the construction and installation of the Facilities and the associated water and/or sewer system, including but not limited to staging, storage, and other related activities. The easements granted hereby are shown, respectively, as “Proposed Drainage Easement”, “Proposed Utility Easement”, and “Proposed Temporary Construction Easement” on the Plat. Reference is hereby made to the Plat for a more particular description of the easements and the locations thereof.

Grantor and Grantee agree that:

1. The Facilities shall be and remain the property of Grantee, its successors and assigns.
2. Grantee, its employees, agents, contractors, successors, and/or assigns shall have full and free use of the easements for the purposes stated herein and related activities, and shall have all rights and privileges reasonably necessary to the exercise of the easements, including but not limited to the right of reasonable access to and from the easements over the Property. Without

limitation, Grantor expressly agrees that Grantee shall have the right to assign Grantee's rights hereunder, in whole or in part, to one or more entities authorized to provide public utility service, and as Grantee deems reasonable or necessary to provide for the transmission or distribution of electric power and telephone and other communication service appurtenant to the Facilities.

3. Grantee shall have the right to use any temporary construction easement for the purposes stated herein only during the original construction and installation of the Facilities and the associated water and/or sewer system and for a period of one (1) year thereafter. This right shall not be construed to allow Grantee to erect any building, structure or facility of a permanent nature in the area of any such temporary construction easement and such temporary construction easement shall terminate one (1) year after completion of the original construction and installation of the Facilities and the associated water and/or sewer system.

4. Grantee shall have the right to use land of the Grantor adjoining the easements to the extent necessary to facilitate the uses named; provided, however, that this right to use adjoining land shall be exercised only during periods of actual surveying, installation, construction, reconstruction, replacement, alteration, maintenance, inspection, operation, and/or repair of the Facilities, and then only to the minimum extent necessary for such work; and further, this right to use adjoining land shall not be construed to allow the Grantee to erect any building or structure of a permanent nature on such adjoining land.

5. Grantee shall have the right to trim, cut, and remove trees, shrubbery, fences, structures, or other obstructions or installations in or reasonably near the easements hereby conveyed, deemed by it to interfere with the proper and efficient exercise of the easements; provided however that, except as otherwise provided hereinafter in this deed, Grantee at its own expense shall restore, as nearly as practicable, the surface conditions of the Property to its original

condition, such restoration to include the backfilling of trenches and the reseeding of lawns or pasture areas. Such restoration by Grantee shall not include the ongoing maintenance of any restoration work, the replacement of trees, or the replacement or restoration of structures or other installations deemed by Grantee to interfere with the proper, economical, and efficient exercise of the easements.

6. Grantor reserves the right to construct, maintain, and use roadways, trails, and driveways over the easements (collectively, "Driveways"), and to make other use of the easements; provided that (i) Grantee's standards for the Facilities under or adjacent to any such Driveways, or otherwise applicable to Grantor's intended use, are met; (ii) Grantor's use of the easements may not be inconsistent with the rights herein conveyed; (iii) Grantor's use of the easements may not unreasonably interfere with the use of the easements by Grantee for the purposes stated herein; (iv) Grantor shall not erect any building or structure, including fences (except fences perpendicular to the easements with gates installed over the Facilities), or change the existing ground elevation, or impound any water on the easements, without the prior written approval of Grantee; and (v) Grantor shall not locate new trees within the easements. Any plantings or installations made by Grantor within the easements shall be and remain the property of Grantor. Grantor shall at its sole cost and expense maintain the Property and such plantings or installations made by Grantor. Grantee shall have no responsibility to Grantor to replace or reimburse the cost of any such plantings or installations hereafter made by Grantor, if cut, removed, or otherwise damaged in the exercise of the easements.

7. In the event that hereafter any portion of the land within the easements is accepted by the Commonwealth of Virginia or any appropriate agency thereof for maintenance into the state highway system, all easement rights acquired by Grantee by this instrument in such portion of land

shall cease and terminate, provided that the Commonwealth of Virginia or any appropriate agency thereof concurrently grants to Grantee all necessary permits for the continued operation, maintenance, inspection, alteration, addition to, repair, replacement, and extension of the Facilities in said locations.

8. Grantor, by the execution of this instrument, acknowledges that it has reviewed the Plat, and that the plans for the water and/or sewer systems as they affect the Property have been fully explained to the Grantor or its authorized representative.

9. Grantor covenants and agrees for itself, its heirs, successors, and assigns, that the consideration stated above and paid to it is in lieu of any and all claims to compensation for property, and for damages, if any, to the remaining lands of the Grantor that might result by reason of the use to which the Grantee will put the property to be conveyed.

The signature of Steven M. Nichols, County Administrator, is affixed hereto on behalf of Grantee pursuant to a resolution duly adopted by the Board of Supervisors of the County of Fluvanna, to evidence the acceptance of this deed in accordance with Virginia Code § 15.2-1803, as amended.

[Signature pages follow.]

Witness the following duly authorized signatures and seals.

Name: _____ (SEAL)

STATE OF _____
CITY/COUNTY OF _____, to-wit:

The foregoing instrument was acknowledged before me this _____ day of _____,
_____, by _____.

Notary Public [SEAL]

My commission expires:
Notary registration number:

Name: _____ (SEAL)

STATE OF _____
CITY/COUNTY OF _____, to-wit:

The foregoing instrument was acknowledged before me this _____ day of _____,
_____, by _____.

Notary Public [SEAL]

My commission expires:
Notary registration number:

COUNTY OF FLUVANNA, a political
subdivision of the Commonwealth of Virginia

BY: _____ (SEAL)
STEVEN M. NICHOLS, County Administrator

COMMONWEALTH OF VIRGINIA
COUNTY OF FLUVANNA, to-wit:

The foregoing instrument was acknowledged before me this _____ day of _____,
_____, by Steven M. Nichols, County Administrator, on behalf of the County of Fluvanna,
a political subdivision of the Commonwealth of Virginia.

Notary Public [SEAL]

My commission expires:
Notary registration number:

APPROVED AS TO FORM:

FLUVANNA COUNTY ATTORNEY

SCHEDULE A
(Legal Description)

Prepared by and return to:
Donna R. DeLoria, Esquire (VSB #34133)
Deputy Fluvanna County Attorney
414 East Jefferson Street
Charlottesville, VA 22902

Tax Map: _____
Assessed Value: N/A (not
separately assessed)
Consideration: _____

This deed is exempt from recordation tax and Clerk’s fee pursuant to Virginia Code §§ 58.1-811(A)(3), 58.1-811(C)(5) and 17.1-266.

DEED AND DEED OF EASEMENT

THIS DEED and DEED OF EASEMENT, made this ____ day of _____, _____, by and between _____, of the first part (hereinafter, whether one or more, "Grantor"); the **COUNTY OF FLUVANNA**, a political subdivision of the Commonwealth of Virginia, of the second part (hereinafter "Grantee"), whose address is: P. O. Box 540, Palmyra, Virginia 22963; _____, as **TRUSTEE**, of the third part (hereinafter “Trustee”, to be indexed as a Grantor); and _____, of the fourth part (hereinafter “Lender”, to be indexed as a Grantor);

WITNESSETH:

WHEREAS Grantor is the owner of certain real property in the County of Fluvanna, Virginia, more particularly described on **Schedule A** attached hereto (the “Property”), identified as _____, PIN/PID: _____ on a plat by Bowman Consulting Group, Ltd., dated October 1, 2018, entitled “Plat Showing Proposed Utility Easements & Temporary Construction Easements Palmyra Magisterial District Fluvanna County, Virginia and Green Springs Magisterial District Louisa County, Virginia”, recorded in the Clerk’s Office of the Circuit Court of Fluvanna County, Virginia (the “Clerk’s Office”), as Instrument # _____ (the “Overall Plat”), and identified as PID _____ on a plat by Bowman Consulting Group, Ltd., dated _____, entitled “_____”, recorded in the Clerk’s Office as Instrument # _____ (the “_____ Plat”). Collectively the Overall Plat and the _____ Plat are referred to herein as the “Plats”.

WHEREAS Grantor is willing to convey to Grantee certain land, permanent easements and temporary construction easements as shown on the _____ Plat and the Overall Plat, and as more particularly set forth hereinafter;

WHEREAS Lender is the lender and sole lienholder under (the following collectively, the “Security Documents”) (i) that certain Deed of Trust dated _____, recorded in the Clerk’s Office in Deed Book ____, page ____; and (ii) that certain Assignment of Rents dated _____, recorded in the Clerk’s Office in Deed Book ____, page ____; and Trustee is the Trustee under the foregoing Deed(s) of Trust;

NOW THEREFORE, for and in consideration of [the premises][the sum of \$1.00 and other good and valuable consideration, the receipt and sufficiency of which is hereby acknowledged], Grantor does hereby GRANT and CONVEY with GENERAL WARRANTY and ENGLISH COVENANTS OF TITLE unto Grantee, its successors and assigns, in fee simple, the following described property, to wit (the “Land”):

[Describe the land to be acquired in fee simple];

TOGETHER WITH (i) perpetual, non-exclusive easements and rights-of-way over, under, through, upon, and across the Property, [for ingress and egress,][for drainage, and] to construct, install, maintain, operate, inspect, alter, add to, repair, replace, survey, and extend one or more present and/or future sanitary sewer and/or water lines, together with pipes, pumps, valves, connections, inlet structures, manholes, electric lines and appurtenant facilities, telephone and other communication lines and appurtenant facilities, equipment, facilities, and other appurtenances to a water and/or sewer system, (all of the foregoing, collectively the “Facilities”); and (ii) a temporary construction easement for the construction and installation of the Facilities and the associated water and/or sewer system, including but not limited to staging, storage, and other related activities. The easements granted hereby are shown, respectively, as “Proposed _____” [and “Proposed _____”] on the _____ Plat, and as “Proposed _____” [and “Proposed _____”] on the Overall

Plat. Reference is hereby made to the Plats for a more particular description of the Land, the easements, and the locations thereof.

Grantor and Grantee agree that:

1. The Facilities shall be and remain the property of Grantee, its successors and assigns.
2. Grantee, its employees, agents, contractors, successors, and/or assigns shall have full and free use of the easements for the purposes stated herein and related activities, and shall have all rights and privileges reasonably necessary to the exercise of the easements, including but not limited to the right of reasonable access to and from the easements over the Property. Without limitation, Grantor expressly agrees that Grantee shall have the right to assign Grantee's rights hereunder, in whole or in part, to one or more entities authorized to provide public utility service, and as Grantee deems reasonable or necessary to provide for the transmission or distribution of electric power and telephone and other communication service appurtenant to the Facilities.
3. Grantee shall have the right to use any temporary construction easement for the purposes stated herein only during the original construction and installation of the Facilities and the associated water and/or sewer system and for a period of one (1) year thereafter. This right shall not be construed to allow Grantee to erect any building, structure or facility of a permanent nature in the area of any such temporary construction easement and such temporary construction easement shall terminate one (1) year after completion of the original construction and installation of the Facilities and the associated water and/or sewer system.
4. Grantee shall have the right to use land of the Grantor adjoining the easements to the extent necessary to facilitate the uses named; provided, however, that this right to use adjoining land shall be exercised only during periods of actual surveying, installation, construction, reconstruction, replacement, alteration, maintenance, inspection, operation, and/or repair of the Facilities, and then only to the minimum extent necessary for such work; and further, this right to

use adjoining land shall not be construed to allow the Grantee to erect any building or structure of a permanent nature on such adjoining land.

5. Grantee shall have the right to trim, cut, and remove trees, shrubbery, fences, structures, or other obstructions or installations in or reasonably near the easements hereby conveyed, deemed by it to interfere with the proper and efficient exercise of the easements; provided however that, except as otherwise provided hereinafter in this deed, Grantee at its own expense shall restore, as nearly as practicable, the surface conditions of the Property to its original condition, such restoration to include the backfilling of trenches and the reseeded of lawns or pasture areas. Such restoration by Grantee shall not include the ongoing maintenance of any restoration work, the replacement of trees, or the replacement or restoration of structures or other installations deemed by Grantee to interfere with the proper, economical, and efficient exercise of the easements.

6. Grantor reserves the right to construct, maintain, and use roadways, trails, and driveways over the easements (collectively, "Driveways"), and to make other use of the easements; provided that (i) Grantee's standards for the Facilities under or adjacent to any such Driveways, or otherwise applicable to Grantor's intended use, are met; (ii) Grantor's use of the easements may not be inconsistent with the rights herein conveyed; (iii) Grantor's use of the easements may not unreasonably interfere with the use of the easements by Grantee for the purposes stated herein; (iv) Grantor shall not erect any building or structure, including fences (except fences perpendicular to the easements with gates installed over the Facilities), or change the existing ground elevation, or impound any water on the easements, without the prior written approval of Grantee; and (v) Grantor shall not locate new trees within the easements. Any plantings or installations made by Grantor within the easements shall be and remain the property of Grantor. Grantor shall at its sole cost and expense maintain the Property and such plantings or installations made by Grantor. Grantee shall have no responsibility to Grantor to replace or reimburse the cost of any such plantings or installations hereafter made by Grantor, if cut, removed, or otherwise damaged in the

exercise of the easements.

7. In the event that hereafter any portion of the land within the easements is accepted by the Commonwealth of Virginia or any appropriate agency thereof for maintenance into the state highway system, all easement rights acquired by Grantee by this instrument in such portion of land shall cease and terminate, provided that the Commonwealth of Virginia or any appropriate agency thereof concurrently grants to Grantee all necessary permits for the continued operation, maintenance, inspection, alteration, addition to, repair, replacement, and extension of the Facilities in said locations.

8. Grantor, by the execution of this instrument, acknowledges that it has reviewed the Plats, and that the plans for the water and/or sewer systems as they affect the Property have been fully explained to the Grantor or its authorized representative.

9. Grantor covenants and agrees for itself, its heirs, successors, and assigns, that the consideration stated above and paid to it is in lieu of any and all claims to compensation for property, and for damages, if any, to the remaining lands of the Grantor that might result by reason of the use to which the Grantee will put the property to be conveyed.

The property hereby conveyed is subject to any and all easements, restrictions, reservations, and conditions contained in duly recorded deeds, plats and other instruments constituting constructive notice in the chain of title to the above described property which have not expired by a time limitation contained therein or have not otherwise become ineffective.

Lender and Trustee, at Lender's direction, join in this deed to evidence their consent hereto, and do hereby:

- (i) RELEASE the Land from the lien and obligations of the Security Documents; and
- (ii) agree that the lien and obligations of the Security Documents shall hereafter be
SUBJECT AND SUBORDINATE to the easements and agreements set forth herein.

The signature of Steven M. Nichols, County Administrator, is affixed hereto on behalf of Grantee pursuant to a resolution duly adopted by the Board of Supervisors of the County of

Fluvanna, to evidence the acceptance of this deed in accordance with Virginia Code § 15.2-1803, as amended.

[Signature pages follow.]

Witness the following duly authorized signatures and seals made after proper approval by the company.

By: _____ (SEAL)
Name and title: _____

By: _____ (SEAL)
Name and title: _____

STATE OF _____
CITY/COUNTY OF _____, to-wit:

The foregoing instrument was acknowledged before me this _ day of _____,
_____, by _____, _____ (title) of _____
on behalf of the _____.

Notary Public [SEAL]

My commission expires:
Notary registration number:

STATE OF _____
CITY/COUNTY OF _____, to-wit:

The foregoing instrument was acknowledged before me this _ day of _____,
_____, by _____, _____ (title) of _____
on behalf of the _____.

Notary Public [SEAL]

My commission expires:
Notary registration number:

COUNTY OF FLUVANNA, a political
subdivision of the Commonwealth of Virginia

BY: _____ (SEAL)
STEVEN M. NICHOLS, County Administrator

COMMONWEALTH OF VIRGINIA
COUNTY OF FLUVANNA, to-wit:

The foregoing instrument was acknowledged before me this _____ day of _____,
_____, by Steven M. Nichols, County Administrator, on behalf of the County of Fluvanna,
a political subdivision of the Commonwealth of Virginia.

Notary Public [SEAL]

My commission expires:
Notary registration number:

APPROVED AS TO FORM:

FLUVANNA COUNTY ATTORNEY

By: _____ (SEAL)

Printed Name: _____

Title: _____

STATE OF _____
CITY/COUNTY OF _____, to-wit:

The foregoing instrument was acknowledged before me this _____ day of _____,
_____, by _____, _____ of
_____.

Notary Public

[SEAL]

My commission expires:
Notary registration number:

_____, TRUSTEE

By: _____ (SEAL)

Printed Name: _____

Title: _____

STATE OF _____
CITY/COUNTY OF _____, to-wit:

The foregoing instrument was acknowledged before me this _____ day of _____,
_____, by _____, _____ of
_____, Trustee.

Notary Public

[SEAL]

My commission expires:
Notary registration number:

SCHEDULE A
(Legal Description)

**FLUVANNA COUNTY BOARD OF SUPERVISORS
AGENDA ITEM STAFF REPORT**

TAB S

MEETING DATE:	November 20, 2018																																																																										
AGENDA TITLE:	FY18 4 th Quarter Budget Report and FY18 to FY19 Carryover Requests																																																																										
MOTION(s):	<p>I move the Board of Supervisors [approve/deny/defer] the following carryover requests of FY18 unexpended budget lines from the listed departments to the FY19 Department Budget lines as specified and in the amounts listed:</p>																																																																										
	<table border="1"> <thead> <tr> <th>Item</th> <th>Department</th> <th>Budget Line</th> <th>Amount</th> <th>Meets Policy</th> </tr> </thead> <tbody> <tr> <td>A</td> <td>Cooperative Extension</td> <td>Contract Services</td> <td>\$14,600</td> <td>No</td> </tr> <tr> <td>B</td> <td>Cooperative Extension</td> <td>Contract Services</td> <td>\$4,300</td> <td>No</td> </tr> <tr> <td>C</td> <td>E911</td> <td>Overtime Pay</td> <td>\$6,000</td> <td>Yes</td> </tr> <tr> <td>D</td> <td>E911</td> <td>Maintenance Contracts</td> <td>\$8,000</td> <td>No</td> </tr> <tr> <td>E</td> <td>E911</td> <td>Telecomm.</td> <td>\$5,000</td> <td>No</td> </tr> <tr> <td>F</td> <td>E911</td> <td>IT Services</td> <td>\$7,000</td> <td>Yes</td> </tr> <tr> <td>G</td> <td>Fire & Rescue</td> <td>F&R Capital</td> <td>\$175,000</td> <td>Yes</td> </tr> <tr> <td>H</td> <td>Parks & Rec.</td> <td>Site Improvement</td> <td>\$4,000</td> <td>Yes</td> </tr> <tr> <td>I</td> <td>Registrar's Office</td> <td>*Ballots</td> <td>\$5,000</td> <td>No</td> </tr> <tr> <td>J</td> <td>Sheriff's Office</td> <td>Bldgs Equip Rep & Maint</td> <td>\$30,076.71</td> <td>No</td> </tr> <tr> <td>K</td> <td>Sheriff's Office</td> <td>Convention and Education</td> <td>\$8,000</td> <td>No</td> </tr> <tr> <td>L</td> <td>Sheriff's Office</td> <td>Police Supplies</td> <td>\$3,800</td> <td>No</td> </tr> <tr> <td>M</td> <td>Sheriff's Office (ACO)</td> <td>Contract Services</td> <td>\$2,904.15</td> <td>No</td> </tr> </tbody> </table>	Item	Department	Budget Line	Amount	Meets Policy	A	Cooperative Extension	Contract Services	\$14,600	No	B	Cooperative Extension	Contract Services	\$4,300	No	C	E911	Overtime Pay	\$6,000	Yes	D	E911	Maintenance Contracts	\$8,000	No	E	E911	Telecomm.	\$5,000	No	F	E911	IT Services	\$7,000	Yes	G	Fire & Rescue	F&R Capital	\$175,000	Yes	H	Parks & Rec.	Site Improvement	\$4,000	Yes	I	Registrar's Office	*Ballots	\$5,000	No	J	Sheriff's Office	Bldgs Equip Rep & Maint	\$30,076.71	No	K	Sheriff's Office	Convention and Education	\$8,000	No	L	Sheriff's Office	Police Supplies	\$3,800	No	M	Sheriff's Office (ACO)	Contract Services	\$2,904.15	No	<p>with a total amount of \$ _____ to be re-appropriated to FY19.</p>			
Item	Department	Budget Line	Amount	Meets Policy																																																																							
A	Cooperative Extension	Contract Services	\$14,600	No																																																																							
B	Cooperative Extension	Contract Services	\$4,300	No																																																																							
C	E911	Overtime Pay	\$6,000	Yes																																																																							
D	E911	Maintenance Contracts	\$8,000	No																																																																							
E	E911	Telecomm.	\$5,000	No																																																																							
F	E911	IT Services	\$7,000	Yes																																																																							
G	Fire & Rescue	F&R Capital	\$175,000	Yes																																																																							
H	Parks & Rec.	Site Improvement	\$4,000	Yes																																																																							
I	Registrar's Office	*Ballots	\$5,000	No																																																																							
J	Sheriff's Office	Bldgs Equip Rep & Maint	\$30,076.71	No																																																																							
K	Sheriff's Office	Convention and Education	\$8,000	No																																																																							
L	Sheriff's Office	Police Supplies	\$3,800	No																																																																							
M	Sheriff's Office (ACO)	Contract Services	\$2,904.15	No																																																																							
STRATEGIC INITIATIVE?	Yes	No	If yes, list initiative(s):																																																																								
		X																																																																									
AGENDA CATEGORY:	Public Hearing	Action Matter	Presentation	Consent Agenda	Other																																																																						
		XX																																																																									
STAFF CONTACT(S):	Eric Pollitt, Management Analyst Eric Dahl, Finance Director Steve Nichols, County Administrator Aaron Spitzer, Parks & Rec. Director Captain Von Hill, Sheriff's Office Michael Grandstaff, e911 Dispatch Communications Joyce Pace, Registrar's Office Kim Mayo, Cooperative Extension Richie Constantino, LMFR																																																																										
PRESENTER(S):	Eric Pollitt, Management Analyst																																																																										

RECOMMENDATION:	Approve carryovers within policy				
TIMING:	Effective July 1, 2018				
DISCUSSION:	<p>Presenting the FY18 4th Quarter Budget Report for BOS information and the FY18 to FY19 Carryover Requests for BOS consideration and action.</p> <p>Fluvanna County Finance Policy Section 3.1.10, Reappropriation of Balances (Carryovers):</p> <p><u>Meets existing policy</u></p> <ol style="list-style-type: none"> 1. Had budget authority in FY18, and 2. Initiative/project was started in FY18, but was not able to be completed, or 3. Initiative/project not started in FY18 due to circumstances. <p><u>Does not meet existing policy</u></p> <ol style="list-style-type: none"> 1. No budget authority in FY18, and requesting FY18 carryover of remaining funds to 2. Cover certain one-time special or capital projects not already approved/funded, or to cover unanticipated operating expenses not included in the FY19 budget 				
FISCAL IMPACT:	Approval of the motion as stated above will allow the Finance Department to increase FY19 revenue and expenditure budgets equally within the assigned funds.				
POLICY IMPACT:	N/A				
LEGISLATIVE HISTORY:	Financial Policies 3.1.10 Reappropriation of Balances (Carryovers)				
ENCLOSURES:	<ul style="list-style-type: none"> • FY18 4th Quarter Budget Report • Policy Section 3.1.10, Reappropriation of Balances (Carryovers) • Office/Departmental Carryover Requests Forms 				
REVIEWS COMPLETED:	Legal	Finance	Purchasing	HR	Other
		X			



FY18 4th Quarter Budget Report

November 20th, 2018

Eric Dahl, Deputy County Admin./Finance Director

Eric Pollitt, Management Analyst



FY18 4th Quarter Budget Report

BOS 2018-11-20 p.154/421

- **The majority of Offices & Departments ended FY18 within 90%-100% of their budgets**
- **County and School Operational Budgets show over \$2.6 Million in available funds**
- **Over \$9.2 Million was spent on capital projects with over \$3.6 Million available**



FY18 4th Quarter Budget Report

FY18 OPERATIONAL EXPENSES

- **TOTAL OPERATIONAL EXPENSES**
- \$21,570,601.94
- **TOTAL SCHOOL EXPENSES**
- \$38,818,258.70
- **TOTAL CAFETERIA EXPENSES**
- \$1,359,728.04
- **TOTAL DEBT SERVICE EXPENSES**
- \$8,861,882.61
- **TOTAL UTILITY FUNDS EXPENSES**
- \$715,977.41

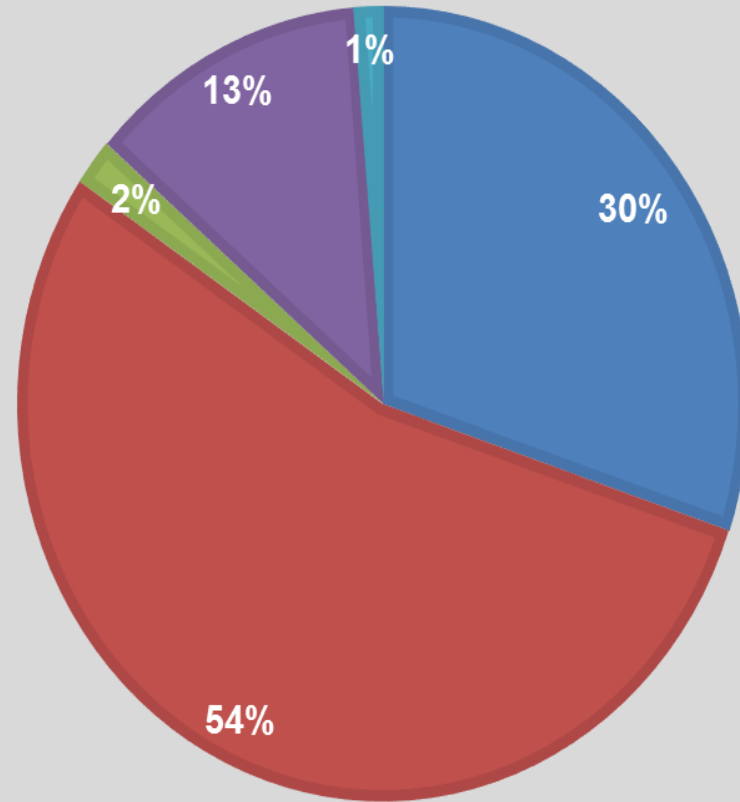



FY18 4th Quarter Budget Report

- **Of the \$1.08 million remaining, the County ended FY18 significantly under budget in the following areas:**
 - Clerk of Circuit Court: \$39,546
 - Registrar/ Electoral Board: \$30,798
 - Emergency Management: \$70,602
 - Sheriff & e911: \$129,269
 - Parks & Recreation: \$62,271
 - CSA Purchase of Services: \$185,432
 - Misc. Non-Departmental: \$86,138



FY18 4th Quarter Budget Report - ZXR

- Redemption of Interest: \$249,218

- Professional Services: \$155,392
- County Attorney: \$34,897
- Bond Issuance: \$140,760
- Advertising: \$217
- **TOTAL: \$331,267**

- **\$580,485**



FY18 4th Quarter Budget Report - Capital

FY18 CAPITAL EXPENSES BY FUNCTION

- **TOTAL PUBLIC SAFETY**
- \$982,850
- **TOTAL PUBLIC WORKS**
- \$4,802,711
- **TOTAL EDUCATION**
- \$1,525,561
- **TOTAL PARKS, REC. & CULTURAL**
- \$332,592
- **TOTAL GENERAL GOVERNMENT & NONDEPARTMENTAL**
- \$1,600,238

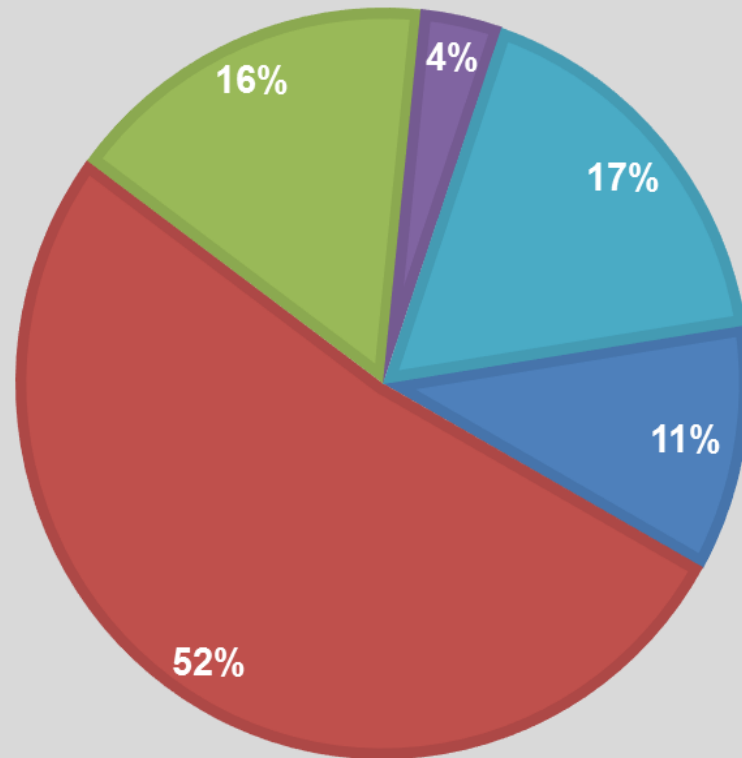



FY18 4th Quarter Budget Report

Questions?

	ORIGINAL APPROP	TRANFRS/ ADJSTMTS	REVISED BUDGET	YTD EXPENDED	ENQ / REQ	AVAILABLE BUDGET	PCT USED
OPERATIONAL							
TOTAL OPERATIONAL EXPENSES	21,768,073	892,527	22,660,600	21,570,602	-	1,089,998	95.2%
TOTAL SCHOOL EXPENSES	39,634,787	715,000	40,349,787	38,823,900	-	1,525,887	96.2%
TOTAL CAFETERIA EXPENSES	1,597,046	-	1,597,046	1,359,728	-	237,318	85.1%
TOTAL DEBT SERVICE EXPENSES	10,468,627	(1,599,618)	8,869,009	8,861,883	-	7,126	99.9%
TOTAL PALMYRA SEWER EXPENSES	354,563	(65)	354,498	305,394	-	49,104	86.1%
TOTAL FUSD EXPENSES	354,719	3,792	358,511	345,770	-	12,741	96.4%
TOTAL ZION X ROADS EXPENSES	-	224,852	224,852	249,219	-	(24,367)	110.8%
TOTAL	74,177,815	236,488	74,414,303	71,516,495	-	2,897,808	96.1%
FY18 CIP	1,447,100						
GRAND TOTAL	75,624,915						

CAPITAL

TOTAL ZION X ROADS EXPENSES	-	8,791,312	8,791,312	331,267	-	8,460,045	3.8%
TOTAL CAPITAL IMPROVEMENT FUND	10,964,523	1,956,509	12,921,032	9,244,000	-	3,677,032	71.5%

** Report Generated by Eric S. Pollitt**

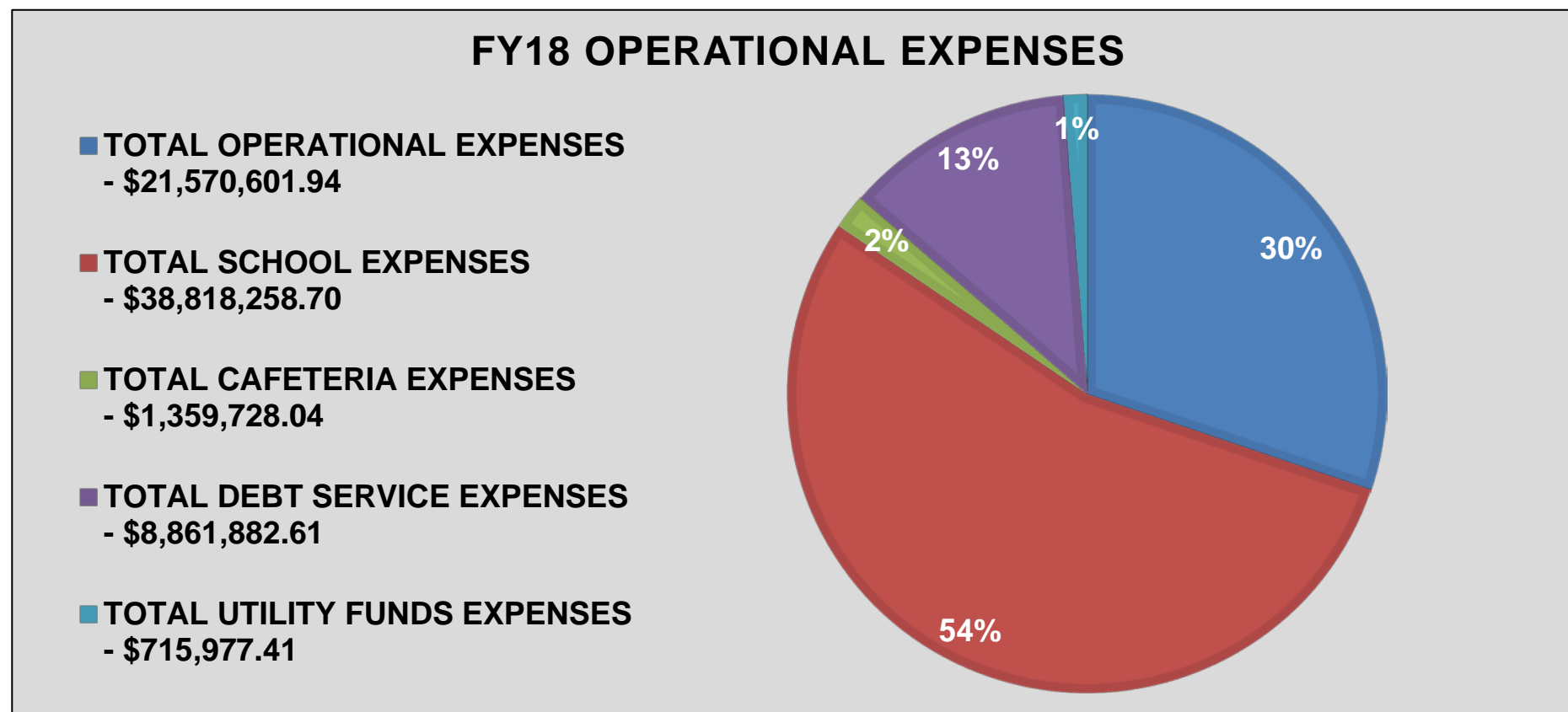



10/30/2018 14:34
5311epol

COUNTY OF FLUVANNA
FY18 Q4 YEAR-TO-DATE BUDGET REPORT

P 1
glytdbud

FOR 2018 12

ACCOUNTS FOR: 100 GENERAL FUND	ORIGINAL APPROP	TRANFRS/ ADJSTMTS	REVISED BUDGET	YTD EXPENDED	ENCUMBRANCES	AVAILABLE BUDGET	PCT USED
110 BOARD OF SUPERVISORS							
10011000 401114 BOARD COMPENSATION	43,800	-3,000	40,800	40,799.98	.00	.02	100.0%
10011000 401335 TECHNOLOGY STIPEND	0	689	689	688.20	.00	.80	99.9%
10011000 402100 FICA	3,351	0	3,351	2,330.57	.00	1,020.43	69.5%
10011000 402300 MEDICAL INSURANCE	26,760	2,737	29,497	29,496.72	.00	.28	100.0%
10011000 402700 WORKER'S COMPENSAT	39	0	39	19.32	.00	19.68	49.5%
10011000 403100 PROFESSIONAL SERVI	53,000	18,132	71,132	72,282.00	.00	-1,150.00	101.6%*
10011000 403300 CONTRACT SERVICES	5,000	0	5,000	5,238.72	.00	-238.72	104.8%*
10011000 403500 PRINTING AND BINDI	200	3,000	3,200	3,330.12	.00	-130.12	104.1%*
10011000 403600 ADVERTISING	2,500	0	2,500	5,884.03	.00	-3,384.03	235.4%*
10011000 405210 POSTAL SERVICES	400	0	400	504.93	.00	-104.93	126.2%*
10011000 405230 TELECOMMUNICATIONS	3,620	0	3,620	2,035.54	.00	1,584.46	56.2%
10011000 405307 PUBLIC OFFICIALS L	9,800	0	9,800	9,431.00	.00	369.00	96.2%
10011000 405510 MILEAGE ALLOWANCES	1,750	0	1,750	1,511.90	.00	238.10	86.4%
10011000 405530 SUBSISTENCE & LODG	4,500	0	4,500	2,666.50	.00	1,833.50	59.3%
10011000 405540 CONVENTION AND EDU	1,800	0	1,800	1,010.00	.00	790.00	56.1%
10011000 405810 DUES OR ASSOCIATIO	7,200	0	7,200	7,973.00	.00	-773.00	110.7%*
10011000 406001 OFFICE SUPPLIES	750	0	750	74.50	.00	675.50	9.9%
10011000 406012 BOOKS/PUBLICATIONS	1,250	0	1,250	1,203.44	.00	46.56	96.3%
10011000 406014 OTHER OPERATING SU	2,450	0	2,450	2,607.19	.00	-157.19	106.4%*
TOTAL BOARD OF SUPERVISORS	168,170	21,558	189,728	189,087.66	.00	640.34	99.7%



10/30/2018 14:34
5311epol

COUNTY OF FLUVANNA
FY18 Q4 YEAR-TO-DATE BUDGET REPORT

P 2
glytdbud

FOR 2018 12

ACCOUNTS FOR: 100 GENERAL FUND	ORIGINAL APPROP	TRANFRS/ ADJSTMTS	REVISED BUDGET	YTD EXPENDED	ENCUMBRANCES	AVAILABLE BUDGET	PCT USED
120 COUNTY ADMINISTRATOR							
10012000 401100 FULL-TIME SALARIES	169,179	1,860	171,039	171,688.77	.00	-649.77	100.4%*
10012000 401300 PART-TIME SALARIES	1,440	3,958	5,398	3,358.00	.00	2,040.00	62.2%
10012000 401335 TECHNOLOGY STIPEND	1,200	0	1,200	1,199.90	.00	.10	100.0%
10012000 401336 VEHICLE STIPEND	4,800	0	4,800	4,800.12	.00	-.12	100.0%*
10012000 402100 FICA	13,511	445	13,956	13,302.43	.00	653.57	95.3%
10012000 402210 VRS	14,499	159	14,658	14,643.60	.00	14.40	99.9%
10012000 402250 DISABILITY	280	0	280	282.84	.00	-2.84	101.0%*
10012000 402300 MEDICAL INSURANCE	11,700	-1,226	10,474	10,474.42	.00	-.42	100.0%*
10012000 402400 GROUP LIFE	2,216	24	2,240	2,238.36	.00	1.64	99.9%
10012000 402700 WORKER'S COMPENSAT	154	0	154	161.38	.00	-7.38	104.8%*
10012000 403600 ADVERTISING	0	0	0	236.25	.00	-236.25	100.0%*
10012000 405210 POSTAL SERVICES	410	0	410	606.66	.00	-196.66	148.0%*
10012000 405230 TELECOMMUNICATIONS	750	0	750	462.98	.00	287.02	61.7%
10012000 405410 LEASE/RENT	6,600	0	6,600	7,117.60	.00	-517.60	107.8%*
10012000 405510 MILEAGE ALLOWANCES	550	0	550	690.99	.00	-140.99	125.6%*
10012000 405530 SUBSISTENCE & LODG	1,100	0	1,100	1,317.39	.00	-217.39	119.8%*
10012000 405540 CONVENTION AND EDU	1,200	0	1,200	595.00	.00	605.00	49.6%
10012000 405810 DUES OR ASSOCIATIO	1,610	0	1,610	1,877.26	.00	-267.26	116.6%*
10012000 406001 OFFICE SUPPLIES	2,500	0	2,500	3,106.24	.00	-606.24	124.2%*
10012000 406012 BOOKS/PUBLICATIONS	200	0	200	22.80	.00	177.20	11.4%
10012000 406014 OTHER OPERATING SU	0	0	0	19.45	.00	-19.45	100.0%*
10012000 408102 FURNITURE & FIXTUR	500	0	500	152.62	.00	347.38	30.5%
TOTAL COUNTY ADMINISTRATOR	234,399	5,220	239,619	238,355.06	.00	1,263.94	99.5%



10/30/2018 14:34
5311epol

COUNTY OF FLUVANNA
FY18 Q4 YEAR-TO-DATE BUDGET REPORT

P 3
glytdbud

FOR 2018 12

ACCOUNTS FOR: 100 GENERAL FUND	ORIGINAL APPROP	TRANFRS/ ADJSTMTS	REVISED BUDGET	YTD EXPENDED	ENCUMBRANCES	AVAILABLE BUDGET	PCT USED
125 COUNTY ATTORNEY							
<u>10012500 403100 PROFESSIONAL SERVI</u>	275,000	16,492	291,492	.00	.00	291,492.00	.0%
<u>10012500 403101 COUNTY ATTY LEGAL-</u>	0	0	0	120,000.00	.00	-120,000.00	100.0%*
<u>10012500 403102 COUNTY ATTY LEGAL-</u>	0	0	0	28,453.96	.00	-28,453.96	100.0%*
<u>10012500 403103 COUNTY ATTY LEGAL-</u>	0	0	0	56,082.60	.00	-56,082.60	100.0%*
<u>10012500 403104 COUNTY ATTY LEGAL-</u>	0	0	0	39,642.39	.00	-39,642.39	100.0%*
<u>10012500 403105 COUNTY ATTY LEGAL-</u>	0	0	0	779.94	.00	-779.94	100.0%*
TOTAL COUNTY ATTORNEY	275,000	16,492	291,492	244,958.89	.00	46,533.11	84.0%



10/30/2018 14:34
5311epol

COUNTY OF FLUVANNA
FY18 Q4 YEAR-TO-DATE BUDGET REPORT

P 4
glytddb

FOR 2018 12

ACCOUNTS FOR: 100 GENERAL FUND	ORIGINAL APPROP	TRANFRS/ ADJSTMTS	REVISED BUDGET	YTD EXPENDED	ENCUMBRANCES	AVAILABLE BUDGET	PCT USED
130 COMMISSIONER OF THE REVENUE							
10013000 401100 FULL-TIME SALARIES	255,068	3,003	258,071	258,071.31	.00	-.31	100.0%*
10013000 402100 FICA	19,513	230	19,743	19,327.49	.00	415.51	97.9%
10013000 402210 VRS	21,859	258	22,117	21,549.24	.00	567.76	97.4%
10013000 402250 DISABILITY	401	0	401	403.95	.00	-2.95	100.7%*
10013000 402300 MEDICAL INSURANCE	24,360	-7,011	17,349	17,348.88	.00	.12	100.0%
10013000 402400 GROUP LIFE	3,341	39	3,380	3,380.76	.00	-.76	100.0%*
10013000 402700 WORKER'S COMPENSAT	230	0	230	195.89	.00	34.11	85.2%
10013000 403100 PROFESSIONAL SERVI	18,770	-3,164	15,606	15,527.49	.00	78.26	99.5%
10013000 403310 BLDGS EQUIP REP &	600	-236	364	306.58	.00	57.71	84.2%
10013000 403500 PRINTING AND BINDI	2,000	-1,077	923	922.95	.00	.00	100.0%
10013000 403600 ADVERTISING	200	1,512	1,712	1,712.22	.00	.00	100.0%
10013000 405210 POSTAL SERVICES	1,540	0	1,540	1,522.99	.00	17.01	98.9%
10013000 405230 TELECOMMUNICATIONS	1,100	128	1,228	1,228.06	.00	.00	100.0%
10013000 405410 LEASE/RENT	5,530	178	5,708	5,708.04	.00	.00	100.0%
10013000 405510 MILEAGE ALLOWANCES	300	-300	0	.00	.00	.00	.0%
10013000 405530 SUBSISTENCE & LODG	1,500	12	1,512	1,511.50	.00	.00	100.0%
10013000 405540 CONVENTION AND EDU	1,800	0	1,800	1,796.00	.00	4.00	99.8%
10013000 405810 DUES OR ASSOCIATIO	515	115	630	630.00	.00	.00	100.0%
10013000 406001 OFFICE SUPPLIES	2,000	1,377	3,377	3,306.97	.00	70.08	97.9%
10013000 406008 VEHICLE FUEL	600	0	600	224.27	.00	375.73	37.4%
10013000 406021 ADP SUPPLIES	400	-397	3	.00	.00	2.58	.0%
10013000 408102 FURNITURE & FIXTUR	1,500	-64	1,436	1,435.71	.00	.00	100.0%
10013000 408107 EDP EQUIPMENT	500	1,917	2,417	2,416.85	.00	.00	100.0%
TOTAL COMMISSIONER OF THE REVENUE	363,627	-3,481	360,146	358,527.15	.00	1,618.85	99.6%



10/30/2018 14:34
5311epol

COUNTY OF FLUVANNA
FY18 Q4 YEAR-TO-DATE BUDGET REPORT

P 5
glytdbud

FOR 2018 12

ACCOUNTS FOR: 100 GENERAL FUND	ORIGINAL APPROP	TRANFRS/ ADJSTMTS	REVISED BUDGET	YTD EXPENDED	ENCUMBRANCES	AVAILABLE BUDGET	PCT USED
135 REASSESSMENT							
<u>10013500 401114 BOARD COMPENSATION</u>	4,500	-1,800	2,700	2,183.00	.00	517.00	80.9%
<u>10013500 401300 PART-TIME SALARIES</u>	2,000	1,800	3,800	2,697.00	.00	1,103.00	71.0%
<u>10013500 402100 FICA</u>	497	0	497	373.33	.00	123.67	75.1%
<u>10013500 403100 PROFESSIONAL SERVI</u>	44,333	11,474	55,807	1,088.00	.00	54,719.00	1.9%
<u>10013500 403600 ADVERTISING</u>	600	0	600	94.60	.00	505.40	15.8%
<u>10013500 405510 MILEAGE ALLOWANCES</u>	100	0	100	.00	.00	100.00	.0%
<u>10013500 406001 OFFICE SUPPLIES</u>	100	0	100	21.07	.00	78.93	21.1%
<u>10013500 408102 FURNITURE & FIXTUR</u>	250	0	250	.00	.00	250.00	.0%
TOTAL REASSESSMENT	52,380	11,474	63,854	6,457.00	.00	57,397.00	10.1%



10/30/2018 14:34
5311epol

COUNTY OF FLUVANNA
FY18 Q4 YEAR-TO-DATE BUDGET REPORT

P 6
glytdbud

FOR 2018 12

ACCOUNTS FOR: 100	GENERAL FUND	ORIGINAL APPROP	TRANFRS/ ADJSTMTS	REVISED BUDGET	YTD EXPENDED	ENCUMBRANCES	AVAILABLE BUDGET	PCT USED
140 TREASURER								
10014000	401100	FULL-TIME SALARIES	275,455	0	275,455	264,352.34	.00	11,102.66 96.0%
10014000	402100	FICA	21,072	0	21,072	18,750.12	.00	2,321.88 89.0%
10014000	402210	VRS	23,606	0	23,606	22,152.61	.00	1,453.39 93.8%
10014000	402250	DISABILITY	0	460	460	457.01	.00	2.99 99.4%
10014000	402300	MEDICAL INSURANCE	47,940	-3,573	44,367	44,367.00	.00	.00 100.0%
10014000	402400	GROUP LIFE	3,608	0	3,608	3,477.56	.00	130.44 96.4%
10014000	402700	WORKER'S COMPENSAT	248	0	248	220.86	.00	27.14 89.1%
10014000	403100	PROFESSIONAL SERVI	13,000	0	13,000	2,802.50	.00	10,197.50 21.6%
10014000	403500	PRINTING AND BINDI	12,400	0	12,400	6,297.65	.00	6,102.35 50.8%
10014000	403600	ADVERTISING	500	0	500	378.00	.00	122.00 75.6%
10014000	403650	BANK FEES AND CHAR	0	4,745	4,745	38,867.13	.00	-34,122.13 819.1%*
10014000	404102	DMV DMV-ONLINE	16,700	0	16,700	12,980.00	.00	3,720.00 77.7%
10014000	405210	POSTAL SERVICES	22,500	0	22,500	30,348.87	.00	-7,848.87 134.9%*
10014000	405230	TELECOMMUNICATIONS	1,300	0	1,300	831.61	.00	468.39 64.0%
10014000	405410	LEASE/RENT	7,920	0	7,920	3,657.01	.00	4,262.99 46.2%
10014000	405530	SUBSISTENCE & LODG	1,000	0	1,000	.00	.00	1,000.00 .0%
10014000	405540	CONVENTION AND EDU	1,500	0	1,500	.00	.00	1,500.00 .0%
10014000	405810	DUES OR ASSOCIATIO	900	0	900	.00	.00	900.00 .0%
10014000	406001	OFFICE SUPPLIES	4,500	0	4,500	4,252.78	.00	247.22 94.5%
10014000	408102	FURNITURE & FIXTUR	500	3,925	4,425	4,424.79	.00	.21 100.0%
10014000	408107	EDP EQUIPMENT	1,600	0	1,600	3,182.08	.00	-1,582.08 198.9%*
TOTAL TREASURER			456,249	5,557	461,806	461,799.92	.00	6.08 100.0%



10/30/2018 14:34
5311epol

COUNTY OF FLUVANNA
FY18 Q4 YEAR-TO-DATE BUDGET REPORT

P 7
glytdbud

FOR 2018 12

ACCOUNTS FOR: 100 GENERAL FUND	ORIGINAL APPROP	TRANFRS/ ADJSTMTS	REVISED BUDGET	YTD EXPENDED	ENCUMBRANCES	AVAILABLE BUDGET	PCT USED
150 INFORMATION TECHNOLOGY							
10015000 401100 FULL-TIME SALARIES	107,231	-2,149	105,082	105,082.07	.00	-.07	100.0%*
10015000 401310 OVERTIME PAY	1,000	0	1,000	245.76	.00	754.24	24.6%
10015000 402100 FICA	8,280	-164	8,116	7,940.10	.00	175.90	97.8%
10015000 402210 VRS	9,190	-211	8,979	8,860.07	.00	118.93	98.7%
10015000 402250 DISABILITY	0	0	0	231.65	.00	-231.65	100.0%*
10015000 402300 MEDICAL INSURANCE	6,120	360	6,480	5,428.43	.00	1,051.57	83.8%
10015000 402400 GROUP LIFE	1,405	-32	1,373	1,354.34	.00	18.66	98.6%
10015000 402700 WORKER'S COMPENSAT	97	0	97	82.19	.00	14.81	84.7%
10015000 403100 PROFESSIONAL SERVI	9,000	0	9,000	11,542.12	.00	-2,542.12	128.2%*
10015000 403131 ADP SERVICES	195,570	0	195,570	197,446.16	.00	-1,876.16	101.0%*
10015000 403600 ADVERTISING	0	0	0	104.20	.00	-104.20	100.0%*
10015000 405230 TELECOMMUNICATIONS	29,850	0	29,850	31,344.14	.00	-1,494.14	105.0%*
10015000 405410 LEASE/RENT	250	0	250	375.00	.00	-125.00	150.0%*
10015000 405510 MILEAGE ALLOWANCES	200	0	200	.00	.00	200.00	.0%
10015000 405540 CONVENTION AND EDU	2,000	0	2,000	976.88	.00	1,023.12	48.8%
10015000 405810 DUES OR ASSOCIATIO	500	0	500	99.00	.00	401.00	19.8%
10015000 406001 OFFICE SUPPLIES	200	0	200	63.38	.00	136.62	31.7%
10015000 406012 BOOKS/PUBLICATIONS	1,000	0	1,000	278.10	.00	721.90	27.8%
10015000 406021 ADP SUPPLIES	9,000	0	9,000	8,523.48	.00	476.52	94.7%
10015000 408102 FURNITURE & FIXTUR	1,000	0	1,000	795.54	.00	204.46	79.6%
10015000 408107 EDP EQUIPMENT	31,200	0	31,200	29,831.69	.00	1,368.31	95.6%
TOTAL INFORMATION TECHNOLOGY	413,093	-2,196	410,897	410,604.30	.00	292.70	99.9%



10/30/2018 14:34
5311epol

COUNTY OF FLUVANNA
FY18 Q4 YEAR-TO-DATE BUDGET REPORT

P 8
glytddbud

FOR 2018 12

ACCOUNTS FOR: 100 GENERAL FUND	ORIGINAL APPROP	TRANFRS/ ADJSTMTS	REVISED BUDGET	YTD EXPENDED	ENCUMBRANCES	AVAILABLE BUDGET	PCT USED
160 FINANCE							
10016000 401100 FULL-TIME SALARIES	251,336	8,112	259,448	255,709.97	.00	3,738.03	98.6%
10016000 402100 FICA	19,227	621	19,848	17,986.07	.00	1,861.93	90.6%
10016000 402210 VRS	21,539	695	22,234	21,824.10	.00	409.90	98.2%
10016000 402250 DISABILITY	967	0	967	729.66	.00	237.34	75.5%
10016000 402300 MEDICAL INSURANCE	35,700	8,039	43,739	42,891.00	.00	848.00	98.1%
10016000 402400 GROUP LIFE	3,293	106	3,399	3,336.04	.00	62.96	98.1%
10016000 402700 WORKER'S COMPENSAT	226	0	226	192.65	.00	33.35	85.2%
10016000 403100 PROFESSIONAL SERVI	2,000	0	2,000	1,920.00	.00	80.00	96.0%
10016000 403300 CONTRACT SERVICES	725	0	725	784.00	.00	-59.00	108.1%*
10016000 403305 SURPLUS COSTS	200	0	200	.00	.00	200.00	.0%
10016000 403500 PRINTING AND BINDI	100	0	100	.00	.00	100.00	.0%
10016000 403600 ADVERTISING	300	0	300	.00	.00	300.00	.0%
10016000 405210 POSTAL SERVICES	2,000	0	2,000	2,281.24	.00	-281.24	114.1%*
10016000 405230 TELECOMMUNICATIONS	600	0	600	323.28	.00	276.72	53.9%
10016000 405410 LEASE/RENT	3,000	0	3,000	2,048.37	.00	951.63	68.3%
10016000 405510 MILEAGE ALLOWANCES	200	0	200	.00	.00	200.00	.0%
10016000 405530 SUBSISTENCE & LODG	1,800	0	1,800	.00	.00	1,800.00	.0%
10016000 405540 CONVENTION AND EDU	2,675	0	2,675	450.00	.00	2,225.00	16.8%
10016000 405810 DUES OR ASSOCIATIO	1,020	0	1,020	1,280.00	.00	-260.00	125.5%*
10016000 406001 OFFICE SUPPLIES	2,500	-101	2,399	2,043.52	.00	355.48	85.2%
10016000 406012 BOOKS/PUBLICATIONS	100	0	100	.00	.00	100.00	.0%
10016000 408102 FURNITURE & FIXTUR	300	0	300	166.99	.00	133.01	55.7%
TOTAL FINANCE	349,808	17,472	367,280	353,966.89	.00	13,313.11	96.4%



10/30/2018 14:34
5311epol

COUNTY OF FLUVANNA
FY18 Q4 YEAR-TO-DATE BUDGET REPORT

P 9
glytddb

FOR 2018 12

ACCOUNTS FOR: 100 GENERAL FUND	ORIGINAL APPROP	TRANFRS/ ADJSTMTS	REVISED BUDGET	YTD EXPENDED	ENCUMBRANCES	AVAILABLE BUDGET	PCT USED
170 REGISTRAR/ELECTORAL BOARD							
10017000 401100 FULL-TIME SALARIES	56,724	766	57,490	57,548.04	.00	-58.04	100.1%*
10017000 401114 BOARD COMPENSATION	8,424	0	8,424	8,579.10	.00	-155.10	101.8%*
10017000 401300 PART-TIME SALARIES	39,564	0	39,564	37,228.65	.00	2,335.35	94.1%
10017000 401310 OVERTIME PAY	0	0	0	702.76	.00	-702.76	100.0%*
10017000 402100 FICA	8,010	59	8,069	7,843.13	.00	225.87	97.2%
10017000 402210 VRS	7,357	66	7,423	6,834.09	.00	588.91	92.1%
10017000 402250 DISABILITY	127	0	127	145.20	.00	-18.20	114.3%*
10017000 402300 MEDICAL INSURANCE	12,240	-528	11,712	11,712.00	.00	.00	100.0%
10017000 402400 GROUP LIFE	1,125	10	1,135	1,073.46	.00	61.54	94.6%
10017000 402700 WORKER'S COMPENSAT	87	0	87	56.58	.00	30.42	65.0%
10017000 403100 PROFESSIONAL SERVI	0	0	0	56.30	.00	-56.30	100.0%*
10017000 403300 CONTRACT SERVICES	56,394	3,200	59,594	38,084.20	.00	21,509.80	63.9%
10017000 403600 ADVERTISING	300	0	300	63.00	.00	237.00	21.0%
10017000 405210 POSTAL SERVICES	2,000	0	2,000	1,766.47	.00	233.53	88.3%
10017000 405230 TELECOMMUNICATIONS	1,240	0	1,240	1,647.29	.00	-407.29	132.8%*
10017000 405410 LEASE/RENT	2,580	0	2,580	3,713.79	.00	-1,133.79	143.9%*
10017000 405510 MILEAGE ALLOWANCES	1,000	0	1,000	923.05	.00	76.95	92.3%
10017000 405530 SUBSISTENCE & LODG	2,400	0	2,400	476.17	.00	1,923.83	19.8%
10017000 405540 CONVENTION AND EDU	2,500	0	2,500	1,056.16	.00	1,443.84	42.2%
10017000 405810 DUES OR ASSOCIATIO	455	0	455	560.00	.00	-105.00	123.1%*
10017000 406001 OFFICE SUPPLIES	3,800	0	3,800	1,582.86	.00	2,217.14	41.7%
10017000 408101 MACHINERY AND EQUI	8,000	0	8,000	5,448.96	.00	2,551.04	68.1%
TOTAL REGISTRAR/ELECTORAL BOARD	214,327	3,573	217,900	187,101.26	.00	30,798.74	85.9%



10/30/2018 14:34
5311epol

COUNTY OF FLUVANNA
FY18 Q4 YEAR-TO-DATE BUDGET REPORT

P 10
glytdbud

FOR 2018 12

ACCOUNTS FOR: 100 GENERAL FUND	ORIGINAL APPROP	TRANFRS/ ADJSTMTS	REVISED BUDGET	YTD EXPENDED	ENCUMBRANCES	AVAILABLE BUDGET	PCT USED
180 HUMAN RESOURCES							
10018000 401100 FULL-TIME SALARIES	62,166	9,893	72,059	72,059.03	.00	-.03	100.0%*
10018000 402100 FICA	4,756	757	5,513	5,294.20	.00	218.80	96.0%
10018000 402210 VRS	5,328	848	6,176	5,397.88	.00	778.12	87.4%
10018000 402300 MEDICAL INSURANCE	6,540	588	7,128	7,128.22	.00	-.22	100.0%*
10018000 402400 GROUP LIFE	814	130	944	825.04	.00	118.96	87.4%
10018000 402700 WORKER'S COMPENSAT	56	0	56	47.65	.00	8.35	85.1%
10018000 403100 PROFESSIONAL SERVI	19,500	3,000	22,500	17,971.86	.00	4,528.14	79.9%
10018000 405230 TELECOMMUNICATIONS	300	0	300	28.16	.00	271.84	9.4%
10018000 405350 RECRUITMENT	2,310	0	2,310	1,442.55	.00	867.45	62.4%
10018000 405360 EMPLOYEE RECOGNITI	7,000	-2,358	4,642	5,573.88	.00	-931.88	120.1%*
10018000 405410 LEASE/RENT	550	0	550	582.99	.00	-32.99	106.0%*
10018000 405510 MILEAGE ALLOWANCES	100	0	100	.00	.00	100.00	.0%
10018000 405530 SUBSISTENCE & LODG	450	0	450	.00	.00	450.00	.0%
10018000 405540 CONVENTION AND EDU	500	0	500	388.00	.00	112.00	77.6%
10018000 405810 DUES OR ASSOCIATIO	410	0	410	310.00	.00	100.00	75.6%
10018000 406001 OFFICE SUPPLIES	500	0	500	556.65	.00	-56.65	111.3%*
10018000 406012 BOOKS/PUBLICATIONS	130	0	130	.00	.00	130.00	.0%
10018000 408102 FURNITURE & FIXTUR	0	0	0	99.99	.00	-99.99	100.0%*
TOTAL HUMAN RESOURCES	111,410	12,858	124,268	117,706.10	.00	6,561.90	94.7%



10/30/2018 14:34
5311epol

COUNTY OF FLUVANNA
FY18 Q4 YEAR-TO-DATE BUDGET REPORT

P 11
glytdbud

FOR 2018 12

ACCOUNTS FOR: 100 GENERAL FUND	ORIGINAL APPROP	TRANFRS/ ADJSTMTS	REVISED BUDGET	YTD EXPENDED	ENCUMBRANCES	AVAILABLE BUDGET	PCT USED
210 GENERAL DISTRICT COURT							
10021000 403320 MAINTENANCE CONTRA	3,195	0	3,195	3,291.06	.00	-96.06	103.0%*
10021000 405230 TELECOMMUNICATIONS	4,000	0	4,000	2,753.71	.00	1,246.29	68.8%
10021000 405410 LEASE/RENT	112	0	112	180.00	.00	-68.00	160.7%*
10021000 405510 MILEAGE ALLOWANCES	150	0	150	.00	.00	150.00	.0%
10021000 405540 CONVENTION AND EDU	500	0	500	.00	.00	500.00	.0%
10021000 405810 DUES OR ASSOCIATIO	75	0	75	.00	.00	75.00	.0%
10021000 406001 OFFICE SUPPLIES	1,500	0	1,500	1,474.34	.00	25.66	98.3%
TOTAL GENERAL DISTRICT COURT	9,532	0	9,532	7,699.11	.00	1,832.89	80.8%



10/30/2018 14:34
5311epol

COUNTY OF FLUVANNA
FY18 Q4 YEAR-TO-DATE BUDGET REPORT

P 12
glytdbud

FOR 2018 12

ACCOUNTS FOR: 100 GENERAL FUND	ORIGINAL APPROP	TRANFRS/ ADJSTMTS	REVISED BUDGET	YTD EXPENDED	ENCUMBRANCES	AVAILABLE BUDGET	PCT USED
220 COURT SERVICE UNIT							
10022000 405210 POSTAL SERVICES	210	0	210	215.00	.00	-5.00	102.4%*
10022000 405230 TELECOMMUNICATIONS	800	0	800	227.79	.00	572.21	28.5%
10022000 405410 LEASE/RENT	250	0	250	149.78	.00	100.22	59.9%
10022000 405510 MILEAGE ALLOWANCES	600	0	600	915.13	.00	-315.13	152.5%*
10022000 405540 CONVENTION AND EDU	300	0	300	115.04	.00	184.96	38.3%
10022000 406001 OFFICE SUPPLIES	700	0	700	148.60	.00	551.40	21.2%
10022000 408102 FURNITURE & FIXTUR	0	6,519	6,519	6,518.61	.00	.39	100.0%
TOTAL COURT SERVICE UNIT	2,860	6,519	9,379	8,289.95	.00	1,089.05	88.4%



10/30/2018 14:34
5311epol

COUNTY OF FLUVANNA
FY18 Q4 YEAR-TO-DATE BUDGET REPORT

P 13
glytddb

FOR 2018 12

ACCOUNTS FOR: 100	GENERAL FUND	ORIGINAL APPROP	TRANFRS/ ADJSTMTS	REVISED BUDGET	YTD EXPENDED	ENCUMBRANCES	AVAILABLE BUDGET	PCT USED
230 CLERK OF THE CIRCUIT COURT								
10023000	401100	FULL-TIME SALARIES	390,310	4,244	394,554	394,553.99	.00	.01 100.0%
10023000	401310	OVERTIME PAY	2,000	0	2,000	663.61	.00	1,336.39 33.2%
10023000	401320	HOLIDAY & DISCRETI	0	0	0	1,056.60	.00	-1,056.60 100.0%*
10023000	402100	FICA	30,012	325	30,337	28,168.11	.00	2,168.89 92.9%
10023000	402210	VRS	33,450	337	33,787	32,938.45	.00	848.55 97.5%
10023000	402250	DISABILITY	1,093	0	1,093	1,125.72	.00	-32.72 103.0%*
10023000	402300	MEDICAL INSURANCE	69,780	-6,747	63,033	62,779.92	.00	253.08 99.6%
10023000	402400	GROUP LIFE	5,113	51	5,164	5,164.08	.00	-.08 100.0%*
10023000	402700	WORKER'S COMPENSAT	351	0	351	299.17	.00	51.83 85.2%
10023000	403100	PROFESSIONAL SERVI	38,300	5,595	43,895	39,846.34	.00	4,048.66 90.8%
10023000	403140	TFND TECHNOLOGY TR	7,500	0	7,500	7,017.50	.00	482.50 93.6%
10023000	403150	RECPR RECORD PRESER	20,000	0	20,000	10,999.00	.00	9,001.00 55.0%
10023000	403300	CONTRACT SERVICES	1,500	-250	1,250	197.13	.00	1,052.87 15.8%
10023000	403310	BLDGS EQUIP REP &	500	0	500	105.00	.00	395.00 21.0%
10023000	403320	MAINTENANCE CONTRA	1,400	0	1,400	1,213.00	.00	187.00 86.6%
10023000	403500	PRINTING AND BINDI	3,000	0	3,000	598.72	.00	2,401.28 20.0%
10023000	405210	POSTAL SERVICES	5,000	0	5,000	3,000.00	.00	2,000.00 60.0%
10023000	405230	TELECOMMUNICATIONS	1,500	0	1,500	386.01	.00	1,113.99 25.7%
10023000	405410	LEASE/RENT	3,500	0	3,500	3,344.26	.00	155.74 95.6%
10023000	405510	MILEAGE ALLOWANCES	750	250	1,000	1,046.88	.00	-46.88 104.7%*
10023000	405540	CONVENTION AND EDU	1,000	1,405	2,405	2,289.96	.00	115.04 95.2%
10023000	405810	DUES OR ASSOCIATIO	500	0	500	495.00	.00	5.00 99.0%
10023000	406001	OFFICE SUPPLIES	7,000	0	7,000	5,257.94	.00	1,742.06 75.1%
10023000	406012	BOOKS/PUBLICATIONS	300	0	300	8.75	.00	291.25 2.9%
10023000	408102	FURNITURE & FIXTUR	1,000	19,000	20,000	7,151.99	.00	12,848.01 35.8%
10023000	408107	EDP EQUIPMENT	2,500	0	2,500	2,315.53	.00	184.47 92.6%
TOTAL CLERK OF THE CIRCUIT COURT			627,359	24,210	651,569	612,022.66	.00	39,546.34 93.9%



10/30/2018 14:34
5311epol

COUNTY OF FLUVANNA
FY18 Q4 YEAR-TO-DATE BUDGET REPORT

P 14
glytdbud

FOR 2018 12

ACCOUNTS FOR: 100 GENERAL FUND	ORIGINAL APPROP	TRANFRS/ ADJSTMTS	REVISED BUDGET	YTD EXPENDED	ENCUMBRANCES	AVAILABLE BUDGET	PCT USED
235 CIRCUIT COURT JUDGE							
10023500 401115 COMPENSATION-JUROR	10,800	0	10,800	3,420.00	.00	7,380.00	31.7%
10023500 401116 COMPENSATION-JURY	180	0	180	180.00	.00	.00	100.0%
10023500 401117 COMPENSATION-CIVIL	4,500	0	4,500	2,040.00	.00	2,460.00	45.3%
10023500 401118 COMPENSATION-GRAND	1,260	0	1,260	1,140.00	.00	120.00	90.5%
10023500 401119 COMPENSATION-WITNE	1,500	0	1,500	262.69	.00	1,237.31	17.5%
10023500 401120 COURT APPOINTED AT	500	0	500	158.00	.00	342.00	31.6%
10023500 403100 PROFESSIONAL SERVI	21,000	0	21,000	20,448.40	.00	551.60	97.4%
10023500 405230 TELECOMMUNICATIONS	450	0	450	92.21	.00	357.79	20.5%
10023500 405810 DUES OR ASSOCIATIO	150	0	150	.00	.00	150.00	.0%
10023500 406001 OFFICE SUPPLIES	750	0	750	460.90	.00	289.10	61.5%
10023500 408101 MACHINERY AND EQUI	0	12,193	12,193	12,193.00	.00	.00	100.0%
10023500 408102 FURNITURE & FIXTUR	2,500	0	2,500	2,401.00	.00	99.00	96.0%
10023500 408107 EDP EQUIPMENT	2,500	-524	1,976	1,821.45	.00	154.55	92.2%
TOTAL CIRCUIT COURT JUDGE	46,090	11,669	57,759	44,617.65	.00	13,141.35	77.2%



10/30/2018 14:34
5311epol

COUNTY OF FLUVANNA
FY18 Q4 YEAR-TO-DATE BUDGET REPORT

P 15
glytddb

FOR 2018 12

ACCOUNTS FOR: 100 GENERAL FUND	ORIGINAL APPROP	TRANFRS/ ADJSTMTS	REVISED BUDGET	YTD EXPENDED	ENCUMBRANCES	AVAILABLE BUDGET	PCT USED
240 COMMONWEALTHS ATTORNEY							
10024000 401100 FULL-TIME SALARIES	304,232	333	304,565	294,816.97	.00	9,748.03	96.8%
10024000 401100 VICWT FULL-TIME SAL	49,115	491	49,606	49,606.44	.00	-.44	100.0%*
10024000 401300 PART-TIME SALARIES	0	667	667	666.66	.00	.34	99.9%
10024000 401320 HOLIDAY & DISCRETI	0	0	0	198.99	.00	-198.99	100.0%*
10024000 402100 FICA	23,274	77	23,351	20,963.98	.00	2,387.02	89.8%
10024000 402100 VICWT FICA	3,757	38	3,795	3,669.79	.00	125.21	96.7%
10024000 402210 VRS	26,073	0	26,073	25,199.32	.00	873.68	96.6%
10024000 402210 VICWT VRS	4,209	42	4,251	4,142.16	.00	108.84	97.4%
10024000 402250 DISABILITY	0	0	0	508.77	.00	-508.77	100.0%*
10024000 402300 MEDICAL INSURANCE	42,840	-2,549	40,291	40,038.00	.00	253.00	99.4%
10024000 402300 VICWT MEDICAL INSUR	6,120	-264	5,856	5,856.00	.00	.00	100.0%
10024000 402400 GROUP LIFE	3,985	0	3,985	3,953.46	.00	31.54	99.2%
10024000 402400 VICWT GROUP LIFE	643	6	649	649.80	.00	-.80	100.1%*
10024000 402700 WORKER'S COMPENSAT	318	0	318	270.84	.00	47.16	85.2%
10024000 403300 CONTRACT SERVICES	0	1,500	1,500	1,599.00	.00	-99.00	106.6%*
10024000 403320 MAINTENANCE CONTRA	6,075	-200	5,875	5,394.49	.00	480.51	91.8%
10024000 405210 POSTAL SERVICES	900	-200	700	550.17	.00	149.83	78.6%
10024000 405230 TELECOMMUNICATIONS	1,700	0	1,700	878.96	.00	821.04	51.7%
10024000 405410 LEASE/RENT	936	-200	736	267.56	.00	468.44	36.4%
10024000 405510 MILEAGE ALLOWANCES	0	0	0	60.60	.00	-60.60	100.0%*
10024000 405530 SUBSISTENCE & LODG	0	0	0	342.86	.00	-342.86	100.0%*
10024000 405540 CONVENTION AND EDU	5,404	0	5,404	4,488.67	.00	915.33	83.1%
10024000 405810 DUES OR ASSOCIATIO	1,410	0	1,410	1,676.00	.00	-266.00	118.9%*
10024000 406001 OFFICE SUPPLIES	4,000	380	4,380	4,882.86	.00	-502.86	111.5%*
10024000 406012 BOOKS/PUBLICATIONS	4,124	-300	3,824	2,688.91	.00	1,135.09	70.3%
10024000 406014 VICWT OTHER OPERATI	0	5,629	5,629	3,452.14	.00	2,176.86	61.3%
10024000 408102 FURNITURE & FIXTUR	1,500	-980	520	.00	.00	520.00	.0%
10024000 408107 EDP EQUIPMENT	250	0	250	.00	.00	250.00	.0%
TOTAL COMMONWEALTHS ATTORNEY	490,865	4,470	495,335	476,823.40	.00	18,511.60	96.3%



10/30/2018 14:34
5311epol

COUNTY OF FLUVANNA
FY18 Q4 YEAR-TO-DATE BUDGET REPORT

P 16
glytdbud

FOR 2018 12

ACCOUNTS FOR: 100	GENERAL FUND	ORIGINAL APPROP	TRANFRS/ ADJSTMTS	REVISED BUDGET	YTD EXPENDED	ENCUMBRANCES	AVAILABLE BUDGET	PCT USED
310 SHERIFF								
10031000	401100	FULL-TIME SALARIES	1,650,785	-3,044	1,647,741	1,635,867.05	.00	11,873.76 99.3%
10031000	401300	PART-TIME SALARIES	46,786	0	46,786	30,768.34	.00	16,017.66 65.8%
10031000	401310	OVERTIME PAY	50,000	7,000	57,000	48,532.27	.00	8,467.73 85.1%
10031000	401320	HOLIDAY & DISCRETI	44,000	13,000	57,000	68,151.49	.00	-11,151.49 119.6%*
10031000	401325	CONTRACTUAL WAGES	30,000	0	30,000	27,682.50	.00	2,317.50 92.3%
10031000	402100	FICA	138,891	0	138,891	131,804.14	.00	7,086.86 94.9%
10031000	402210	VRS	140,958	0	140,958	134,443.65	.00	6,514.35 95.4%
10031000	402300	MEDICAL INSURANCE	250,980	3,779	254,759	254,440.55	.00	318.45 99.9%
10031000	402400	GROUP LIFE	21,547	0	21,547	21,078.76	.00	468.24 97.8%
10031000	402700	WORKER'S COMPENSAT	39,554	0	39,554	34,420.16	.00	5,133.84 87.0%
10031000	402750	LINE OF DUTY	11,750	0	11,750	8,768.94	.00	2,981.06 74.6%
10031000	402810	CLOTHING ALLOWANCE	2,800	0	2,800	2,800.00	.00	.00 100.0%
10031000	403100	PROFESSIONAL SERVI	1,496	1,500	2,996	3,545.25	.00	-549.25 118.3%*
10031000	403164	COMMUNITY EDUCATIO	5,000	0	5,000	4,810.05	.00	189.95 96.2%
10031000	403190	INVESTIGATIVE SERV	2,238	2,974	5,212	5,246.30	.00	-34.30 100.7%*
10031000	403300	CONTRACT SERVICES	5,325	0	5,325	3,187.10	.00	2,137.90 59.9%
10031000	403310	BLDGS EQUIP REP &	3,200	0	3,200	.00	.00	3,200.00 .0%
10031000	403315	VEHICLES REP & MAI	30,000	3,907	33,907	36,601.04	.00	-2,693.94 107.9%*
10031000	403320	MAINTENANCE CONTRA	18,700	0	18,700	22,177.73	.00	-3,477.73 118.6%*
10031000	403600	ADVERTISING	1,000	0	1,000	290.00	.00	710.00 29.0%
10031000	405210	POSTAL SERVICES	2,200	0	2,200	2,834.18	.00	-634.18 128.8%*
10031000	405230	TELECOMMUNICATIONS	43,061	0	43,061	43,522.99	.00	-461.99 101.1%*
10031000	405305	VEHICLE INSURANCE	21,000	0	21,000	21,973.50	.00	-973.50 104.6%*
10031000	405310	VOLUNTEER ACCIDENT	1,000	0	1,000	1,000.00	.00	.00 100.0%
10031000	405410	LEASE/RENT	4,615	0	4,615	3,968.33	.00	646.67 86.0%
10031000	405530	SUBSISTENCE & LODG	7,000	2,137	9,137	9,388.26	.00	-251.26 102.7%*
10031000	405540	CONVENTION AND EDU	40,000	0	40,000	40,606.33	.00	-606.33 101.5%*
10031000	405550	EXTRADITION OF PRI	1,000	0	1,000	52.17	.00	947.83 5.2%
10031000	405810	DUES OR ASSOCIATIO	2,200	0	2,200	2,255.00	.00	-55.00 102.5%*
10031000	406001	OFFICE SUPPLIES	8,500	4,107	12,607	13,832.94	.00	-1,225.85 109.7%*
10031000	406002	FOOD SUPPLIES	500	0	500	477.72	.00	22.28 95.5%
10031000	406008	VEHICLE FUEL	60,000	0	60,000	65,910.70	.00	-5,910.70 109.9%*
10031000	406009	VEHICLE/POWER EQUI	24,303	0	24,303	25,429.01	.00	-1,126.01 104.6%*
10031000	406010	POLICE SUPPLIES	31,433	18,677	50,110	49,944.78	.00	165.32 99.7%
10031000	406011	UNIFORM/WEARING AP	16,300	0	16,300	15,018.86	.00	1,281.14 92.1%
10031000	406011	BPVST UNIFORM/WEARI	5,500	0	5,500	7,529.24	.00	-2,029.24 136.9%*
10031000	406014	OTHER OPERATING SU	3,500	0	3,500	1,240.48	.00	2,259.52 35.4%
10031000	406014	16VOL OTHER OPERATI	1,500	1,493	2,993	1,979.36	.00	1,013.84 66.1%
10031000	408101	MACHINERY AND EQUI	2,500	0	2,500	2,715.00	.00	-215.00 108.6%*
10031000	408102	FURNITURE & FIXTUR	1,500	0	1,500	2,876.66	.00	-1,376.66 191.8%*



10/30/2018 14:34
5311epol

COUNTY OF FLUVANNA
FY18 Q4 YEAR-TO-DATE BUDGET REPORT

P 17
glytdbud

FOR 2018 12

ACCOUNTS FOR: 100 GENERAL FUND	ORIGINAL APPROP	TRANFRS/ ADJSTMTS	REVISED BUDGET	YTD EXPENDED	ENCUMBRANCES	AVAILABLE BUDGET	PCT USED
10031000 408103 COMMUNICATIONS EQU	2,000	0	2,000	1,104.76	.00	895.24	55.2%
TOTAL SHERIFF	2,774,622	55,530	2,830,152	2,788,275.59	.00	41,876.71	98.5%



10/30/2018 14:34
5311epol

COUNTY OF FLUVANNA
FY18 Q4 YEAR-TO-DATE BUDGET REPORT

P 18
glytddbud

FOR 2018 12

ACCOUNTS FOR: 100 GENERAL FUND	ORIGINAL APPROP	TRANFRS/ ADJSTMTS	REVISED BUDGET	YTD EXPENDED	ENCUMBRANCES	AVAILABLE BUDGET	PCT USED
320 E911							
10032000 401100 FULL-TIME SALARIES	539,309	5,633	544,942	544,540.92	.00	401.08	99.9%
10032000 401300 PART-TIME SALARIES	18,688	0	18,688	12,071.05	.00	6,616.95	64.6%
10032000 401310 OVERTIME PAY	23,167	15,000	38,167	29,700.41	.00	8,466.59	77.8%
10032000 401320 HOLIDAY & DISCRETI	20,851	10,000	30,851	43,346.86	.00	-12,495.86	140.5%*
10032000 402100 FICA	46,054	431	46,485	45,819.51	.00	665.49	98.6%
10032000 402210 VRS	46,219	482	46,701	43,803.36	.00	2,897.64	93.8%
10032000 402250 DISABILITY	1,011	0	1,011	1,371.50	.00	-360.50	135.7%*
10032000 402300 MEDICAL INSURANCE	84,180	20,398	104,578	104,448.79	.00	129.21	99.9%
10032000 402400 GROUP LIFE	7,065	74	7,139	6,872.52	.00	266.48	96.3%
10032000 402700 WORKER'S COMPENSAT	502	0	502	435.05	.00	66.95	86.7%
10032000 403125 IT SERVICES	64,000	0	64,000	56,324.58	.00	7,675.42	88.0%
10032000 403161 E911 NEW ROAD SIGN	16,006	0	16,006	7,259.25	.00	8,746.75	45.4%
10032000 403310 BLDGS EQUIP REP &	21,081	0	21,081	20,647.18	.00	433.82	97.9%
10032000 403320 E911O MAINTENANCE C	69,794	0	69,794	42,685.56	.00	27,108.44	61.2%
10032000 405230 TELECOMMUNICATIONS	70,000	0	70,000	36,365.68	.00	33,634.32	52.0%
10032000 405410 LEASE/RENT	1,320	0	1,320	932.76	.00	387.24	70.7%
10032000 405510 MILEAGE ALLOWANCES	300	0	300	76.30	.00	223.70	25.4%
10032000 405530 SUBSISTENCE & LODG	2,000	0	2,000	430.83	.00	1,569.17	21.5%
10032000 405540 CONVENTION AND EDU	2,000	0	2,000	-81.00	.00	2,081.00	-4.1%
10032000 405540 12WEP CONVENTION AN	0	2,000	2,000	2,161.53	.00	-161.53	108.1%*
10032000 405810 DUES OR ASSOCIATIO	500	0	500	416.00	.00	84.00	83.2%
10032000 406001 OFFICE SUPPLIES	2,000	0	2,000	1,608.59	.00	391.41	80.4%
10032000 406011 UNIFORM/WEARING AP	1,200	0	1,200	1,169.50	.00	30.50	97.5%
10032000 408102 FURNITURE & FIXTUR	0	0	0	365.86	.00	-365.86	100.0%*
10032000 408107 EDP EQUIPMENT	3,600	0	3,600	4,698.73	.00	-1,098.73	130.5%*
TOTAL E911	1,040,847	54,018	1,094,865	1,007,471.32	.00	87,393.68	92.0%



10/30/2018 14:34
5311epol

COUNTY OF FLUVANNA
FY18 Q4 YEAR-TO-DATE BUDGET REPORT

P 19
glytddbud

FOR 2018 12

ACCOUNTS FOR: 100 GENERAL FUND	ORIGINAL APPROP	TRANFRS/ ADJSTMTS	REVISED BUDGET	YTD EXPENDED	ENCUMBRANCES	AVAILABLE BUDGET	PCT USED
325 FIRE AND RESCUE SQUAD							
10032500 402750 LINE OF DUTY	13,000	0	13,000	13,577.04	.00	-577.04	104.4%*
10032500 403315 VEHICLES REP & MAI	0	0	0	1,422.23	.00	-1,422.23	100.0%*
10032500 405305 VEHICLE INSURANCE	52,000	0	52,000	44,330.65	.00	7,669.35	85.3%
10032500 405308 GENERAL LIABILITY	29,500	0	29,500	30,807.00	.00	-1,307.00	104.4%*
10032500 405310 VOLUNTEER ACCIDENT	14,000	0	14,000	12,885.00	.00	1,115.00	92.0%
10032500 405311 F&R WORKERS COMPEN	52,000	0	52,000	54,105.00	.00	-2,105.00	104.0%*
10032500 405540 CONVENTION AND EDU	30,000	0	30,000	20,980.80	.00	9,019.20	69.9%
10032500 405623 SCOTTSVILLE VOLUNT	10,000	0	10,000	10,000.00	.00	.00	100.0%
10032500 405624 SCOTTSVILLE VOL. R	15,000	0	15,000	15,000.00	.00	.00	100.0%
10032500 405625 FIRE & RESCUE ASSN	508,500	61,942	570,442	570,442.15	.00	.00	100.0%
10032500 405626 FIRE & RESCUE CAPI	547,000	0	547,000	372,000.00	.00	175,000.00	68.0%
10032500 405627 STFRE STATE FIRE FU	85,000	889	85,889	85,889.00	.00	.00	100.0%
10032500 405628 24LFE FOUR FOR LIFE	26,000	0	26,000	.00	.00	26,000.00	.0%
TOTAL FIRE AND RESCUE SQUAD	1,382,000	62,831	1,444,831	1,231,438.87	.00	213,392.28	85.2%



10/30/2018 14:34
5311epol

COUNTY OF FLUVANNA
FY18 Q4 YEAR-TO-DATE BUDGET REPORT

P 20
glytdbud

FOR 2018 12

ACCOUNTS FOR: 100 GENERAL FUND	ORIGINAL APPROP	TRANFRS/ ADJSTMTS	REVISED BUDGET	YTD EXPENDED	ENCUMBRANCES	AVAILABLE BUDGET	PCT USED
330 FOREST WARDEN							
<u>10033000 405660 FOREST FIRE SUPPRE</u>	9,012	0	9,012	9,011.97	.00	.03	100.0%
TOTAL FOREST WARDEN	9,012	0	9,012	9,011.97	.00	.03	100.0%



10/30/2018 14:34
5311epol

COUNTY OF FLUVANNA
FY18 Q4 YEAR-TO-DATE BUDGET REPORT

P 21
glytdbud

FOR 2018 12

ACCOUNTS FOR: 100 GENERAL FUND	ORIGINAL APPROP	TRANFRS/ ADJSTMTS	REVISED BUDGET	YTD EXPENDED	ENCUMBRANCES	AVAILABLE BUDGET	PCT USED
335 CORRECTION AND DETENTION							
10033500 401114 BOARD COMPENSATION	2,040	0	2,040	1,870.00	.00	170.00	91.7%
10033500 402100 FICA	156	0	156	120.52	.00	35.48	77.3%
10033500 403840 CONFINEMENT - BRJD	170,614	0	170,614	170,339.04	.00	274.96	99.8%
10033500 406002 FOOD SUPPLIES	250	0	250	33.62	.00	216.38	13.4%
10033500 406014 OTHER OPERATING SU	0	0	0	5.74	.00	-5.74	100.0%*
10033500 407004 CVRJ COST OF PRISO	1,288,121	0	1,288,121	1,288,121.00	.00	.00	100.0%
TOTAL CORRECTION AND DETENTION	1,461,181	0	1,461,181	1,460,489.92	.00	691.08	100.0%



10/30/2018 14:34
5311epol

COUNTY OF FLUVANNA
FY18 Q4 YEAR-TO-DATE BUDGET REPORT

P 22
glytddbud

FOR 2018 12

ACCOUNTS FOR: 100 GENERAL FUND	ORIGINAL APPROP	TRANFRS/ ADJSTMTS	REVISED BUDGET	YTD EXPENDED	ENCUMBRANCES	AVAILABLE BUDGET	PCT USED
340 BUILDING INSPECTIONS							
<u>10034000 401100 FULL-TIME SALARIES</u>	137,700	5,768	143,468	143,467.83	.00	.17	100.0%
<u>10034000 402100 FICA</u>	10,534	441	10,975	10,004.09	.00	970.91	91.2%
<u>10034000 402210 VRS</u>	11,801	467	12,268	12,265.24	.00	2.76	100.0%
<u>10034000 402250 DISABILITY</u>	605	0	605	282.72	.00	322.28	46.7%
<u>10034000 402300 MEDICAL INSURANCE</u>	25,140	3,960	29,100	29,100.00	.00	.00	100.0%
<u>10034000 402400 GROUP LIFE</u>	1,804	71	1,875	1,874.92	.00	.08	100.0%
<u>10034000 402700 WORKER'S COMPENSAT</u>	2,881	0	2,881	2,467.26	.00	413.74	85.6%
<u>10034000 403100 PROFESSIONAL SERVI</u>	650	0	650	.00	.00	650.00	.0%
<u>10034000 403300 CONTRACT SERVICES</u>	1,000	0	1,000	1,000.00	.00	.00	100.0%
<u>10034000 405210 POSTAL SERVICES</u>	400	0	400	78.37	.00	321.63	19.6%
<u>10034000 405230 TELECOMMUNICATIONS</u>	1,700	0	1,700	1,426.46	.00	273.54	83.9%
<u>10034000 405540 CONVENTION AND EDU</u>	750	0	750	976.00	.00	-226.00	130.1%*
<u>10034000 405810 DUES OR ASSOCIATIO</u>	175	0	175	.00	.00	175.00	.0%
<u>10034000 405997 SURCHARGE</u>	3,250	0	3,250	3,759.45	.00	-509.45	115.7%*
<u>10034000 406001 OFFICE SUPPLIES</u>	1,500	0	1,500	704.13	.00	795.87	46.9%
<u>10034000 406008 VEHICLE FUEL</u>	2,700	0	2,700	749.82	.00	1,950.18	27.8%
<u>10034000 406011 UNIFORM/WEARING AP</u>	1,010	0	1,010	.00	.00	1,010.00	.0%
<u>10034000 406012 BOOKS/PUBLICATIONS</u>	1,500	0	1,500	26.70	.00	1,473.30	1.8%
<u>10034000 406014 OTHER OPERATING SU</u>	0	0	0	118.78	.00	-118.78	100.0%*
<u>10034000 408102 FURNITURE & FIXTUR</u>	250	0	250	166.99	.00	83.01	66.8%
TOTAL BUILDING INSPECTIONS	205,350	10,707	216,057	208,468.76	.00	7,588.24	96.5%



10/30/2018 14:34
5311epol

COUNTY OF FLUVANNA
FY18 Q4 YEAR-TO-DATE BUDGET REPORT

P 23
glytddb

FOR 2018 12

ACCOUNTS FOR: 100 GENERAL FUND	ORIGINAL APPROP	TRANFRS/ ADJSTMTS	REVISED BUDGET	YTD EXPENDED	ENCUMBRANCES	AVAILABLE BUDGET	PCT USED
345 EMERGENCY MANAGEMENT							
10034500 401100 FULL-TIME SALARIES	56,560	-10,017	46,543	41,545.18	.00	4,997.82	89.3%
10034500 401300 PART-TIME SALARIES	0	0	0	10,762.50	.00	-10,762.50	100.0%*
10034500 402100 FICA	4,327	-767	3,560	3,980.41	.00	-420.41	111.8%*
10034500 402210 VRS	4,847	-859	3,988	3,357.13	.00	630.87	84.2%
10034500 402250 DISABILITY	0	0	0	150.26	.00	-150.26	100.0%*
10034500 402300 MEDICAL INSURANCE	6,540	-2,342	4,198	4,197.70	.00	.30	100.0%
10034500 402400 GROUP LIFE	741	-131	610	513.14	.00	96.86	84.1%
10034500 402700 WORKER'S COMPENSAT	51	0	51	43.35	.00	7.65	85.0%
10034500 403100 PROFESSIONAL SERVI	160,709	0	160,709	106,646.52	.00	54,062.48	66.4%
10034500 403300 CONTRACT SERVICES	600,000	0	600,000	580,284.06	.00	19,715.94	96.7%
10034500 403300 CSTRC CONTRACT SERV	28,800	0	28,800	31,204.68	.00	-2,404.68	108.3%*
10034500 403500 PRINTING AND BINDI	300	0	300	44.95	.00	255.05	15.0%
10034500 403600 ADVERTISING	1,000	0	1,000	884.40	.00	115.60	88.4%
10034500 405210 POSTAL SERVICES	50	0	50	8.07	.00	41.93	16.1%
10034500 405230 TELECOMMUNICATIONS	720	0	720	870.41	.00	-150.41	120.9%*
10034500 405510 MILEAGE ALLOWANCES	50	0	50	.00	.00	50.00	.0%
10034500 405530 SUBSISTENCE & LODG	500	0	500	.00	.00	500.00	.0%
10034500 405540 CONVENTION AND EDU	4,000	0	4,000	400.00	.00	3,600.00	10.0%
10034500 405810 DUES OR ASSOCIATIO	200	0	200	150.00	.00	50.00	75.0%
10034500 406001 OFFICE SUPPLIES	500	0	500	472.17	.00	27.83	94.4%
10034500 406008 VEHICLE FUEL	1,000	0	1,000	1,188.90	.00	-188.90	118.9%*
10034500 406012 BOOKS/PUBLICATIONS	100	0	100	.00	.00	100.00	.0%
10034500 406020 EMERGENCY SUPPLIES	500	0	500	72.64	.00	427.36	14.5%
TOTAL EMERGENCY MANAGEMENT	871,495	-14,116	857,379	786,776.47	.00	70,602.53	91.8%



10/30/2018 14:34
5311epol

COUNTY OF FLUVANNA
FY18 Q4 YEAR-TO-DATE BUDGET REPORT

P 24
glytdbud

FOR 2018 12

ACCOUNTS FOR: 100 GENERAL FUND	ORIGINAL APPROP	TRANFRS/ ADJSTMTS	REVISED BUDGET	YTD EXPENDED	ENCUMBRANCES	AVAILABLE BUDGET	PCT USED
350 ANIMAL CONTROL							
10035000 401100 FULL-TIME SALARIES	79,511	3,984	83,495	83,494.04	.00	.96	100.0%
10035000 401310 OVERTIME PAY	2,500	0	2,500	1,475.79	.00	1,024.21	59.0%
10035000 401320 HOLIDAY & DISCRETI	0	6,000	6,000	7,409.93	.00	-1,409.93	123.5%*
10035000 402100 FICA	6,274	279	6,553	6,552.45	.00	.55	100.0%
10035000 402210 VRS	6,814	309	7,123	7,122.28	.00	.72	100.0%
10035000 402300 MEDICAL INSURANCE	17,820	1,560	19,380	19,380.00	.00	.00	100.0%
10035000 402400 GROUP LIFE	1,042	0	1,042	1,117.40	.00	-75.40	107.2%*
10035000 402700 WORKER'S COMPENSAT	1,018	0	1,018	893.69	.00	124.31	87.8%
10035000 402750 LINE OF DUTY	710	0	710	515.82	.00	194.18	72.7%
10035000 403100 PROFESSIONAL SERVI	500	1,140	1,640	1,640.35	.00	-.35	100.0%*
10035000 403300 CONTRACT SERVICES	154,750	0	154,750	155,326.00	.00	-576.00	100.4%*
10035000 403315 VEHICLES REP & MAI	4,800	0	4,800	2,262.43	.00	2,537.57	47.1%
10035000 405230 TELECOMMUNICATIONS	2,225	0	2,225	2,110.42	.00	114.58	94.9%
10035000 405305 VEHICLE INSURANCE	1,000	0	1,000	976.60	.00	23.40	97.7%
10035000 405530 SUBSISTENCE & LODG	1,000	0	1,000	968.24	.00	31.76	96.8%
10035000 405540 CONVENTION AND EDU	1,250	0	1,250	2,060.00	.00	-810.00	164.8%*
10035000 405825 PASS-THRU SPAY & N	1,000	0	1,000	.00	.00	1,000.00	.0%
10035000 406001 OFFICE SUPPLIES	500	0	500	455.95	.00	44.05	91.2%
10035000 406003 AGRICULTURAL SUPPL	400	0	400	392.02	.00	7.98	98.0%
10035000 406008 VEHICLE FUEL	5,750	0	5,750	5,083.82	.00	666.18	88.4%
10035000 406009 VEHICLE/POWER EQUI	750	0	750	659.78	.00	90.22	88.0%
10035000 406011 UNIFORM/WEARING AP	1,500	0	1,500	1,584.84	.00	-84.84	105.7%*
TOTAL ANIMAL CONTROL	291,114	13,272	304,386	301,481.85	.00	2,904.15	99.0%



10/30/2018 14:34
5311epol

COUNTY OF FLUVANNA
FY18 Q4 YEAR-TO-DATE BUDGET REPORT

P 25
glytdbud

FOR 2018 12

ACCOUNTS FOR: 100 GENERAL FUND	ORIGINAL APPROP	TRANFRS/ ADJSTMTS	REVISED BUDGET	YTD EXPENDED	ENCUMBRANCES	AVAILABLE BUDGET	PCT USED
410 LITTER							
<u>10041000 403100 ALIED PROFESSIONAL</u>	18,300	0	18,300	18,280.79	.00	19.21	99.9%
<u>10041000 406014 OTHER OPERATING SU</u>	4,969	283	5,252	5,270.56	.00	-18.56	100.4%*
TOTAL LITTER	23,269	283	23,552	23,551.35	.00	.65	100.0%



10/30/2018 14:34
5311epol

COUNTY OF FLUVANNA
FY18 Q4 YEAR-TO-DATE BUDGET REPORT

P 26
glytddbud

FOR 2018 12

ACCOUNTS FOR: 100 GENERAL FUND	ORIGINAL APPROP	TRANFRS/ ADJSTMTS	REVISED BUDGET	YTD EXPENDED	ENCUMBRANCES	AVAILABLE BUDGET	PCT USED
415 FACILITIES							
10041500 401100 FULL-TIME SALARIES	345,743	-8,610	337,133	337,132.73	.00	.27	100.0%
10041500 401300 PART-TIME SALARIES	0	318	318	318.00	.00	.00	100.0%
10041500 401310 OVERTIME PAY	8,000	3,346	11,346	11,345.98	.00	.02	100.0%
10041500 401320 HOLIDAY & DISCRETI	0	0	0	2,161.66	.00	-2,161.66	100.0%*
10041500 402100 FICA	27,055	-1,143	25,912	25,353.85	.00	558.15	97.8%
10041500 402210 VRS	29,624	-1,280	28,344	27,553.49	.00	790.51	97.2%
10041500 402250 DISABILITY	540	0	540	726.57	.00	-186.57	134.6%*
10041500 402300 MEDICAL INSURANCE	78,780	3,580	82,360	81,925.61	.00	434.39	99.5%
10041500 402400 GROUP LIFE	4,528	-196	4,332	4,200.96	.00	131.04	97.0%
10041500 402700 WORKER'S COMPENSAT	6,775	0	6,775	4,799.97	.00	1,975.03	70.8%
10041500 403100 PROFESSIONAL SERVI	0	0	0	2,054.00	.00	-2,054.00	100.0%*
10041500 403300 CONTRACT SERVICES	48,500	0	48,500	15,952.16	.00	32,547.84	32.9%
10041500 403310 BLDGS EQUIP REP &	178,000	71,927	249,927	284,505.11	.00	-34,578.11	113.8%*
10041500 403315 VEHICLES REP & MAI	23,300	0	23,300	21,279.07	.00	2,020.93	91.3%
10041500 403600 ADVERTISING	350	0	350	126.00	.00	224.00	36.0%
10041500 403700 LAUNDRY AND DRY CL	6,500	0	6,500	8,579.89	.00	-2,079.89	132.0%*
10041500 405210 POSTAL SERVICES	350	0	350	248.77	.00	101.23	71.1%
10041500 405230 TELECOMMUNICATIONS	6,000	0	6,000	8,522.97	.00	-2,522.97	142.0%*
10041500 405305 VEHICLE INSURANCE	16,000	0	16,000	12,705.30	.00	3,294.70	79.4%
10041500 405410 LEASE/RENT	1,500	0	1,500	.00	.00	1,500.00	.0%
10041500 405510 MILEAGE ALLOWANCES	250	0	250	809.36	.00	-559.36	323.7%*
10041500 405530 SUBSISTENCE & LODG	2,000	0	2,000	867.91	.00	1,132.09	43.4%
10041500 405540 CONVENTION AND EDU	5,000	0	5,000	128.90	.00	4,871.10	2.6%
10041500 405810 DUES OR ASSOCIATIO	1,000	0	1,000	960.00	.00	40.00	96.0%
10041500 406001 OFFICE SUPPLIES	1,500	0	1,500	618.28	.00	881.72	41.2%
10041500 406003 AGRICULTURAL SUPPL	20,000	0	20,000	2,540.45	.00	17,459.55	12.7%
10041500 406004 GENERAL MATERIALS	27,000	0	27,000	44,910.41	.00	-17,910.41	166.3%*
10041500 406005 JANITORIAL SUPPLIE	18,000	0	18,000	24,286.12	.00	-6,286.12	134.9%*
10041500 406008 VEHICLE FUEL	20,000	0	20,000	19,404.85	.00	595.15	97.0%
10041500 406009 VEHICLE/POWER EQUI	5,000	0	5,000	9,957.79	.00	-4,957.79	199.2%*
10041500 408101 MACHINERY AND EQUI	20,350	0	20,350	12,527.00	.00	7,823.00	61.6%
10041500 408103 COMMUNICATIONS EQU	750	0	750	.00	.00	750.00	.0%
10041500 408109 BUILDING	0	11,520	11,520	11,520.00	.00	.00	100.0%
TOTAL FACILITIES	902,395	79,462	981,857	978,023.16	.00	3,833.84	99.6%



10/30/2018 14:34
5311epol

COUNTY OF FLUVANNA
FY18 Q4 YEAR-TO-DATE BUDGET REPORT

P 27
glytdbud

FOR 2018 12

ACCOUNTS FOR: 100 GENERAL FUND	ORIGINAL APPROP	TRANFRS/ ADJSTMTS	REVISED BUDGET	YTD EXPENDED	ENCUMBRANCES	AVAILABLE BUDGET	PCT USED
420 GENERAL SERVICES							
10042000 403320 MAINTENANCE CONTRA	137,200	-22,500	114,700	114,638.67	.00	61.33	99.9%
10042000 405110 ELECTRICAL SERVICE	225,000	-27,841	197,159	196,559.41	.00	599.59	99.7%
10042000 405120 HEATING SERVICES	100,000	-23,000	77,000	76,674.84	.00	325.16	99.6%
10042000 405130 WATER SERVICES	15,000	-5,000	10,000	6,293.28	.00	3,706.72	62.9%
10042000 405135 SEWER SERVICES	3,500	0	3,500	1,964.96	.00	1,535.04	56.1%
10042000 405140 STREET LIGHTS	11,500	0	11,500	12,502.36	.00	-1,002.36	108.7%*
10042000 405230 TELECOMMUNICATIONS	17,000	0	17,000	21,363.11	.00	-4,363.11	125.7%*
10042000 405304 PROPERTY INSURANCE	50,000	0	50,000	48,333.00	.00	1,667.00	96.7%
10042000 405308 GENERAL LIABILITY	10,000	0	10,000	9,673.00	.00	327.00	96.7%
10042000 405410 LEASE/RENT	0	0	0	2,033.09	.00	-2,033.09	100.0%*
TOTAL GENERAL SERVICES	569,200	-78,341	490,859	490,035.72	.00	823.28	99.8%

10/30/2018 14:34
5311epol

COUNTY OF FLUVANNA
FY18 Q4 YEAR-TO-DATE BUDGET REPORT

P 28
glytddb

FOR 2018 12

ACCOUNTS FOR: 100 GENERAL FUND	ORIGINAL APPROP	TRANFRS/ ADJSTMTS	REVISED BUDGET	YTD EXPENDED	ENCUMBRANCES	AVAILABLE BUDGET	PCT USED
425 PUBLIC WORKS							
<u>10042500 401100 FULL-TIME SALARIES</u>	174,199	143	174,342	174,341.66	.00	.34	100.0%
<u>10042500 401310 OVERTIME PAY</u>	0	0	0	59.64	.00	-59.64	100.0%*
<u>10042500 402100 FICA</u>	13,326	11	13,337	12,190.14	.00	1,146.86	91.4%
<u>10042500 402210 VRS</u>	14,929	12	14,941	15,078.12	.00	-137.12	100.9%*
<u>10042500 402250 DISABILITY</u>	213	0	213	552.36	.00	-339.36	259.3%*
<u>10042500 402300 MEDICAL INSURANCE</u>	32,340	1,199	33,539	33,414.12	.00	124.88	99.6%
<u>10042500 402400 GROUP LIFE</u>	2,282	2	2,284	2,304.72	.00	-20.72	100.9%*
<u>10042500 402700 WORKER'S COMPENSAT</u>	3,692	0	3,692	3,014.83	.00	677.17	81.7%
<u>10042500 403100 PROFESSIONAL SERVI</u>	10,000	-10,000	0	.00	.00	.00	.0%
<u>10042500 403182 SOFTWARE SUPPORT F</u>	5,500	-3,500	2,000	1,781.34	.00	218.66	89.1%
<u>10042500 403600 ADVERTISING</u>	0	0	0	91.60	.00	-91.60	100.0%*
<u>10042500 405230 TELECOMMUNICATIONS</u>	2,000	0	2,000	2,217.71	.00	-217.71	110.9%*
<u>10042500 405410 LEASE/RENT</u>	3,000	0	3,000	4,113.06	.00	-1,113.06	137.1%*
<u>10042500 405530 SUBSISTENCE & LODG</u>	1,000	-100	900	685.36	.00	214.64	76.2%
<u>10042500 405540 CONVENTION AND EDU</u>	2,500	-800	1,700	1,596.31	.00	103.69	93.9%
<u>10042500 406001 OFFICE SUPPLIES</u>	2,000	-700	1,300	1,253.62	.00	46.38	96.4%
<u>10042500 406004 GENERAL MATERIALS</u>	0	0	0	135.81	.00	-135.81	100.0%*
<u>10042500 406008 VEHICLE FUEL</u>	700	-400	300	228.62	.00	71.38	76.2%
<u>10042500 408105 VEHICLE</u>	0	0	0	20.00	.00	-20.00	100.0%*
TOTAL PUBLIC WORKS	267,681	-14,133	253,548	253,079.02	.00	468.98	99.8%



10/30/2018 14:34
5311epol

COUNTY OF FLUVANNA
FY18 Q4 YEAR-TO-DATE BUDGET REPORT

P 29
glytddbud

FOR 2018 12

ACCOUNTS FOR: 100 GENERAL FUND	ORIGINAL APPROP	TRANFRS/ ADJSTMTS	REVISED BUDGET	YTD EXPENDED	ENCUMBRANCES	AVAILABLE BUDGET	PCT USED
430 CONVENIENCE CENTER							
10043000 401100 FULL-TIME SALARIES	40,968	986	41,954	41,954.45	.00	-.45	100.0%*
10043000 401300 PART-TIME SALARIES	17,718	444	18,162	18,273.32	.00	-111.32	100.6%*
10043000 401310 OVERTIME PAY	1,500	0	1,500	5,665.71	.00	-4,165.71	377.7%*
10043000 401320 HOLIDAY & DISCRETI	0	0	0	1,089.79	.00	-1,089.79	100.0%*
10043000 402100 FICA	4,604	109	4,713	5,128.58	.00	-415.58	108.8%*
10043000 402210 VRS	3,511	84	3,595	3,546.00	.00	49.00	98.6%
10043000 402400 GROUP LIFE	537	13	550	542.04	.00	7.96	98.6%
10043000 402700 WORKER'S COMPENSAT	2,917	0	2,917	2,094.47	.00	822.53	71.8%
10043000 403100 PROFESSIONAL SERVI	30,000	0	30,000	25,924.00	.00	4,076.00	86.4%
10043000 403170 PERMITS AND FEES	1,200	0	1,200	1,097.00	.00	103.00	91.4%
10043000 403300 CONTRACT SERVICES	54,500	0	54,500	60,182.24	.00	-5,682.24	110.4%*
10043000 403310 BLDGS EQUIP REP &	20,500	-3,500	17,000	8,994.84	.00	8,005.16	52.9%
10043000 405230 TELECOMMUNICATIONS	1,250	0	1,250	1,895.01	.00	-645.01	151.6%*
10043000 405410 LEASE/RENT	800	0	800	780.00	.00	20.00	97.5%
10043000 406001 OFFICE SUPPLIES	550	0	550	129.12	.00	420.88	23.5%
10043000 406008 VEHICLE FUEL	500	0	500	1,331.55	.00	-831.55	266.3%*
10043000 406009 VEHICLE/POWER EQUI	750	0	750	.00	.00	750.00	.0%
TOTAL CONVENIENCE CENTER	181,805	-1,864	179,941	178,628.12	.00	1,312.88	99.3%



10/30/2018 14:34
5311epol

COUNTY OF FLUVANNA
FY18 Q4 YEAR-TO-DATE BUDGET REPORT

P 30
glytdbud

FOR 2018 12

ACCOUNTS FOR: 100 GENERAL FUND	ORIGINAL APPROP	TRANFRS/ ADJSTMTS	REVISED BUDGET	YTD EXPENDED	ENCUMBRANCES	AVAILABLE BUDGET	PCT USED
485 JAMES RIVER WATER AUTHORITY							
<u>10048500 407006 JRWA OPERATIONS</u>	0	19,062	19,062	17,705.39	.00	1,356.61	92.9%
<u>10048500 407007 JRWA DEBT PAYMENT</u>	0	234,663	234,663	232,708.72	.00	1,954.28	99.2%
TOTAL JAMES RIVER WATER AUTHORITY	0	253,725	253,725	250,414.11	.00	3,310.89	98.7%



10/30/2018 14:34
5311epol

COUNTY OF FLUVANNA
FY18 Q4 YEAR-TO-DATE BUDGET REPORT

P 31
glytddbud

FOR 2018 12

ACCOUNTS FOR: 100 GENERAL FUND	ORIGINAL APPROP	TRANFRS/ ADJSTMTS	REVISED BUDGET	YTD EXPENDED	ENCUMBRANCES	AVAILABLE BUDGET	PCT USED
510 HEALTH							
<u>10051000 403300 CONTRACT SERVICES</u>	269,790	0	269,790	269,790.00	.00	.00	100.0%
<u>10051000 405230 TELECOMMUNICATIONS</u>	0	0	0	-244.11	.00	244.11	100.0%
TOTAL HEALTH	269,790	0	269,790	269,545.89	.00	244.11	99.9%



10/30/2018 14:34
5311epol

COUNTY OF FLUVANNA
FY18 Q4 YEAR-TO-DATE BUDGET REPORT

P 32
glytdbud

FOR 2018 12

ACCOUNTS FOR: 100 GENERAL FUND	ORIGINAL APPROP	TRANFRS/ ADJSTMTS	REVISED BUDGET	YTD EXPENDED	ENCUMBRANCES	AVAILABLE BUDGET	PCT USED
515 VJCCA							
<u>10051500 403100 VJCCA PROFESSIONAL</u>	6,585	0	6,585	6,195.70	.00	389.30	94.1%
TOTAL VJCCA	6,585	0	6,585	6,195.70	.00	389.30	94.1%



10/30/2018 14:34
5311epol

COUNTY OF FLUVANNA
FY18 Q4 YEAR-TO-DATE BUDGET REPORT

P 33
glytddbud

FOR 2018 12

ACCOUNTS FOR: 100 GENERAL FUND	ORIGINAL APPROP	TRANFRS/ ADJSTMTS	REVISED BUDGET	YTD EXPENDED	ENCUMBRANCES	AVAILABLE BUDGET	PCT USED
520 CSA							
10052000 401100 FULL-TIME SALARIES	50,750	-6,100	44,650	44,649.73	.00	.27	100.0%
10052000 401310 OVERTIME PAY	0	2	2	2,180.93	.00	-2,178.93	*****%*
10052000 402100 FICA	3,882	-467	3,415	3,066.67	.00	348.33	89.8%
10052000 402210 VRS	4,349	-522	3,827	3,570.80	.00	256.20	93.3%
10052000 402300 MEDICAL INSURANCE	8,940	-840	8,100	8,100.00	.00	.00	100.0%
10052000 402400 GROUP LIFE	665	-80	585	545.80	.00	39.20	93.3%
10052000 402700 WORKER'S COMPENSAT	46	0	46	38.90	.00	7.10	84.6%
10052000 403100 PROFESSIONAL SERVI	1,500	0	1,500	263.00	.00	1,237.00	17.5%
10052000 403500 PRINTING AND BINDI	0	0	0	43.97	.00	-43.97	100.0%*
10052000 405210 POSTAL SERVICES	800	0	800	841.31	.00	-41.31	105.2%*
10052000 405230 TELECOMMUNICATIONS	150	0	150	28.16	.00	121.84	18.8%
10052000 405410 LEASE/RENT	750	0	750	582.54	.00	167.46	77.7%
10052000 405510 MILEAGE ALLOWANCES	600	0	600	241.34	.00	358.66	40.2%
10052000 405530 SUBSISTENCE & LODG	600	0	600	401.85	.00	198.15	67.0%
10052000 405540 CONVENTION AND EDU	300	0	300	208.00	.00	92.00	69.3%
10052000 406001 OFFICE SUPPLIES	1,000	101	1,101	1,762.33	.00	-661.33	160.1%*
10052000 406002 FOOD SUPPLIES	300	0	300	200.30	.00	99.70	66.8%
TOTAL CSA	74,632	-7,906	66,726	66,725.63	.00	.37	100.0%



10/30/2018 14:34
5311epol

COUNTY OF FLUVANNA
FY18 Q4 YEAR-TO-DATE BUDGET REPORT

P 34
glytddbud

FOR 2018 12

ACCOUNTS FOR: 100	GENERAL FUND	ORIGINAL APPROP	TRANFRS/ ADJSTMTS	REVISED BUDGET	YTD EXPENDED	ENCUMBRANCES	AVAILABLE BUDGET	PCT USED
525 CSA PURCHASE OF SERVICES								
10052500	405713	FF4E-COMM SVCS	0	0	460.00	.00	-460.00	100.0%*
10052500	405714	POS MANDATED FFMP	10,000	-10,000	.00	.00	.00	.0%
10052500	405715	POS MANDATED FFOP	25,000	143,500	168,500	167,721.66	778.34	99.5%
10052500	405716	TFC LIC. RES CONG	93,000	7,000	100,000	87,053.08	12,946.92	87.1%
10052500	405718	COMM SVCS	490,000	171,500	661,500	616,834.03	44,665.97	93.2%
10052500	405719	COMM SVCS. TRANSIT	15,000	35,000	50,000	66,364.30	-16,364.30	132.7%*
10052500	405720	NON-MAND COMM BASE	26,170	0	26,170	1,610.00	24,560.00	6.2%
10052500	405721	RES. CONG. CARE	719,287	0	719,287	343,958.80	375,328.20	47.8%
10052500	405723	POS MANDATED SPED-	1,050,000	0	1,050,000	900,002.50	149,997.50	85.7%
10052500	405724	POS MAND SVCS IN P	25,000	0	25,000	600.00	24,400.00	2.4%
10052500	405725	POS MAND FC LIC RE	50,000	0	50,000	147,500.00	-97,500.00	295.0%*
10052500	405726	POS MAND THER FC 4	0	3,000	3,000	51,880.00	-48,880.00	1729.3%*
10052500	405730	POS MAND PSYC HOSP	0	0	0	36,412.50	-36,412.50	100.0%*
10052500	405732	EDUC SVCS CONG CAR	200,000	0	200,000	422,979.47	-222,979.47	211.5%*
10052500	405742	POS MANDATED WSS	20,543	0	20,543	71,191.20	-50,648.20	346.5%*
10052500	406014	OTHER OPERATING SU	26,000	0	26,000	.00	26,000.00	.0%
TOTAL CSA PURCHASE OF SERVICES		2,750,000	350,000	3,100,000	2,914,567.54	.00	185,432.46	94.0%



10/30/2018 14:34
5311epol

COUNTY OF FLUVANNA
FY18 Q4 YEAR-TO-DATE BUDGET REPORT

P 35
glytddbud

FOR 2018 12

ACCOUNTS FOR: 100 GENERAL FUND	ORIGINAL APPROP	TRANFRS/ ADJSTMTS	REVISED BUDGET	YTD EXPENDED	ENCUMBRANCES	AVAILABLE BUDGET	PCT USED
710 PARKS & RECREATION							
10071000 401100 FULL-TIME SALARIES	189,664	-517	189,147	187,144.32	.00	2,002.68	98.9%
10071000 401300 PART-TIME SALARIES	56,310	17,410	73,720	67,661.45	.00	6,058.55	91.8%
10071000 401310 OVERTIME PAY	1,100	0	1,100	1,042.15	.00	57.85	94.7%
10071000 402100 FICA	18,878	1,293	20,171	19,219.81	.00	951.19	95.3%
10071000 402210 VRS	16,254	-71	16,183	15,738.40	.00	444.60	97.3%
10071000 402250 DISABILITY	347	0	347	279.17	.00	67.83	80.5%
10071000 402300 MEDICAL INSURANCE	31,020	-7,979	23,041	23,336.84	.00	-295.84	101.3%*
10071000 402400 GROUP LIFE	2,485	-11	2,474	2,408.77	.00	65.23	97.4%
10071000 402700 WORKER'S COMPENSAT	3,482	0	3,482	3,966.46	.00	-484.46	113.9%*
10071000 403100 PROFESSIONAL SERVI	38,200	2,500	40,700	19,440.91	.00	21,259.09	47.8%
10071000 403300 CONTRACT SERVICES	16,500	0	16,500	13,988.65	.00	2,511.35	84.8%
10071000 403300 CARN CONTRACT SERVI	10,300	0	10,300	9,760.99	.00	539.01	94.8%
10071000 403500 PRINTING AND BINDI	8,000	0	8,000	6,016.06	.00	1,983.94	75.2%
10071000 403600 ADVERTISING	2,000	0	2,000	236.00	.00	1,764.00	11.8%
10071000 403600 CARN ADVERTISING	1,500	0	1,500	858.00	.00	642.00	57.2%
10071000 405210 POSTAL SERVICES	600	0	600	391.36	.00	208.64	65.2%
10071000 405230 TELECOMMUNICATIONS	9,500	0	9,500	7,671.23	.00	1,828.77	80.7%
10071000 405410 LEASE/RENT	8,000	0	8,000	4,054.01	.00	3,945.99	50.7%
10071000 405510 MILEAGE ALLOWANCES	100	0	100	.00	.00	100.00	.0%
10071000 405530 SUBSISTENCE & LODG	1,700	0	1,700	867.89	.00	832.11	51.1%
10071000 405540 CONVENTION AND EDU	1,315	0	1,315	1,479.05	.00	-164.05	112.5%*
10071000 405810 DUES OR ASSOCIATIO	1,150	0	1,150	1,280.00	.00	-130.00	111.3%*
10071000 406001 OFFICE SUPPLIES	2,500	0	2,500	875.76	.00	1,624.24	35.0%
10071000 406004 GENERAL MATERIALS	0	0	0	581.03	.00	-581.03	100.0%*
10071000 406004 CARN GENERAL MATERI	2,500	0	2,500	2,448.01	.00	51.99	97.9%
10071000 406008 VEHICLE FUEL	3,000	0	3,000	3,235.96	.00	-235.96	107.9%*
10071000 406011 UNIFORM/WEARING AP	700	0	700	724.37	.00	-24.37	103.5%*
10071000 406012 BOOKS/PUBLICATIONS	250	0	250	.00	.00	250.00	.0%
10071000 406013 RECREATIONAL SUPPL	55,500	-243	55,257	49,117.98	.00	6,139.02	88.9%
10071000 406013 AMUSE RECREATIONAL	2,100	0	2,100	5,725.00	.00	-3,625.00	272.6%*
10071000 406013 FTBL RECREATIONAL S	1,500	0	1,500	.00	.00	1,500.00	.0%
10071000 408102 FURNITURE & FIXTUR	1,500	0	1,500	1,151.83	.00	348.17	76.8%
10071000 409904 SITE IMPROVEMENTS	18,000	0	18,000	5,363.96	.00	12,636.04	29.8%
TOTAL PARKS & RECREATION	505,955	12,382	518,337	456,065.42	.00	62,271.58	88.0%



10/30/2018 14:34
5311epol

COUNTY OF FLUVANNA
FY18 Q4 YEAR-TO-DATE BUDGET REPORT

P 36
glytddb

FOR 2018 12

ACCOUNTS FOR: 100 GENERAL FUND	ORIGINAL APPROP	TRANFRS/ ADJSTMTS	REVISED BUDGET	YTD EXPENDED	ENCUMBRANCES	AVAILABLE BUDGET	PCT USED
730 LIBRARY							
10073000 401100 FULL-TIME SALARIES	117,421	1,173	118,594	118,594.02	.00	-.02	100.0%*
10073000 401300 PART-TIME SALARIES	53,645	2,989	56,634	57,005.01	.00	-371.01	100.7%*
10073000 401310 OVERTIME PAY	0	0	0	4.00	.00	-4.00	100.0%*
10073000 402100 FICA	13,087	319	13,406	13,222.58	.00	183.42	98.6%
10073000 402210 VRS	10,063	101	10,164	10,163.76	.00	.24	100.0%
10073000 402250 DISABILITY	313	0	313	330.60	.00	-17.60	105.6%*
10073000 402300 MEDICAL INSURANCE	16,260	-234	16,026	16,026.00	.00	.00	100.0%
10073000 402400 GROUP LIFE	1,538	15	1,553	1,553.52	.00	-.52	100.0%*
10073000 402700 WORKER'S COMPENSAT	154	0	154	128.50	.00	25.50	83.4%
10073000 403320 MAINTENANCE CONTRA	16,360	0	16,360	7,826.49	.00	8,533.51	47.8%
10073000 405210 POSTAL SERVICES	400	0	400	196.00	.00	204.00	49.0%
10073000 405230 TELECOMMUNICATIONS	0	33,803	33,803	26,223.58	.00	7,579.04	77.6%
10073000 405230 LIBAD TELECOMMUNICA	24,936	-24,936	0	.00	.00	.00	.0%
10073000 405410 LEASE/RENT	120	0	120	79.92	.00	40.08	66.6%
10073000 405530 SUBSISTENCE & LODG	750	0	750	.00	.00	750.00	.0%
10073000 405540 CONVENTION AND EDU	750	0	750	30.00	.00	720.00	4.0%
10073000 405810 DUES OR ASSOCIATIO	200	0	200	265.00	.00	-65.00	132.5%*
10073000 406001 OFFICE SUPPLIES	8,000	0	8,000	10,029.15	.00	-2,029.15	125.4%*
10073000 406012 BOOKS/PUBLICATIONS	10,000	25	10,025	26,496.11	.00	-16,471.11	264.3%*
10073000 406012 LIBAD BOOKS/PUBLICA	71,600	2,838	74,438	74,666.95	.00	-228.95	100.3%*
10073000 408107 EDP EQUIPMENT	9,600	0	9,600	6,648.20	.00	2,951.80	69.3%
TOTAL LIBRARY	355,197	16,093	371,290	369,489.39	.00	1,800.23	99.5%



10/30/2018 14:34
5311epol

COUNTY OF FLUVANNA
FY18 Q4 YEAR-TO-DATE BUDGET REPORT

P 37
glytddbud

FOR 2018 12

ACCOUNTS FOR: 100 GENERAL FUND	ORIGINAL APPROP	TRANFRS/ ADJSTMTS	REVISED BUDGET	YTD EXPENDED	ENCUMBRANCES	AVAILABLE BUDGET	PCT USED
810 COUNTY PLANNER							
10081000 401100 FULL-TIME SALARIES	287,535	3,440	290,975	291,078.94	.00	-103.94	100.0%*
10081000 401300 PART-TIME SALARIES	0	5,080	5,080	5,797.50	.00	-717.50	114.1%*
10081000 401310 OVERTIME PAY	2,500	0	2,500	2,900.79	.00	-400.79	116.0%*
10081000 402100 FICA	22,188	652	22,840	21,454.70	.00	1,385.30	93.9%
10081000 402210 VRS	24,642	295	24,937	24,925.94	.00	11.06	100.0%
10081000 402250 DISABILITY	665	0	665	682.68	.00	-17.68	102.7%*
10081000 402300 MEDICAL INSURANCE	47,220	4,224	51,444	51,444.00	.00	.00	100.0%
10081000 402400 GROUP LIFE	3,767	45	3,812	3,809.99	.00	2.01	99.9%
10081000 402700 WORKER'S COMPENSAT	2,402	0	2,402	3,673.95	.00	-1,271.95	153.0%*
10081000 403100 PROFESSIONAL SERVI	0	0	0	1,061.14	.00	-1,061.14	100.0%*
10081000 403300 CONTRACT SERVICES	15,000	0	15,000	9,825.00	.00	5,175.00	65.5%
10081000 403600 ADVERTISING	0	0	0	385.65	.00	-385.65	100.0%*
10081000 405210 POSTAL SERVICES	500	0	500	286.22	.00	213.78	57.2%
10081000 405230 TELECOMMUNICATIONS	2,000	0	2,000	2,057.17	.00	-57.17	102.9%*
10081000 405410 LEASE/RENT	4,200	0	4,200	5,509.05	.00	-1,309.05	131.2%*
10081000 405510 MILEAGE ALLOWANCES	0	0	0	169.06	.00	-169.06	100.0%*
10081000 405530 SUBSISTENCE & LODG	1,500	0	1,500	.00	.00	1,500.00	.0%
10081000 405540 CONVENTION AND EDU	3,000	0	3,000	1,477.00	.00	1,523.00	49.2%
10081000 405810 DUES OR ASSOCIATIO	2,000	0	2,000	1,169.00	.00	831.00	58.5%
10081000 406001 OFFICE SUPPLIES	2,500	0	2,500	1,099.36	.00	1,400.64	44.0%
10081000 406008 VEHICLE FUEL	2,500	0	2,500	2,686.78	.00	-186.78	107.5%*
10081000 406011 UNIFORM/WEARING AP	600	0	600	.00	.00	600.00	.0%
10081000 406012 BOOKS/PUBLICATIONS	250	0	250	81.13	.00	168.87	32.5%
10081000 406014 OTHER OPERATING SU	0	0	0	177.10	.00	-177.10	100.0%*
10081000 408102 FURNITURE & FIXTUR	1,500	0	1,500	1,054.41	.00	445.59	70.3%
TOTAL COUNTY PLANNER	426,469	13,736	440,205	432,806.56	.00	7,398.44	98.3%



10/30/2018 14:34
5311epol

COUNTY OF FLUVANNA
FY18 Q4 YEAR-TO-DATE BUDGET REPORT

P 38
glytdbud

FOR 2018 12

ACCOUNTS FOR: 100 GENERAL FUND	ORIGINAL APPROP	TRANFRS/ ADJSTMTS	REVISED BUDGET	YTD EXPENDED	ENCUMBRANCES	AVAILABLE BUDGET	PCT USED
815 PLANNING COMMISSION							
<u>10081500 401114 BOARD COMPENSATION</u>	12,900	0	12,900	12,819.39	.00	80.61	99.4%
<u>10081500 402100 FICA</u>	987	0	987	956.42	.00	30.58	96.9%
<u>10081500 403100 PROFESSIONAL SERVI</u>	16,000	0	16,000	18,050.00	.00	-2,050.00	112.8%*
<u>10081500 403600 ADVERTISING</u>	6,500	0	6,500	1,611.25	.00	4,888.75	24.8%
<u>10081500 405210 POSTAL SERVICES</u>	3,000	0	3,000	2,198.22	.00	801.78	73.3%
<u>10081500 405510 MILEAGE ALLOWANCES</u>	200	0	200	110.21	.00	89.79	55.1%
<u>10081500 405530 SUBSISTENCE & LODG</u>	500	0	500	.00	.00	500.00	.0%
<u>10081500 405540 CONVENTION AND EDU</u>	750	0	750	.00	.00	750.00	.0%
<u>10081500 406001 OFFICE SUPPLIES</u>	0	0	0	551.63	.00	-551.63	100.0%*
<u>10081500 406014 OTHER OPERATING SU</u>	0	0	0	265.29	.00	-265.29	100.0%*
TOTAL PLANNING COMMISSION	40,837	0	40,837	36,562.41	.00	4,274.59	89.5%



10/30/2018 14:34
5311epol

COUNTY OF FLUVANNA
FY18 Q4 YEAR-TO-DATE BUDGET REPORT

P 39
glytdbud

FOR 2018 12

ACCOUNTS FOR: 100 GENERAL FUND	ORIGINAL APPROP	TRANFRS/ ADJSTMTS	REVISED BUDGET	YTD EXPENDED	ENCUMBRANCES	AVAILABLE BUDGET	PCT USED
820 BOARD OF ZONING APPEALS							
<u>10082000 401114 BOARD COMPENSATION</u>	1,200	0	1,200	840.00	.00	360.00	70.0%
<u>10082000 402100 FICA</u>	92	0	92	64.26	.00	27.74	69.8%
<u>10082000 403600 ADVERTISING</u>	1,000	0	1,000	315.00	.00	685.00	31.5%
<u>10082000 405510 MILEAGE ALLOWANCES</u>	100	0	100	.00	.00	100.00	.0%
<u>10082000 405540 CONVENTION AND EDU</u>	300	0	300	.00	.00	300.00	.0%
TOTAL BOARD OF ZONING APPEALS	2,692	0	2,692	1,219.26	.00	1,472.74	45.3%



10/30/2018 14:34
5311epol

COUNTY OF FLUVANNA
FY18 Q4 YEAR-TO-DATE BUDGET REPORT

P 40
glytddbud

FOR 2018 12

ACCOUNTS FOR: 100 GENERAL FUND	ORIGINAL APPROP	TRANFRS/ ADJSTMTS	REVISED BUDGET	YTD EXPENDED	ENCUMBRANCES	AVAILABLE BUDGET	PCT USED
830 ECONOMIC DEVELOPMENT							
10083000 401100 FULL-TIME SALARIES	77,324	3,464	80,788	80,787.69	.00	.31	100.0%
10083000 402100 FICA	5,915	265	6,180	5,741.73	.00	438.27	92.9%
10083000 402210 VRS	6,627	297	6,924	6,692.88	.00	231.12	96.7%
10083000 402300 MEDICAL INSURANCE	11,700	1,935	13,635	13,635.30	.00	-.30	100.0%*
10083000 402400 GROUP LIFE	1,013	45	1,058	1,023.12	.00	34.88	96.7%
10083000 402700 WORKER'S COMPENSAT	70	0	70	59.27	.00	10.73	84.7%
10083000 403600 ADVERTISING	750	0	750	914.10	.00	-164.10	121.9%*
10083000 403800 EDEV MARKETING	2,500	0	2,500	1,846.00	.00	654.00	73.8%
10083000 403800 TOUR MARKETING	7,500	0	7,500	7,936.00	.00	-436.00	105.8%*
10083000 405210 POSTAL SERVICES	100	0	100	37.35	.00	62.65	37.4%
10083000 405230 TELECOMMUNICATIONS	700	0	700	629.08	.00	70.92	89.9%
10083000 405510 MILEAGE ALLOWANCES	250	0	250	340.26	.00	-90.26	136.1%*
10083000 405530 SUBSISTENCE & LODG	1,600	0	1,600	727.23	.00	872.77	45.5%
10083000 405540 CONVENTION AND EDU	2,500	0	2,500	1,893.00	.00	607.00	75.7%
10083000 405810 DUES OR ASSOCIATIO	500	0	500	520.00	.00	-20.00	104.0%*
10083000 406001 OFFICE SUPPLIES	500	0	500	596.25	.00	-96.25	119.3%*
10083000 406014 OTHER OPERATING SU	2,600	0	2,600	4,255.65	.00	-1,655.65	163.7%*
10083000 407010 FLU ECO DEV AUTHOR	1,000	0	1,000	1,000.00	.00	.00	100.0%
TOTAL ECONOMIC DEVELOPMENT	123,149	6,006	129,155	128,634.91	.00	520.09	99.6%



10/30/2018 14:34
5311epol

COUNTY OF FLUVANNA
FY18 Q4 YEAR-TO-DATE BUDGET REPORT

P 41
glytdbud

FOR 2018 12

ACCOUNTS FOR: 100 GENERAL FUND	ORIGINAL APPROP	TRANFRS/ ADJSTMTS	REVISED BUDGET	YTD EXPENDED	ENCUMBRANCES	AVAILABLE BUDGET	PCT USED
840 COOPERATIVE EXTENSION							
<u>10084000 403300 CONTRACT SERVICES</u>	76,077	0	76,077	59,375.48	.00	16,701.52	78.0%
<u>10084000 405230 TELECOMMUNICATIONS</u>	650	0	650	237.92	.00	412.08	36.6%
<u>10084000 405410 LEASE/RENT</u>	250	0	250	146.00	.00	104.00	58.4%
<u>10084000 405540 CONVENTION AND EDU</u>	1,750	-1,000	750	278.58	.00	471.42	37.1%
<u>10084000 405810 DUES OR ASSOCIATIO</u>	400	0	400	200.00	.00	200.00	50.0%
<u>10084000 406001 OFFICE SUPPLIES</u>	500	1,000	1,500	1,310.02	.00	189.98	87.3%
<u>10084000 406003 AGRICULTURAL SUPPL</u>	1,200	0	1,200	585.19	.00	614.81	48.8%
<u>10084000 406014 OTHER OPERATING SU</u>	1,500	0	1,500	1,282.00	.00	218.00	85.5%
TOTAL COOPERATIVE EXTENSION	82,327	0	82,327	63,415.19	.00	18,911.81	77.0%



10/30/2018 14:34
5311epol

COUNTY OF FLUVANNA
FY18 Q4 YEAR-TO-DATE BUDGET REPORT

P 42
glytdbud

FOR 2018 12

ACCOUNTS FOR: 100 GENERAL FUND	ORIGINAL APPROP	TRANFRS/ ADJSTMTS	REVISED BUDGET	YTD EXPENDED	ENCUMBRANCES	AVAILABLE BUDGET	PCT USED
850 NON PROFITS							
10085000 405661 AGRICULTURAL REC C	0	30,000	30,000	30,000.00	.00	.00	100.0%
10085000 405670 PIEDMONT VA. COMM.	50,429	0	50,429	50,429.00	.00	.00	100.0%
10085000 405671 SMALL BUSINESS DEV	2,500	0	2,500	2,500.00	.00	.00	100.0%
10085000 405672 T J PLANNING DIST.	33,928	0	33,928	33,928.00	.00	.00	100.0%
10085000 405673 SOIL & WATER CONSE	20,000	0	20,000	20,000.00	.00	.00	100.0%
10085000 405674 JEFFERSON AREA BOA	83,946	0	83,946	83,946.00	.00	.00	100.0%
10085000 405675 MACAA	49,913	0	49,913	49,913.00	.00	.00	100.0%
10085000 405676 REGION TEN COMMUNI	126,250	0	126,250	126,250.00	.00	.00	100.0%
10085000 405677 JAUNT	79,404	0	79,404	79,404.00	.00	.00	100.0%
10085000 405678 T J EMS	16,095	0	16,095	16,095.00	.00	.00	100.0%
10085000 405679 CV PARTNERSHIP EC	13,081	0	13,081	13,081.00	.00	.00	100.0%
10085000 405680 PIEDMONT HOUSING A	2,100	0	2,100	2,100.00	.00	.00	100.0%
10085000 405681 READYKIDS (CYFS)	2,100	0	2,100	2,100.00	.00	.00	100.0%
10085000 405682 PIEDMONT WORKFORCE	3,896	0	3,896	3,896.00	.00	.00	100.0%
10085000 405683 JEFFERSON AREA CHI	51,000	0	51,000	51,000.00	.00	.00	100.0%
10085000 405684 SHELTER FOR HELP/E	9,000	0	9,000	9,000.00	.00	.00	100.0%
10085000 405685 OFFENDER AID & RES	13,261	0	13,261	13,261.00	.00	.00	100.0%
10085000 405686 LEGAL AID	4,000	0	4,000	4,000.00	.00	.00	100.0%
10085000 405687 SEXUAL ASSAULT RES	1,000	0	1,000	1,000.00	.00	.00	100.0%
10085000 405688 RIVANNA CONSERVATI	1,750	0	1,750	1,750.00	.00	.00	100.0%
10085000 405691 FLUVANNA HOUSING F	16,000	0	16,000	16,000.00	.00	.00	100.0%
10085000 405692 ARTS ARTS COUNCIL	10,000	0	10,000	10,000.00	.00	.00	100.0%
10085000 405693 COUNTY MUSEUM	525	0	525	525.00	.00	.00	100.0%
10085000 405694 LEADERSHIP DEVELOP	1,000	0	1,000	1,000.00	.00	.00	100.0%
10085000 407020 FLU CHAMBER OF COM	3,500	0	3,500	3,500.00	.00	.00	100.0%
TOTAL NON PROFITS	594,678	30,000	624,678	624,678.00	.00	.00	100.0%



10/30/2018 14:34
5311epol

COUNTY OF FLUVANNA
FY18 Q4 YEAR-TO-DATE BUDGET REPORT

P 43
glytdbud

FOR 2018 12

ACCOUNTS FOR: 100 GENERAL FUND	ORIGINAL APPROP	TRANFRS/ ADJSTMTS	REVISED BUDGET	YTD EXPENDED	ENCUMBRANCES	AVAILABLE BUDGET	PCT USED
860 MISCELLANEOUS NON DEPARTMENTAL							
10086000 401100 FULL-TIME SALARIES	87,607	-47,988	39,619	.00	.00	39,619.00	.0%
10086000 402300 MEDICAL INSURANCE	51,984	45,601	97,585	83,032.75	.00	14,552.25	85.1%
10086000 402903 EMPLOYEE ASSISTANC	3,000	-3,000	0	.00	.00	.00	.0%
10086000 403100 PROFESSIONAL SERVI	25,000	1,593	26,593	26,593.23	.00	.00	100.0%
10086000 405860 CONTINGENCY GRANTS	25,000	0	25,000	.00	.00	25,000.00	.0%
10086000 405870 BOARD CONTINGENCY	150,000	-150,000	0	.00	.00	.35	.0%
10086000 405880 PERSONNEL CONTINGE	75,000	-68,033	6,967	.00	.00	6,967.00	.0%
10086000 409904 SITE IMPROVEMENTS	-103,550	103,550	0	.00	.00	.00	.0%
TOTAL MISCELLANEOUS NON DEPARTMENTAL	314,041	-118,276	195,765	109,625.98	.00	86,138.60	56.0%
TOTAL GENERAL FUND	19,341,492	858,804	20,200,296	19,164,695.11	.00	1,035,600.54	94.9%
TOTAL EXPENSES	19,341,492	858,804	20,200,296	19,164,695.11	.00	1,035,600.54	



10/30/2018 14:34
5311epol

COUNTY OF FLUVANNA
FY18 Q4 YEAR-TO-DATE BUDGET REPORT

P 44
glytdbud

FOR 2018 12

ACCOUNTS FOR: 105 SOCIAL SERVICES	ORIGINAL APPROP	TRANFRS/ ADJSTMTS	REVISED BUDGET	YTD EXPENDED	ENCUMBRANCES	AVAILABLE BUDGET	PCT USED
530 SOCIAL SERVICE ADMINISTRATION							
10553000 401100 FULL-TIME SALARIES	1,180,431	0	1,180,431	1,209,473.23	.00	-29,042.23	102.5%*
10553000 401114 BOARD COMPENSATION	4,680	0	4,680	4,676.88	.00	3.12	99.9%
10553000 401300 PART-TIME SALARIES	26,249	0	26,249	18,499.58	.00	7,749.42	70.5%
10553000 401310 OVERTIME PAY	35,000	5,211	40,211	26,856.50	.00	13,354.50	66.8%
10553000 401320 HOLIDAY & DISCRETI	13,536	0	13,536	12,969.00	.00	567.00	95.8%
10553000 402100 FICA	96,382	0	96,382	92,146.85	.00	4,235.15	95.6%
10553000 402210 VRS	101,163	0	101,163	100,602.36	.00	560.64	99.4%
10553000 402250 DISABILITY	2,600	0	2,600	3,140.11	.00	-540.11	120.8%*
10553000 402300 MEDICAL INSURANCE	202,200	0	202,200	195,735.51	.00	6,464.49	96.8%
10553000 402400 GROUP LIFE	15,464	0	15,464	15,756.45	.00	-292.45	101.9%*
10553000 402700 WORKER'S COMPENSAT	3,764	0	3,764	2,924.76	.00	839.24	77.7%
10553000 402830 STAFF DEVELOPMENT	4,000	0	4,000	5,108.60	.00	-1,108.60	127.7%*
10553000 403100 PROFESSIONAL SERVI	46,700	0	46,700	72,294.68	.00	-25,594.68	154.8%*
10553000 403125 IT SERVICES	12,000	0	12,000	10,690.00	.00	1,310.00	89.1%
10553000 403310 BLDGS EQUIP REP &	4,760	0	4,760	10,353.00	.00	-5,593.00	217.5%*
10553000 403315 VEHICLES REP & MAI	7,000	0	7,000	2,895.78	.00	4,104.22	41.4%
10553000 403320 MAINTENANCE CONTRA	12,238	0	12,238	1,236.87	.00	11,001.13	10.1%
10553000 403600 ADVERTISING	1,400	0	1,400	357.00	.00	1,043.00	25.5%
10553000 405110 ELECTRICAL SERVICE	12,100	0	12,100	6,890.10	.00	5,209.90	56.9%
10553000 405210 POSTAL SERVICES	7,260	0	7,260	7,527.93	.00	-267.93	103.7%*
10553000 405230 TELECOMMUNICATIONS	24,290	0	24,290	23,574.46	.00	715.54	97.1%
10553000 405304 PROPERTY INSURANCE	6,000	0	6,000	5,761.70	.00	238.30	96.0%
10553000 405410 LEASE/RENT	14,009	0	14,009	14,009.28	.00	-.28	100.0%*
10553000 405510 MILEAGE ALLOWANCES	274	0	274	113.22	.00	160.78	41.3%
10553000 405530 SUBSISTENCE & LODG	4,000	0	4,000	4,719.30	.00	-719.30	118.0%*
10553000 405810 DUES OR ASSOCIATIO	1,485	0	1,485	1,436.67	.00	48.33	96.7%
10553000 406001 OFFICE SUPPLIES	24,000	0	24,000	26,434.83	.00	-2,434.83	110.1%*
10553000 406002 FOOD SUPPLIES	420	0	420	660.41	.00	-240.41	157.2%*
10553000 406005 JANITORIAL SUPPLIE	300	0	300	10.90	.00	289.10	3.6%
10553000 406008 VEHICLE FUEL	5,010	0	5,010	3,097.19	.00	1,912.81	61.8%
10553000 408101 MACHINERY AND EQUI	758	7,150	7,908	245.00	.00	7,663.00	3.1%
10553000 408102 FURNITURE & FIXTUR	0	0	0	11,419.49	.00	-11,419.49	100.0%*
10553000 409904 SITE IMPROVEMENTS	0	21,362	21,362	15,176.00	.00	6,186.00	71.0%
TOTAL SOCIAL SERVICE ADMINISTRATION	1,869,473	33,723	1,903,196	1,906,793.64	.00	-3,597.64	100.2%



10/30/2018 14:34
5311epol

COUNTY OF FLUVANNA
FY18 Q4 YEAR-TO-DATE BUDGET REPORT

P 45
glytdbud

FOR 2018 12

ACCOUNTS FOR: 105 SOCIAL SERVICES	ORIGINAL APPROP	TRANFRS/ ADJSTMTS	REVISED BUDGET	YTD EXPENDED	ENCUMBRANCES	AVAILABLE BUDGET	PCT USED
540 PUBLIC ASSISTANCE							
<u>10554000 405701 GENERAL RELIEF</u>	7,000	0	7,000	1,277.00	.00	5,723.00	18.2%
<u>10554000 405702 AUXILIARY GRANTS P</u>	27,079	0	27,079	21,936.00	.00	5,143.00	81.0%
<u>10554000 405705 AID TO DEPENDENT C</u>	2,000	0	2,000	.00	.00	2,000.00	.0%
<u>10554000 405706 ADC/FOSTER CARE</u>	28,721	0	28,721	84,284.77	.00	-55,563.77	293.5%*
<u>10554000 405707 EMERGENCY ASSISTAN</u>	500	0	500	.00	.00	500.00	.0%
<u>10554000 405708 FOSTERING FUTURES</u>	8,350	0	8,350	14,907.26	.00	-6,557.26	178.5%*
<u>10554000 405709 SPECIAL NEEDS ADOP</u>	152,000	0	152,000	69,086.00	.00	82,914.00	45.5%
<u>10554000 405712 SUBSIDIZED ADOPT T</u>	236,762	0	236,762	245,039.00	.00	-8,277.00	103.5%*
TOTAL PUBLIC ASSISTANCE	462,412	0	462,412	436,530.03	.00	25,881.97	94.4%



10/30/2018 14:34
5311epol

COUNTY OF FLUVANNA
FY18 Q4 YEAR-TO-DATE BUDGET REPORT

P 46
glytdbud

FOR 2018 12

ACCOUNTS FOR: 105 SOCIAL SERVICES	ORIGINAL APPROP	TRANFRS/ ADJSTMTS	REVISED BUDGET	YTD EXPENDED	ENCUMBRANCES	AVAILABLE BUDGET	PCT USED
550 PURCHASE OF SERVICES							
10555000 405711 PURCHASE OF SERVIC	60,313	0	60,313	40,082.13	.00	20,230.87	66.5%
TOTAL PURCHASE OF SERVICES	60,313	0	60,313	40,082.13	.00	20,230.87	66.5%



10/30/2018 14:34
5311epol

COUNTY OF FLUVANNA
FY18 Q4 YEAR-TO-DATE BUDGET REPORT

P 47
glytdbud

FOR 2018 12

ACCOUNTS FOR: 105 SOCIAL SERVICES	ORIGINAL APPROP	TRANFRS/ ADJSTMTS	REVISED BUDGET	YTD EXPENDED	ENCUMBRANCES	AVAILABLE BUDGET	PCT USED
560 DAYCARE PROGRAM							
<u>10556000 403100 PROFESSIONAL SERVI</u>	7,425	0	7,425	.00	.00	7,425.00	.0%
TOTAL DAYCARE PROGRAM	7,425	0	7,425	.00	.00	7,425.00	.0%



10/30/2018 14:34
5311epol

COUNTY OF FLUVANNA
FY18 Q4 YEAR-TO-DATE BUDGET REPORT

P 48
glytbdud

FOR 2018 12

ACCOUNTS FOR: 105 SOCIAL SERVICES	ORIGINAL APPROP	TRANFRS/ ADJSTMTS	REVISED BUDGET	YTD EXPENDED	ENCUMBRANCES	AVAILABLE BUDGET	PCT USED
570 FOSTER HOME COORDINATOR							
<u>10557000 403300 CONTRACT SERVICES</u>	1,400	0	1,400	.00	.00	1,400.00	.0%
<u>10557000 405711 PURCHASE OF SERVIC</u>	6,400	0	6,400	700.00	.00	5,700.00	10.9%
TOTAL FOSTER HOME COORDINATOR	7,800	0	7,800	700.00	.00	7,100.00	9.0%



10/30/2018 14:34
5311epol

COUNTY OF FLUVANNA
FY18 Q4 YEAR-TO-DATE BUDGET REPORT

P 49
glytdbud

FOR 2018 12

ACCOUNTS FOR: 105 SOCIAL SERVICES	ORIGINAL APPROP	TRANFRS/ ADJSTMTS	REVISED BUDGET	YTD EXPENDED	ENCUMBRANCES	AVAILABLE BUDGET	PCT USED
580 FAMILY SUPPORT							
<u>10558000 405711 PURCHASE OF SERVIC</u>	19,158	0	19,158	21,801.03	.00	-2,643.03	113.8%*
TOTAL FAMILY SUPPORT	19,158	0	19,158	21,801.03	.00	-2,643.03	113.8%
TOTAL SOCIAL SERVICES	2,426,581	33,723	2,460,304	2,405,906.83	.00	54,397.17	97.8%
TOTAL EXPENSES	2,426,581	33,723	2,460,304	2,405,906.83	.00	54,397.17	



10/30/2018 14:34
5311epol

COUNTY OF FLUVANNA
FY18 Q4 YEAR-TO-DATE BUDGET REPORT

P 50
glytdbud

FOR 2018 12

	ORIGINAL APPROP	TRANFRS/ ADJSTMTS	REVISED BUDGET	YTD EXPENDED	ENCUMBRANCES	AVAILABLE BUDGET	PCT USED
GRAND TOTAL	21,768,073	892,527	22,660,600	21,570,601.94	.00	1,089,997.71	95.2%

** END OF REPORT - Generated by Eric Pollitt **

11/05/2018 11:16
5311epol

COUNTY OF FLUVANNA
FY18 Q4 YEAR-TO-DATE BUDGET REPORT

P 1
glytdbud

FOR 2018 12

ACCOUNTS FOR: 251 SCHOOL	ORIGINAL APPROP	TRANFRS/ ADJSTMTS	REVISED BUDGET	YTD EXPENDED	ENCUMBRANCES	AVAILABLE BUDGET	PCT USED
610 VSUP							
25161000 496000 VSUP INSTRUCTION	0	0	0	-21.94	.00	21.94	100.0%
620 INSTRUCTION							
25162000 496001 INSTRUCTION	30,003,269	455,000	30,458,269	29,295,451.92	.00	1,162,817.18	96.2%
630 ADMIN/ATTENDANCE/HEALTH							
25163000 496002 ADMIN,ATTENDANCE &	1,724,826	0	1,724,826	1,518,440.55	.00	206,385.45	88.0%
640 PUPIL TRANSPORTATION SERV							
25164000 496003 PUPIL TRANSPORTATI	2,776,239	0	2,776,239	2,755,584.42	.00	20,654.58	99.3%
650 OPERATION & MAINT SERV							
25165000 496004 OPERATION AND MAIN	3,379,419	80,000	3,459,419	3,544,128.33	.00	-84,709.33	102.4%*
670 TECHNOLOGY							
25167000 496008 TECHNOLOGY	1,751,034	180,000	1,931,034	1,710,316.53	.00	220,717.47	88.6%
TOTAL SCHOOL	39,634,787	715,000	40,349,787	38,823,899.81	.00	1,525,887.29	96.2%
TOTAL EXPENSES	39,634,787	715,000	40,349,787	38,823,899.81	.00	1,525,887.29	



11/05/2018 11:16
5311epol

COUNTY OF FLUVANNA
FY18 Q4 YEAR-TO-DATE BUDGET REPORT

P 2
glytdbud

FOR 2018 12

ACCOUNTS FOR: 252 CAFETERIA	ORIGINAL APPROP	TRANFRS/ ADJSTMTS	REVISED BUDGET	YTD EXPENDED	ENCUMBRANCES	AVAILABLE BUDGET	PCT USED
680 CAFETERIA							
<u>25268000 406002 FOOD SUPPLIES</u>	1,597,046	0	1,597,046	1,359,728.04	.00	237,317.96	85.1%
TOTAL CAFETERIA	1,597,046	0	1,597,046	1,359,728.04	.00	237,317.96	85.1%
TOTAL EXPENSES	1,597,046	0	1,597,046	1,359,728.04	.00	237,317.96	



11/05/2018 11:20
5311epol

COUNTY OF FLUVANNA
FY18 Q4 YEAR-TO-DATE BUDGET REPORT

P 4
glytddb

FOR 2018 12

ACCOUNTS FOR: 401	FOR: DEBT SERVICE	ORIGINAL APPROP	TRANFRS/ ADJSTMTS	REVISED BUDGET	YTD EXPENDED	ENCUMBRANCES	AVAILABLE BUDGET	PCT USED
910 DEBT SERVICE - COUNTY								
40109910	495000	ADMINISTRATIVE FEE	18,132	9,272	27,404	20,504.28	.00	6,899.72 74.8%
40109910	495050	2014 FIRE TRUCK -	40,000	0	40,000	40,000.00	.00	.00 100.0%
40109910	495051	2014 FIRE TRUCK -	18,869	0	18,869	18,869.00	.00	.00 100.0%
40109910	495052	2014C - COURTHOUSE	120,000	0	120,000	120,000.00	.00	.00 100.0%
40109910	495053	2014C - COURTHOUSE	64,906	0	64,906	64,906.00	.00	.00 100.0%
40109910	495054	2014C - LIBRARY PR	195,000	0	195,000	195,000.00	.00	.00 100.0%
40109910	495055	2014C - LIBRARY IN	49,472	0	49,472	49,471.90	.00	.10 100.0%
40109910	495056	2016 PUBLIC SAFETY	1,096,159	0	1,096,159	1,096,159.00	.00	.00 100.0%
40109910	495057	2016 PUBLIC SAFETY	140,130	0	140,130	139,903.25	.00	226.75 99.8%
40109910	495058	2017 ENERGY PERFOR	236,000	0	236,000	236,000.00	.00	.00 100.0%
40109910	495059	2017 ENERGY PERFOR	29,544	240,570	270,114	270,114.33	.00	-.08 100.0%*
40109910	495999	DEBT PLACEHOLDER	253,725	-253,725	0	.00	.00	.00 .0%
40109910	496006	REDEMPTION OF PRIN	1,595,735	-1,595,735	0	.00	.00	.00 .0%
TOTAL DEBT SERVICE - COUNTY			3,857,672	-1,599,618	2,258,054	2,250,927.76	.00	7,126.49 99.7%
920 DEBT SERVICE - SCHOOLS								
40109920	495004	VPSA 1999 SERIES C	50,000	0	50,000	50,000.00	.00	.00 100.0%
40109920	495006	G O SCH BONDS 2005	323,911	0	323,911	323,911.00	.00	.00 100.0%
40109920	495014	VPSA 1999 SERIES-C	6,500	0	6,500	6,500.00	.00	.00 100.0%
40109920	495016	G O SCH BOND 2005A	146,714	0	146,714	146,713.85	.00	.15 100.0%
40109920	495020	HS VPSA S O 2008 I	131,469	0	131,469	131,468.75	.00	.25 100.0%
40109920	495036	VPSA OSCB SERIES 2	426,825	0	426,825	426,825.00	.00	.00 100.0%
40109920	495037	NEW HS VPSA SPEC 0	1,770,000	0	1,770,000	1,770,000.00	.00	.00 100.0%
40109920	495044	VPSA SERIES 2012B	675,000	0	675,000	675,000.00	.00	.00 100.0%
40109920	495045	VPSA SERIES 2012B	2,316,625	0	2,316,625	2,316,625.00	.00	.00 100.0%
40109920	495046	VPSA SERIES 2012A	240,000	0	240,000	240,000.00	.00	.00 100.0%
40109920	495047	VPSA SERIES 2012A	112,750	0	112,750	112,750.00	.00	.00 100.0%
40109920	495048	VPSA SERIES 2014C	225,000	0	225,000	225,000.00	.00	.00 100.0%
40109920	495049	VPSA SERIES 2014C	186,161	0	186,161	186,161.25	.00	-.25 100.0%*
TOTAL DEBT SERVICE - SCHOOLS			6,610,955	0	6,610,955	6,610,954.85	.00	.15 100.0%
TOTAL DEBT SERVICE			10,468,627	-1,599,618	8,869,009	8,861,882.61	.00	7,126.64 99.9%
TOTAL EXPENSES			10,468,627	-1,599,618	8,869,009	8,861,882.61	.00	7,126.64

11/05/2018 11:16
5311epol

COUNTY OF FLUVANNA
FY18 Q4 YEAR-TO-DATE BUDGET REPORT

P 4
glytdbud

FOR 2018 12

ACCOUNTS FOR: 502 SEWER	ORIGINAL APPROP	TRANFRS/ ADJSTMTS	REVISED BUDGET	YTD EXPENDED	ENCUMBRANCES	AVAILABLE BUDGET	PCT USED
000 NON DEPT							
50200000 401100 FULL-TIME SALARIES	92,950	313	93,263	77,910.70	.00	15,352.30	83.5%
50200000 401310 OVERTIME PAY	2,000	0	2,000	1,656.97	.00	343.03	82.8%
50200000 401320 HOLIDAY & DISCRETI	1,000	0	1,000	3,079.85	.00	-2,079.85	308.0%*
50200000 402100 FICA	5,810	24	5,834	5,496.80	.00	337.20	94.2%
50200000 402210 VRS	6,252	0	6,252	6,314.28	.00	-62.28	101.0%*
50200000 402300 MEDICAL INSURANCE	23,400	-402	22,998	23,180.25	.00	-182.25	100.8%*
50200000 402400 GROUP LIFE	956	0	956	965.16	.00	-9.16	101.0%*
50200000 402700 WORKER'S COMPENSAT	1,495	0	1,495	1,267.41	.00	227.59	84.8%
50200000 403170 PERMITS AND FEES	12,500	0	12,500	4,354.00	.00	8,146.00	34.8%
50200000 403300 CONTRACT SERVICES	30,000	0	30,000	21,339.14	.00	8,660.86	71.1%
50200000 403310 BLDGS EQUIP REP &	10,000	0	10,000	13,897.02	.00	-3,897.02	139.0%*
50200000 403315 VEHICLES REP & MAI	5,000	0	5,000	.00	.00	5,000.00	.0%
50200000 403600 ADVERTISING	600	0	600	470.58	.00	129.42	78.4%
50200000 403700 LAUNDRY AND DRY CL	800	0	800	458.54	.00	341.46	57.3%
50200000 405110 ELECTRICAL SERVICE	14,000	0	14,000	11,291.80	.00	2,708.20	80.7%
50200000 405210 POSTAL SERVICES	400	0	400	144.78	.00	255.22	36.2%
50200000 405230 TELECOMMUNICATIONS	2,000	0	2,000	3,170.24	.00	-1,170.24	158.5%*
50200000 405540 CONVENTION AND EDU	1,500	0	1,500	504.50	.00	995.50	33.6%
50200000 405810 DUES OR ASSOCIATIO	300	0	300	.00	.00	300.00	.0%
50200000 405998 BAD DEBT EXPENSE	0	0	0	2,254.66	.00	-2,254.66	100.0%*
50200000 406001 OFFICE SUPPLIES	700	0	700	36.67	.00	663.33	5.2%
50200000 406003 AGRICULTURAL SUPPL	3,000	0	3,000	.00	.00	3,000.00	.0%
50200000 406004 GENERAL MATERIALS	10,500	0	10,500	8,934.41	.00	1,565.59	85.1%
50200000 406006 CHEMICAL SUPPLIES	15,000	0	15,000	21,858.39	.00	-6,858.39	145.7%*
50200000 406008 VEHICLE FUEL	4,400	0	4,400	88.06	.00	4,311.94	2.0%
50200000 406009 VEHICLE/POWER EQUI	0	0	0	104.46	.00	-104.46	100.0%*
50200000 408110 DEPRECIATION EXPEN	50,000	0	50,000	96,615.00	.00	-46,615.00	193.2%*
50200000 409111 REDEMPTION OF PRIN	60,000	0	60,000	.00	.00	60,000.00	.0%
TOTAL SEWER	354,563	-65	354,498	305,393.67	.00	49,104.33	86.1%
TOTAL EXPENSES	354,563	-65	354,498	305,393.67	.00	49,104.33	

11/05/2018 11:16
5311epol

COUNTY OF FLUVANNA
FY18 Q4 YEAR-TO-DATE BUDGET REPORT

P 5
glytddb

FOR 2018 12

ACCOUNTS FOR:	ORIGINAL APPROP	TRANFRS/ ADJSTMTS	REVISED BUDGET	YTD EXPENDED	ENCUMBRANCES	AVAILABLE BUDGET	PCT USED
505 FORK UNION SANITARY DISTRICT							
000 NON DEPT							
50500000 401100 FULL-TIME SALARIES	90,200	625	90,825	93,935.69	.00	-3,110.69	103.4%*
50500000 401310 OVERTIME PAY	5,000	0	5,000	2,940.57	.00	2,059.43	58.8%
50500000 401320 HOLIDAY & DISCRETI	2,000	0	2,000	3,707.29	.00	-1,707.29	185.4%*
50500000 402100 FICA	7,436	48	7,484	6,977.41	.00	506.59	93.2%
50500000 402210 VRS	7,730	0	7,730	7,807.32	.00	-77.32	101.0%*
50500000 402300 MEDICAL INSURANCE	20,640	3,119	23,759	23,700.00	.00	59.00	99.8%
50500000 402400 GROUP LIFE	1,182	0	1,182	1,193.40	.00	-11.40	101.0%*
50500000 402700 WORKER'S COMPENSAT	3,094	0	3,094	2,404.44	.00	689.56	77.7%
50500000 403100 PROFESSIONAL SERVI	3,500	0	3,500	1,744.32	.00	1,755.68	49.8%
50500000 403170 PERMITS AND FEES	7,250	0	7,250	3,242.10	.00	4,007.90	44.7%
50500000 403310 BLDGS EQUIP REP &	27,200	0	27,200	11,271.30	.00	15,928.70	41.4%
50500000 403315 VEHICLES REP & MAI	0	0	0	297.35	.00	-297.35	100.0%*
50500000 403600 ADVERTISING	400	0	400	.00	.00	400.00	.0%
50500000 403700 LAUNDRY AND DRY CL	2,500	0	2,500	1,738.59	.00	761.41	69.5%
50500000 405110 ELECTRICAL SERVICE	38,000	0	38,000	28,202.71	.00	9,797.29	74.2%
50500000 405210 POSTAL SERVICES	2,800	0	2,800	2,820.99	.00	-20.99	100.7%*
50500000 405230 TELECOMMUNICATIONS	5,700	0	5,700	6,063.88	.00	-363.88	106.4%*
50500000 405304 PROPERTY INSURANCE	200	0	200	200.00	.00	.00	100.0%
50500000 405305 VEHICLE INSURANCE	2,300	0	2,300	1,953.20	.00	346.80	84.9%
50500000 405410 LEASE/RENT	1,800	0	1,800	1,800.00	.00	.00	100.0%
50500000 405540 CONVENTION AND EDU	1,500	0	1,500	98.00	.00	1,402.00	6.5%
50500000 405711 PURCHASE OF SERVIC	4,000	0	4,000	1,395.00	.00	2,605.00	34.9%
50500000 405810 DUES OR ASSOCIATIO	700	0	700	.00	.00	700.00	.0%
50500000 406001 OFFICE SUPPLIES	1,000	0	1,000	721.64	.00	278.36	72.2%
50500000 406004 GENERAL MATERIALS	7,000	0	7,000	12,295.90	.00	-5,295.90	175.7%*
50500000 406006 CHEMICAL SUPPLIES	16,000	0	16,000	14,438.76	.00	1,561.24	90.2%
50500000 406008 VEHICLE FUEL	7,000	0	7,000	6,118.93	.00	881.07	87.4%
50500000 406009 VEHICLE/POWER EQUI	1,200	0	1,200	1,228.45	.00	-28.45	102.4%*
50500000 408101 MACHINERY AND EQUI	2,500	0	2,500	.00	.00	2,500.00	.0%
50500000 408110 DEPRECIATION EXPEN	0	0	0	87,790.00	.00	-87,790.00	100.0%*
50500000 409111 REDEMPTION OF PRIN	50,778	0	50,778	.00	.00	50,778.00	.0%
50500000 409115 REDEMPTION OF INTE	34,109	0	34,109	19,683.00	.00	14,426.00	57.7%
TOTAL FORK UNION SANITARY DISTRICT	354,719	3,792	358,511	345,770.24	.00	12,740.76	96.4%
TOTAL EXPENSES	354,719	3,792	358,511	345,770.24	.00	12,740.76	



11/05/2018 10:18
5311epol

COUNTY OF FLUVANNA
FY18 Q4 YEAR-TO-DATE BUDGET REPORT

P 3
glytdbud

FOR 2018 12

ACCOUNTS FOR: 510	ZION XR WATER & SEWER	ORIGINAL APPROP	TRANFRS/ ADJSTMTS	REVISED BUDGET	YTD EXPENDED	ENCUMBRANCES	AVAILABLE BUDGET	PCT USED
<u>51000000 409115</u>	<u>REDEMPTION OF INTE</u>	0	224,852	224,852	249,218.50	.00	-24,366.50	110.8%*
	TOTAL NO PROJECT	0	224,852	224,852	249,218.50	.00	-24,366.50	110.8%
<u>18ZXR ZXR WATER & SEWER SYSTEM PROJECT</u>								
<u>51000000 403100</u>	<u>18ZXR PROFESSIONAL</u>	0	338,733	338,733	155,392.50	.00	183,340.69	45.9%
<u>51000000 403102</u>	<u>18ZXR COUNTY ATTY L</u>	0	0	0	34,897.06	.00	-34,897.06	100.0%*
<u>51000000 403170</u>	<u>18ZXR PERMITS AND F</u>	0	4,000	4,000	.00	.00	4,000.00	.0%
<u>51000000 403180</u>	<u>18ZXR CONTINGENCY</u>	0	1,523,836	1,523,836	.00	.00	1,523,836.10	.0%
<u>51000000 403191</u>	<u>18ZXR CONSULTING SE</u>	0	500,000	500,000	.00	.00	500,000.00	.0%
<u>51000000 403420</u>	<u>18ZXR CONSTRUCTION</u>	0	6,132,000	6,132,000	.00	.00	6,132,000.00	.0%
<u>51000000 403430</u>	<u>18ZXR BOND ISSUANCE</u>	0	142,526	142,526	140,760.67	.00	1,765.53	98.8%
<u>51000000 403600</u>	<u>18ZXR ADVERTISING</u>	0	217	217	217.00	.00	.00	100.0%
<u>51000000 408108</u>	<u>18ZXR LAND</u>	0	150,000	150,000	.00	.00	150,000.00	.0%
	TOTAL ZXR WATER & SEWER SYSTEM PROJE	0	8,791,312	8,791,312	331,267.23	.00	8,460,045.26	3.8%
	TOTAL ZION XR WATER & SEWER	0	9,016,164	9,016,164	580,485.73	.00	8,435,678.76	6.4%
	TOTAL EXPENSES	0	9,016,164	9,016,164	580,485.73	.00	8,435,678.76	



11/05/2018 11:34
5311epol

COUNTY OF FLUVANNA
FY18 Q4 YEAR-TO-DATE BUDGET REPORT

P 1
glytddbud

FOR 2018 12

ACCOUNTS FOR: 302	FOR: CAPITAL IMPROVEMENT	ORIGINAL APPROP	TRANFRS/ ADJSTMTS	REVISED BUDGET	YTD EXPENDED	ENCUMBRANCES	AVAILABLE BUDGET	PCT USED
30286000	403445							
	EARLY REDEMPTION C	459	-459	0	.00	.00	.00	.0%
30286000	403446	1,595,735	0	1,595,735	1,595,733.26	.00	1.74	100.0%
	EARLY REDEMPTION L							
	TOTAL NO PROJECT	1,596,194	-459	1,595,735	1,595,733.26	.00	1.74	100.0%
<hr/>								
13PLA ELEMENTARY SCHOOLS PLAYGROUND EQUIP								
30265000	403300							
	13PLA CONTRACT SERV	27,535	0	27,535	27,375.00	.00	160.00	99.4%
	TOTAL ELEMENTARY SCHOOLS PLAYGROUND	27,535	0	27,535	27,375.00	.00	160.00	99.4%
<hr/>								
13WWM MIDDLE SCHOOL WASTEWATER								
30265000	403300							
	13WWM CONTRACT SERV	27,450	0	27,450	.00	.00	27,450.34	.0%
	TOTAL MIDDLE SCHOOL WASTEWATER	27,450	0	27,450	.00	.00	27,450.34	.0%
<hr/>								
14BLD COUNTYWIDE BUILDING ASSESSMENTS								
30241500	403100							
	14BLD PROFESSIONAL	21,860	0	21,860	.00	.00	21,860.00	.0%
	TOTAL COUNTYWIDE BUILDING ASSESSMENT	21,860	0	21,860	.00	.00	21,860.00	.0%
<hr/>								
14CUE CARYSBROOK UPPER ELEMENTARY RENOV.								
30265000	403300							
	14CUE CONTRACT SERV	138,978	150,000	288,978	31,068.00	.00	257,909.87	10.8%
	TOTAL CARYSBROOK UPPER ELEMENTARY RE	138,978	150,000	288,978	31,068.00	.00	257,909.87	10.8%
<hr/>								
14FIN SCHOOLS MUNIS SOFTWARE								
30267000	403300							
	14FIN CONTRACT SERV	1,858	0	1,858	1,857.56	.00	.00	100.0%
	TOTAL SCHOOLS MUNIS SOFTWARE	1,858	0	1,858	1,857.56	.00	.00	100.0%



11/05/2018 11:34
5311epol

COUNTY OF FLUVANNA
FY18 Q4 YEAR-TO-DATE BUDGET REPORT

P 2
glytdbud

FOR 2018 12

ACCOUNTS FOR: 302 CAPITAL IMPROVEMENT	ORIGINAL APPROP	TRANFRS/ ADJSTMTS	REVISED BUDGET	YTD EXPENDED	ENCUMBRANCES	AVAILABLE BUDGET	PCT USED
<u>14PPE F&R PERSONAL PROTECTIVE EQUIPMENT</u>							
30232500 403300 14PPE CONTRACT SERV	20,021	0	20,021	15,559.92	.00	4,460.68	77.7%
TOTAL F&R PERSONAL PROTECTIVE EQUIPM	20,021	0	20,021	15,559.92	.00	4,460.68	77.7%
<u>14WTR FUSD SYSTEM WATER SOURCE</u>							
30286000 403300 14WTR CONTRACT SERV	525,000	0	525,000	.00	.00	525,000.00	.0%
TOTAL FUSD SYSTEM WATER SOURCE	525,000	0	525,000	.00	.00	525,000.00	.0%
<u>14WWT RECOAT WASTEWATER TREATMENT PLANT</u>							
30265000 403300 14WWT CONTRACT SERV	70,000	0	70,000	.00	.00	70,000.00	.0%
TOTAL RECOAT WASTEWATER TREATMENT PL	70,000	0	70,000	.00	.00	70,000.00	.0%
<u>15CCT CONVENIENCE CENTER ROAD & TRAILER</u>							
30242500 408105 15CCT VEHICLE	21,475	-21,475	0	.00	.00	.00	.0%
30242500 408109 15CCT BUILDING	21,475	0	21,475	16,150.00	.00	5,325.00	75.2%
TOTAL CONVENIENCE CENTER ROAD & TRAI	42,950	-21,475	21,475	16,150.00	.00	5,325.00	75.2%
<u>15LPW LIBRARY-PS POTABLE WATER</u>							
30241500 403300 15LPW CONTRACT SERV	50,000	0	50,000	.00	.00	50,000.00	.0%
TOTAL LIBRARY-PS POTABLE WATER	50,000	0	50,000	.00	.00	50,000.00	.0%
<u>15MSR MIDDLE SCHOOL HVAC GYM LOCKER ROOM</u>							
30265000 403100 15MSR PROFESSIONAL	3,674	0	3,674	3,117.65	.00	556.24	84.9%



11/05/2018 11:34
5311epol

COUNTY OF FLUVANNA
FY18 Q4 YEAR-TO-DATE BUDGET REPORT

P 3
glytdbud

FOR 2018 12

ACCOUNTS FOR: 302 CAPITAL IMPROVEMENT	ORIGINAL APPROP	TRANFRS/ ADJSTMTS	REVISED BUDGET	YTD EXPENDED	ENCUMBRANCES	AVAILABLE BUDGET	PCT USED
<u>30265000 403300 15MSR CONTRACT SERV</u>	364,411	0	364,411	261,812.32	.00	102,598.69	71.8%
TOTAL MIDDLE SCHOOL HVAC GYM LOCKER	368,085	0	368,085	264,929.97	.00	103,154.93	72.0%
<u>15SSU SCHOOLS SAFETY AND SECURITY UPGRADE</u>							
<u>30265000 403300 15SSU CONTRACT SERV</u>	33,774	0	33,774	27,888.00	.00	5,886.07	82.6%
TOTAL SCHOOLS SAFETY AND SECURITY UP	33,774	0	33,774	27,888.00	.00	5,886.07	82.6%
<u>16CAM EVIDENTIARY CAMERAS</u>							
<u>30231000 403300 16CAM CONTRACT SERV</u>	395	0	395	825.00	.00	-430.10	208.9%*
TOTAL EVIDENTIARY CAMERAS	395	0	395	825.00	.00	-430.10	208.9%
<u>16FHM FARM HERITAGE MUSEUM</u>							
<u>30271000 403100 16FHM PROFESSIONAL</u>	-1,905	4,574	2,669	8,584.00	.00	-5,915.20	321.6%*
<u>30271000 403300 16FHM CONTRACT SERV</u>	160,825	167,570	328,395	315,458.80	.00	12,936.20	96.1%
TOTAL FARM HERITAGE MUSEUM	158,920	172,144	331,064	324,042.80	.00	7,021.00	97.9%
<u>16FON VoIP PHONE SYSTEM</u>							
<u>30215000 403300 16FON CONTRACT SERV</u>	144,925	0	144,925	.00	.00	144,925.00	.0%
TOTAL VoIP PHONE SYSTEM	144,925	0	144,925	.00	.00	144,925.00	.0%
<u>16SFL FLOOR COVERING REPLACEMENT</u>							
<u>30265000 403300 16SFL CONTRACT SERV</u>	156,784	0	156,784	129,406.13	.00	27,377.91	82.5%
TOTAL FLOOR COVERING REPLACEMENT	156,784	0	156,784	129,406.13	.00	27,377.91	82.5%
<u>17ACM ACCESS CONTROL MONITORING SYSTEM</u>							



11/05/2018 11:34
5311epol

COUNTY OF FLUVANNA
FY18 Q4 YEAR-TO-DATE BUDGET REPORT

P 4
glytdbud

FOR 2018 12

ACCOUNTS FOR: 302 CAPITAL IMPROVEMENT	ORIGINAL APPROP	TRANFRS/ ADJSTMTS	REVISED BUDGET	YTD EXPENDED	ENCUMBRANCES	AVAILABLE BUDGET	PCT USED
<u>30231000 403300 17ACM CONTRACT SERV</u>	82,814	0	82,814	73,295.00	.00	9,518.50	88.5%
TOTAL ACCESS CONTROL MONITORING SYST	82,814	0	82,814	73,295.00	.00	9,518.50	88.5%
<u>17CAD E911 COMPUTER AIDED DISPATCH SYSTEM</u>							
<u>30232000 403300 17CAD CONTRACT SERV</u>	498,543	0	498,543	230,750.22	.00	267,792.68	46.3%
TOTAL E911 COMPUTER AIDED DISPATCH S	498,543	0	498,543	230,750.22	.00	267,792.68	46.3%
<u>17CFA COURTS FIRE DETECTION SYSTEM</u>							
<u>30241500 403300 17CFA CONTRACT SERV</u>	35,000	-25,683	9,317	9,316.69	.00	.00	100.0%
TOTAL COURTS FIRE DETECTION SYSTEM	35,000	-25,683	9,317	9,316.69	.00	.00	100.0%
<u>17CLC COURTS LIGHTING CONTROL REPLACEMENT</u>							
<u>30241500 403300 17CLC CONTRACT SERV</u>	30,000	-17,152	12,848	12,847.68	.00	.00	100.0%
TOTAL COURTS LIGHTING CONTROL REPLAC	30,000	-17,152	12,848	12,847.68	.00	.00	100.0%
<u>17FBR COUNTY FIBER INFRASTRUCTURE</u>							
<u>30215000 403300 17FBR CONTRACT SERV</u>	31,592	8,455	40,047	.00	.00	40,047.00	.0%
TOTAL COUNTY FIBER INFRASTRUCTURE	31,592	8,455	40,047	.00	.00	40,047.00	.0%
<u>17FSU FACILITIES SECURTIY UPGRADES</u>							
<u>30241500 403300 17FSU CONTRACT SERV</u>	4,840	0	4,840	.00	.00	4,839.50	.0%
TOTAL FACILITIES SECURTIY UPGRADES	4,840	0	4,840	.00	.00	4,839.50	.0%
<u>17MNS NEW MUNIS MODULES IMPLEMENTATION</u>							



11/05/2018 11:34
5311epol

COUNTY OF FLUVANNA
FY18 Q4 YEAR-TO-DATE BUDGET REPORT

P 5
glytdbud

FOR 2018 12

ACCOUNTS FOR: 302	FOR: CAPITAL IMPROVEMENT	ORIGINAL APPROP	TRANFRS/ ADJSTMTS	REVISED BUDGET	YTD EXPENDED	ENCUMBRANCES	AVAILABLE BUDGET	PCT USED	
30215000	403300	17MNS CONTRACT SERV	-8,808	0	-8,808	4,550.22	.00	-13,357.74	-51.7%*
		TOTAL NEW MUNIS MODULES IMPLEMENTATI	-8,808	0	-8,808	4,550.22	.00	-13,357.74	-51.7%
17NRG ENERGY SAVINGS PROJECT									
30241500	403300	17NRG CONTRACT SERV	4,234,227	0	4,234,227	4,234,227.29	.00	.00	100.0%
30241500	403430	17NRG BOND ISSUANCE	0	0	0	.00	.00	.02	.0%
		TOTAL ENERGY SAVINGS PROJECT	4,234,227	0	4,234,227	4,234,227.29	.00	.02	100.0%
17PGR PLEASANT GROVE ROAD PAVING									
30271000	403300	17PGR CONTRACT SERV	98,000	0	98,000	.00	.00	98,000.00	.0%
		TOTAL PLEASANT GROVE ROAD PAVING	98,000	0	98,000	.00	.00	98,000.00	.0%
17PRB PALMYRA RESCUE BUILDING REPAIRS									
30241500	403300	17PRB CONTRACT SERV	1,922	4,092	6,014	6,013.90	.00	.00	100.0%
		TOTAL PALMYRA RESCUE BUILDING REPAIR	1,922	4,092	6,014	6,013.90	.00	.00	100.0%
17SBO SCHOOL BOARD OFFICE RENOVATIONS									
30265000	403300	17SBO CONTRACT SERV	97,524	200,000	297,524	98,937.69	.00	198,586.43	33.3%
		TOTAL SCHOOL BOARD OFFICE RENOVATION	97,524	200,000	297,524	98,937.69	.00	198,586.43	33.3%
17SIT SCHOOL INSTRUCTIONAL TECHNOLOGY									
30267000	408107	17SIT EDP EQUIPMENT	10,401	200,000	210,401	209,939.41	.00	461.24	99.8%
		TOTAL SCHOOL INSTRUCTIONAL TECHNOLOG	10,401	200,000	210,401	209,939.41	.00	461.24	99.8%



11/05/2018 11:34
5311epol

COUNTY OF FLUVANNA
FY18 Q4 YEAR-TO-DATE BUDGET REPORT

P 6
glytdbud

FOR 2018 12

ACCOUNTS FOR: 302 CAPITAL IMPROVEMENT	ORIGINAL APPROP	TRANFRS/ ADJSTMTS	REVISED BUDGET	YTD EXPENDED	ENCUMBRANCES	AVAILABLE BUDGET	PCT USED
<u>17TBR F&R TOUGHBOOK REPLACEMENT</u>							
30232500 408107 17TBR EDP EQUIPMENT	28,000	0	28,000	27,999.00	.00	1.00	100.0%
TOTAL F&R TOUGHBOOK REPLACEMENT	28,000	0	28,000	27,999.00	.00	1.00	100.0%
<u>17TBU TREASURER BUILDING UPGRADES</u>							
30241500 403300 17TBU CONTRACT SERV	108,168	150,000	258,168	276,252.57	.00	-18,084.27	107.0%*
30241500 408107 17TBU EDP EQUIPMENT	-1,395	0	-1,395	.00	.00	-1,394.78	.0%*
TOTAL TREASURER BUILDING UPGRADES	106,774	150,000	256,774	276,252.57	.00	-19,479.05	107.6%
<u>17TIC F&R THERMAL IMAGIING CAMERAS</u>							
30232500 408101 17TIC MACHINERY AND	0	50,400	50,400	39,121.00	.00	11,279.00	77.6%
TOTAL F&R THERMAL IMAGIING CAMERAS	0	50,400	50,400	39,121.00	.00	11,279.00	77.6%
<u>18BRN F&R BURN BUILDING</u>							
30232500 403100 18BRN PROFESSIONAL	30,000	0	30,000	.00	.00	30,000.00	.0%
30232500 403300 18BRN CONTRACT SERV	450,000	0	450,000	.00	.00	450,000.00	.0%
TOTAL F&R BURN BUILDING	480,000	0	480,000	.00	.00	480,000.00	.0%
<u>18CPR CPR ASSIST CHEST COMPRESSION SYSTEM</u>							
30232500 403300 18CPR CONTRACT SERV	14,736	0	14,736	14,735.50	.00	.00	100.0%
TOTAL CPR ASSIST CHEST COMPRESSION S	14,736	0	14,736	14,735.50	.00	.00	100.0%
<u>18CSF CARYSBROOK SOFTBALL FIELD</u>							
30271000 403300 18CSF CONTRACT SERV	25,000	0	25,000	8,550.00	.00	16,450.00	34.2%



11/05/2018 11:34
5311epol

COUNTY OF FLUVANNA
FY18 Q4 YEAR-TO-DATE BUDGET REPORT

P 7
glytdbud

FOR 2018 12

ACCOUNTS FOR: 302 CAPITAL IMPROVEMENT	ORIGINAL APPROP	TRANFRS/ ADJSTMTS	REVISED BUDGET	YTD EXPENDED	ENCUMBRANCES	AVAILABLE BUDGET	PCT USED
TOTAL CARYSBROOK SOFTBALL FIELD	25,000	0	25,000	8,550.00	.00	16,450.00	34.2%
<hr/>							
19CTH HISTORIC COURT HOUSE EXTERIOR RENOV							
30241500 403300 19CTH CONTRACT SERV	120,130	0	120,130	.00	.00	120,130.21	.0%
TOTAL HISTORIC COURT HOUSE EXTERIOR	120,130	0	120,130	.00	.00	120,130.21	.0%
<hr/>							
ADVEH ADMINISTRATION VEHICLES							
30242500 408105 ADVEH VEHICLE	14,915	75,000	89,915	71,845.00	.00	18,070.00	79.9%
TOTAL ADMINISTRATION VEHICLES	14,915	75,000	89,915	71,845.00	.00	18,070.00	79.9%
<hr/>							
BUSRS SCHOOL BUS CAPITAL RESERVE							
30264000 408105 BUSRS VEHICLE	1,146	700,000	701,146	452,145.00	.00	249,000.72	64.5%
TOTAL SCHOOL BUS CAPITAL RESERVE	1,146	700,000	701,146	452,145.00	.00	249,000.72	64.5%
<hr/>							
CR002 CAP RES HEALTH & SAFETY VIOLATIONS							
30241500 403300 CR002 CONTRACT SERV	7,821	-5,303	2,518	2,517.81	.00	.00	100.0%
TOTAL CAP RES HEALTH & SAFETY VIOLAT	7,821	-5,303	2,518	2,517.81	.00	.00	100.0%
<hr/>							
CR006 CAP RES COMMONWEALTH ATTY REPAIRS							
30241500 403300 CR006 CONTRACT SERV	27,708	0	27,708	.00	.00	27,708.32	.0%
TOTAL CAP RES COMMONWEALTH ATTY REPA	27,708	0	27,708	.00	.00	27,708.32	.0%
<hr/>							
CR007 CAP RES COURTS WATER HEATER							
30241500 403300 CR007 CONTRACT SERV	12,725	-10,741	1,984	1,984.47	.00	.00	100.0%



11/05/2018 11:34
5311epol

COUNTY OF FLUVANNA
FY18 Q4 YEAR-TO-DATE BUDGET REPORT

P 8
glytdbud

FOR 2018 12

ACCOUNTS FOR: 302	FOR: CAPITAL IMPROVEMENT	ORIGINAL APPROP	TRANFRS/ ADJSTMTS	REVISED BUDGET	YTD EXPENDED	ENCUMBRANCES	AVAILABLE BUDGET	PCT USED
	TOTAL CAP RES COURTS WATER HEATER	12,725	-10,741	1,984	1,984.47	.00	.00	100.0%
	CR009 CAP RES COURTHOUSE ROOF REPAIRS							
	30241500 403300 CR009 CONTRACT SERV	17,602	10,000	27,602	27,601.99	.00	.00	100.0%
	TOTAL CAP RES COURTHOUSE ROOF REPAIR	17,602	10,000	27,602	27,601.99	.00	.00	100.0%
	CR010 CAP RES 51 COURT SQUARE REPAIRS							
	30241500 403300 CR010 CONTRACT SERV	9,800	-50	9,750	9,750.00	.00	.00	100.0%
	TOTAL CAP RES 51 COURT SQUARE REPAIR	9,800	-50	9,750	9,750.00	.00	.00	100.0%
	CR011 CAP RES COURTS BUILD WELL REPAIRS							
	30241500 403300 CR011 CONTRACT SERV	7,800	0	7,800	1,473.01	.00	6,326.99	18.9%
	TOTAL CAP RES COURTS BUILD WELL REPA	7,800	0	7,800	1,473.01	.00	6,326.99	18.9%
	CR012 CAP RES BOBCAT SKDSTR LDR REPAIRS							
	30241500 403300 CR012 CONTRACT SERV	2,400	0	2,400	2,400.00	.00	.00	100.0%
	TOTAL CAP RES BOBCAT SKDSTR LDR REPA	2,400	0	2,400	2,400.00	.00	.00	100.0%
	CR013 CAP RES RECORD ROOM HVAC							
	30241500 403300 CR013 CONTRACT SERV	55,000	-3,949	51,051	51,051.25	.00	.00	100.0%
	TOTAL CAP RES RECORD ROOM HVAC	55,000	-3,949	51,051	51,051.25	.00	.00	100.0%
	CR014 CAP RES PALMYRA RESCUE ASPHALT							
	30241500 403300 CR014 CONTRACT SERV	39,000	0	39,000	39,000.00	.00	.00	100.0%



11/05/2018 11:34
5311epol

COUNTY OF FLUVANNA
FY18 Q4 YEAR-TO-DATE BUDGET REPORT

P 9
glytdbud

FOR 2018 12

ACCOUNTS FOR: 302 CAPITAL IMPROVEMENT	ORIGINAL APPROP	TRANFRS/ ADJSTMTS	REVISED BUDGET	YTD EXPENDED	ENCUMBRANCES	AVAILABLE BUDGET	PCT USED
TOTAL CAP RES PALMYRA RESCUE ASPHALT	39,000	0	39,000	39,000.00	.00	.00	100.0%
<hr/>							
CR015 CAP RES DEMO OLD MAINTENANCE SHOP							
30241500 403300 CR015 CONTRACT SERV	40,000	0	40,000	420.00	.00	39,580.00	1.1%
TOTAL CAP RES DEMO OLD MAINTENANCE S	40,000	0	40,000	420.00	.00	39,580.00	1.1%
<hr/>							
CR016 CAP RES FOUNDATION PG HOUSE							
30241500 403300 CR016 CONTRACT SERV	27,500	0	27,500	.00	.00	27,500.00	.0%
TOTAL CAP RES FOUNDATION PG HOUSE	27,500	0	27,500	.00	.00	27,500.00	.0%
<hr/>							
CR017 CAP RES PUBLIC SAFETY EVIDENCE STOR							
30241500 403300 CR017 CONTRACT SERV	8,550	0	8,550	6,550.00	.00	2,000.00	76.6%
TOTAL CAP RES PUBLIC SAFETY EVIDENCE	8,550	0	8,550	6,550.00	.00	2,000.00	76.6%
<hr/>							
CR018 CAP RES PUBLIC SFTY SECURE FENCING							
30241500 403300 CR018 CONTRACT SERV	15,000	3,880	18,880	18,880.00	.00	.00	100.0%
TOTAL CAP RES PUBLIC SFTY SECURE FEN	15,000	3,880	18,880	18,880.00	.00	.00	100.0%
<hr/>							
CR019 CAP RES PUBLIC SAFETY AC							
30241500 403300 CR019 CONTRACT SERV	37,500	0	37,500	.00	.00	37,500.00	.0%
TOTAL CAP RES PUBLIC SAFETY AC	37,500	0	37,500	.00	.00	37,500.00	.0%
<hr/>							
CTYRS COUNTY CAPITAL RESERVE							
30241500 403300 CTYRS CONTRACT SERV	128,908	102,214	231,122	.00	.00	231,121.54	.0%



11/05/2018 11:34
5311epol

COUNTY OF FLUVANNA
FY18 Q4 YEAR-TO-DATE BUDGET REPORT

P 10
glytdbud

FOR 2018 12

ACCOUNTS FOR: 302 CAPITAL IMPROVEMENT	ORIGINAL APPROP	TRANFRS/ ADJSTMTS	REVISED BUDGET	YTD EXPENDED	ENCUMBRANCES	AVAILABLE BUDGET	PCT USED
TOTAL COUNTY CAPITAL RESERVE	128,908	102,214	231,122	.00	.00	231,121.54	.0%
<u>FRVEH FIRE AND RESCUE VEHICLES</u>							
30232500 408105 FRVEH VEHICLE	38,981	60,000	98,981	57,304.70	.00	41,676.62	57.9%
TOTAL FIRE AND RESCUE VEHICLES	38,981	60,000	98,981	57,304.70	.00	41,676.62	57.9%
<u>RADIO RADIO COMMUNICATION</u>							
30232000 403300 RADIO CONTRACT SERV	447,987	0	447,987	361,875.94	.00	86,110.98	80.8%
30232000 403310 RADIO BLDGS EQUIP R	-1,022	0	-1,022	.00	.00	-1,022.42	.0%*
30232000 408102 RADIO FURNITURE & F	1,441	0	1,441	.00	.00	1,440.88	.0%
TOTAL RADIO COMMUNICATION	448,405	0	448,405	361,875.94	.00	86,529.44	80.7%
<u>SCFBR SCHOOLS FIBER INFRASTRUCTURE</u>							
30267000 403300 SCFBR CONTRACT SERV	298,475	0	298,475	123,324.33	.00	175,150.67	41.3%
TOTAL SCHOOLS FIBER INFRASTRUCTURE	298,475	0	298,475	123,324.33	.00	175,150.67	41.3%
<u>SCHRS SCHOOLS CAPITAL RESERVE</u>							
30265000 403300 SCHRS CONTRACT SERV	229,098	-99,743	129,355	.00	.00	129,354.85	.0%
TOTAL SCHOOLS CAPITAL RESERVE	229,098	-99,743	129,355	.00	.00	129,354.85	.0%
<u>SCHVH STUDENT TRANS AND FACILITY VEHICLES</u>							
30264000 408105 SCHVH VEHICLE	17	80,000	80,017	19,180.00	.00	60,836.99	24.0%
TOTAL STUDENT TRANS AND FACILITY VEH	17	80,000	80,017	19,180.00	.00	60,836.99	24.0%
<u>SHFRS SHERIFF VEHICLES CAPITAL RESERVE</u>							



11/05/2018 11:34
5311epol

COUNTY OF FLUVANNA
FY18 Q4 YEAR-TO-DATE BUDGET REPORT

P 11
glytddbud

FOR 2018 12

ACCOUNTS FOR: 302 CAPITAL IMPROVEMENT	ORIGINAL APPROP	TRANFRS/ ADJSTMTS	REVISED BUDGET	YTD EXPENDED	ENCUMBRANCES	AVAILABLE BUDGET	PCT USED
<u>30231000 408105 SHFRS VEHICLE</u>	4,260	160,000	164,260	161,384.40	.00	2,875.90	98.2%
TOTAL SHERIFF VEHICLES CAPITAL RESER	4,260	160,000	164,260	161,384.40	.00	2,875.90	98.2%
<u>SR009 CAP RES ENERGY PROJECT UNXPCTD CSTS</u>							
<u>30265000 403300 SR009 CONTRACT SERV</u>	3,500	5,536	9,036	9,036.00	.00	.00	100.0%
TOTAL CAP RES ENERGY PROJECT UNXPCTD	3,500	5,536	9,036	9,036.00	.00	.00	100.0%
<u>SR010 CAP RES BUS MOTOR REPLACEMENT</u>							
<u>30265000 403300 SR010 CONTRACT SERV</u>	20,000	0	20,000	20,000.00	.00	.00	100.0%
TOTAL CAP RES BUS MOTOR REPLACEMENT	20,000	0	20,000	20,000.00	.00	.00	100.0%
<u>SR011 CAP RES TENNIS & TRACK REPAIR</u>							
<u>30265000 403300 SR011 CONTRACT SERV</u>	44,400	-221	44,179	.00	.00	44,179.35	.0%
TOTAL CAP RES TENNIS & TRACK REPAIR	44,400	-221	44,179	.00	.00	44,179.35	.0%
<u>SR012 CAP RES FCHS BASEBALL BLEACHERS</u>							
<u>30265000 403300 SR012 CONTRACT SERV</u>	36,200	-424	35,776	35,775.60	.00	.00	100.0%
TOTAL CAP RES FCHS BASEBALL BLEACHER	36,200	-424	35,776	35,775.60	.00	.00	100.0%
<u>SR013 CAP RES FIRE EXTINGUISHERS</u>							
<u>30265000 403300 SR013 CONTRACT SERV</u>	7,980	-1,084	6,896	6,895.83	.00	.00	100.0%
TOTAL CAP RES FIRE EXTINGUISHERS	7,980	-1,084	6,896	6,895.83	.00	.00	100.0%
<u>SR014 CAP RES MIDDLE SCHOOL PAINTING</u>							



11/05/2018 11:34
5311epol

COUNTY OF FLUVANNA
FY18 Q4 YEAR-TO-DATE BUDGET REPORT

P 12
glytddbud

FOR 2018 12

ACCOUNTS FOR: 302 CAPITAL IMPROVEMENT	ORIGINAL APPROP	TRANFRS/ ADJSTMTS	REVISED BUDGET	YTD EXPENDED	ENCUMBRANCES	AVAILABLE BUDGET	PCT USED
<u>30265000 403300 SR014 CONTRACT SERV</u>	32,450	0	32,450	25,752.55	.00	6,697.45	79.4%
TOTAL CAP RES MIDDLE SCHOOL PAINTING	32,450	0	32,450	25,752.55	.00	6,697.45	79.4%
<u>SR015 CAP RES ROOF CARYSBROOK CENTRAL FCH</u>							
<u>30265000 403300 SR015 CONTRACT SERV</u>	8,770	-5,500	3,270	3,270.00	.00	.00	100.0%
TOTAL CAP RES ROOF CARYSBROOK CENTRA	8,770	-5,500	3,270	3,270.00	.00	.00	100.0%
<u>SR016 CAP RES CENTRAL ELEM WATER PIPE</u>							
<u>30265000 403300 SR016 CONTRACT SERV</u>	35,599	-5,077	30,522	30,521.99	.00	.00	100.0%
TOTAL CAP RES CENTRAL ELEM WATER PIP	35,599	-5,077	30,522	30,521.99	.00	.00	100.0%
<u>SR017 CAP RES CENTRAL ELEM SCHOOL LEAK</u>							
<u>30265000 403300 SR017 CONTRACT SERV</u>	8,550	-50	8,500	.00	.00	8,500.00	.0%
TOTAL CAP RES CENTRAL ELEM SCHOOL LE	8,550	-50	8,500	.00	.00	8,500.00	.0%
<u>SR018 CAP RES FCHS BAL/CALIBRATE AIR UNIT</u>							
<u>30265000 403300 SR018 CONTRACT SERV</u>	7,888	0	7,888	.00	.00	7,888.00	.0%
TOTAL CAP RES FCHS BAL/CALIBRATE AIR	7,888	0	7,888	.00	.00	7,888.00	.0%
<u>SR019 CAP RES FCHS MAIN WATER LINE REPAIR</u>							
<u>30265000 403300 SR019 CONTRACT SERV</u>	8,259	0	8,259	8,258.74	.00	.26	100.0%
TOTAL CAP RES FCHS MAIN WATER LINE R	8,259	0	8,259	8,258.74	.00	.26	100.0%
<u>SSVEH SOCIAL SERVICES VEHICLE CAPITAL RES</u>							

11/05/2018 11:34
5311epol

COUNTY OF FLUVANNA
FY18 Q4 YEAR-TO-DATE BUDGET REPORT

P 13
glytdbud

FOR 2018 12

ACCOUNTS FOR: 302	CAPITAL IMPROVEMENT	ORIGINAL APPROP	TRANFRS/ ADJSTMTS	REVISED BUDGET	YTD EXPENDED	ENCUMBRANCES	AVAILABLE BUDGET	PCT USED
30242500	408105 SSVEH VEHICLE	2,893	21,700	24,593	14,430.00	.00	10,163.00	58.7%
TOTAL SOCIAL SERVICES VEHICLE CAPITA		2,893	21,700	24,593	14,430.00	.00	10,163.00	58.7%
TOTAL CAPITAL IMPROVEMENT		10,964,523	1,956,509	12,921,032	9,244,000.42	.00	3,677,031.33	71.5%
TOTAL EXPENSES		10,964,523	1,956,509	12,921,032	9,244,000.42	.00	3,677,031.33	

3.1.10. Reappropriation of Balances (Carryovers)

- A. Appropriations lapse on June 30, for all unencumbered budget items other than capital projects and grants.
- B. All outstanding encumbrances, both operating and capital, as of fiscal year-end shall be automatically reappropriated to the subsequent fiscal year to the same department and account for which they were encumbered in the previous fiscal year.
- C. All capital reserve appropriations shall be automatically reappropriated to the subsequent fiscal year to the same department and account for which they were originally appropriated.
- D. All unencumbered balances for capital projects shall remain appropriations until the completion of the capital project or until the Board of Supervisors, by appropriate resolution, changes or eliminates the appropriation.
- E. All supplemental appropriations approved within a fiscal year for a specific purpose or project shall be automatically reappropriated to the subsequent fiscal year and utilized to complete original purpose or project as identified in the board action
- F. External school funding shall be reappropriated to the subsequent fiscal year upon receipt of approval by the funding agency. School administration is required to notify the county Finance Department of such approval no later than August 30th of the subsequent fiscal year in which the funding is to be reappropriated. This excludes the local general fund appropriation, which requires the school board or superintendent of schools to submit a formal request for carryover to the Board of Supervisors.
- G. Those amounts necessary for the continuation of unencumbered operating projects or services may be requested by departments, amended by the County Administrator and adopted, with any changes, by the Board of Supervisors to be reappropriated to the budget of the next fiscal year. Such requests for reappropriation shall be for specifically defined projects that could not reasonably be started prior to June 30.

County of Fluvanna

Carryover Request FY18/19

Office/Department: Cooperative Extension

General Ledger Account Title	FY18 Org Code	FY18 Object Code	FY19 Org Code (If Different)	FY19 Object Code (If Different)	Amount Requested	Justification: <u>Please answer all three questions. Why should these funds be carried forward?</u> Why was the project not completed within FY18? If this request is denied, what impact will it have on this Office/Department's ability to function efficiently?
1 Contract Services	10084000	403300			\$ 14,600.00	The kitchen renovation project at the Community Center was initiated in 2016, and was not completed due to a lack of funds for equipment. In FY2017, there were not funds available to complete the project again. In FY 18, there were dollars allocated to a position that was not filled. If this request is denied, the kitchen will remain un-rentable to the public yet again (the intention of the original project). (Estimated quotes for dishwasher- \$6102.77, freezer-\$3834, ice maker \$4180.71 plus installation)
2	10084000	VARIES	10084000	403310	\$ 4,300.00	Additional storage is needed for the Extension office. The basement storage area of the Fluvanna Community Center has experienced water intrusion frequently in 2017 and 2018. Additionally, it is difficult to carry large items from the basement storage due to the stairwell and steps. There were not funds available for this project in 2017. In FY 18, there were dollars allocated to a position that was not filled. If this request is denied, items will continue to accumulate in the meeting room of room 4, as well as in the office area. Requesting carryover of funds for a storage shed to be housed at Fluvanna Community Center.Total of \$4300 requested from the following lines: 403300- \$2,101; 406003-\$614; 405540-\$471; 405810-\$210; 405230-\$412; 405410-\$104; 406001-\$189; 406014-\$199
3						
4						
5						
6						
Office/Department: Cooperative Extension					Total Carryover Amount Requested: \$ 18,900.00	

County of Fluvanna

Carryover Request FY18/19

Office/Department: E-911 - FCSO

General Ledger Account Title	FY18 Org Code	FY18 Object Code	FY19 Org Code (If Different)	FY19 Object Code (If Different)	Amount Requested	Justification: <u>Please answer all three questions. Why should these funds be carried forward?</u> Why was the project not completed within FY18? If this request is denied, what impact will it have on this Office/Department's ability to function efficiently?
1 Overtime Pay	10032000	401310			\$ 6,000.00	We went live with our new CAD on June 6th. We would like to hold best practices training since we have been live for a few months to make our CO's more efficient. Did not have time to complete this before FY-18 ended. Would have to use OT from current budget which may be needed for emergency coverage, but the " refresher" training will need to be completed either way.
2 Maintenance Contracts	10032000	403320			\$ 8,000.00	Increase storage space on our server to expand the new CAD system storage. We have transitioned to a paperless RMS system with the new CAD. We did not know the storage needs of the new system until we have been live for a few months. If not transferred will have to try to make find money in the current budget to handle the needed upgrade to ensure our systems run effectively
3 Telecommunications	10032000	405230			\$ 5,000.00	The new CAD system has integration with IOS products for end users in the field. Would purchase iPads for investigators/Command Staff that do not have Mobile Data Terminals so they can do reports and log evidence from the field. Would attempt to find money during this year to fund the project which may not be available, this would increase the efficiency of our officers in the field.
4 IT Services	1003200	403125			\$ 7,000.00	Upgrade remaining Windows 7 computers in the office. With CAD implementation and system building we weren't able to get this completed during the FY. If denied would have to find the money elsewhere as the new software functions more efficiently on Windows 10.
5						
6						
Office/Department: E-911 - FCSO					Total Carryover Amount Requested: \$ 26,000.00	

County of Fluvanna

Carryover Request FY18/19

Office/Department: FIRE & RESCUE

General Ledger Account Title	FY18 Org Code	FY18 Object Code	FY19 Org Code (If Different)	FY19 Object Code (If Different)	Amount Requested	Justification: <u>Please answer all three questions.</u> Why should these funds be carried forward? Why was the project not completed within FY18? If this request is denied, what impact will it have on this Office/Department's ability to function efficiently?
1 F&R Capital	10032500	405626	10032500	405626	\$ 175,000.00	Lake Monticello Brush 50 was approved and ordered in FY18. Apparatus will not be completed and delivered until FY19.
2						
3						
4						
5						
6						
Office/Department: FIRE & RESCUE					Total Carryover Amount Requested: \$ 175,000.00	

County of Fluvanna

Carryover Request FY18/19

Office/Department: **PARKS & REC.**

General Ledger Account Title	FY18 Org Code	FY18 Object Code	FY19 Org Code (If Different)	FY19 Object Code (If Different)	Amount Requested	Justification: <u>Please answer all three questions.</u> Why should these funds be carried forward? Why was the project not completed within FY18? If this request is denied, what impact will it have on this Office/Department's ability to function efficiently?
1 Site Improvement	10071000	409904			\$ 4,000.00	These funds were to be used to grade/level Carysbrook softball field's infield along with the backstop work to the field. The wet weather has not allowed us to move the dirt to grade/level the infield. If denied, the work will have to wait until additional funding is approved for the project.
2						
3						
4						
5						
6						

Office/Department: **PARKS & REC.**

Total Carryover Amount Requested: \$ 4,000.00

County of Fluvanna

Carryover Request FY18/19

Office/Department: REGISTRAR

General Ledger Account Title	FY18 Org Code	FY18 Object Code	FY19 Org Code (If Different)	FY19 Object Code (If Different)	Amount Requested	Justification: <u>Please answer all three questions.</u> Why should these funds be carried forward? Why was the project not completed within FY18? If this request is denied, what impact will it have on this Office/Department's ability to function efficiently?
1 Contract Services	10017000	403300			\$ 5,000.00	Needed to print an additional 13,000 ballots because of additional meals tax referendum. Previous ballots did not have referendum on there. These funds will help cover the additional cost of reprinting.
2						
3						
4						
5						
6						
Office/Department: REGISTRAR					Total Carryover Amount Requested: \$ 5,000.00	

County of Fluvanna

Carryover Request FY18/19

Office/Department:

General Ledger Account Title	FY18 Org Code	FY18 Object Code	FY19 Org Code (If Different)	FY19 Object Code (If Different)	Amount Requested	Justification: Please answer all three questions. Why should these funds be carried forward? Why was the project not completed within FY18? If this request is denied, what impact will it have on this Office/Department's ability to function efficiently?
10031000				403310	\$ 30,076.71	The sally port entrance for prisoners is non-secure and dangerous for deputies, prisoners and the visiting public of the Sheriff's office. In addition to that upgrade, the secure evidence Connex box remains unusable in its uncompleted state of construction. The sally port and evidence solution construction were not completed, as funding for the continued upgrade of the Sheriff's office were depleted. If these funds are not authorized, our sally port will continue to be a high-risk area, vulnerable to potentially fatal threats. In addition, our evidence process remains out of compliance with the desired handling and storage standards, which impacts this agency daily.
10031000				405540	\$ 8,000.00	The training of our staff is of the utmost importance in today's ever-changing and increasingly litigious society. We need to continue our enhanced training plan for supervisors, commanders, and specialized functions that could not be completed as the funding was depleted prior to full implementation with all of our focus staff. Without the funding to continue this process, we will remain exposed to potential gaps and other inefficiencies in protecting the public, and safeguarding our staff.
10031000				406010	\$ 3,800.00	(1) We started the Project Lifesaver program a few years ago and we currently provide location services for five (5) high-risk individuals with intellectual or memory disorders and have others waiting to participate. If this request is denied, we would not be able as quickly or possibly safely locate those that wander. This will cause our agency to use more staff and resources to address searches of these types of incidents, especially, when someone goes missing.
10031000				406010		(2) We had a plan to replace our Tasers regularly, but the company is no longer guaranteeing the older Tasers, if we use them. This has caused us to be limited in the use of the Taser, as we had to remove all of our old Tasers from use. The Taser provides certified deputies a less lethal weapon as an alternative to physical force in many situations.
10035000			10031000	403300	\$ 2,904.15	The FSPCA building is the contractual pound for the county animal control issues, and it is in need of emergency electrical supply of a permanent generator. This was not completed over the last year as did not have enough funds to provide this necessary enhancement. If denied, the project would continue to make the emergency care of our domestic more complicated, and less dependable in times of crisis for the shelter and Sheriff's office staff.
Office/Department:					Total Carryover Amount Requested: \$ 44,780.86	

**FLUVANNA COUNTY BOARD OF SUPERVISORS
AGENDA ITEM STAFF REPORT**

TAB T

MEETING DATE:	November 20, 2018				
AGENDA TITLE:	Department of Forestry Pole Shed Lease				
MOTION(s):	I move that the board adopt the attached resolution authorizing the County to enter into a deed of lease with the Department of Forestry for a fire dozer/transport garage pole shed at Carysbrook, 8838 James Madison Hwy, Fork Union, and that the County Administrator be authorized to execute such deed of lease on behalf of the County, subject to approval as to form by the County Attorney.				
STRATEGIC INITIATIVE?	Yes	No	If yes, list initiative(s):		
		X			
AGENDA CATEGORY:	Public Hearing	Action Matter	Presentation	Consent Agenda	Other
		XX			
STAFF CONTACT(S):	Fred Payne, County Attorney, and Steve Nichols, County Administrator				
PRESENTER(S):	Steve Nichols, County Administrator				
RECOMMENDATION:	Approval				
TIMING:	Immediate				
DISCUSSION:	<p>The Virginia Department of Forestry wants to use a Fluvanna County parcel to build a storage building to be used for storage and maintenance of vehicles, equipment, and materials used for firefighting and fire prevention.</p> <p>The new VDOF Building would go on the site of the former maintenance building recently demolished at Carysbrook. It is intended that the Department will construct and maintain improvements on the property. There is to be no cash rent, in light of the benefits to the citizens of the County from the Department's use of the property. The initial term is to be for 25 years, with provisions made for renewals of 5 years each.</p> <p>The parcel is not required for any current County use and the County will benefit by having the firefighting and fire prevention equipment maintained locally.</p>				
FISCAL IMPACT:	The dollar value of the property is minimal.				
POLICY IMPACT:	None				
LEGISLATIVE HISTORY:	None				
ENCLOSURES:	Agreement Exhibit A - DOF Fluvanna Site Plan Final Exhibit B - DOF Fluvanna Building Plan Single Door 12.1.2017				

	Exhibit C - DOF Fluvanna Resolution				
REVIEWS COMPLETED:	Legal	Finance	Purchasing	HR	Other
	x				

After recording, please return to:
Commonwealth of Virginia
Department of Forestry
Attn: Joseph Schaefer
900 Natural Resources Drive
Suite 800
Charlottesville, VA 22903

Prepared under the supervision of the
Office of the Attorney General of Virginia

Parcel ID: 42-1-4A

This Lease is exempt from taxation pursuant to Va. Code §§ 58.1-811(A)(3), 58.1-811(E), and the Clerk's fee pursuant to Va. Code §§ 17.1-266, 17.1-279(E).

Deed of Lease

This DEED OF LEASE (the "Lease") is dated the _____ day of _____ 2018, between the COUNTY OF FLUVANNA, a political subdivision of the Commonwealth of Virginia as GRANTOR ("Landlord"), in accordance with § 15.2-1800 of the Code of Virginia (1950) as amended, and the COMMONWEALTH OF VIRGINIA, DEPARTMENT OF FORESTRY, as GRANTEE ("Tenant"), with approval of the Governor pursuant to § 2.2-1149 of the Code of Virginia (1950), as amended.

WITNESSETH

1. **PREMISES.** For and in consideration of the terms, conditions, covenants, promises and agreements herein made, Landlord leases to Tenant the following property or premises (the "Premises"), together with rights of ingress and egress to and from the adjacent public road, in the County of Fluvanna, Virginia. The Premises are more particularly described as:

Approximately 3,750 square feet of land, being a portion of the property identified as Fluvanna County Tax Parcel 42-1-4A, having an address of 8838 James Madison Hwy., Fork Union, Virginia 23055, and located on that certain tract or parcel of land, acquired by the Landlord herein by deed dated May 9, 1985, of record in the Office of the Clerk of Fluvanna County, Virginia in Deed Book 161, page 429. The above referenced portion of real estate is more particularly shown and described on that certain plan entitled "VIRGINIA DEPARTMENT OF FORESTRY FIRE DOZER/TRANSPORT GARAGE POLE SHED STRUCTURES, VARIOUS LOCATIONS STATEWIDE, FLUVANNA COUNTY LOCATION," Sheet C106, dated January 10, 2018, prepared by The Lane Group (the "Site Plan"), attached hereto as Exhibit A, and made a part hereof.

Landlord warrants that Landlord alone, at the time this Lease is executed, has the right to lease the Premises, without the consent of any other party. It is expressly understood and agreed that this covenant by the Landlord constitutes a warranty. If Landlord does not have this right, then Tenant, in addition to any other remedy available at law or in equity, may immediately declare this Lease null and void from its inception and of no force and effect, without notice.

2. **USE OF PREMISES.** The Premises shall be used for storage and maintenance of vehicles, equipment, and materials used for firefighting and fire prevention.
3. **TERM.** The initial term of this Lease (the "Initial Term") shall be Twenty-Five (25) years, beginning on _____, 2018 (the "Commencement Date"), and terminating on _____, 2043 (the "Termination Date").
4. **RENT.**
 - (a) Landlord accepts as full and adequate consideration for this lease of the Premises the benefits to the residents of the County of Fluvanna to accrue by reason of the public purposes to which the Premises shall be used by Tenant; thus, no rent will be charged.
 - (b) No security deposit shall be required.
5. **POSSESSION AND CONDITION OF PREMISES.**
 - (a) Landlord shall deliver quiet possession of the Premises to Tenant on the Commencement Date and shall provide quiet enjoyment of the Premises to Tenant during the Initial Term, and any renewals or extensions thereof.
 - (b) Landlord, and its employees, agents and contractors, shall have the right to enter and pass through any part of the Premises only in the case of an emergency or with Tenant's consent. If Landlord, or Landlord's employees, agents or contractors, must enter the Premises in the case of an emergency, then as soon as practicable before or after such emergency entrance, Landlord, or Landlord's agent, shall contact Senior Area Forester David Powell (Telephone number 434-981-0439). If this primary contact person is not reached, then Landlord, or Landlord's agent, shall contact Regional Forester Robbie Talbert (Telephone number 434-960-0880). Landlord, or Landlord's agent, shall continue to make reasonable attempts to communicate with Tenant until contact is made. Either of these contact persons may be changed by proper notice to Landlord.
 - (c) Landlord represents and warrants that the Premises are zoned for uses that include the permitted uses set out in Section 2 hereof. Landlord makes no other representation or warranty as to the suitability of the Premises for the purposes permitted in Section 2.

- (d) During the Initial Term and any extensions or renewals thereof, Landlord shall not impose upon the Premises any restrictions, easements or agreements that would diminish or interfere with Tenant's use permitted under this Lease.
 - (e) Tenant shall not at any time use, generate, store, release or dispose of, on, under or about the Premises any Hazardous Substance except in compliance with applicable laws. For the purposes of this covenant, the term "Hazardous Substance" shall mean (i) any "hazardous waste" as defined by the Resource Conservation and Recovery Act of 1976 (42 U.S.C. § 6901, *et seq.*), as amended, and regulations promulgated thereunder; (ii) any "hazardous substance" as defined by the Comprehensive Environmental Response, Compensation, and Liability Act of 1980 (42 U.S.C. § 9601, *et seq.*), as amended, and regulations promulgated thereunder; (iii) petroleum and petroleum-based products; (iv) asbestos in any quantity or form which would be subjected to regulation under any applicable environmental statutes, ordinances, or regulations; (v) polychlorinated biphenyls; (vi) any substance, the presence of which on the Property is prohibited by any environmental statute, ordinance, or regulation affecting the Property; and (vii) any other substance which, by any environmental statute, ordinance, or regulation affecting the Property, requires special handling in its collection, storage, treatment, or disposal. Tenant shall be responsible for the cost of any required or necessary remediation, repair, clean-up or detoxification and the preparation of any closure or other required plans, to the full extent that such action is attributable, directly or indirectly, to the use, generation, storage, release or disposal of any Hazardous Substance on the Premises at any time by Tenant in violation of applicable laws. Landlord represents and warrants that no Hazardous Substance is located on the Premises as of the Commencement Date. Landlord shall not at any time during the term of this Lease use, generate, store, release or dispose of, on, under or about the Premises any Hazardous Substance. Landlord shall be responsible for the cost of any required or necessary remediation, repair, clean-up or detoxification and the preparation of any closure or other required plans, to the full extent that such action is attributable, directly or indirectly, to any Hazardous Substance located on the Premises as of the Commencement Date or arising out of the use, generation, storage, release or disposal of any Hazardous Substance on the Premises at any time by any party other than the Tenant.
6. **IMPROVEMENTS.** Tenant, at its sole cost and expense, may make improvements to the Premises as Tenant deems proper, including those improvements shown on Exhibit A and Exhibit B attached hereto ("Tenant's Improvements"). Tenant is authorized to conduct site examinations, soil borings, geotechnical, and engineering studies to evaluate the feasibility of the Premises for the Tenant's Improvements. Tenant shall obtain all necessary permits and approvals with respect to the Tenant's Improvements. All improvements to be made by the Tenant shall comply with all applicable law, including, without limitation, the standards of the Uniform Statewide Building Code. Tenant shall at all times maintain the Premises in a safe and sanitary condition, as well as in good repair. Landlord shall cooperate with Tenant in obtaining any such permits and approvals, but

with no obligation upon Landlord to expend its funds. The title to and ownership of the Tenant's Improvements shall remain in Tenant. Upon termination of this Lease, Tenant may, at its option, remove the Tenant's Improvements, in which event Tenant shall restore the Premises to its condition prior to the Commencement Date. If Tenant elects not to remove the Tenant's Improvements, it shall have no further responsibility for them or their removal. If Tenant does not remove the Tenant's Improvements within one hundred eighty (180) days of termination of this Lease, title to and ownership of the Tenant's Improvements shall vest in Landlord.

7. **UTILITIES AND SERVICES.** Tenant shall be responsible for providing and paying for all utilities and services required at the Premises. Landlord shall permit and approve such temporary (for the duration of this Lease) access agreements and easements as may be required to provide utilities and services to Tenant at the Premises, at no cost to Landlord.

8. **DISCLOSURES; NON-WAIVER; APPROPRIATIONS.**

- (a) The parties understand and acknowledge that Tenant is an agency of the Commonwealth of Virginia, and with respect to tort liability for acts or occurrences on or about the Premises, including product liability, the Commonwealth and Tenant are either (i) constitutionally immune (or partially immune) from suit, judgment or liability, (ii) insured, or (iii) covered by a financial plan of risk management that is in the nature of self-insurance, all as determined by applicable laws, government policies and practices.
- (b) The parties understand and acknowledge that neither party has agreed to provide any indemnification or save harmless agreements running to the other party. No provision, covenant or agreement contained in this Lease shall be deemed to be a waiver of the sovereign immunity of the Commonwealth of Virginia, Landlord, or Tenant from tort or other liability.
- (c) This Lease shall be governed by, and construed according to, the laws of the Commonwealth of Virginia. The parties choose the City of Richmond, Virginia, as the venue for any action instituted pursuant to the terms of this Lease.
- (d) Notwithstanding any other provision of this Lease, if Tenant shall cease to exist, and is not replaced by a successor entity with similar powers and purposes, or its powers and authority are limited so as to not permit the continued use of the Premises for its intended purpose and use, then this Lease shall terminate. In such event, Tenant will endeavor to give as much notice as is reasonably possible of the event triggering the termination and the anticipated date by which Tenant will completely vacate the Premises. Nevertheless, if Tenant, in its sole discretion, determines that another agency or institution of the Commonwealth has a need for the Premises, Tenant may assign the Lease to such other agency or institution, subject to the prior written consent of the Landlord, which consent shall not be unreasonably withheld or delayed.

- (e) Agencies of the Commonwealth of Virginia cannot expend funds unless appropriated by the Virginia General Assembly and may not obligate a future session of the Virginia General Assembly. Therefore, notwithstanding any provision in this Lease to the contrary, if any session of the Virginia General Assembly fails to appropriate funds for the continuation of this Lease, this Lease and all obligations hereunder shall automatically terminate upon depletion of the then currently appropriated or allocated funds. Tenant agrees to provide Landlord sixty (60) days' written notice of such non-appropriation and impending termination. This provision shall apply even though no rent is being charged by Landlord, due to the costs that the Tenant will need to expend to use and maintain the Premises.

9. CONDEMNATION.

- (a) Landlord shall give immediate notice to Tenant of any discussions, offers, negotiations or proceedings with any party regarding condemnation or taking of any portion of the Premises.
- (b) If any portion of the Premises is taken by eminent domain or sold to the holder of such power pursuant to a threatened taking (exclusive of takings that, in the reasonable discretion of Tenant, do not materially adversely affect the use and enjoyment of the Premises by Tenant), this Lease shall terminate effective as of the date of the taking. The date of taking shall be the earlier of: (i) the date on which title vests in the condemning entity or (ii) the date on which the condemning entity takes possession. In the event of a taking, Tenant assigns to Landlord any rights that Tenant may have in and to any portion of a condemnation award, but such an assignment shall exclude any portion that may be due for, or attributed to, Tenant's fixtures, moving expenses and allowances.

10. OPTION, TERMINATION, RENEWAL, AND HOLDOVER.

- (a) Renewal. This Lease shall automatically renew and continue for a term of Five (5) years ("Renewal Term") on the same terms and conditions as existed immediately prior to the commencement of the Renewal Term if neither party has given a timely notice of termination as provided in (b) below. At the end of any Renewal Term, this Lease shall again automatically renew and continue for an additional Renewal Term of Five (5) years on the same terms and conditions as existed immediately prior to the commencement of the Renewal if neither party has given a timely notice of termination as provided in (b) below.
- (b) Termination. Unless otherwise terminated herein, Landlord or Tenant may elect to terminate this Lease at the end of the Initial Term or any Renewal Term upon providing a minimum of six (6) months' written notice to the other party prior to the expiration of the Initial Term or any Renewal Term as may be applicable.

- (c) Holdover. If Tenant continues to occupy the Premises after the termination as provided in (b) above (“Holdover”), such Holdover shall be deemed a tenancy from month-to-month upon the same terms and conditions as existed immediately prior to the commencement of the Holdover. Either party may terminate such holdover upon providing a minimum of thirty (30) days prior written notice to the other party.

11. NOTICES.

- (a) All notices to Tenant required or permitted under this Lease shall be given in any manner set out in subsection (c) of this Section, to Tenant addressed to:

Virginia Department of Forestry
 900 Natural Resources Drive, Suite 800
 Charlottesville, Virginia 22903
 Attn: Chief of Administration

- (b) All notices to Landlord required or permitted under this Lease shall be given in any manner set out in subsection (c) of this Section, to Landlord addressed to:

County of Fluvanna
 P.O. Box 540
 Palmyra, Virginia 22963
 Attn: County Administrator

With a copy to:

Frederick W. Payne
 Fluvanna County Attorney
 414 E. Jefferson St
 Charlottesville, Virginia 22902

- (c) Any notices required or permitted to be given hereunder shall be deemed to have been properly given if sent by (i) United States certified or registered mail, return receipt requested, postage prepaid; (ii) a nationally recognized overnight delivery service using next day delivery; or (iii) personal delivery. Notices sent by (i) the United States Postal Service shall be deemed delivered two (2) days after being deposited with the United States Postal Service; (ii) notices delivered by a nationally recognized overnight delivery service using next business day delivery shall be deemed delivered the business day after depositing with such carrier; and (iii) hand delivered notices shall be deemed delivered upon actual delivery to the recipient.
- (d) Each party to this Lease shall notify the other party of a new address to which to provide notice, which notice shall be given in the manner provided above, and unless and until such notice of a new address is given, notices to a party hereto shall be sufficient if provided to such party’s address as specified in this Section.

12. **BINDING EFFECT; AMENDMENTS.** The covenants, agreements, and rights contained in this Lease shall bind and inure to the respective successors and assigns of Landlord and Tenant. This Lease constitutes the entire, full and complete understanding and agreement between Landlord and Tenant, and all representations, statements, warranties, covenants, promises or agreements previously made or given by either party to the other are expressly merged into this Lease and shall be null, void and without legal effect. Neither party, nor any agent of either party, has any authority to alter, amend or modify any of the terms of this Lease, unless the amendment is in writing and executed by all parties to this Lease with the same formality as this Lease. This Lease shall not be effective or binding unless and until signed by all parties and Tenant obtains the recommendation of the Virginia Department of General Services and the approval of the Governor of Virginia, or his designee, as required by § 2.2-1149 of the Code of Virginia (1950), as amended.
13. **DEFAULT.**
- (a) The termination of this Lease by Tenant pursuant to the provisions contained herein shall not be a default hereunder.
 - (b) If either party shall breach any provision of this Lease, the non-breaching party shall give written notice thereof to the breaching party. The breaching party shall have thirty (30) days from the receipt of the notice to cure the breach and, if not so cured, the non-breaching party may, at its option, exercise such rights as may exist at law or in equity, except that Landlord shall not take possession of the Premises by any self-help remedy. The provisions of this subsection shall not be construed as imposing any additional obligations on the non-breaching party to the extent that this Lease permits the non-breaching party to take certain actions as a result of a breach by the other party.
14. **PRESUMPTIONS.** No presumption shall be created in favor of or against any of the parties to this Lease with respect to the interpretation of any term or provision of this Lease due to the fact that this Lease, or any part hereof, was prepared by or on behalf of one of the parties hereto, as may be evidenced by the disclosure on the face of this Deed of Lease made pursuant to § 17.1-223 of the Code of Virginia (1950), as amended.
15. **ASSIGNMENT.** Tenant may not assign this Lease, or sublet the Premises, without the written consent of Landlord, which consent shall not be unreasonably withheld or delayed, except that Tenant may assign this Lease to any other agency or institution of the Commonwealth of Virginia without Landlord's consent.
16. **HEADINGS.** The heading of the sections of this Lease are inserted for convenience only and do not alter or amend the provisions that follow such headings.

17. **ADDITIONAL PROVISIONS.** This Lease is subject to the following terms, conditions, modifications, additions and/or deletions provided in the following designated attachments, exhibits and riders, which are hereby incorporated into this Deed of Lease:

Exhibits: A Site Plan
 B Building Plan
 C Resolution authorizing execution of this Lease by Landlord

The remainder of this page is intentionally left blank.

IN WITNESS WHEREOF, the parties hereto have affixed their signatures and seals.

LANDLORD: COUNTY OF FLUVANNA
a political subdivision of the Commonwealth of Virginia

By: _____
Steven M. Nichols
County Administrator

COMMONWEALTH OF VIRGINIA
COUNTY OF FLUVANNA, to wit:

The foregoing Deed of Lease was acknowledged before me this ____ day of _____ 2018, by Steven M. Nichols acting in his capacity as County Administrator for the County of Fluvanna, on behalf of the County.

My commission expires: _____
Registration No. _____

Notary Public

Approved as to form this ___ day of _____ 2018:

By: _____
Mr. Frederick W. Payne, County Attorney

TENANT: COMMONWEALTH OF VIRGINIA,
DEPARTMENT OF FORESTRY

By: _____
Robert W. Farrell
State Forester

COMMONWEALTH OF VIRGINIA
COUNTY OF ALBEMARLE, to wit:

The foregoing Deed of Lease was acknowledged before me this _____ day of _____ 2018, by Robert W. Farrell acting in his capacity as the State Forester of the Commonwealth of Virginia, Department of Forestry, on behalf of the agency.

My commission expires: _____
Registration No. _____

Notary Public

RECOMMEND APPROVAL:
DEPARTMENT OF GENERAL SERVICES

By: _____
Director

APPROVED BY THE GOVERNOR:

Pursuant to § 2.2-1149 of the Code of Virginia (1950), as amended, and as the official designee of the Governor of Virginia, as authorized and designated by Executive Order 88 (01) dated December 21, 2001, I hereby approve the acquisition of the Premises pursuant to this Deed of Lease for and on behalf of the Governor of Virginia.

Secretary of Administration

Date

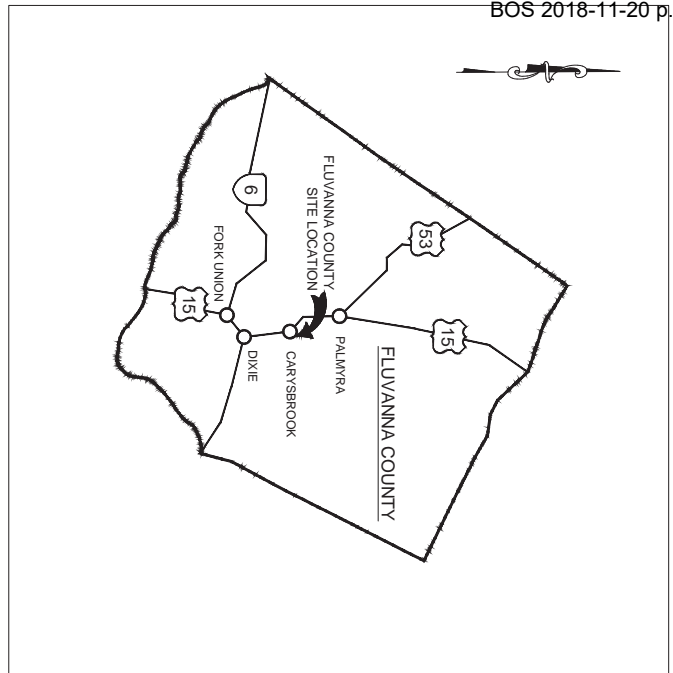

LOCATION MAP
NOT TO SCALE



VICINITY MAP
SCALE: 1" = 100'

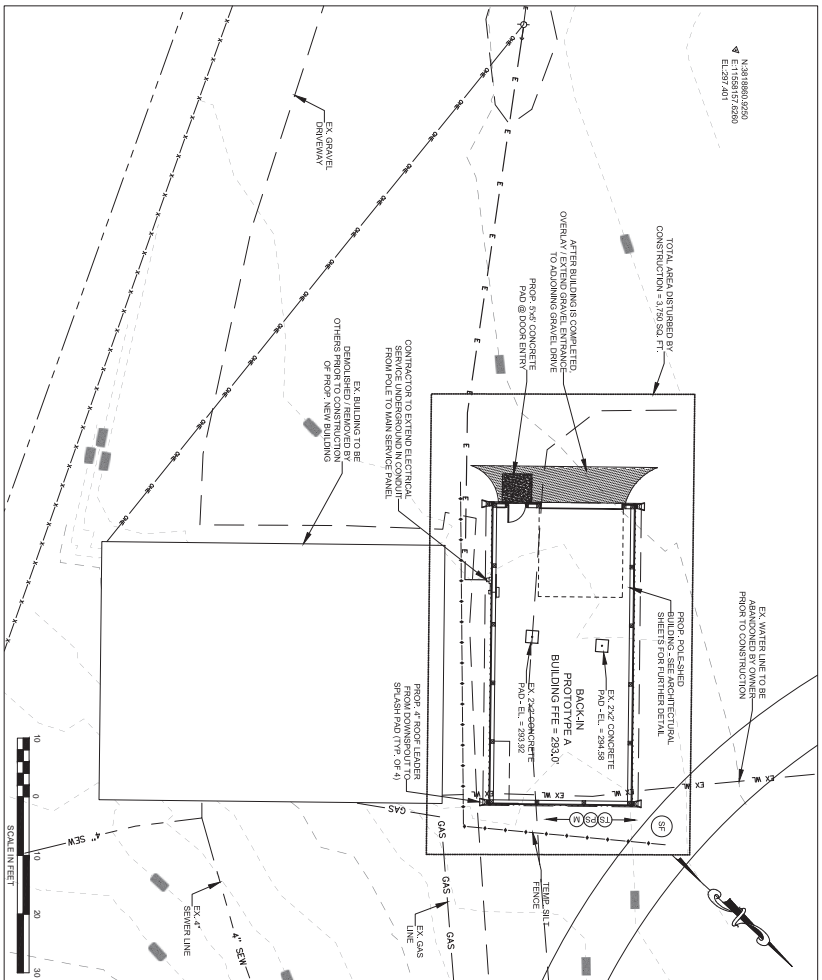

ENLARGED SITE PLAN
SCALE: 1" = 10'

- GENERAL CONSTRUCTION NOTES:**
1. THE CONTRACTOR SHALL CONTACT RESPONSIBILITY AT 1.800.502.2001 AND/OR LOCAL UTILITY OWNERS / OPERATORS AND HAVE ALL UTILITIES MARKED AT LEAST 72 HOURS PRIOR TO ANY EXCAVATION IN THE AREA OF EXISTING IMPROVEMENTS.
 2. THE PROPOSED BUILDING LAYOUT AND DIMENSIONS SHOWN ARE GENERAL IN NATURE. SEE ARCHITECTURAL SHEETS FOR DIMENSIONS.
 3. SITE PREP WORK SHALL BE DONE TO REMOVE EXISTING SPRAWLS AND PREPARE PROPOSED WATER. ALL DISTURBED AREAS SHALL BE RESTORED WITH FINISHED SURFACE BEING GRASS OR GRAVEL AS INDICATED ON THE PLANS.
 4. PRIOR TO STARTING CONSTRUCTION THE CONTRACTOR SHALL INSTALL A PERMITS BATTLE FENCE FOR EROSION CONTROL. AFTER THE SITE IS STABILIZED THE TEMPORARY BATTLE FENCE SHALL BE REMOVED.
 5. THE PROPOSED WORK IS ANTICIPATED TO DISTURB LESS THAN 10,000 SQUARE FEET. SO ANY EROSION AND SEDIMENTATION CONTROL MEASURES TO PROTECT THE WORK AND ADJACENT AREAS DURING THE CONSTRUCTION PERIOD.

NO.	REVISION/DATE
1	10/24/2018
2	
3	

C106

DATE: 10/24/2018

CONTRACTOR: MSA

PROJECT: C106

SCALE: 1" = 100'

FLUVANNA COUNTY LOCATION

VIRGINIA DEPARTMENT OF FORESTRY
FIRE DOZER/TRANSPORT GARAGE
POLE SHED STRUCTURES
PC#: 411-18151-006

the LANE GROUP

engineering
architecture
surveying
environmental

119 North Main Street
Galax, Virginia 24333
276.236.4558 - office
276.236.0458 - fax

Abingdon I Big Stone Gap I Galax
www.thelanegroupinc.com

PC#: 411-18151-006

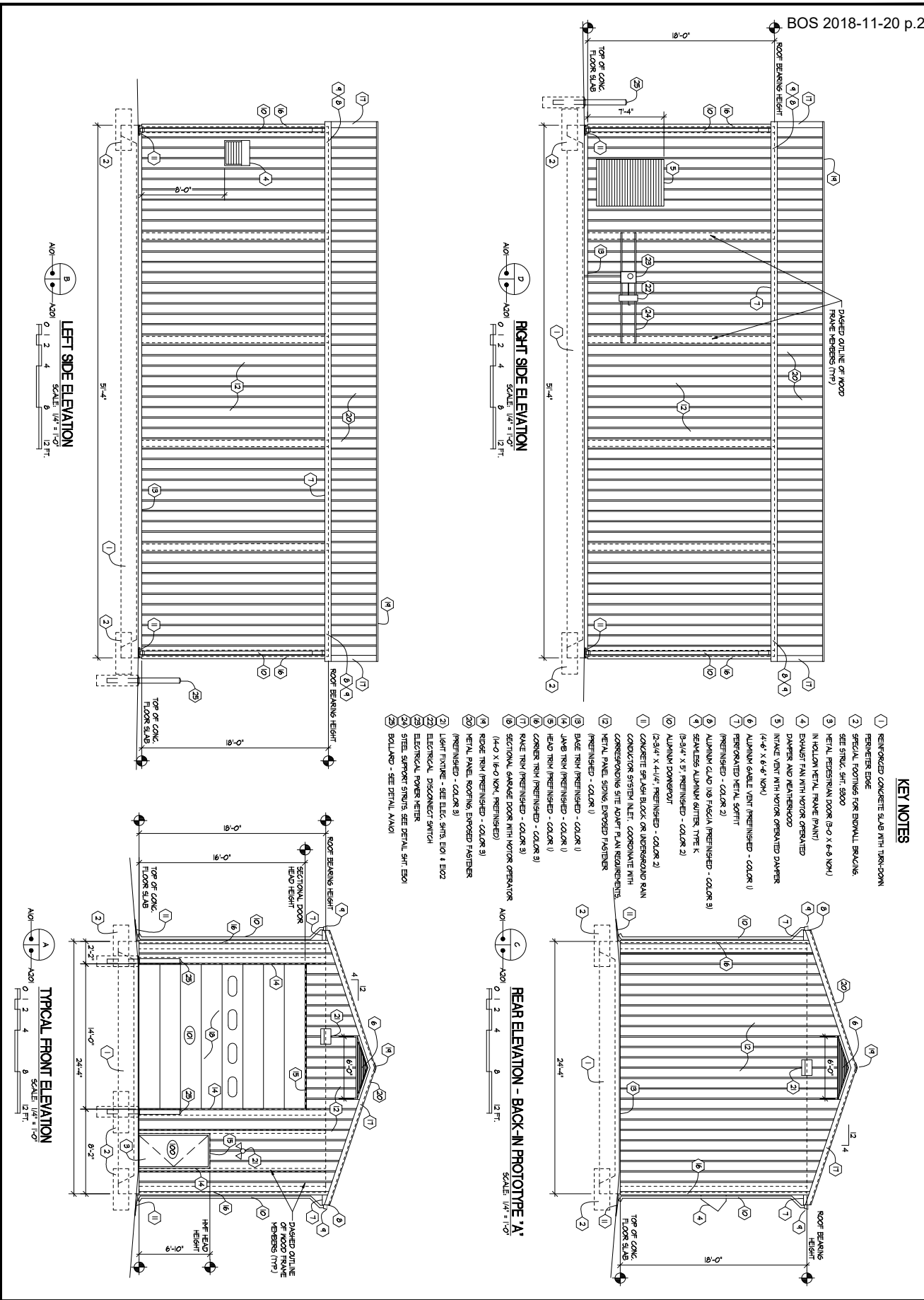

SHEET: A201 I&R_A201.dwg	DATE: November 1, 2017	VIRGINIA DEPARTMENT OF FORESTRY FIRE DOZER / TRANSPORT GARAGE PROTOTYPE POLE SHED STRUCTURES VARIOUS LOCATIONS STATEWIDE		P24_411-951-000	THE LANE GROUP 113 NORTH MAIN STREET • GALAX, VA 24333 P: 757.236.4588 WWW.THELANEGROUPINC.COM
	NO. 1 REVISION:				

EXHIBIT C

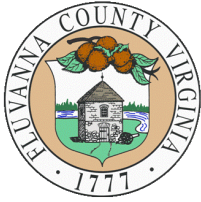

BOARD OF SUPERVISORS

County of Fluvanna

Palmyra, Virginia

RESOLUTION No. 16-2018

RESOLUTION FOR LEASE OF SPACE TO THE DEPARTMENT OF FORESTRY FOR A POLE SHED

WHEREAS the Department of Forestry of the Commonwealth wishes to establish a pole shed for the storage and maintenance of certain vehicles, equipment and materials for firefighting and fire prevention; and

WHEREAS the Board recognizes the value to the citizens of the County of the establishment of such a facility;

NOW THEREFORE BE IT RESOLVED BY THE BOARD OF SUPERVISORS OF FLUVANNA COUNTY that the County enter into a deed of lease with the Department of Forestry for the construction and maintenance of a pole shed for the purposes aforesaid pursuant to Virginia Code Sec. 15.2-1800-B (i), the terms of which are set forth in the attached form of deed of lease;

AND BE IT FURTHER RESOLVED that the County Administrator be, and he is hereby, authorized to execute the same on behalf of the County, subject to the approval as to form by the County Attorney.

THE FOREGOING RESOLUTION WAS DULY AND REGULARLY ADOPTED by the Fluvanna County Board of Supervisors at the Regular Meeting of the Board held on the 20th day of November, 2018, on a motion by _____, seconded by _____, and by the following vote:

AYES: Booker, Eager, Sheridan, Weaver

NAYS: None

ABSENT: O'Brien

A copy teste:

Clerk of the Board of Supervisors

**FLUVANNA COUNTY BOARD OF SUPERVISORS
AGENDA ITEM STAFF REPORT**

TAB U

MEETING DATE:	November 20, 2018				
AGENDA TITLE:	Resolution Recommending Appointment to the Board of Equalization				
MOTION(s):	I move the Board of Supervisors adopt a resolution entitled, "A RESOLUTION RECOMMENDING APPOINTMENT TO THE BOARD OF EQUALIZATION."				
STRATEGIC INITIATIVE?	Yes	No	If yes, list initiative(s):		
		X			
AGENDA CATEGORY:	Public Hearing	Action Matter	Presentation	Consent Agenda	Other
	XX				
STAFF CONTACT(S):	Steven M. Nichols, County Administrator				
PRESENTER(S):	Steven M. Nichols, County Administrator				
RECOMMENDATION:	Approve				
TIMING:	Current				
DISCUSSION:	The Board selected five nominees for the 2019 Board of Equalization at the Nov 7, 2018, meeting. By administrative oversight, the required resolution was not in the package.				
	The attached Resolution directs submission of the nominees for Circuit Court consideration and formal appointment and provides direction for making admin support available to the BOE.				
FISCAL IMPACT:	N/A				
POLICY IMPACT:	N/A				
LEGISLATIVE HISTORY:	N/A				
ENCLOSURES:	<ul style="list-style-type: none"> • Resolution 				
REVIEWS COMPLETED:	Legal	Finance	Purchasing	HR	Other
	X				

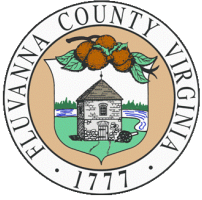

BOARD OF SUPERVISORS

County of Fluvanna
Palmyra, Virginia

RESOLUTION No. 17-2018

**A RESOLUTION RECOMMENDING APPOINTMENT TO
THE BOARD OF EQUALIZATION**

WHEREAS, Virginia Code Section 58.1-3370 requires the appointment of a Board of Equalization in each tax year immediately following the year a general reassessment is conducted in the County; and

WHEREAS, it is the desire of the Board of Supervisors of Fluvanna County to request that the Circuit Court of the County appoint such a Board and to suggest to the court the members to be appointed; and

WHEREAS, the Board of Supervisors desires to provide necessary clerical assistance for such Board of Equalization in accordance with Virginia Code Section 58-1-3376; and

WHEREAS, a general reassessment of the County has recently been completed; and

WHEREAS, the Fluvanna County Board of Supervisors requests the Board of Equalization to meet as frequently as necessary to hear all appeals from landowners concerning their reassessment; and

WHEREAS, the Fluvanna County Board of Supervisors encourages the Board of Equalization to meet with the assessors and review and evaluate their method of assessing the value of land in this reassessment.

NOW, THEREFORE BE IT RESOLVED by the Board of Supervisors of Fluvanna County, as follows:

- 1) That the County Attorney be, and he is hereby, **DIRECTED** to request the appointment by the Circuit Court of the County of a Board of Equalization as required by law; and that, in so doing, the County Attorney submit to the court a suggested list of members for such Board of Equalization, such list being attached to this resolution as Exhibit A; and
- 2) That the County Administrator be, and he is hereby, **AUTHORIZED AND DIRECTED** to provide necessary clerical assistance for such Board of Equalization, by the hiring of additional personnel or otherwise providing support as may be necessary; and
- 3) That the Commissioner of the Revenue be, and he is hereby, **REQUESTED** to assist such Board of Equalization.

THE FOREGOING RESOLUTION WAS DULY AND REGULARLY ADOPTED by the Fluvanna County Board of Supervisors at a meeting of the Board held on the 20th day of November, 2018, on a motion by _____, seconded by _____, and by the following vote:

AYE: NAY: ABSENT:

Attest:

John M. Sheridan, Chair
Fluvanna County Board of Supervisors

FLUVANNA COUNTY BOARD OF SUPERVISORS
AGENDA ITEM STAFF REPORT

TAB V

MEETING DATE:	November 20, 2018				
AGENDA TITLE:	CRA PROJECT AGREEMENT # 1 - FLUVANNA COUNTY BUILDING AND PROGRAM FEASIBILITY STUDY AND ASSESSMENT				
MOTION(S):	<p><u>Motion #1:</u> I move the Board of Supervisors approve a supplemental appropriation of \$10,690 from the BOS Contingency budget to the CIP project budget for the Countywide Building Assessment, to increase the funds necessary for Project Agreement 1.</p> <p><u>Motion #2:</u> I move the Board of Supervisors to approve Project Agreement # 1 between Fluvanna County and Crabtree, Rohrbaugh & Associates to complete the Fluvanna County Building and Program Feasibility Study and Assessment totaling \$32,550.00, and further authorize the County Administrator to execute the agreements subject to approval as to form by the County Attorney.</p>				
STRATEGIC INITIATIVE?	Yes	No	If yes, list initiative(s):		
		X			
AGENDA CATEGORY:	Public Hearing	Action Matter	Presentation	Consent Agenda	Other
		X			
STAFF CONTACT(S):	Cyndi Toler, Purchasing Officer				
PRESENTER(S):	Cyndi Toler, Purchasing Officer				
RECOMMENDATION:	Recommend approval				
TIMING:	Routine				
DISCUSSION:	<ul style="list-style-type: none"> ❖ Currently in the County CIP, there is \$21,860 set aside for a Countywide Building Assessment. An additional \$10,690 is being requested to increase the CIP funding for the project. ❖ The purpose of this is to explore options for renovating existing County facilities, repurposing external facilities and/or constructing a new building(s) to consolidate county services to improve internal functionality and service to the public. Also we will gain valuable insight for CIP planning in coming years. ❖ The total scope of work will include: <ul style="list-style-type: none"> ➤ 1. Assessment of existing physical conditions of buildings and systems ➤ 2. Evaluate age, condition and remaining life of facilities and systems ➤ 3. Identification of systems that will need repair, replacement or upgrade ➤ 4. Building code compliance review, including ADA accessibility ➤ 5. Maintenance recommendations ➤ 6. Operational / Program recommendations ➤ 7. Renovation / construction options ➤ 8. Scope of work and costs for all recommendations ➤ 9. Categorize and Prioritize recommendations ❖ CRA will survey existing facilities and give a condition assessment on each, including a replacement timeline and potential costs for improvement. The facilities to be evaluated are: <ul style="list-style-type: none"> ➤ 1. Courthouse ➤ 2. County Administration ➤ 3. Commissioner of Revenue 				

	<ul style="list-style-type: none"> ➤ 4. Treasurer ➤ 5. Voter Registrar ➤ 6. Public Works ➤ 7. Commonwealth's Attorney ➤ 8. Library ➤ 9. Social Services ➤ 10. Sheriff's office ➤ 11. Fork Union Community Center ➤ 12. School Board Office <ul style="list-style-type: none"> ❖ They will also meet with staff in order to get a better idea of needs and workflow. ❖ They will then draft recommendations to the county for improvements, plans, renovations or new construction options, and program realignments. 				
FISCAL IMPACT:	❖ An additional \$10,690 is being requested to increase the CIP funding for the project.				
POLICY IMPACT:	N/A				
LEGISLATIVE HISTORY:	N/A				
ENCLOSURES:	❖ PROJECT AGREEMENT # 1 FLUVANNA COUNTY BUILDING AND PROGRAM FEASIBILITY STUDY AND ASSESSMENT				
REVIEWS COMPLETED:	Legal	Finance	Purchasing	HR	Other
	X	X	X		

PROJECT AGREEMENT # 1
TERM CONTRACT BETWEEN COUNTY AND ARCHITECT/ENGINEER FOR
PROFESSIONAL SERVICES
FLUVANNA COUNTY BUILDING AND PROGRAM FEASIBILITY STUDY AND
ASSESSMENT

This Project Agreement #1 (the "Project Agreement") made this ____ day of _____, 2018, between Fluvanna County, Virginia (the "County"), a political subdivision of the Commonwealth of Virginia, and Crabtree, Rohrbaugh & Associates, Inc. (the "Consultant"), a Pennsylvania corporation authorized to transact business in Virginia, is an addendum to that TERM CONTRACT BETWEEN COUNTY AND ARCHITECT/ENGINEER FOR PROFESSIONAL SERVICES dated the 25th day of October, 2018 (including all exhibits, and as modified by any amendments or addendums thereto the "Agreement"). All defined terms in the Agreement shall have the same meaning in this Project Agreement unless the context used herein requires otherwise.

Whereas, pursuant to the Agreement the County shall issue written task orders to the Consultant as services are needed;

Whereas the Consultant submitted a Proposal for "Fluvanna County Building and Program Feasibility Study and Assessment" dated November 12, 2018, ("the Proposal") which is attached hereto as Exhibit 1 and incorporated by reference herein as a material part of this Project Agreement;

Whereas, the County desires that the Consultant complete all those services listed in the Proposal, including, but not limited to, those services and associated deliverables described in the Proposal (the "Task order Services" or the "Services");

Whereas, the Consultant desires to accept the work and complete the Task Order Services and all work necessary and related thereto (the "Task Order").

For good and valuable consideration, the parties hereby agree as follows:

ARTICLE I: THE AGREEMENT

The foregoing recitations are incorporated by reference into this Project Agreement.

This Project Agreement is an addendum to and made a material part of the Agreement. The parties hereto agree that except as specifically and expressly modified hereby that Agreement remains in full force and effect and the provisions of the Agreement are incorporated herein and are a material part hereof.

ARTICLE II: TASK ORDER

Consultant shall provide all work and services necessary or desired to complete Services on the Task Order consistent with all provisions of this Project Agreement, Exhibit 1 and the Agreement.

The County's project manager for technical inquiries relating to this Project Agreement shall be:

Mr. Eric Dahl
Deputy County Administrator/Director of Finance
132 Main Street
Palmyra, VA 22963
Phone: (434) 591-1930
E-mail: edahl@fluvannacounty.org

Billing inquiries should be directed to Cyndi Toler, Purchasing Officer, whose contact information appears below in Article VI.

ARTICLE III: EXHIBITS AND RESOLVING CONFLICTS

The rights and duties of the County and Consultant applicable to the County's projects under this Project Agreement are set forth in the following Agreement Documents:

- (i) This Project Agreement;
- (ii) Exhibit 1 hereto;
- (iii) The Agreement including exhibits thereto; and
- (iv) The County of Fluvanna General Terms Conditions and Instructions to Bidders and Contractors, being a portion of Attachment 1 which is attached to and a part of the Agreement.

Whenever possible, the terms of the above Agreement Documents shall be read together, however in the event of a conflict, the order of preference above shall govern which Agreement Document will control. In other words, (i) shall control over (ii) to (iii) above, and (ii) shall control over (iii).

ARTICLE IV: FEES

Notwithstanding anything to the contrary contained in Exhibit 1 hereto, the Consultant shall be paid hourly for their work based upon the rates set forth in Exhibit 3 to the Agreement and up to the following not-to-exceed flat fees for the Task Order Services:

- ONE THOUSAND EIGHT HUNDRED SIXTY NO/100 DOLLARS (\$1,860.00) for that part of the Additional Services described as the "Review of Existing Documentation"; and
- EIGHT THOUSAND NINE HUNDRED NINETY AND NO/100 DOLLARS (\$8,990.00) for that part of the Additional Services described as the "Survey of Existing Facilities" ; and
- NINE THOUSAND NINE HUNDRED TWENTY AND NO/100 DOLLARS (\$9,920.00) for that part of the Additional Services described as the "Draft Condition Assessment of each Building" ; and
- TWO THOUSAND FOUR HUNDRED EIGHTY AND NO/100 DOLLARS

- (\$2,480.00) for that part of the Additional Services described as the “Staff interviews” ; and
- ONE THOUSAND TWO HUNDRED FORTY AND NO/100 DOLLARS (\$1,240.00) for that part of the Additional Services described as the “Development of Initial Program and Adjacencies” ; and
 - ONE THOUSAND TWO HUNDRED FORTY AND NO/100 DOLLARS (\$1,240.00) for that part of the Additional Services described as the “Workshop / Establish Project Priorities” ; and
 - THREE THOUSAND ONE HUNDRED AND NO/100 DOLLARS (\$3,100.00) for that part of the Additional Services described as the “Develop a list of the Projects / Program Options” ; and
 - THREE THOUSAND SEVEN HUNDRED TWENTY AND NO/100 DOLLARS (\$3,720.00) for that part of the Additional Services described as the “Final Improvement Program and Project / Program Option Report” ;

The not-to-exceed fees indicated above and on Exhibit 1 attached hereto are all based on a Senior Project Manager completing the work at a rate of \$155 per hour. Notwithstanding that, the actual hourly fees charged by the Contactor for the Services will be based on the rates set forth on Exhibit 3 to the Agreement and will vary based upon the person completing the Services (for example, \$65 per hour for “Architectural Staff”, and \$155 per hours for a “Senior Project Manager”).

The flat fees are not-to exceed amounts. The the hourly fees up to the not-to-exceed total per task shall be payable by the County upon proper invoice by the Consultant as described herein. No invoice may be provided by the Consultant to the County until the Task Order is complete and all items or services purchased have been delivered to, inspected by and accepted by the County. The Consultant may invoice the County only when the entire Task Order is complete. The Consultant will be paid within forty-five (45) days of receipt of a proper invoice following final acceptance of all work on the Task order by the County in its sole discretion. The flat fee includes all fees, costs and charges of any kind to perform all the services and work, including supplying at its own cost and expense any necessary tools, equipment or materials, necessary or desirable for completion of the task specified.

ARTICLE V: TERM

Consultant shall with due diligence and dispatch assiduously pursue this Task Order to completion, but in any event such Services and work being a part of the Task Order must be completed to the sole satisfaction of the County on or before the 28th day of February, 2019. Time being of the essence.

ARTICLE VI: MISCELLANEOUS

As appropriate to the context, the singular will include the plural and vice versa, and reference to one gender will include the others. This Project Agreement may be executed in one or more counterparts, each of which will be considered the Project Agreement for all purposes of proof. In addition to allowing electronic signatures upon an electronic copy of this Project Agreement, as provided by Virginia law, facsimile signatures upon any signature page will be considered to be original signatures. This Project Agreement contains the entire understanding of the parties with respect to the subject matter hereof and is to be modified only by a writing signed by the parties to this Project Agreement. This Project Agreement will be binding upon and inure to the benefit of the respective parties and their successors. This Project Agreement is not assignable by either party, except by operation of law. The legal address for the County and for the Consultant and the addresses for delivery of Notices and other documents related to the administration of this Project Agreement are as follows:

County

ATTN: Cyndi Toler, Purchasing Officer
Fluvanna County
P.O. Box 540
Palmyra, VA 22963
Telephone (434) 591-1930
FAX (434) 591-1911

Consultant

Crabtree, Rohrbaugh & Associate
ATTN: Joshua C. Bower, AIA, LEED AP BD+C, GGP
250 West Main St Suite 200
Charlottesville, VA 22902
Telephone (866) 458-0272

Any party may substitute another address for the one set forth above by giving a notice in the manner required. Any notice given by mail will be deemed to be received on the fifth (5th) day after deposit in the United States mail. Any notice given by hand will be deemed to be received when delivered. Notice by courier will be deemed to have been received on the date shown on any certificate of delivery.

[Signature page to follow.]

In witness whereof the undersigned duly authorized representatives have executed this Project Agreement on the dates set forth beside their respective signatures.

Consultant:
Crabtree, Rohrbaugh & Associate

County:
Fluvanna County

By: _____ Date: _____ By: _____ Date: _____

Name: _____ Name: _____

Title: _____ Title: _____

Approved as to form:

Fluvanna County Attorney



November 12, 2018

Board of Supervisors
County of Fluvanna
132 Main St.
Palmyra, VA 22963

Re: Fluvanna County Building and Program Feasibility Study and Assessment

Dear Board of Supervisors:

Crabtree, Rohrbaugh & Associate is pleased to submit our proposal to complete a County Wide Building and Program Feasibility and Assessment for Fluvanna County. Our collaborative process combined with our client-oriented approach results in providing Fluvanna County the highest quality planning and design services along with unrivaled personal attention and project control. Our scope of work includes the following:

1. Assessment of existing physical conditions of buildings and systems
2. Evaluate age, condition and remaining life of facilities and systems
3. Identification of systems that will need repair, replacement or upgrade
4. Building code compliance review, including ADA accessibility
5. Maintenance recommendations
6. Operational / Program recommendations
7. Renovation / construction options
8. Scope of work and costs for all recommendations
9. Categorize and Prioritize recommendations

The feasibility study and assessment will include the following buildings, vacant County owned land and potential properties for sale:

1. Courthouse
2. County Administration
3. Commissioner of Revenue
4. Treasurer
5. Voter Registrar
6. Public Works
7. Commonwealth's Attorney
8. Library
9. Social Services
10. Sheriff's office
11. Fork Union Community Center
12. School Board Office

Project Schedule and Architectural / Engineering Services Fee per phase (approximately 2-3 months):

1. Kick-Off Meeting

A kickoff meeting conducted to discuss and plan the assessment process, identify and qualify the goals and objectives of the assessment and to insure that the process meets the specific needs of Fluvanna County. (Completed)

2. Prepare Inventory of Existing Facilities

The inventory will also include information on the year the facility was built or acquired, the date of last improvement, its condition, the extent of use, and any scheduled dates for rebuilding or expansion.

3. Review of Existing Documentation

Review of all relevant Facilities & Maintenance information, County Planning information, Community Development information, and County budget information.

Architectural Fee (6 hours @ \$155.00/hr)	\$930.00
M.P.E. Engineering Fee (6 hours @ \$155.00/hr)	\$930.00
Subtotal	\$1,860.00

4. Survey of Existing Facilities

This will include a complete a thorough analysis of existing facilities. The goals will be to collect, coordinate, analyze and prioritize facility, infrastructure needs.

Architectural Fee (18 hours @ \$155.00/hr)	\$2,790.00
Structural Engineering Fee (4 hours @ \$155.00/hr)	\$620.00
M.P.E. Engineering Fee (36 hours @ \$155.00/hr)	\$5,580.00
Subtotal	\$8,990.00

5. Draft Condition Assessment of each Building

A Condition Assessment Report will be completed for all facilities including replacement timeline and potential costs for improvement.

Architectural Fee (12 hours @ \$155.00/hr)	\$1,860.00
Structural Engineering Fee (4 hours @ \$155.00/hr)	\$620.00
M.P.E. Engineering Fee (48 hours @ \$155.00/hr)	\$7,440.00
Subtotal	\$9,920.00

6. Staff interviews

Program meetings with Fluvanna County officials, administration, and department heads.

Architectural Fee (16 hours @ \$155.00/hr)	\$2,480.00
Subtotal	\$2,480.00

7. Development of Initial Program and Adjacencies

Create a program of spaces with all existing areas and adjacencies. Develop a list of needs for each program and ideal adjacencies.

Architectural Fee (8 hours @ \$155.00/hr)	\$1,240.00
Subtotal	\$1,240.00

8. Workshop / Establish Project Priorities

A Stakeholder review of all existing information gathered to date, as well as project recommendations and requests should be conducted at this workshop. Each option should ultimately be evaluated in relation to other projects to determine their relative importance.

Architectural Fee (8 hours @ \$155.00/hr)	\$1,240.00
Subtotal	\$1,240.00

9. Develop a list of the Projects / Program Options

Based upon the work completed to date, a draft of the recommended improvements plan, renovations or new construction options, and program realignment will be prepared for review and coordination with the County.

Architectural Fee (20 hours @ \$155.00/hr)	\$3,100.00
Subtotal	\$3,100.00

10. Final Improvement Program and Project / Program Option Report

Based upon the review and feedback on the Improvements and Options, the final report will provide a comprehensive list of Capital Improvements, Program Recommendations and Project Options for review by Fluvanna County Board of Supervisors.

Architectural Fee (12 hours @ \$155.00/hr)	\$1,860.00
M.P.E. Engineering Fee (12 hours @ \$155.00/hr)	\$1,860.00
Subtotal	\$3,720.00

Total Architectural and Engineering Study Fee: \$32,550.00

*The above timeline and hours is not intended to limit the amount of time expended on the Feasibility Study and Assessment, but is intended to state the expected time to be spent based on similar projects of this scope.

*The study will include a digital PDF copy of the entire report and editable excel CIP and FCI spreadsheets.

We again thank you for the opportunity to submit our proposal and if you should have any questions or comments, please feel free to contact me at any time (434) 975 7262.

Sincerely,

CRABTREE, ROHRBAUGH & ASSOCIATES – ARCHITECTS



Joshua C. Bower, AIA, LEED AP BD+C, GGP
Principal | Senior Project Manager

**FLUVANNA COUNTY BOARD OF SUPERVISORS
AGENDA ITEM STAFF REPORT**

TAB W

MEETING DATE:	November 20, 2018				
AGENDA TITLE:	VPSA Series 2012 Escrow Earnings				
MOTION(s):	N/A				
TIED TO STRATEGIC INITIATIVES?	Yes	No	If yes, list initiative(s):		C7
	XX				
AGENDA CATEGORY:	Public Hearing	Action Matter	Presentation	Consent Agenda	Other
	XX				
STAFF CONTACT(S):	Eric Dahl, DCA/Finance Director				
PRESENTER(S):	Eric Dahl, DCA/Finance Director				
RECOMMENDATION:	Information only.				
TIMING:	Current.				
DISCUSSION:	To provide an update on the VPSA Series 2012 Escrow Savings Opportunity.				
FISCAL IMPACT:	N/A				
POLICY IMPACT:	N/A				
LEGISLATIVE HISTORY:	N/A				
ENCLOSURES:					
REVIEWS COMPLETED:	Legal	Finance	Purchasing	HR	Other

**FLUVANNA COUNTY BOARD OF SUPERVISORS
AGENDA ITEM STAFF REPORT**

TAB XYZ

MEETING DATE:	Nov 20, 2018				
AGENDA TITLE:	Adoption of the Fluvanna County Board of Supervisors Oct 17, 2018 Meeting Minutes.				
MOTION(s):	I move the meeting minutes of the Fluvanna County Board of Supervisors Regular Meeting on Wednesday, October 17, 2018, be adopted.				
STRATEGIC INITIATIVE?	Yes	No	If yes, list initiative(s):		
		X			
AGENDA CATEGORY:	Public Hearing	Action Matter	Presentation	Consent Agenda	Other
				XX	
STAFF CONTACT(S):	Kelly Belanger Harris, Clerk to the Board				
PRESENTER(S):	Steven M. Nichols, County Administrator				
RECOMMENDATION:	Approve				
TIMING:	Routine				
DISCUSSION:	None.				
FISCAL IMPACT:	N/A				
POLICY IMPACT:	N/A				
LEGISLATIVE HISTORY:	None				
ENCLOSURES:	Draft Minutes for October 17, 2018				
REVIEWS COMPLETED:	Legal	Finance	Purchasing	HR	Other

**FLUVANNA COUNTY BOARD OF SUPERVISORS
REGULAR MEETING MINUTES
Circuit Court Room
October 17, 2018
Regular Meeting 7:00pm**

MEMBERS PRESENT: John M. (Mike) Sheridan, Columbia District, Chair
Mozell Booker, Fork Union District, Vice Chair
Patricia Eager, Palmyra District
Tony O’Brien, Rivanna District
Donald W. Weaver, Cunningham District

ABSENT: None.

ALSO PRESENT: Steven M. Nichols, County Administrator
Fred Payne, County Attorney
Kelly Belanger Harris, Clerk for the Board of Supervisors

1 - CALL TO ORDER, PLEDGE OF ALLEGIANCE, & MOMENT OF SILENCE

At 7:00pm Chair Sheridan called to order the Regular Meeting of October 17, 2018. After the recitation of the Pledge of Allegiance, a moment of silence was observed.

3 - ADOPTION OF AGENDA

MOTION

Mr. Weaver moved to accept the Agenda, for the October 17, 2018 Regular Meeting of the Board of Supervisors. Mrs. Booker seconded and the Agenda was adopted by a vote of 5-0. AYES: Sheridan, Booker, Eager, O’Brien, and Weaver. NAYS: None. ABSENT: None.

4 - COUNTY ADMINISTRATOR’S REPORT

Mr. Nichols reported on the following topics:

- Community and County Staff Recognitions
 - Congratulations to Mrs. Mozell Booker for receiving the “John E. Baker Legacy Award”, recognizing an individual whose life work has emphasized the importance of quality education for all children in Albemarle County and the City of Charlottesville. She received the award at the 8th Annual John E. Baker Legacy Dinner on October 5 at Farmington Country Club. The annual dinner is dedicated to raising funds to increase the number of African American teachers in local public schools.
 - Fluvanna County High School has earned the Blue Star School Award for 2018 for WISE Financial Literacy
 - Fluvanna County High School Football – Record now 6-1 for the season!
 - Light Academy Ribbon Cutting/Cunningham Homecoming held Sunday, Oct 14th
 - School Security Equipment Grant Awarded - \$52,000 for Fluvanna Middle School
- Announcements and Updates
 - Daily Progress Report - “Local housing market humming along”
 - Parks and Recreation Activities
 - 14th Annual Halloween Festival, Oct 27, 2018, 5:00pm – 8:00pm
 - Teen Night at Ashlawn Clubhouse, Lake Monticello, Oct 20, 2018, 7:00pm – 10:00pm
 - October is Domestic Violence Awareness Month
- Upcoming Meetings

Day	Date	Time	Purpose	Location
Wed	Nov 7	4:00 PM	BOS Regular Meeting	Courtroom
Tue	Nov 20	7:00 PM	BOS Regular Meeting	Courtroom
Wed	Dec 5	4:00 PM	BOS Regular Meeting	Courtroom
		7:00 PM	Work Session - FCPS and County Preliminary Budget Discussion	Courtroom
Wed	Dec 19	4:00 PM	Budget Work Session – Non-Profit Presentations	Courtroom
		7:00 PM	BOS Regular Meeting	Courtroom

5 - PUBLIC COMMENTS #1

At 7:08pm Chair Sheridan opened the first round of Public Comments.

With no one else wishing to speak, Chair Sheridan closed the first round of Public Comments at 7:08pm.

6 - PUBLIC HEARING

Zoning Text Amendment ZTA 18:05—Brad Robinson, Senior Planner brought forward a request to amend the Fluvanna County Zoning Ordinance to increase gross residential density in the R-3 District subject to a special use permit. Mr. Robison noted that the 2015 Comprehensive Plan encourages a residential density of 10 dwelling units per acre (du/ac) in the Zion Crossroads Community Planning Area and 6 du/ac in the Rivanna Community Planning Area. However, the highest density currently allowed by the zoning ordinance is 2.9 du/ac in the R-3, Residential Planned Community District. This density can be a significant restraint for multi-family residential uses. The proposed amendment adds a provision to increase density in the R-3 zoning district above the current maximum of 2.9 du/ac to a maximum of 10 du/ac, subject to a special use permit approval. A density equaling 2.9 du/ac or less would continue to be allowed by right. Mr. Robinson reported that Planning Commission voted unanimously at their September 2018 meeting to recommend approval. Chair Sheridan call for discussion; there being none, at 7:11pm, Chair Sheridan open the Public Hearing. There being no one wishing to speak, Chair Sheridan closed the Public Hearing at 7:11pm. Mr. O'Brien gave support to the proposal, noting that this amendment would only impact specific areas of the County and would not impact the rural nature of the County. Mrs. Booker inquired about the length of time it took to get the amendment to the Board; Mrs. Eager indicated that this was a normal process and would like to work on making the process shorter.

With no additional discussion,

MOTION

Mrs. Booker moved that the Board of Supervisors approve ZTA 18:05, An Ordinance to Amend Chapter 22, Article 7 of the Fluvanna County Code by Certain Amendments to Section and Subsection 22-7-8, Thereof, Concerning Permitted Residential Density in the R-3 District. The public purpose of these amendments is to bring density allowances in line with the Comprehensive Plan. Mrs. Eager gave second and the motion passed 5-0. AYE: Sheridan, Booker, Eager, O'Brien, & Weaver. NAY: None. ABSENT: None.

Zoning Text Amendment ZTA 18:06—Brad Robinson, Senior Planner brought forward a request to amend the Fluvanna County Zoning Ordinance to add additional provisions and flexibility for home occupations/home-based businesses. Mr. Robinson noted that currently home-based businesses involve three use classifications: home occupations, small home industries, and fine arts studios. While home occupations are permitted by right in the A-1 District, small home industries and fine arts studios require approval of a special use permit. The primary distinction between a home occupation and a small home industry concerns use of the dwelling versus an accessory building. By definition a home occupation is confined to the dwelling whereas small home industries and fine art studios are typically located in an accessory building. The proposed amendments to the Fluvanna County Zoning Ordinance are intended to provide more flexibility and loosen restrictions for home-based businesses.

The specific amendments include:

- Amend the A-1 District uses permitted by right in Section 22-4-2.1 to include "Studios, fine arts";
- Amend sign regulations in Section 22-15-3 to reduce home occupation signage to four (4) square feet consistently;
- Amend the definition for "Home occupation" in Section 22-22-1;
- Amend the definition for "Studios, fine arts" in Section 22-22-1 to include a provision that any such studio exceeding the requirements of a home occupation shall require approval of a special use permit: and,
- Add Section 22-17-19 to provide associated standards for "Home occupation."

The proposed amendment to the sign regulations in Section 22-15-3 is a result of Planning Commission discussion and request to staff as part of developing the home occupation standards. The proposed standards for home occupations will regulate issues such as size, noise, and product display.

Mr. Robinson reported that the Planning Commission voted unanimously to recommend approval at their September 2018 meeting.

Chair Sheridan opened the Public Hearing at 7:18pm.

- Linda Staiger, Columbia District, spoke in favor of the proposed zoning text amendment and thanked the Planning Commission and the Board for their consideration of this issue.
- Rudy Garcia, Fork Union District, speaking on behalf of the Chamber of Commerce, notes that the Chamber fully supports this proposed amendment.

With no one else wishing to speak, Chair Sheridan, closed the Public Hearing at 7:21pm.

Mrs. Eager pointed out that the new definition of "home occupation" allows home owners to rent rooms in their homes.

MOTION

Mrs. Eager moved that the Board of Supervisors approve ZTA 18:06, an ordinance to amend Chapter 22 of the Fluvanna County code by the amendment of Section 22-4-2.1, regarding uses permitted by right in the A-1 Agricultural District relating to "studios, fine arts"; Section 22-15-3 regarding certain signs in the A-1 Agricultural, the R-1, R-2, R-4 and MHP residential districts, relating to home occupations; Section 22-22-1, Definitions, relating to home occupations and studios, fine arts; and by the addition of a Subsection 22-17-19 providing general standards for home occupations. The public purpose of these amendments is to promote good planning practice and economic development. Mr. Weaver gave

second and the motion passed 5-0. AYE: Sheridan, Booker, Eager, O'Brien, & Weaver. NAY: None. ABSENT: None.

7 - ACTION MATTERS

Fire Hydrant Installation CIP Project – Eric Dahl, DCA/Finance Director

When Louisa County received approval to build the James River Water Project pipeline through the eastern part of Fluvanna County, it was negotiated that Fluvanna County would be able to install fire hydrants along the pipeline, with Fluvanna responsible for the cost.

Referencing the previously agreed upon hydrants, Mr. Dahl noted:

- Fluvanna County will fund Hydrants # 2, 3, 4, 6, 7, 8, 10, 11, 12
- Louisa and Fluvanna will jointly fund (50/50) Hydrant # 1 (located in Louisa County)
- As determined by County Fire Officials, hydrants # 5, 9, 13, 14 are not required.

Staff had previously provided the Board with an estimated cost of \$200,000 to install the fire hydrants along the pipeline route; however, the actual cost to install the fire hydrants is \$142,500. Mr. Dahl noted that having fire hydrants along the eastern part of the County provides an increased safety benefit for Fluvanna County citizens. In order to appropriately reflect the change in cost, the following FY19 budget changes will be made:

- Increase: CIP Fire Hydrant Installation project - \$142,500
- Increase: Use of Unassigned Fund Balance - \$142,500

Following general discussion,

MOTION

Mrs. Eager moved that the Board of Supervisors approve a supplemental appropriation of \$142,500 from Unassigned Fund Balance to the FY19 CIP Budget for the Fire Hydrant Installation project along the James River Water Project pipeline. Mrs. Booker seconded and the motion passed 5-0. AYE: Sheridan, Booker, Eager, O'Brien, & Weaver. NAY: None. ABSENT: None.

Authorization to Advertise for Public Hearing – Piedmont Public Safety Communications System —Steven M. Nichols, County Administrator requested authorization to advertise a Public Hearing for the Piedmont Public Safety Communications System. Mr. Nichols noted that pursuant to Section 15.2-1300 of the Code of Virginia, 1950, as amended, Fluvanna County and Louisa County desire to enter into an Intergovernmental Agreement to establish a Shared Public Safety Radio System referred to as the "Piedmont Public Safety Communications System." Virginia Code requires localities to approve such agreements by ordinance and the County's financing of their system and equipment requires the execution of a Consent to Sublease.

Following general discussion,

MOTION

Mrs. Booker moved the Board of Supervisors authorize staff to advertise for a Public Hearing on November 20, 2018, entitled, "AN ORDINANCE APPROVING THE JOINT INTERGOVERNMENTAL AGREEMENT WITH LOUISA COUNTY FOR THE PIEDMONT PUBLIC SAFETY COMMUNICATIONS SYSTEM." Mr. O'Brien gave second and the motion passed 5-0. AYE: Sheridan, Booker, Eager, O'Brien, & Weaver. NAY: None. ABSENT: None.

Authorization to Advertise for Public Hearing – Zion Crossroads Water/Sewer System Property Acquisition — Steven M. Nichols, County Administrator requested authorization to advertise a Public Hearing for the Zion Crossroads Water/Sewer System Property Acquisition. Pursuant to prior authorizations of the Board, offer letters to the affected property owners are being prepared and sent based on valuations received from Bowman Consulting. A public hearing is required so the County can be prepared to initiate condemnation proceedings quickly, as needed, should negotiations from the offers be unsuccessful. This motion to authorize advertisement of that public hearing, as required by law, prior to adopting a resolution by the Board to (i) initiate condemnation hearings for properties to be taken for public use as part of the Zion Crossroads Water and Sewer System project; (ii) declare its intent to enter and take the properties and interest in properties for a water and sewer system, pipes and lines; (iii) state the compensation and damages, if any, offered to each property owner by the County; and (iv) declare the necessity to enter upon and take such properties and interest in prior to or during the condemnation proceedings. Pursuant to Virginia Code Sec. 15.2-1901(A), the County is authorized to acquire real property and property interests for a public use, and it may do so by exercise of the power of eminent domain. Pursuant to Virginia Code Sec. 15.2-1904, the County may enter upon and take possession of property before the conclusion of condemnation proceedings, using the "quick-take" procedures in Chapter 3 (§ 25.1-300 et seq.) of Title 25.1, for specific public purposes including water supply and sewage disposal systems, pipes and lines, such as the Zion Crossroads Water and Sewer System is that type of public purpose. To proceed under such "quick-take" procedure, pursuant to Virginia Code Section 15.2-1903(B) and 15.2-1905(B), the County may by resolution, after a public hearing, approve the proposed public use and direct the acquisition of the property for the public use by condemnation or other means.

With no discussion,

MOTION

Mr. O'Brien moved the Board of Supervisors authorize staff to advertise for a Public hearing on November 20, 2018, entitled "Public Hearing Pursuant to Virginia Code Sec. 15.2-1901 et seq. to authorize Initiation of Condemnation Proceedings and Use of "Quick Take" Procedures for Acquisition of Property and Interests in Property for the Zion Crossroads Water and Sewer System Project." Mrs. Eager

seconded and the motion passed 5-0. AYE: Sheridan, Booker, Eager, O'Brien, & Weaver. NAY: None. ABSENT: None.

Sheriff's Department Accretion of Duties Pay Increase - Jessica Rice, HR Manager presented a request to approve an accretion of duties pay increase and approval of restructuring the Sheriff's Command Staff. Mr. Nichols noted that while two distinct actions are requested, Mrs. Rice will present all information for this request and the *Restructuring of Sheriff's Department Command Staff* request.

Mrs. Rice reported that:

- Following the vacancy of a Lieutenant Deputy position in May 2018, the Sheriff's Department has restructured the staff to downgrade one Lieutenant of Patrol position to a Sergeant of Courts position.
- Lieutenant Peterson's current salary is a marginal 2.5% above the Sergeants under his command. The Lieutenant of Courts' salary (a lateral position) is 12.75% above Lt. Peterson's current salary.
- Lieutenant Peterson has absorbed job duties that were previously assigned to the 2nd Lieutenant of Patrol, and is now the sole Lieutenant in command of the Division.
- Lt. Peterson's salary increase will be covered by savings realized through the downgraded vacant Lieutenant position.

Should the requested changes be implemented, salary implications would be:

- FY19 Salary savings= \$16,052.37, FY20 and beyond Salary Savings= \$12,452.37.
- Lt. Peterson salary= \$53,964.33; 10% increase= \$5,396.43.
- After increase, remaining salary savings of approximately \$7,000 per year.

With respect to the restructuring request, Mrs. Rice reported that:

- The Sheriff's Department has conducted a staffing assessment and determined that the organization operates more efficiently with one Lieutenant of Operations position, rather than 2.
- One Lieutenant position is currently vacant (since May 29, 2018). The Sheriff's Department is requesting to change the open Lieutenant position to a new Sergeant of Courts position which will be filled through an internal promotion. No additional FTEs are requested.
- Due to increased workload in the Judicial Affairs Division, Courthouse operations require daily oversight, scheduling, and liaison with court staff. There are five full-time and two volunteer deputies assigned to courthouse operations. Successful daily courthouse operations require a single point of contact and supervisor to interact with the judges, court clerks, jails, and staff as well as to schedule transportation of prisoners. Promoting one of the current courthouse staff positions to a Sergeant position would provide the needed oversight and ensure greater continuity of operations with funding to come from funds previously allocated to the Lieutenant position.

With no discussion,

MOTION

Mrs. Booker moved to approve a 10% pay increase for Lt. Sean Peterson, Fluvanna County Sheriff's Office, effective October 28, 2018, with such funds to come from Fluvanna County Sheriff's Department FY19 Personnel Budget savings. Mrs. Eager offered second and the motion passed 5-0. AYE: Sheridan, Booker, Eager, O'Brien, & Weaver. NAY: None. ABSENT: None.

Restructuring of Sheriff's Department Command Staff - Jessica Rice, HR Manager

With no discussion,

MOTION

Mrs. Booker moved to approve the restructuring of the Sheriff's Department command staff to include the downgrade one Lieutenant (Operations) position to the new position number 6573 - Sergeant of Courts. Mrs. Eager offered second and the motion passed 5-0. AYE: Sheridan, Booker, Eager, O'Brien, & Weaver. NAY: None. ABSENT: None.

General Professional Engineering & Architectural Services Term Contract- Draper Aden Associates—Cyndi Toler, Purchasing Officer brought forward a request to approve two term contracts. Mrs. Toler indicated that there are four individual term contracts, for as-needed services, to be considered for approval, two of which were presented here. Though there are two requests, one presentation encompassing both requests was given. Mrs. Toler noted that the contracts are for one year, with the option of four, one-year renewals.

Background information on the RFP process:

- An RFP was issued in July 2018 for Professional Engineering & Architectural Services, as needed. Services may include civil engineering and design, management and review; architectural design, management and review; evaluation and design of water and sewer facilities (including rehabilitation options); design of improvements to wastewater pumping and water booster pump stations and well facilities (including water storage tanks); water and sewer system modeling; professional services associated with design and operation of solid waste facilities; regulatory issues and coordination with regulatory agencies; site plan engineering and surveying related to site grading, environmental engineering, storm water drainage, traffic impact analysis, road design, erosion and sediment control measures and storm water management facilities; geotechnical services; construction administration; grants administration, and inspection services associated with capital improvement projects; and other related similar services.
- Ten proposals were received
- Six firms were chosen for consideration; four of those were chosen to enter into term contracts with;

- Term contracts are used by County Staff on an as needed basis to provide County with professional engineering & architectural services. The firms selected provide a wide range of disciplines to sufficiently meet the County’s needs. All project agreements are approved by the board prior to any work being done.
- FY19 Budget Project agreement costs:
 - TASK 1 GW sampling event 2018 S2 \$7,274 lump sum
 - TASK 2 2018 Annual Groundwater Report \$3,942 lump sum
 - TASK 3 GW sampling event 2019 S1 \$8,308 lump sum
 - TASK 4 Gas Monitoring (Oct, 18 to Jun, 19) \$1,583 lump sum
 - TASK 5 Post-Closure Insp. (Oct, 18 Jun, 19) \$813 lump sum
 - Total not-to exceed expenditure under this proposal = \$21,920

With no discussion,

MOTION

Mr. O’Brien moved the Board of Supervisors approve the General Professional Engineering & Architectural Services Term Contract with Draper Aden Associates, and authorize the County Administrator to execute the Agreement, subject to approval as to form by the County Attorney. Mr. Weaver gave second and the motion passed 5-0. AYE: Sheridan, Booker, Eager, O’Brien, & Weaver.

And,

Mr. O’Brien moved the Board of Supervisors to approve Project Agreement #1 between Fluvanna County and Draper Aden Associates to continue the Environmental Monitoring Programs of the Fluvanna County closed Landfill totaling \$21,920, and further authorize the County Administrator to execute the agreements subject to approval as to form by the County Attorney. On a second by Mrs. Booker, the motion passed 5-0. AYE: Sheridan, Booker, Eager, O’Brien, & Weaver. NAY: None. ABSENT: None.

General Professional Engineering & Architectural Services Term Contract- Crabtree, Rohrbaugh & Associates— Cyndi Toler, Purchasing Officer

With no discussion,

MOTION

Mr. O’Brien moved the Board of Supervisors approve the General Professional Engineering & Architectural Services Term Contract with Crabtree, Rohrbaugh & Associates, and authorize the County Administrator to execute the Agreement, subject to approval as to form by the County Attorney. Mrs. Eager gave second and the motion passed 5-0. AYE: Sheridan, Booker, Eager, O’Brien, & Weaver. NAY: None. ABSENT: None.

7A – BOARDS AND COMMISSIONS

Board, Commission, and Committee Appointments – Steven M. Nichols, County Administrator presented that slate of candidates for the stated Boards and Commissions.

With no discussion,

MOTION

Mrs. Booker moved the Board of Supervisors approve the following Board, Commission, or Committee appointment(s) with terms as stated by staff:

Board/Commission/Committee	Appointees	Begins Term	Ends Term
Fluvanna Partnership for Aging – At-large	Pam Bevins	Immediately	Dec 31, 2021
Palmyra Area Revitalization Committee (PARC)	Debby Deal	Immediately	Jun 30, 2020
Parks and Recreation Advisory Board – Youth Representative	Madeline Fulk	Oct 1, 2018	Sep 30,2021

With a second by Mr. O’Brien, the motion passed 5-0. AYE: Sheridan, Booker, Eager, O’Brien, & Weaver. NAY: None. ABSENT: None.

8 – PRESENTATIONS

Louisa Regional Business Park—Andy Wade, Louisa County Economic Development Director came before the Board with a proposal for a Regional Business Park located in the southeastern region of Louisa County.

Mr. Wade highlighted the following priorities for moving forward with the proposed business park:

- Premier site in the Commonwealth - Large land users - 50-100 acres per project
- Tier 5/4 minimum
- Develop the project responsibly
- Maintain rural character- surrounding property
- Clean industries
- Re-direct the regions out-commuting workforce

Mr. Wade noted that as a regional business park, anticipated revenue would be shared among the participating localities.

Fluvanna Partnership for Aging Update – Curtis Putnam, FPA Chair provided the Board with an update on the current membership, mission, and goals of the Fluvanna Partnership for Aging. Mr. Putnam highlighted partnerships with community agencies and activities undertaken in the past year by the Partnership for Aging, including participation at Fluvanna TRIAD and a review of Partnership by-laws.

Zion Crossroads Water and Sewer System Construction Bid Update—Cyndi Toler, Purchasing Officer gave a brief overview and update on the Zion Crossroads Water and Sewer System.

Procurement History:

- March 2015 - Preliminary Engineering Report (PER) presented to BOS by RK&K
- June 2015 - RFP for selection of an design engineering firm
- September 2015 - Dewberry Engineers Inc. selected to design
- November 2015 - Dewberry design work begins
- December 2015 - Bowman Consulting Group begins area surveys
- December 2016 - Town Hall Meetings held to inform public of the project
- November 2017 - BOS approved final design, Authorized IFB and property acquisition
- February 2018 - Contracted with Bowman Consulting for Property Appraisal Services
- June 2018 - Contracted with Charlottesville Settlement Co. to begin Title Search Services for easement and property acquisition
- May 2018 - IFB’s issued for Construction
- October 2018 - Bid Opening on October 9
 - Bids Received:
 - 2018-03 Water and Sewer System- 6 Bids
 - 2018-04 Elevated Water Tank- 4 Bids
 - 2018-05 Water Booster Station and Wastewater Pump Station- 6 Bids
- Final Bids
 - Working estimate for construction - \$9,851,000
 - Low Bids - \$8,884,673
 - Savings Estimate - \$966,326

FLUVANNA COUNTY - ZION CROSSROADS WATER AND SEWER SYSTEM PROJECT			
Vendor	2018-03 Water and Sewer System	2018-04 Elevated Water Tank	2018-05 WBPS and WWPS
	Lump Sum Price	Lump Sum Price	Lump Sum Price
AG Dillard	\$ 4,993,673.38	\$ -	\$ -
SJ Louis Construction	\$ 8,440,620.00	\$ -	\$ -
Walter C. Via Enterprises	\$ 6,854,633.00	\$ -	\$ -
Faulconer Construction	\$ 7,499,386.00	\$ -	\$ -
Fielders Choice Enterprise	\$ 6,316,619.50	\$ -	\$ 2,640,954.00
English Construction Company	\$ 6,534,694.00	\$ -	\$ 2,394,500.00
Caldwell Tanks	\$ -	\$ 2,237,000.00	\$ -
Landmark Structures	\$ -	\$ 2,086,000.00	\$ -
Phoenix Fabricators	\$ -	\$ 1,994,024.00	\$ -
CBI (Chicago Bridge & Iron)	\$ -	\$ 1,991,000.00	\$ -
MEB General Contractors	\$ -	\$ -	\$ 1,997,000.00
FL Showalter	\$ -	\$ -	\$ 2,083,000.00
Sargent Corporation	\$ -	\$ -	\$ 1,900,000.00
Crowder Construction	\$ -	\$ -	\$ 2,359,800.00
TOTAL FOR ALL 3 PROJECT COMPONENTS	\$8,884,673.38		

Bid to Estimate Comparison

CONSTRUCTION CATEGORY	Estimated Construction Cost	Final Low Bid	Bidder	Bid to Estimate Difference
Water Main (DOC east to 250/15)	\$2,567,000			
Water Main (DOC west to Memory Lane)	\$549,000			
Wastewater Force Main	\$2,965,000			
Water & Wastewater Main Subtotal	\$6,081,000	\$4,993,673	AG Dillard	(\$1,087,327)
Elevated Water Storage Tank	\$2,239,400			
Elevated Water Storage Tank Subtotal	\$2,239,400	\$1,991,000	CBI	(\$248,400)
Water Booster Station	\$642,600			
Wastewater Pump Station	\$888,000			
Water Booster & Wastewater Pump Station Subtotal	\$1,530,600	\$1,900,000	Sargent Corp.	\$369,400
Water & Wastewater Construction Grand Total	\$9,851,000	\$8,884,673	\$ -	(\$966,327)

Financing Timeline

- May 2017 - VRA Summer Pool Application Submitted (\$8.5 Million)
 - June-July 2017 - County's Loan Request Approved by VRA; \$8.5M with NTE rate of 4.25% for 20 years; Public Hearing for VRA financing
 - August 2017 - Final pricing received from VRA; Loan officially closed
- Virginia Resource Authority Final Numbers
 - All-in True Interest Cost: 3.012%
 - Par Amount: \$7,715,000
 - Total Proceeds w/Premium: \$8,612,579 (~\$8.5 avail.)
 - Avg. Annual Debt Service: ~\$561,000 (20 Yrs)
- Interest Payment Only in FY18 – CASH
- Full Debt Service Payment in FY19 and Beyond – BUDGETED

Zion Crossroads Water & Sewer System Project Budget Updated: October 17, 2018	Water System Total Costs	Sewer System Total Costs	Water System West Extension Total Costs	TOTAL PROJECT COSTS
DESIGN				
Preliminary Engineering Report (PER)	\$ 27,600	\$ 18,400		\$ 46,000
PER Validation	\$ 13,530	\$ 9,020		\$ 22,550
Geotechnical Engineering	\$ 31,745	\$ 19,920	\$ 5,150	\$ 56,815
Bidding Services	\$ 11,592	\$ 7,728		\$ 19,320
Permitting	\$ 17,826	\$ 11,884	\$ 8,300	\$ 38,010
Design	\$ 242,473	\$ 152,402	\$ 37,880	\$ 432,755
Aerial Surveying	\$ 20,736	\$ 13,824		\$ 34,560
Ground Surveying	\$ 65,878	\$ 39,552	\$ 22,950	\$ 128,380
Real Estate Acquisition Services (est.)	\$ 30,000	\$ 20,000	\$ 5,000	\$ 55,000
Land / Right of Way Acquisition (est.)	\$ 90,000	\$ 60,000	\$ 15,000	\$ 165,000
Wetland Mitigation Credits (est.)	\$ 2,400	\$ 1,600	\$ 500	\$ 4,500
Legal (est.)	\$ 66,000	\$ 44,000	\$ 10,000	\$ 120,000
Local Costs of Issuance	\$ 21,000	\$ 14,000		\$ 35,000
Design Subtotal	\$ 640,780	\$ 412,330	\$ 104,780	\$ 1,157,890
CONSTRUCTION PHASE SERVICES				
Construction Administration	\$ 156,894	\$ 104,596	\$ 19,215	\$ 280,705
Construction Inspection	\$ 224,640	\$ 149,760	\$ 19,215	\$ 393,615
Construction Phase Services Subtotal	\$ 381,534	\$ 254,356	\$ 38,430	\$ 674,320
CONSTRUCTION				
Elevated Water Storage Tank	\$ 1,991,000			\$ 1,991,000
Water Booster Station	\$ 797,687			\$ 797,687
Water Main	\$ 2,108,002		\$ 450,835	\$ 2,558,837
Wastewater Pump Station		\$ 1,102,313		\$ 1,102,313
Wastewater Force Main		\$ 2,434,837		\$ 2,434,837
Water & Wastewater Construction Subtotal	\$ 4,896,689	\$ 3,537,149	\$ 450,835	\$ 8,884,673
CONSTRUCTION CONTINGENCY				
Construction Contingency (10%) + OH/Profit (15%)	\$ 503,438	\$ 335,625	\$ 74,282	\$ 913,344
Construction Contingency Subtotal	\$ 503,438	\$ 335,625	\$ 74,282	\$ 913,344
TOTALS	\$ 6,422,441	\$ 4,539,461	\$ 668,327	\$ 11,630,228
			Existing Cash Funded	\$ (778,390)
			Remaining Funds Needed	\$ 10,851,838
			Debt Proceeds - Funds Available	\$ (8,505,053)
			County Cash Funding Requirement	\$ 2,346,785

Next Steps for Procurement

- Bids being reviewed for details and completeness
- Contracts must be executed within 120 days of the bid opening (by Feb 6, 2019)
- Anticipate final contracts on BOS agenda for approval at November 20, 2018, meeting.
- Property Acquisition - ongoing
 - 87 - affected parcels along project route
 - 3 - Fee Simple properties
 - 83 - Easements only (two in Louisa)
 - 1 - Department of Corrections

9 - CONSENT AGENDA

The following items were approved under the Consent Agenda for October 17, 2018:

Minutes of October 3, 2018—Kelly Belanger Harris, Clerk to the Board

Accounts Payable Report, September 2018—Eric Dahl, Deputy County Administrator/Finance Director

Products and Services Agreement with CenturyLink Sales Solutions, Inc—Cyndi Toler, Purchasing Officer

CRMF Request - FSPCA Renovations & Repairs—Wayne Stephens, Director of Public Works/County Engineer

CRMF Request - Palmyra Rescue Squad—Wayne Stephens, Director of Public Works/County Engineer

Proclaiming October Domestic Violence Prevention Month—Kelly Belanger Harris, Clerk to the Board

MOTION

Mr. Weaver moved to approved the consent agenda, for the October 17, 2018 Board of Supervisors meeting, and to ratify Accounts Payable and Payroll for September 2018, in the amount of \$2,697,294.13. Mrs. Booker seconded and the motion passed 5-0. AYE: Sheridan, Booker, Eager, O'Brien, & Weaver. NAY: None. ABSENT: None.

10 - UNFINISHED BUSINESS

Elected Officials Breakfast – Mrs. Booker suggested providing issue papers to those in attendance. Mr. Nichols noted that idea has already been added to the planning for next year’s Breakfast.

11 - NEW BUSINESS

Tax Credit for citizens implementing solar energy solutions. – Mr. O’Brien requesting offering a small tax credit for citizens implementing solar energy solutions. Staff was directed to assess the impact on property tax revenue.

12 - PUBLIC COMMENTS #2

At 8:45pm Chair Sheridan opened the second round of Public Comments. With no one else wishing to speak, Chair Sheridan closed the second round of Public Comments at 8:45pm.

13 - CLOSED MEETING

MOTION TO ENTER INTO A CLOSED MEETING

At 8:45pm, Mr. O’Brien moved the Fluvanna County Board of Supervisors enter into a closed meeting, pursuant to the provisions of Section 2.2-3711 A.1, A.3, A.6, A.7, & A.8 of the Code of Virginia, 1950, as amended, for the purpose of discussing Personnel, Real Estate, Investment of Funds, Litigation, and Legal Matters. Mrs. Booker seconded. The motion carried, with a vote of 5-0. AYE: Sheridan, Booker, Eager, O’Brien, and Weaver. NAY: None. ABSENT: None.

MOTION TO EXIT A CLOSED MEETING & RECONVENE IN OPEN SESSION

At 11:23pm, Mr. O’Brien moved that the Closed Meeting be adjourned and the Fluvanna County Board of Supervisors convene again in open session and “BE IT RESOLVED, the Board of Supervisors does hereby certify to the best of each member’s knowledge (i) only public business matters lawfully exempted from open meeting requirements under Section 2.2-3711-A of the Code of Virginia, 1950, as amended, and (ii) only such public business matters as were identified in the motion by which the closed meeting was convened were heard, discussed, or considered in the meeting.” Mr. Weaver seconded. The motion carried, with a roll call vote, of 5-0. AYES: Sheridan, Booker, Eager, O’Brien, and Weaver. NAYS: None. ABSENT: None.

MOTION TO EXTEND

Mrs. Booker moved to extend the meeting until midnight. On a second by Mr. O’Brien, the motion passed 5-0. AYE: Sheridan, Booker, Eager, O’Brien, & Weaver. NAY: None. ABSENT: None.

14 - ADJOURN

MOTION:

At 11:24pm Mrs. Booker moved to adjourn the regular meeting of Wednesday, October 17, 2018. Mr. O’Brien seconded and the motion carried with a vote of 5-0. AYES: Sheridan, Booker, Eager, O’Brien, & Weaver. NAYS: None. ABSENT: None.

ATTEST:

FLUVANNA COUNTY BOARD OF SUPERVISORS

Kelly Belanger Harris
Clerk to the Board

John M. Sheridan
Chair

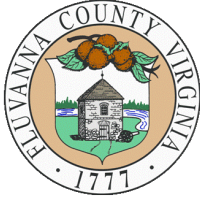

BOARD OF SUPERVISORS

County of Fluvanna
Palmyra, Virginia

PROCLAMATION 05-2018

PROCLAIMING OCTOBER DOMESTIC VIOLENCE AWARENESS MONTH

WHEREAS, the problems of domestic violence are not confined to any group or groups of people but cross all economic, racial and societal barriers, and are supported by societal indifference; and

WHEREAS, the crime of domestic violence violates an individual's privacy, dignity, security, and humanity, due to systematic use of physical, emotional, sexual, psychological and economic control and/or abuse, with the impact of this crime being wide-ranging; and

WHEREAS, no one person, organization, agency or community can eliminate domestic violence on their own—we must work together to educate our entire population about what can be done to prevent such violence, support victims/survivors and their families, and increase support for agencies providing services to those community members; and

WHEREAS, the Shelter for Help in Emergency has led the way in the County of Fluvanna in addressing domestic violence by providing 24-hour hotline services to victims/survivors and their families, offering support and information, and empowering survivors to chart their own course for healing; and

WHEREAS, the Shelter for Help in Emergency commemorates its 39th year of providing unparalleled services to women, children and men who have been victimized by domestic violence;

NOW THEREFORE, BE IT RESOLVED, in recognition of the important work being done by the Shelter for Help in Emergency, that I, John M. Sheridan, Chair of Fluvanna County Board of Supervisors, do hereby proclaim the month of October 2018 as DOMESTIC VIOLENCE AWARENESS MONTH, and urge all citizens to actively participate in the scheduled activities and programs sponsored by the Shelter for Help in Emergency, and to work toward the elimination of personal and institutional violence against women, children and men.

Signed and sealed this 17 day of October, 2018.

John M. Sheridan

Chair, Board of Supervisors

**FLUVANNA COUNTY BOARD OF SUPERVISORS
AGENDA ITEM STAFF REPORT**

TAB A

MEETING DATE:	Nov 20, 2018				
AGENDA TITLE:	Adoption of the Fluvanna County Board of Supervisors Nov 7, 2018 Meeting Minutes.				
MOTION(s):	I move the meeting minutes of the Fluvanna County Board of Supervisors Regular Meeting on Wednesday, Nov 7, 2018, be adopted.				
STRATEGIC INITIATIVE?	Yes	No	If yes, list initiative(s):		
		X			
AGENDA CATEGORY:	Public Hearing	Action Matter	Presentation	Consent Agenda	Other
				XX	
STAFF CONTACT(S):	Kelly Belanger Harris, Clerk to the Board				
PRESENTER(S):	Steven M. Nichols, County Administrator				
RECOMMENDATION:	Approve				
TIMING:	Routine				
DISCUSSION:	None.				
FISCAL IMPACT:	N/A				
POLICY IMPACT:	N/A				
LEGISLATIVE HISTORY:	None				
ENCLOSURES:	Draft Minutes for Nov 7, 2018				
REVIEWS COMPLETED:	Legal	Finance	Purchasing	HR	Other

**FLUVANNA COUNTY BOARD OF SUPERVISORS
REGULAR MEETING MINUTES
Circuit Court Room
November 7, 2018
Regular Meeting 4:00pm**

MEMBERS PRESENT: John M. (Mike) Sheridan, Columbia District, Chair
Mozell Booker, Fork Union District, Vice Chair
Patricia Eager, Palmyra District
Donald W. Weaver, Cunningham District

ABSENT: Tony O'Brien, Rivanna District

ALSO PRESENT: Steven M. Nichols, County Administrator
Fred Payne, County Attorney
Kelly Belanger Harris, Clerk for the Board of Supervisors

1 - CALL TO ORDER, PLEDGE OF ALLEGIANCE, & MOMENT OF SILENCE

At 4:01pm Chair Sheridan, called to order the Regular Meeting of November 7, 2018. After the recitation of the Pledge of Allegiance, a moment of silence was observed.

3 - ADOPTION OF AGENDA

MOTION

Mrs. Booker moved to accept the Agenda, for the November 7, 2018 Regular Meeting of the Board of Supervisors. Mr. Weaver seconded and the Agenda was adopted by a vote of 4-0. AYES: Sheridan, Booker, Eager, and Weaver. NAYS: None. ABSENT: O'Brien.

4 - COUNTY ADMINISTRATOR'S REPORT

Mr. Nichols reported on the following topics:

- Halloween with Parks and Recreation
 - Sat, Oct 20 -- Second Teen Night at the Lake Monticello Clubhouse.
 - Fri, Oct 26 -- Annual Magic Show and Movie at the Fluvanna Library.
 - Sat, Oct 27 -- Annual Halloween Festival at Pleasant Grove Park.
 - Special thanks to LMOA, Fluvanna Library staff and FUMA Interact Club for assisting us during our various events!
- Community and County Staff Recognitions
 - Trunk or Treat in Palmyra - Organized by Clerk of the Circuit Court and her staff
- Announcements and Updates
 - Updated grant application submitted to request funding (\$887K) - 96 Self-Contained Breathing Apparatus (SCBA); Fit testing equipment; 4 associated cascade systems
 - Plan to issue a new Invitation for Bids for construction of a Class A Burn Building (with potential for Class B retrofit) - Request for change from Class B to Class A sent to Virginia Department of Fire Programs
 - "A Report of Findings and Recommendations: County of Fluvanna Fire & EMS Study". First two recommendations in 2012 were:
 - Unified Coordination – The County should employ a Chief of Fire-Rescue for the supervision and coordination of fire and rescue. The Fire-Rescue Association's purpose should be expanded to include administrative and operational oversight in conjunction with the Chief of Fire-Rescue.
 - Fire Prevention Activities – The County should enact the Statewide Fire Prevention Code through a local ordinance. Additionally, the County should enforce the Statewide Fire Prevention Code; potential methods of enforcement are included herein.
 - Plan to begin the process of hiring a Fire and Rescue Chief for county-wide operational oversight - The Board directed staff to begin the process of hiring a Fire and Rescue Chief for county-wide operational oversight.
 - Plan to begin the review process for potential adoption of the Statewide Fire Prevention Code - The Board directed staff to begin the review process for potential adoption of the Statewide Fire Prevention Code.
- Columbia and CARE Task Force Update
 - Staff met with:
 - Piedmont Housing Alliance (Nov 1) - Housing issues discussion
 - Health Department (Nov 5) - Sewage and Housing issues discussion
 - Scheduling additional meetings with:
 - Thomas Jefferson Soil and Water Conservation District, Fluvanna/Louisa Housing Foundation, VDOT

- Planning, Zoning, and Code Enforcement - Working on a number of potential violation notices to go to property owners
- Update from the Central Virginia Regional Jail Authority (of which we have a 20% ownership stake)
 - Supervisor Don Weaver is one of Fluvanna’s representatives on the Authority. To best utilize taxpayer dollars, Mr. Weaver recently presented a motion to begin earning interest off Authority funds. As a result, the Jail Board will be depositing \$3,000,000 into a CD for 6 months, and the resulting 2.07% interest rate will earn the Authority more than \$30,000 toward next year’s budget.
- Upcoming Meetings

Day	Date	Time	Purpose	Location
TUE	Nov 20	7:00 PM	BOS Regular Meeting	Courtroom
Wed	Dec 5	4:00 PM 7:00 PM	BOS Regular Meeting Work Session – FY20 FCPS and County Preliminary Budget Discussion	Courtroom
Wed	Dec 19	4:00 PM 7:00 PM	Budget Work Session – Non-Profit Briefs BOS Regular Meeting	Courtroom

5 - PUBLIC COMMENTS #1

At 4:15pm Chair Sheridan opened the first round of Public Comments.

Holly Foster, 246 The Cross Rd, addressed the Board with concerns regarding her property. With no one else wishing to speak, Chair Sheridan closed the first round of Public Comments at 4:26pm.

6 - PUBLIC HEARING

None.

7 - ACTION MATTERS

TJPDC Regional Legislative Program – David Blount, TJPDC Legislative Liaison presented the Draft 2019 Legislative Program to the Board.

Priorities included:

- State Budget and Funding Obligations
- Public Education Funding
- Broadband
- Local Revenue Authority
- Children Service’s Act
- Land Use and Growth Management

MOTION

Mrs. Eager moved to adopt the Draft Thomas Jefferson Planning District Legislative Program for 2019. Mr. Weaver gave second and the motion passed 4-0. AYE: Sheridan, Booker, Eager, & Weaver. NAY: None. ABSENT: O’Brien.

Heritage Trail Land Donation – Aaron Spitzer, Parks & Recreation Director requested acceptance of the Fluvanna Heritage Trail. The Heritage Trail Foundation, Inc., approached the County to inform it that the Foundation was disbanding. Upon discussion, the Foundation proposed donating the Fluvanna Heritage Trail to the County at no cost to the County. Mr. Spitzer reports that that there will be minimal cost for upkeep and maintenance.

With no discussion,

MOTION

Mrs. Booker moved to accept the deed and donation of 0.543 acres, more or less, identified on the tax maps of the County of Fluvanna, as parcel 30-A-119B, and commonly known as the Fluvanna Heritage Trail from Fluvanna Heritage Trail, Inc., subject to satisfactory update of title and approval of the form of all documents by the County Attorney. I further move to authorize the County Administrator to execute the deed to evidence such acceptance, and to execute any other documents he deems necessary or appropriate in connection with the donation, containing such terms as may be approved by the County Administrator, on behalf of the County of Fluvanna. Mrs. Eager gave second and the motion passed 4-0. AYE: Sheridan, Booker, Eager, & Weaver. NAY: None. ABSENT: O’Brien.

Professional AE Services Term Contract- Dewberry—Cyndi Toler, Purchasing Officer brought forward the third of four requests to approve term contracts for as-needed professional services. The first two requests were approved at the October 17, 2018 Board of Supervisors meeting.

As a recap, Mrs. Toler noted:

- An RFP was issued July 2018 for Professional Engineering & Architectural Services as needed. Services may include civil engineering and design, management and review; architectural design, management and review; evaluation and design of water and sewer facilities (including rehabilitation options); design of improvements to wastewater pumping and water booster pump stations and well facilities (including water storage tanks); water and sewer system modeling; professional services associated with design and operation of solid waste facilities; regulatory issues and coordination with regulatory agencies; site plan engineering and surveying related to site grading, environmental engineering, storm water drainage, traffic impact analysis, road design, erosion and sediment control measures and storm water

management facilities; geotechnical services; construction administration; grants administration, and inspection services associated with capital improvement projects; and other related similar services.

- Ten proposals were received. The committee chose 6 firms to meet with
- Four of those firms have been chosen to have term contracts with the county.
- Dewberry Engineers Inc. has worked well for staff on the Zion Crossroads design project.
- Term contracts will be used by County Staff on an as-needed basis to provide County with professional engineering & architectural services. The firms selected provide a wide range of disciplines to sufficiently meet the County’s needs.
- All project agreements will be approved by the board prior to any work being done.
- Costs will be based on rates sheets included by each firm as well as # of hours expected to complete task order.

With no discussion,

MOTION

Mrs. Booker moved the Board of Supervisors approve the General Professional Engineering & Architectural Services Term Contract with Dewberry Engineers Inc., and authorize the County Administrator to execute the Agreement, subject to approval as to form by the County Attorney. Mr. Weaver gave second and the motion passed 4-0. AYE: Sheridan, Booker, Eager, & Weaver. NAY: None. ABSENT: O’Brien.

Professional AE Services Term Contract- RKK—Cyndi Toler, Purchasing Officer brought forward the fourth of four requests to approve term contracts for as-needed professional services.

With no discussion,

MOTION

Mrs. Eager moved the Board of Supervisors approve the General Professional Engineering & Architectural Services Term Contract with Rummel, Klepper & Kahl, LLP, and authorize the County Administrator to execute the Agreement, subject to approval as to form by the County Attorney. Mrs. Booker gave second and the motion passed 4-0. AYE: Sheridan, Booker, Eager, & Weaver. NAY: None. ABSENT: O’Brien.

Radiological Emergency Preparedness Program (REPP) Grant—Debbie Smith, Emergency Management Coordinator, requested ratification of the Radiological Emergency Preparedness Program (REPP) Grant. Ms. Smith reported that Fluvanna County is within the 50 mile inundation area of Dominion/North Anna Nuclear Power Plant. These grant funds will help in establishing, maintaining, and operating such emergency plans, programs and capabilities to deal with nuclear accidents as are required by the Nuclear Regulatory Commission and the Federal Emergency Management Agency with respect to nuclear power stations. Grant award for Fluvanna County could be \$700 with no county match required. Once funds are awarded, they roll over up to 5 years at a maximum of \$3,500; if these funds are not used, they must be returned to the Virginia Department of Emergency Management. Ms. Smith noted that the County has already received \$3500 of grant funds from prior year carry amounts.

MOTION

Mrs. Booker moved the Board of Supervisors ratify the application for the FY19 REPP in the amount of \$700 for supporting local emergency management preparedness. Mrs. Eager gave second and the motion passed 4-0. AYE: Sheridan, Booker, Eager, & Weaver. NAY: None. ABSENT: O’Brien.

And,

Mrs. Booker further moved the Board of Supervisors approve a supplemental appropriation of \$4,200 to the VDEM REPP Budget in FY19, with funding to come from this state grant award and prior year carry over amounts. Mrs. Eager gave second and the motion passed 4-0. AYE: Sheridan, Booker, Eager, & Weaver. NAY: None. ABSENT: O’Brien.

7A – BOARDS AND COMMISSIONS

MOTION

Mrs. Booker moved and Mr. Weaver seconded, that the Board of Supervisors approve the following Board, Commission, or Committee appointment(s):

Board, Commission, Committee	Appointee	Term Begin	Term End
Board of Equalization	Everett Hannah	01/01/2019	12/31/2019
Board of Equalization	Tom Payne	01/01/2019	12/31/2019
Board of Equalization	Gloria Vest	01/01/2019	12/31/2019
Board of Equalization	Dan Nunziato	01/01/2019	12/31/2019
Board of Equalization	April Ward	01/01/2019	12/31/2019
TJPDC Regional Housing Partnership	Gequetta Murray-Key	Immediately	11/06/2019

AYE: Sheridan, Booker, Eager, & Weaver. NAY: None. ABSENT: O’Brien.

8 – PRESENTATIONS

VDOT Quarterly Report—Alan Saunders, PE, VDOT Louisa Residency provided an update of activities in Fluvanna County.

Highlights included:

- County Safety and Operational Improvements:
 - Route 250 at Route 631 (Troy Rd): VDOT crews plan to remove trees and perform minor grading to improve sight distance - Scheduled for late November
 - Route 629/631 Intersection Review - Developing Right of Entry Agreement to be able to enter the property to cut trees and slope the bank.
 - Village of Palmyra Traffic Circle: County and VDOT staff plan to simulate EMS response prior to installing pavement markings;
 - Route 53 at Route 619 (Cunningham): VDOT continues to evaluate this intersection for interim and long-term safety improvements
- Traffic Engineering Studies under Review:
 - Route 250 speed study, from Route 631 to Route 15.
 - Route 53 shoulder safety improvements (proximity 4800 block +/-) Corridor study ongoing
 - Route 629/631 intersection review

Chair Sheridan inquired about the feasibility of VDOT receiving help from local fire departments to clear roads that are subject to frequent flooding. Mr. Saunders indicated that this is a help and will follow up with additional information.

Mrs. Eager relayed a concern from a constituent regarding the speed limit on Union Mills Road. Mr. Saunders indicated that an engineering speed study could be conducted; Mrs. Eager indicated that she would forward the address after the meeting.

Mrs. Booker reported on stop signs that are regularly knocked down and inquired about the feasibility of placing these signs differently. Mr. Saunders indicated that a study of the location would be undertaken.

CSA Update—Bryan Moeller, CSA Coordinator provided a semi-annual update about CSA services and activities in the County.

Mr. Moeller reviewed:

- Review of Purchases of Services from the Children’s Services Act during FY18
 - FY18 Spending (Final) - FY18 CSA Purchase of Services (POS)
 - Adopted Budget: \$3,100,000
 - Actual: \$2,912,453
 - Difference: \$187,547
 - FY18 POS vs FY17 POS
 - FY17 Actual: \$3,186,408
 - FY18 Actual: \$2,912,453
 - Difference: \$273,955
- Summary of demographics during FY18
- Summary of long-term strategy

9 - CONSENT AGENDA

The following items were approved under the Consent Agenda for November 7, 2018:

Minutes of October 10, 2018, Local Elected Officials Breakfast—Kelly Belanger Harris, Clerk to the Board
Municode Services Contract – Cyndi Toler, Purchasing Officer
Position Description Revision – PW Director (3690) – Jessica Rice, HR Manager
FEMA FY18 Assistance to Firefighters Grant—Eric Pollitt, Management Analyst
CRMF – Bus Motor—Eric Pollitt, Management Analyst

MOTION

Mr. Weaver moved to approved the consent agenda, for the November 7, 2018 Board of Supervisors meeting. Mrs. Booker seconded and the motion passed 4-0. AYE: Sheridan, Booker, Eager, & Weaver. NAY: None. ABSENT: O’Brien.

10 - UNFINISHED BUSINESS

Mr. Sheridan asked for a status update of the Fluvanna Christian Service Society’s move at the Carysbrook complex. Mr. Nichols indicated he is attending the FCSS Board Meeting on Thursday, November 8, 2018, and hopes to resolve any final concerns at that time so the agreements can be executed.

11 - NEW BUSINESS

None.

12 - PUBLIC COMMENTS #2

At 5:45pm Chair Sheridan opened the second round of Public Comments.

With no one wishing to speak, Chair Sheridan closed the second round of Public Comments at 5:45pm.

MOTION TO RECESS

At 5:46pm, Mrs. Booker moved to recess. On a second by Mr. Weaver, the motion passed 4-0. AYE: Sheridan, Booker, Eager, & Weaver. NAY: None. ABSENT: O'Brien.

13 - WORK SESSION

At 6:13pm the meeting was reconvened.

The Work Session items for discussion were:

1. Utility Standards Manual
 - For developers and others to connect to or expand our system
 - Includes physical connection requirements
 - Includes computing required capacity (meter size)
2. System Rules and Regulations
 - Who can connect
 - Who must connect
 - When/conditions required for connection
3. Rate, Fees, and Charges
 - Connection Fees for Water and Sewer
 - Water and sewer usage rates
4. Policies and Procedures
 - Billing schedules
 - Leak adjustments, late charges, returned checks, etc.
 - Rental versus owner policies
5. Projected ZXR Growth Rates
 - Needed for modelling capital cost recoupment and supporting rate cases

14 - CLOSED MEETING**MOTION TO ENTER INTO A CLOSED MEETING**

At 7:50pm, Mr. Weaver moved the Fluvanna County Board of Supervisors enter into a closed meeting, pursuant to the provisions of Section 2.2-3711 A.1, A.6, A.7, & A.8 of the Code of Virginia, 1950, as amended, for the purpose of discussing Personnel, Investment of Funds, Litigation and Legal Matters. Mrs. Booker seconded. The motion carried, with a vote of 4-0. AYE: Sheridan, Booker, Eager, & Weaver. NAY: None. ABSENT: O'Brien.

MOTION TO EXIT A CLOSED MEETING & RECONVENE IN OPEN SESSION

At 8:49pm, Mr. Weaver moved that the Closed Meeting be adjourned and the Fluvanna County Board of Supervisors convene again in open session and "BE IT RESOLVED, the Board of Supervisors does hereby certify to the best of each member's knowledge (i) only public business matters lawfully exempted from open meeting requirements under Section 2.2-3711-A of the Code of Virginia, 1950, as amended, and (ii) only such public business matters as were identified in the motion by which the closed meeting was convened were heard, discussed, or considered in the meeting." Mrs. Booker seconded. The motion carried, with a roll call vote, of 4-0. AYES: Sheridan, Booker, Eager, & Weaver. NAYS: None. ABSENT: O'Brien.

MOTION TO EXTEND

At 8:49 pm, Mr. Weaver moved to extend the meeting until midnight. On a second from Mrs. Eager, the motion passed 4-0. AYE: Sheridan, Booker, Eager, & Weaver. NAY: None. ABSENT: O'Brien.

15 - ADJOURN**MOTION:**

At 8:50pm Mrs. Eager moved to adjourn the regular meeting of Wednesday, November 7, 2018. Mrs. Booker seconded and the motion carried with a vote of 4-0. AYES: Sheridan, Booker, Eager, & Weaver. NAYS: None. ABSENT: O'Brien.

ATTEST:

FLUVANNA COUNTY BOARD OF SUPERVISORS

Kelly Belanger Harris
Clerk to the Board

John M. Sheridan
Chair

FLUVANNA COUNTY BOARD OF SUPERVISORS
AGENDA ITEM STAFF REPORT

TAB B

MEETING DATE:	November 20, 2018				
AGENDA TITLE:	Revision to Policy 2.19 - Travel and Business Expenses				
MOTION(s):	I move to approve the revisions to Policy 2.19 – Travel and Business Expenses, and the associated travel and business expenses forms, as presented.				
STRATEGIC INITIATIVE?	Yes	No	If yes, list initiative(s):		
		X			
AGENDA CATEGORY:	Public Hearing	Action Matter	Presentation	Consent Agenda	Other
		XX			
STAFF CONTACT(S):	Steve Nichols, County Administrator				
PRESENTER(S):	Steve Nichols, County Administrator				
RECOMMENDATION:	Approval				
TIMING:	Current				
DISCUSSION:	<p>The Board adopted the new “Section 2.19 - Travel and Business Expenses” policy and associated new forms for Pre-Travel Authorization, Travel and Expense Claim, and Statement in Lieu of Receipts, on September 19, 2019.</p> <p>Following adoption, a number of additional circumstances were identified, and the handling of which was not clearly delineated in the new policy.</p> <p>Revisions include:</p> <p><u>Policy 2.19 – Travel and Business Expenses</u></p> <ul style="list-style-type: none"> • Added new and updated Day Travel (50 miles or more) and Local Travel (less than 50 miles) definitions. • Clarified requirement for travel expense receipts. • Specified that fuel charges are not reimbursable when using POV since mileage reimbursement is intended to cover fuel costs, wear and tear, private insurance costs, etc. • Clarified partial M&IE per diem reimbursement for Day Travel. • Added Local Travel discussion and clarified that partial M&IE per diem is generally not reimbursable for Local Travel. <p><u>Form 2.19 – Travel and Business Expenses</u></p> <p>Key Issues Guidance</p> <ul style="list-style-type: none"> • Defined “Day Travel” of 50 miles or more one-way from the work station. • Defined “Local Travel” of less than 50 miles one-way from the work station. 				

	<p>Form 2.19A – Travel and Business Expense Pre-Authorization Request</p> <ul style="list-style-type: none"> Revised form to more clearly identify expected expenses and requests for Travel Advance payments. Added blocks to specify Overnight, Day, or Local Travel category. <p>Form 2.19B – Travel and Business Expense Reimbursement Claim</p> <ul style="list-style-type: none"> Added blocks to specify Overnight, Day, or Local Travel category. <p>Sample Travel Claims</p> <ul style="list-style-type: none"> Created revised samples using the updated forms. 				
FISCAL IMPACT:	N/A				
POLICY IMPACT:	N/A				
LEGISLATIVE HISTORY:	N/A				
ENCLOSURES:	Policy 2.19-Travel and Business Expenses REVISED (Redline) Form 2.19-Travel and Business Expenses UPDATED				
REVIEWS COMPLETED:	Legal	Finance	Purchasing	HR	Other
				X	

02. PERSONNEL

2.19. Travel and Business Expenses

BOS Approved – September 19, 2018

Revision BOS Approved – November 7, 2018 (*Pending*)

This policy is effective for travel and expenses incurred on or after October 1, 2018.

The Federal GSA Per Diem Rates are available online for determining per diem costs for travel, travel day adjustments, and correct rates for the time of year (<https://www.gsa.gov/travel/plan-book/per-diem-rates>).

2.19.1. Policy. To provide employees and other authorized travelers with fair and equitable compensation for expenses related to the conduct of official County business.

2.19.2. Definitions. All words in this section shall have their ordinary and usual meanings except those defined in this section which shall have the meaning set forth below:

A. “Approving Official” means the County Administrator or designee for County departments and offices; the Constitutional Officer for the respective constitutional offices; the Agency Head or designee for various County agencies; or the chair of the Board of Supervisors for the Board.

B. “Authorized Traveler” means the person authorized by an approving official to travel on behalf of Fluvanna County, to accrue certain expenses, and to be reimbursed for such authorized expenses as are applicable under this section. Authorized travelers may include:

1. Employees and other persons who may be periodically approved to travel on behalf of the County (e.g., persons appointed by the Board of Supervisors to serve on boards and commissions or serving the county in other capacities without compensation).

2. Candidates for specialized skill positions not readily available in the county job market may be considered an authorized traveler for up to two interview trips for a given position during any twelve month period to travel to the county from their place of residence outside the county.

C. "Day Travel" means travel of 50 miles or more (one-way) from the work station that does not include an overnight stay.

DC. "Employee" means any person employed in a full time or part time non-exempt position, an exempt position, a temporary/provisional position as defined in Policy 2.4, and all county elected officials.

ED. "Federal lodging limit" means the maximum amount an authorized traveler may be reimbursed per day for lodging expenses, excluding applicable taxes, in the respective host city for travel within the continental United States as published in the Code of Federal Regulations, 41 CFR Sec. 301, App. A, and as hereafter amended.

FE. "Full Day" in the context of this section is a travel departure before 7:00 a.m. and travel return after 6:00 p.m.

GF. "Government Rates" means the discounted rates offered to government employees, in the course of conducting official business, by lodging establishments, rental car agencies and other providers of services to government employees.

HG. "Local Travel" means travel of less than 50 miles (one-way) from the work station outside the county that does not include an overnight stay.

IH. "Maximum Rates" for lodging costs, excluding taxes, and meals and incidental expenses are prescribed under Code of Federal Regulations, 41 CFR Sec. 301, App. A, and as hereafter amended, for reimbursement of per diem expenses incurred during official travel within the continental United States.

IJ. "Meals and Incidental Expenses (M&IE) Per Diem" means the per day amount that an authorized traveler may be reimbursed for such expenses in a host city within the continental United States as published in the Code of Federal Regulations, 41 CFR Sec. 301, App. A, and as hereafter amended.

- Includes all meal costs with taxes and tips.
- Incidental rates are calculated to allow for expenses such as fees and tips to baggage carriers, concierges, hotel staff and laundry.
- Per diem rates are daily rates – there is no roll-over of per diem from one day to the next.
- Per diem is payable to a traveler without itemized meal or incidental expense receipts.

KJ. "Official County Business" means business that relates directly to a person's work function and that is beneficial to the county.

LK. "Overnight travel" means travel outside of the county that exceeds twelve hours and includes an overnight stay.

ML. "Partial M&IE Per Diem" means the allocation of M&IE rates to be used in making deductions from the M&IE allowance as published in the Code of Federal Regulations, 41 CFR Sec. 301, App. B, and as hereafter amended, when less than a full day of travel is involved.

NM. "Per Diem Expenses" means the amount that an authorized traveler may be reimbursed per day for lodging expenses, excluding applicable taxes, and M&IE in the respective host city for travel within the continental United States as published in the Code of Federal Regulations, 41 CFR Sec. 301, App. A, and as hereafter amended.

ON. "Pre-Paid Expenses" means any expense paid by the County before the completion of training/travel (e.g., registration fees paid on a County credit card).

PO. “Privately Owned Vehicle (POV)” means a vehicle owned by an authorized traveler and approved for use on official County business and subject to mileage reimbursement.

QP. “Work Station” is the job location at which an employee spends the majority of his or her working hours.

2.19.3. Responsibilities

- A. Approving officials authorize travel for members of their respective departments.
- B. The County Administrator may authorize travel advances on a case by case basis.
- C. The Director of Finance or his designee reviews and validates all travel claims and causes funds to be issued as a reimbursement. The Director establishes internal procedures to assure proper accounting and control of travel advances and reimbursement payments.
- D. The authorized traveler is responsible for the proper expenditure of funds, for obtaining appropriate itemized receipts, for recording and reporting of expenses associated with the travel, and for following the procedures contained in this policy.
- E. Failure to adhere to this policy may result in disciplinary action.
- F. Exceptions to this policy require the County Administrator’s approval prior to any related travel expenditure obligation.
- G. The Finance Department shall post on the county website links to the federal lodging limits, meal and incidental rates, and M&IE allocation deductions, as published in the Code of Federal Regulations, 41 CFR Sec. 301, App. A and App. B, as rate changes occur.
- H. A copy of this policy shall be posted on the County’s website. Department/Agency Heads are responsible for ensuring travelers from their departments are informed of the travel and reimbursement rules in this policy.

2.19.4. Pre-Authorization

- A. Authorization for day, local, or overnight travel, training, or other business expenses shall be obtained on an approved County pre-authorization form prior to commencing the activity and per the provisions of this section.
- B. The approving official shall ensure that the traveler is provided information about the applicable travel expense reimbursement policies prior to incurring travel expenses.
- C. If expenses are incurred without prior authorization, the approving official or designee will determine whether an emergency existed and the expenses are reimbursable. The person requesting reimbursement will be responsible for payment of expenses that were incurred without prior authorization and subsequently determined not to constitute an emergency.

D. Travel for non-mandatory attendance at job-related seminars, conferences, conventions or training may be authorized with reimbursement at less than the rates otherwise authorized, provided that the reduced reimbursement rates are mutually agreed to in writing by the approving official and the traveler prior to the travel.

2.19.5. General Rules

A. Itemized receipts are required for ALL County credit card transactions.

B. Itemized receipts are also required for other reimbursable expenses not charged on a County credit card, with the exception of meals and incidental expenses covered by a daily per diem rate and ~~mileage for authorized use of a~~ privately owned vehicle mileage when use is authorized for official travel.

CB. Travelers shall not claim per diem for anyone other than themselves and reimbursements will be made only to the authorized traveler seeking the reimbursement and not to a second party.

DC. Per diem and other reimbursable expenses must appear on the travel claim each day and not summarized by trip, week, or other increment.

ED. Authorized travelers are expected to exercise the same care in incurring expenses that he or she would exercise if traveling on personal business and using personal funds.

FE. The traveler shall be responsible for excess costs and additional travel expenses resulting from taking an indirect route or delaying the return trip for personal preference or convenience, except that additional travel expenses may be approved and reimbursed if an indirect route or delay reduces the county's total costs.

GF. Reimbursement for travel outside the continental United States shall be based upon actual expenses to a maximum of the overseas rates established by the federal General Services Administration for federal travel to the specific location, subject to all other provisions of this section.

HG. The county shall not fund travel expenses when a source of reimbursement other than the county is specified in county, state, or federal law or policy. Approving officials may authorize payment of the difference between what the county policy allows for the total travel activity and the total reimbursed from any other source for expenses reimbursable under the provisions of this section, but shall not selectively reimburse for only specific items with differing reimbursement rates differing between the county and any other source.

2.19.6. Transportation Costs. The county will pay actual and necessary costs of transportation for conducting official county business as follows:

A. Travel shall be by the method of transportation and route that will be most advantageous to the county, considering the cost of transportation, other travel expenses and salary. The excess cost of first class or business class fare for a given mode of travel shall not be reimbursed when less expensive fares are available.

B. Items receipts are required for transportation costs (except POV mileage).

C. Government rates must always be requested when a commercial method of travel is authorized.

D. When a private mode of transportation is used in lieu of a more customary form of transportation to the event site, travel expenses shall be reimbursed at the lesser of the two costs.

E. County Vehicles. May be used for any authorized travel when available. The requesting party must obey all laws of the jurisdiction in which the vehicle is being operated. The vehicle will be used in conducting County business only.

F. Privately Owned Vehicles (POV). Generally, using a personal vehicle is considered cost beneficial to the County for occasional travel. A traveler may use his or her personal vehicle for travel and be reimbursed at the Federal mileage rate when authorized by the approving official. Reimbursable mileage is not to exceed the actual mileage traveled.

1. The starting and ending locations of travel are the traveler's official work station or the residence, depending on the work schedule and the work status of the traveler at the time of departure and arrival.

2. Transportation between a person's home and regularly assigned work station is not reimbursable.

3. Fuel charges are not reimbursable when using POV since mileage reimbursement is intended to cover fuel costs, wear and tear, private insurance costs, etc.

2.19.7. Lodging Costs. Lodging costs are reimbursable at the limits established by the federal travel regulations for the host city, published annually in the Code of Federal Regulations, 41 CFR Sec. 301, App. A.

A. Lodging costs will be reimbursed only for approved overnight travel.

1. Itemized lodging receipts are required.

2. Government rates must always be requested.

3. Lodging costs in the host city may be claimed from the night before the authorized event starts through the night before it ends, unless reasonably priced and timely return transportation is not available, thereby necessitating additional lodging costs.

B. The traveler shall be reimbursed for actual lodging costs incurred for single occupancy, to a maximum of the federal lodging limit for the host city plus taxes.

1. If the lodging receipt indicates a charge for double occupancy and two persons are authorized to travel on behalf of the county, each traveler shall be allowed one-half the double occupancy charge.

2. If one person is not authorized to travel on behalf of the county (e.g., a spouse of an employee), the person authorized to travel shall be reimbursed at the single occupancy rate to a maximum of the federal lodging limit.

C. For seminars, conferences, or conventions, costs for lodging at the event site may be authorized in excess of the federal lodging limit for the host city under one or more of the following conditions:

1. No alternate lodging is available within a reasonable distance of the event site which is within the federal lodging limit for the host city. The traveler must provide a signed statement of unavailability with the request for reimbursement;

2. The authorized means of transportation between the alternate lodging site and the event site would exceed the savings in lodging costs; or

3. The approving official, or his or her designee, has authorized the excess expenditure in writing and in advance for any exigent circumstances that might exist.

2.19.8. Meal and Incidental Expense (M&IE) Rates

A. Overnight Travel

1. Meal and incidental expenses are reimbursable at the M&IE per diem rates established by the federal travel regulations for the host city, published annually in the Code of Federal Regulations, 41 CFR Sec. 301, App. A.

2. M&IE rates are determined based on the location of lodging as follows:

- Departure day: Where you spend the night.
- Return day: Where you spent the night before returning home.

3. M&IE per diem is reimbursed at 75% for departure and return days.

B. ~~Local~~Day Travel

1. For travel less than a full day and 50 miles or more (one-way) from the work station, the traveler may receive partial M&IE per diem if travelling or away from their work station at the following times: 7:00 a.m. (breakfast), 12 noon (lunch), and/or 6:00 p.m. (dinner).

2. The per diem expense allowance will be reduced and allocated as shown in the Code of Federal Regulations, 41 CFR Sec. 301, App. B.

C. Local Travel. For travel less than a full day and less than 50 miles (one-way) from the work station, travelers are generally not authorized any M&IE per diem. Policy exceptions may be approved by the County Administrator on a case-by-case basis when circumstances warrant.

DC. Other Non-Travel Circumstances. Meal expenses incurred while a person is not in a day, local, or overnight travel status are not normally reimbursable, except that meals or refreshments may be reimbursed or paid directly by the county for official county business purposes as follows:

1. When approved, reimbursable meals incurred while in non-travel status are limited to the fixed meal allowance established by the federal travel regulations for each participant.

2. For staff retreats lasting more than four hours in a single day, for either single or multiple days, not to exceed one retreat per quarter per county division, agency, or constitutional office;

3. When an integral part of a job-related seminar, conference, convention or training occurs during the meal, and when approved by the approving official or designee.

ED. Higher Rate Exceptions. Meal expenses may be incurred at a rate higher than that established by federal regulations when one or more of the following conditions apply:

1. The approving official or designee approves the cost of the meal because a circumstance related to a particular meal results in exceeding the authorized meal rate. A receipt detailing the expense, accompanied by written justification, shall be submitted with the request to exceed the fixed meal allowance;

2. The meal expense is incurred on behalf of another agency that reimburses the county for the expense, in which case the expense shall be reimbursed according to the rules specified by the funding agency; or

3. When necessitated by special dietary needs.

2.19.9. Miscellaneous Reimbursable Expenses. Itemized receipts are required for approved miscellaneous expenses related to official county business that are considered essential. Such expenses include, but are not limited to:

A. Registration fee of a seminar, conference, convention or similarly organized program.

B. Parking; ferry and bridge tolls; taxi, subway and bus fares; and airport shuttle service.

C. Baggage handling service, when necessitated by physical limitations or when carrying excessive baggage or equipment required for an official business purpose, may be claimed beyond the expense limitations 2.19.8 above.

D. Rental of a room in a hotel or other facility that is used to transact official business.

E. Telephone calls or facsimile (fax) transmissions necessary for the conduct of official business or to advise of a change in official travel plans.

2.19.10. Non-Reimbursable Personal Expenses. Miscellaneous travel expenses not directly related to the conduct of official county business are not reimbursable. Certain expenses are considered personal in nature and non-reimbursable including, but not limited to:

A. Laundry, except as covered by the incidental per diem rate provided for in section 2.19.8.

B. Personal telephone calls, except as provided for in section 2.19.9.

C. Entertainment, clothing, personal sundries and services, transportation to places of entertainment and similar personal items.

D. Room service costs that exceed the fixed rate established for the meal incurred, except when necessitated by physical limitations.

E. Valet services, except when necessitated by physical limitations.

F. Personal "trip insurance" and medical or hospital services.

G. Alcoholic beverages.

H. Tobacco products.

I. Tips and gratuities, except as provided for in section 2.19.8.

J. Fines and penalties.

K. Dependent care.

2.19.11. Travel Advances

A. Cash travel advances to cover authorized expenses may be authorized by the County Administrator when deemed necessary and appropriate for the traveler's circumstances. In addition, a travel advance:

1. Is generally not allowed for those who have been issued a County credit card.

2. Request shall be submitted to the Finance Department within normal accounts payable deadlines and via the respective department/agency head and the County Administrator.

3. Shall not be issued for less than \$25 and shall not exceed the amount of anticipated reimbursable expenses.

B. Travelers must submit their itemized travel expense claim accompanied by the unexpended portion of such advance, if any, as outlined in subsection 2.19.13.

C. The Finance Department shall withhold from the employee's next paycheck any travel expense advance, or any portion thereof, not properly accounted for or repaid to the Finance Department within claim submission period.

D. County employees who are delinquent in accounting for or repaying a prior travel expense advance shall be ineligible for any additional advances until such time as repayment or acceptable justification for the delinquent advance has been made.

2.19.12. Leave of Absence During Travel

A. When leave of absence of any kind is taken while in a travel status, the exact hour of departure and return to duty status shall be shown on the travel expense claim. Except as provided in the following paragraph, expense reimbursement, including transportation to and from the post of duty, shall not be granted for such period.

B. Whenever a traveler takes leave of absence because of incapacitation due to illness or injury not due to the employee's own misconduct, the authorized reimbursement for lodging and subsistence may be continued during the leave period, but not to exceed in total the authorized cost for return to the employee's official station or residence, whichever is closer, and then back to the assignment.

2.19.13. Overnight Travel Expense Reimbursement Claim

A. The traveler shall submit a fully itemized travel expense claim with required receipts to their approving official within 10 days of the travel return date to obtain reimbursement for travel expenses reimbursable under the provisions of this section.

1. Travel expense reimbursement claims shall include the times, dates, places, business purpose, and expenses on approved County forms.

2. Any applicable conference, convention, or seminar brochure; airline itinerary; travel authorization(s) and justifications for exceeding the established limits for travel expenses shall be attached to the travel expense reimbursement claim.

3. Reimbursement claims shall clearly identify any pre-paid expenses on the claim form to ensure that the traveler is not reimbursed for such expenses.

B. The approving official shall review, sign, and forward the travel claim to the Finance Department.

C. The Finance Director may reject any reimbursement claim not completed per current policy or that are submitted more than 30 days after the completion of travel.

2.19.14. ~~Day~~ Local Travel and Training Expense Reimbursement Claim

A. The traveler shall submit a fully itemized expense claim with required receipts to their respective approving authority within 10 days of the travel/training completion date (except as allowed in subparagraph 4 below) to obtain reimbursement for reimbursable ~~local~~ day travel and training expenses.

1. Travel expense reimbursement claims shall include the times, dates, places, business purpose, and expenses on approved County forms.

2. Any applicable conference, convention, or seminar brochure, authorization(s), and justifications for exceeding the established limits for such expenses shall be attached to the expense reimbursement claim.

3. Reimbursement claims shall clearly identify any pre-paid expenses on the claim form to ensure that the traveler is not reimbursed for such expenses.

4. Authorized travelers may consolidate multiple reimbursement requests into one form when such action is deemed to be more efficient than submitting multiple single requests for processing (e.g., board or commission members who attend assigned meetings on a periodic or recurring basis). In such cases, claims will be submitted at least semi-annually.

B. The approving official shall review, sign, and forward the travel claim to the Finance Department.

C. The Finance Director may reject any reimbursement claim not completed per current policy or that are submitted more than 30 days after the completion of travel/training.

2.19.15. Local Travel and Training Expense Reimbursement Claim

A. The traveler shall submit a fully itemized expense claim with required receipts to their respective approving authority within 10 days of the travel/training completion date (except as allowed in subparagraph 4 below) to obtain reimbursement for reimbursable local travel and training expenses.

1. Travel expense reimbursement claims shall include the times, dates, places, business purpose, and expenses on approved County forms.

2. Any applicable conference, convention, or seminar brochure, authorization(s), and justifications for exceeding the established limits for such expenses shall be attached to the expense reimbursement claim.

3. Reimbursement claims shall clearly identify any pre-paid expenses on the claim form to ensure that the traveler is not reimbursed for such expenses.

4. Authorized travelers may consolidate multiple reimbursement requests into one form when such action is deemed to be more efficient than submitting multiple single requests for processing (e.g., board or commission members who attend assigned meetings on a periodic or recurring basis). In such cases, claims will be submitted at least semi-annually.

B. The approving official shall review, sign, and forward the travel claim to the Finance Department.

C. The Finance Director may reject any reimbursement claim not completed per current policy or that are submitted more than 30 days after the completion of travel/training.

2.19.165. Other Expense Reimbursement Claims

A. The authorized traveler shall submit a fully itemized expense claim with required receipts to their respective approving official within 10 days of an authorized expense to obtain reimbursement for such expenses.

1. The expense reimbursement claim shall include the times, dates, places, business purpose, and expenses on approved County forms.

2. Any applicable conference, convention, or seminar brochure, authorization(s), and justifications for exceeding the established limits for such expenses shall be attached to the expense reimbursement claim.

3. Reimbursement claims shall clearly identify any pre-paid expenses on the claim form to ensure that the traveler is not reimbursed for such expenses.

B. The approving official shall review, sign, and forward the travel claim to the Finance Department.

C. The Finance Director may reject any reimbursement claim not completed per current policy or that are submitted more than 30 days after the incurred expenses.

2.19.176. Repayment of Unauthorized Reimbursements. The Finance Department shall seek repayment of expenses from the person who was reimbursed whenever an audit or subsequent review of travel expense reimbursements finds that such expenses were reimbursed contrary to the provisions of this section.



Travel & Business Expense Guidance

Applicable for travel and expenses on or after October 1, 2018

To understand the important travel rules and requirements	Key Tips for Travel and Business Expenses
This file has three primary Travel and Expense form tabs:	Form 2.19A - Travel and Business Expense Pre-Authorization Request (Rev)
	Form 2.19B - Travel and Business Expense Reimbursement Claim
	Form 2.19C - Travel and Business Expense Statement in Lieu of Receipts
And three sample completed claim tabs:	Sample Travel Claim #1 (Overnight Travel)
	Sample Travel Claim #2 (Overnight Travel)
	Sample Travel Claim #3 (Local Travel)
For additional information about travel, business expenses, and reimbursement claim policies and procedures, refer to:	<p>-- Personnel Policies, Section 2.19 – Travel and Business Expenses</p> <p>https://www.fluvannacounty.org/policyprocedure/page/02-personnel-policies-and-forms</p>
	<p>-- Contact the Finance Department at (434) 591-1910 for assistance.</p>
<p>The Federal GSA Per Diem Rates are available online for determining per diem costs for travel, travel day adjustments, and correct rates for the time of year.</p>	<p>https://www.gsa.gov/travel/plan-book/per-diem-rates</p>

KEY TIPS FOR TRAVEL AND BUSINESS EXPENSES

Fluvanna County, Virginia

ITEM	DISCUSSION
Pre-Authorization	Authorization required for local or overnight travel, training, or other business expenses obtained <u>prior to commencing the activity</u> .
Care in Incurring Expenses	Authorized travelers are expected to exercise the same care in incurring expenses that he or she would exercise if traveling on personal business and using personal funds.
Local Travel	Travel of less than 50 miles (one-way) from the work station that does not include an overnight stay.
Day Travel	Travel of 50 miles or more (one-way) from the work station that does not include an overnight stay.
Overnight Travel	Travel outside of the county that exceeds twelve hours and includes an overnight stay.
Full Day	Travel departure before 7:00 a.m. and travel return after 6:00 p.m.
Meals and Incidental Expenses (M&IE) Per Diem	<p>Per day amount a traveler may be reimbursed for such expenses in a host city.</p> <ul style="list-style-type: none"> - Includes all meal costs with taxes and tips, and incidental expenses such as laundry and fees and tips to baggage carriers, concierges, hotel staff, etc. - Per diem rates are daily rates (no roll-over of per diem from day to day). - M&IE per diem is payable without itemized meal or incidental expense receipts. - M&IE rates are determined based on the location of lodging as follows: <ul style="list-style-type: none"> -- Departure day: Where you spend the night. -- Return day: Where you spent the night before returning home. - M&IE per diem is reimbursed at 75% for departure and return days. - For travel less than a full day and 50 miles or more from the work station, the traveler may receive partial M&IE per diem if travelling or away from their work station at the following times: 7:00 am (breakfast), 12 noon (lunch), and/or 6:00 pm (dinner).
Pre-Paid Expenses	Any expense paid by the County before or during the completion of training/travel (e.g., registration fees paid on a County credit card, lodging charged on a county card, etc.). Such expenses must be identified on the travel claim.
Itemized Receipts	Are required for reimbursable expenses (except meals and incidental expenses covered by a daily per diem rate or mileage for authorized use of a privately owned vehicle for official travel).
Per Diem and Other Expenses	Must appear on the travel claim each day and not summarized by trip, week, or other increment.
Non-Reimbursable Expenses	Laundry; personal telephone calls; entertainment, clothing, personal sundries and services, transportation to places of entertainment, and similar personal items; room service costs that exceed the fixed rate established for the meal incurred, except when necessitated by physical limitations; valet services, except when necessitated by physical limitations; personal "trip insurance" and medical or hospital services; alcoholic beverages; tobacco products; tips and gratuities; fines and penalties; dependent care.
Travel Advances	Cash advances may be authorized by the County Administrator when deemed to cover authorized expenses necessary and appropriate for the traveler's circumstances.
Travel and Other Expense Reimbursement Claims	Traveler shall submit a fully itemized travel expense claim with required receipts within 10 days of the travel return date.

The Federal GSA Per Diem Rates are available online for determining per diem costs for travel, travel day adjustments, and correct rates for the time of year (<https://www.gsa.gov/travel/plan-book/per-diem-rates>).

For questions or clarifications, please contact the Finance Department at (434) 591-1910.

Travel and Business Expense Pre-Authorization Request	Form 2.19A
Refer to Fluvanna County Policy "2.19 - Travel and Business Expenses" for specific rules and requirements.	Ver. 10-18 Rev

Requestor's Name	Department	Date of Request

Travel / Expense Purpose <i>(Attach Training/Conference Brochure or other explanatory information)</i>	Travel Category (check one)
	<input type="checkbox"/> Overnight Travel
	<input type="checkbox"/> Day Travel (50+ miles one way)
	<input type="checkbox"/> Local Travel (within 50 miles)

TRAVEL DAY	1	2	3	4	5	6	7	
Date								
Departing From								
Arriving At								

CATEGORY	PLANNED EXPENSES							TOTAL
POV Mileage								\$ -
Airfare or Rail								\$ -
Car Rental								\$ -
Taxi/Bus								\$ -
Parking & Tolls								\$ -
Lodging								\$ -
M&IE Per Diem								\$ -
Conf./Registration Fee								\$ -
								\$ -
								\$ -
								\$ -
Mileage rate per mile effective Jan 1, 2018	\$0.545	TOTAL EXPECTED COST						\$ -

Notes and/or Travel Advance Justification <i>(When Travel Advance requested, submit form to Finance after Approving Official signature.)</i>	ADVANCE REQUESTED
	\$ -

I have reviewed and agreed to comply with the County's Travel and Business Expenses policy and procedures.	I recommend approval of the travel and business expenses for the purpose listed.	I hereby authorize the travel and business expenses for the purpose listed.
Requestor Signature and Date	Supervisor / Dept Head Signature and Date	Approving Official Signature and Date

Reimbursement Category	Org #	Object #	Total

Travel and Business Expense Reimbursement Claim

Page 1 of:

Form 2.19B

Refer to Fluvanna County Policy "2.19 - Travel and Business Expenses" for specific rules and requirements.

Ver. 10-18 Rev

Claimant's Name					Claimant's Home Address			Department	
Travel / Expense Purpose <i>(Attach Training/Conference Brochure or other explanatory information)</i>						Travel Category (check one)			
						Overnight Travel			
						Day Travel (50+ miles one way)			
						Local Travel (within 50 miles)			
TRAVEL DAY	1	2	3	4	5	6	7		
Date									
Departure Time									
Departed From									
Arrival Time									
Arrived At									
CATEGORY	ACTUAL EXPENSES <i>(Receipts required, except for M&IE)</i>							TOTAL	
POV Mileage								\$ -	
Airfare or Rail								\$ -	
Car Rental								\$ -	
Taxi/Bus								\$ -	
Parking & Tolls								\$ -	
Lodging								\$ -	
M&IE Per Diem								\$ -	
Conf./Registration Fee								\$ -	
								\$ -	
								\$ -	
								\$ -	
Mileage rate per mile effective Jan 1, 2018	\$0.545	Normal commuting mileage to / from home is not reimbursable.				Less Travel Advance Rcvd		\$ -	
							Less County Prepaid Expenses		\$ -
							TOTAL REIMBURSEMENT REQUEST		\$ -
I certify this claim is true to the best of my knowledge, that no part of the amounts claimed have been paid (unless otherwise noted), and that all expenditures claimed were made in the discharge of official duties.			I have reviewed this travel claim.			I approve submission of this travel claim to Finance for final review and processing.			
Claimant Signature and Date			Supervisor / Dept Head Signature and Date			Approving Official Signature and Date			
Reimbursement Category		Org #		Object #		Total			

Travel and Business Expense Statement in Lieu of Receipts

Form 2.19C

Refer to Fluvanna County Policy "2.19 - Travel and Business Expenses" for specific rules and requirements.

Ver. 10-18

Claimant's Name		Department	Travel / Expense Purpose
Date(s)	Expense Details	Amount Claimed	
I certify by this statement that receipts for the above travel and business expenses were misplaced, lost, or destroyed. I furnish this statement in lieu of the proper receipt(s) required to process my claim.		I have reviewed this Statement in Lieu of Receipts.	I approve submission of this Statement to Finance for final review and processing.
Claimant Signature and Date		Supervisor / Dept Head Signature and Date	Approving Official Signature and Date
Finance Department Review and Action			

Travel and Business Expense Reimbursement Claim

Refer to Fluvanna County Policy "2.19 - Travel and Business Expenses" for specific rules and requirements.

Ver. 10-18 Rev

Claimant's Name	Claimant's Home Address	Department
Jane R. Traveler	132 Main Street, Palmyra, VA 22963	Administration

Travel / Expense Purpose <i>(Attach Training/Conference Brochure or other explanatory information)</i>	Travel Category (check one)
VACo Municipal Clerk's Conference in Virginia Beach, VA	<input checked="" type="checkbox"/> Overnight Travel
	<input type="checkbox"/> Day Travel (50+ miles one way)
	<input type="checkbox"/> Local Travel (within 50 miles)

TRAVEL DAY	1	2	3	4	5	6	7	
Date	5-Aug-18	6-Aug-18	7-Aug-18	8-Aug-18				
Departure Time	2:00 PM			11:00 AM				
Departed From	Home			Virginia Beach				
Arrival Time	5:00 PM			4:00 PM				
Arrived At	Virginia Beach			Home				

Sample #1

CATEGORY	ACTUAL EXPENSES <i>(Receipts required, except for M&IE)</i>							TOTAL
POV Mileage	170			170				\$ 185.30
Airfare or Rail								\$ -
Car Rental								\$ -
Taxi/Bus								\$ -
Parking & Tolls	\$ 10.00	\$ 10.00	\$ 10.00					\$ 30.00
Lodging	\$ 137.00	\$ 137.00	\$ 137.00					\$ 411.00
M&IE Per Diem	\$ 44.25	\$ 59.00	\$ 59.00	\$ 44.25				\$ 206.50
Conf./Registration Fee	\$ 225.00							\$ 225.00
								\$ -
								\$ -
								\$ -

Mileage rate per mile effective Jan 1, 2018	\$0.545	Normal commuting mileage to / from home is not reimbursable.	Less Travel Advance Rcvd	\$ 200.00
Lodging and Conference Fee paid in advance with my County credit card.			Less County Prepaid Expenses	\$ 636.00
TRAVEL ADVANCE of \$200.00 received prior to travel.			TOTAL REIMBURSEMENT REQUEST	\$ 221.80

I certify this claim is true to the best of my knowledge, that no part of the amounts claimed have been paid (unless otherwise noted), and that all expenditures claimed were made in the discharge of official duties.	I have reviewed this travel claim.	I approve submission of this travel claim to Finance for final review and processing.
Claimant Signature and Date	Supervisor / Dept Head Signature and Date	Approving Official Signature and Date

Reimbursement Category	Org #	Object #	Total

Travel and Business Expense Reimbursement Claim						Page 1 of:	1	Form 2.19B
Refer to Fluvanna County Policy "2.19 - Travel and Business Expenses" for specific rules and requirements.						Ver. 10-18 Rev		
Claimant's Name			Claimant's Home Address			Department		
John G. Goetter			132 Main Street, Palmyra, VA 22963			Finance		
Travel / Expense Purpose <i>(Attach Training/Conference Brochure or other explanatory information)</i>						Travel Category (check one)		
2017 VACo Conference in Hot Springs, VA						XX	Overnight Travel	
							Day Travel (50+ miles one way)	
							Local Travel (within 50 miles)	
TRAVEL DAY	1	2	3	4	5	6	7	
Date	12-Nov-17	13-Nov-17	14-Nov-17					
Departure Time	9:00 AM		11:00 AM					
Departed From	Home		Hot Springs VA					
Arrival Time	11:00 AM		1:00 PM					
Arrived At	Hot Springs VA		Office					
CATEGORY	ACTUAL EXPENSES <i>(Receipts required, except for M&IE)</i>							TOTAL
POV Mileage	108		108					\$ 117.72
Airfare or Rail								\$ -
Car Rental								\$ -
Taxi/Bus								\$ -
Parking & Tolls								\$ -
Lodging	\$ 290.22	\$ 290.22						\$ 580.44
M&IE Per Diem								\$ -
Conf./Registration Fee	\$ 225.00							\$ 225.00
								\$ -
								\$ -
								\$ -
<i>Mileage rate per mile effective Jan 1, 2018</i>	\$0.545	Normal commuting mileage to / from home is not reimbursable.				Less Travel Advance Rcvd		\$ -
Lodging and Conference Fee paid with my County credit card. Meals included in room rate.						Less County Prepaid Expenses		\$ 805.44
						TOTAL REIMBURSEMENT REQUEST		\$ 117.72
I certify this claim is true to the best of my knowledge, that no part of the amounts claimed have been paid (unless otherwise noted), and that all expenditures claimed were made in the discharge of official duties.			I have reviewed this travel claim.			I approve submission of this travel claim to Finance for final review and processing.		
Claimant Signature and Date			Supervisor / Dept Head Signature and Date			Approving Official Signature and Date		
Reimbursement Category			Org #		Object #		Total	

Sample #2

Travel and Business Expense Reimbursement Claim Page 1 of: **1** Form 2.19B

Refer to Fluvanna County Policy "2.19 - Travel and Business Expenses" for specific rules and requirements.

Ver. 10-18 Rev

Claimant's Name	Claimant's Home Address	Department
JAMES E. DOE	88 BITHOME ST, PRUMYNA, VA	PLANNING

Travel / Expense Purpose <small>(Attach Training/Conference Brochure or other explanatory information)</small>	Travel Category (check one)
VACO PLANNING SEMINAR, Omni HOTEL, RICHMOND	<input checked="" type="checkbox"/> Day Travel (50+ miles one way) <input type="checkbox"/> Overnight Travel <input type="checkbox"/> Local Travel (within 50 miles)

TRAVEL DAY	1	2	3	4	5	6	7
Date	10/2/18	10/2/18					
Departure Time	7:00AM	4:00PM					
Departed From	Home	RICHMOND					
Arrival Time	8:15AM	5:30PM					
Arrived At	RICHMOND	Home					

Sample #3

CATEGORY	ACTUAL EXPENSES <small>(Receipts required, except for M&IE)</small>							TOTAL
POV Mileage	63	63						\$ 68.67
Airfare or Rail								\$ -
Car Rental								\$ -
Taxi/Bus								\$ -
Parking & Tolls	\$ 12							\$ 12.00
Lodging								\$ -
M&IE Per Diem	\$ 17							\$ 17.00
Conf./Registration Fee	25							\$ 25.00
								\$ -
								\$ -
								\$ -

<small>Mileage rate per mile effective Jan 1, 2018</small>	\$0.545	Normal commuting mileage to / from home is not reimbursable.	Less Travel Advance Rcvd	\$ -
CONFERENCE FEE PAID ON COUNTY CREDIT CARD			Less County Prepaid Expenses	\$ 25.00
			TOTAL REIMBURSEMENT REQUEST	\$ 97.67

I certify this claim is true to the best of my knowledge, that no part of the amounts claimed have been paid (unless otherwise noted), and that all expenditures claimed were made in the discharge of official duties.	I have reviewed this travel claim.	I approve submission of this travel claim to Finance for final review and processing.
Claimant Signature and Date	Supervisor / Dept Head Signature and Date	Approving Official Signature and Date

Reimbursement Category	Org #	Object #	Total

MEMORANDUM

TAB C

Date: November 20, 2018
From: Finance Department
To: Board of Supervisors
Subject: **Accounts Payable Report for October 2018**

1. Staff recommends that the Board of Supervisors ratify the expenditures in the attached report and summarized below.

CATEGORY	AMOUNT
General	\$1,105,684.52
Capital Improvements	\$161,490.94
Debt Service	\$0.00
Sewer	\$646.81
Fork Union Sanitary District	\$13,025.93
Zion Crossroads Water & Sewer	\$12,782.50
TOTAL AP EXPENDITURES	\$1,293,630.70
Payroll	\$829,000.34
TOTAL	\$2,122,631.04

MOTION

I move the Accounts Payable and Payroll be ratified for **October 2018** in the amount of **\$2,122,631.04**.

Encl:
AP Report

**County of Fluvanna
Accounts Payable List**

**From Date: 10/1/2018
To Date: 10/31/2018**



Vendor Name	Charge To	Description	Invoice Number	Invoice Date	Check Date	Check Amount
Fund # - 100 GENERAL FUND						
GENERAL FUND						
MINNESOTA LIFE INS. CO	CLEARING ACCOUNT- PAYROLL	Payroll Run 1 - Warrant 092118	000000064523	9/20/2018	10/5/2018	159.46
MINNESOTA LIFE INS. CO	CLEARING ACCOUNT- PAYROLL	Payroll Run 1 - Warrant 090718	000000064160	9/6/2018	10/5/2018	159.50
MINNESOTA LIFE INS. CO	CLEARING ACCOUNT- PAYROLL	Payroll Run 1 - Warrant 101918	000000065181	10/18/2018	10/25/2018	159.46
MINNESOTA LIFE INS. CO	CLEARING ACCOUNT- PAYROLL	Payroll Run 1 - Warrant 100518	000000064756	10/4/2018	10/25/2018	159.50
DOMINION ENERGY	CUSTOMERS	SIGN DEPOSIT REFUND - SUP 18:03 BEN	SUP 18:03	8/20/2018	10/12/2018	90.00
VACORP	CLEARING ACCOUNT- PAYROLL	Payroll Run 1 - Warrant 092118	000000064524	9/20/2018	10/5/2018	548.95
VACORP	CLEARING ACCOUNT- PAYROLL	Payroll Run 1 - Warrant 090718	000000064161	9/6/2018	10/5/2018	562.93
VACORP	CLEARING ACCOUNT- PAYROLL	Payroll Run 1 - Warrant 101918	000000065182	10/18/2018	10/25/2018	530.84
VACORP	CLEARING ACCOUNT- PAYROLL	Payroll Run 1 - Warrant 100518	000000064757	10/4/2018	10/25/2018	560.18
Total:						\$2,930.82
PERSONAL PROPERTY TAXES						
CHAMBERS, FRANCINE MARIA	P P 2018 - 1ST	PP 2018 214739	63968	8/29/2018	10/5/2018	20.04
CHAMBERS, FRANCINE MARIA	P P 2018 - 1ST	PP 2018 214739	63968	8/29/2018	10/5/2018	40.40
CHAMBERS, FRANCINE MARIA	P P 2018 - 2ND	PP 2018 214739	63968	8/29/2018	10/5/2018	20.03
SHORT, RACHEL CLORE BROWN	P P 2018 - 1ST	PP 2018 15194	63969	8/29/2018	10/5/2018	352.46
Total:						\$432.93
OTHER LOCAL TAXES						
CHAMBERS, FRANCINE MARIA	ADMIN FEE VEHICLE LICENSE	PP 2018 214739	63968	8/29/2018	10/5/2018	12.97
CHAMBERS, FRANCINE MARIA	ADMIN FEE VEHICLE LICENSE	PP 2018 214739	63968	8/29/2018	10/5/2018	33.00
GLASSCOCK, ROGER BERRY	ADMIN FEE VEHICLE LICENSE	PP 2018 217804	64189	9/7/2018	10/5/2018	1.87
SHORT, RACHEL CLORE BROWN	ADMIN FEE VEHICLE LICENSE	PP 2018 15194	63969	8/29/2018	10/5/2018	33.00
Total:						\$80.84
CHARGES FOR SERVICES						
EMS MANAGEMENT & CONSULTANTS,	EMS COST RECOVERY	NPP LETTERS	034259	9/30/2018	10/12/2018	(\$584.93)
Total:						(\$584.93)
STATE - CATEGORICAL AID						
TREASURER OF VIRGINIA	VJCCA GRANT OFFICE ON	REFUND OF FUNDS NOT EXPENDED FOR	100118	10/1/2018	10/26/2018	389.30
Total:						\$389.30
BOARD OF SUPERVISORS						
BANK OF AMERICA	OTHER OPERATING SUPPLIES	P-CARD	093018	9/30/2018	10/16/2018	29.68
DONALD WEAVER	MILEAGE ALLOWANCES	MILEAGE	092018	9/20/2018	10/5/2018	243.62

**County of Fluvanna
Accounts Payable List**

**From Date: 10/1/2018
To Date: 10/31/2018**



FLUVANNA REVIEW	ADVERTISING	COUNTY LEGAL RATE AD	2018F40-11	10/4/2018	10/12/2018	128.75
FLUVANNA REVIEW	ADVERTISING	PUBLIC HEARING/MEALS TAX ADS	2018F41-11	10/11/2018	10/19/2018	295.00
FLUVANNA REVIEW	ADVERTISING	POPSD MEAL TAX AD	2018F42-9	10/18/2018	10/26/2018	166.25
VERIZON	TELECOMMUNICATIONS	MONTHLY CHARGES	721970783-00001 1019	10/19/2018	10/26/2018	140.37
VIRGINIA CORRECTIONAL	PRINTING AND BINDING	MEAL TAX PRINTING	9544846	9/28/2018	10/12/2018	160.00
Total:						\$1,163.67
COUNTY ADMINISTRATOR						
BANK OF AMERICA	CONVENTION AND EDUCATION	P-CARD	093018	9/30/2018	10/16/2018	290.00
BANK OF AMERICA	OTHER OPERATING SUPPLIES	P-CARD	093018	9/30/2018	10/16/2018	10.95
CANON FINANCIAL SERVICES, INC.	LEASE/RENT	COPIER MONTHLY CHARGES	19235147	9/21/2018	10/5/2018	223.00
CANON FINANCIAL SERVICES, INC.	LEASE/RENT	COPIER MONTHLY CHARGES	19279789	10/13/2018	10/26/2018	223.00
KELLY HARRIS	MILEAGE ALLOWANCES	FOIA TRAINING MILEAGE	101118	10/11/2018	10/12/2018	71.94
KELLY HARRIS	SUBSISTENCE & LODGING	TRAVEL ADVANCE	101918	10/19/2018	10/22/2018	152.50
PITNEY BOWES PURCHASE PWR	POSTAL SERVICES	POSTAGE	01515654 101818	10/16/2018	10/26/2018	6.57
STAPLES CONTRACT & COMMERCIAL,	OFFICE SUPPLIES	OFFICE SUPPLIES	8051666987	10/6/2018	10/19/2018	26.89
STEVEN NICHOLS	MILEAGE ALLOWANCES	JRWA PROJECT MEETING MILEAGE	101118	10/11/2018	10/12/2018	68.67
VERIZON	TELECOMMUNICATIONS	MONTHLY CHARGES	721970783-00001 1019	10/19/2018	10/26/2018	50.18
VIRGINIA BUSINESS SYSTEMS	LEASE/RENT	COPIER	23394332	9/20/2018	10/5/2018	231.90
VIRGINIA BUSINESS SYSTEMS	LEASE/RENT	KONICA STAPLER FINISHER	23452975	10/1/2018	10/19/2018	47.59
Total:						\$1,403.19
COUNTY ATTORNEY						
PAYNE & HODOUS, LLP.	COUNTY ATTY LEGAL- GENERAL	LEGAL FEES	132632	10/3/2018	10/19/2018	10,000.00
PAYNE & HODOUS, LLP.	COUNTY ATTY LEGAL-	LEGAL FEES	132632	10/3/2018	10/19/2018	4,970.00
PAYNE & HODOUS, LLP.	COUNTY ATTY LEGAL-	LEGAL FEES	132632	10/3/2018	10/19/2018	4,092.25
PAYNE & HODOUS, LLP.	COUNTY ATTY LEGAL- REAL	LEGAL FEES	132632	10/3/2018	10/19/2018	106.00
Total:						\$19,168.25
COMMISSIONER OF THE REVENUE						
ANDREW SHERIDAN	SUBSISTENCE & LODGING	TRAVEL REIMBURSEMENT	10/26/18	10/19/2018	10/26/2018	183.50
BANK OF AMERICA	BLDGS EQUIP REP & MAINT	P-CARD	093018	9/30/2018	10/16/2018	32.45
BANK OF AMERICA	FURNITURE & FIXTURES	P-CARD	093018	9/30/2018	10/16/2018	208.80
BANK OF AMERICA	POSTAL SERVICES	P-CARD	093018	9/30/2018	10/16/2018	54.00
BANK OF AMERICA	SUBSISTENCE & LODGING	P-CARD	093018	9/30/2018	10/16/2018	14.79
BANK OF AMERICA	SUBSISTENCE & LODGING	P-CARD	093018	9/30/2018	10/16/2018	27.55
BANK OF AMERICA	SUBSISTENCE & LODGING	P-CARD	093018	9/30/2018	10/16/2018	815.16
BANK OF AMERICA	SUBSISTENCE & LODGING	P-CARD	093018	9/30/2018	10/16/2018	833.16
CAITLIN SOLIS	SUBSISTENCE & LODGING	TRAVEL REIMBURSEMENT	10/26/18	10/19/2018	10/26/2018	231.50

**County of Fluvanna
Accounts Payable List**

**From Date: 10/1/2018
To Date: 10/31/2018**



JAMES RIVER SOLUTIONS	VEHICLE FUEL	FUEL	100218	10/2/2018	10/12/2018	16.66
PALMYRA PRESS, INC.	PRINTING AND BINDING	ENVELOPES	3381	9/27/2018	10/5/2018	387.00
PITNEY BOWES PURCHASE PWR	POSTAL SERVICES	POSTAGE	48002653 092418	9/24/2018	10/5/2018	1,500.00
STONEWALL TECHNOLOGIES	PROFESSIONAL SERVICES	VAMANET PUBLIC SITE	9112	9/30/2018	10/12/2018	300.00
THE SUPPLY ROOM	OFFICE SUPPLIES	PAPER	3470709-0	10/16/2018	10/26/2018	37.46
VERIZON	TELECOMMUNICATIONS	MONTHLY CHARGES	721970783-00001 1019	10/19/2018	10/26/2018	50.18
Total:						\$4,692.21
<hr/>						
REASSESSMENT						
PEARSON'S APPRAISAL SERVICE INC	PROFESSIONAL SERVICES	2019 ADMINISTRATIVE REVIEW	2	10/9/2018	10/12/2018	35,875.00
Total:						\$35,875.00
<hr/>						
TREASURER						
BMS DIRECT	PRINTING AND BINDING	REAL ESTATE 2ND HALF 2018	128476	10/9/2018	10/19/2018	1,590.45
BMS DIRECT	PRINTING AND BINDING	PERSONAL PROPERTY 2ND HALF BILLING	129434	10/9/2018	10/19/2018	3,553.68
CANON FINANCIAL SERVICES, INC.	LEASE/RENT	COPIER MONTHLY CHARGES	19235147	9/21/2018	10/5/2018	125.00
CANON FINANCIAL SERVICES, INC.	LEASE/RENT	COPIER MONTHLY CHARGES	19279789	10/13/2018	10/26/2018	125.00
MECHUMS RIVER SECURITY	LEASE/RENT	QUARTERLY MONITORING	12267	7/1/2018	10/12/2018	60.00
MECHUMS RIVER SECURITY	LEASE/RENT	QUARERLY MONITORING	13683	10/1/2018	10/12/2018	60.00
QUILL	OFFICE SUPPLIES	STAPLES	1246419	9/18/2018	10/12/2018	10.99
QUILL	OFFICE SUPPLIES	OFFICE SUPPLIES	1254186	9/18/2018	10/12/2018	229.30
QUILL	OFFICE SUPPLIES	STAPLERS	1254469	9/18/2018	10/19/2018	29.97
VERIZON	TELECOMMUNICATIONS	MONTHLY CHARGES	721970783-00001 1019	10/19/2018	10/26/2018	50.18
VIRGINIA BUSINESS SYSTEMS	OFFICE SUPPLIES	KONICA BIZHUB 363	23452976	10/1/2018	10/19/2018	131.38
VIRGINIA DEPT. OF MOTOR VEHICLES	DMV-ONLINE	STOPS REMOVED	546001282025 101818	10/18/2018	10/26/2018	2,425.00
Total:						\$8,390.95
<hr/>						
INFORMATION TECHNOLOGY						
BANK OF AMERICA	ADP SERVICES	P-CARD	093018	9/30/2018	10/16/2018	8.25
BANK OF AMERICA	ADP SERVICES	P-CARD	093018	9/30/2018	10/16/2018	9.70
BANK OF AMERICA	ADP SERVICES	P-CARD	093018	9/30/2018	10/16/2018	25.00
BANK OF AMERICA	ADP SERVICES	P-CARD	093018	9/30/2018	10/16/2018	119.00
BANK OF AMERICA	ADP SERVICES	P-CARD	093018	9/30/2018	10/16/2018	199.99
BANK OF AMERICA	ADP SERVICES	P-CARD	093018	9/30/2018	10/16/2018	388.81
BANK OF AMERICA	ADP SERVICES	P-CARD	093018	9/30/2018	10/16/2018	591.29
BANK OF AMERICA	ADP SUPPLIES	P-CARD	093018	9/30/2018	10/16/2018	21.02
BANK OF AMERICA	ADP SUPPLIES	P-CARD	093018	9/30/2018	10/16/2018	26.79
BANK OF AMERICA	ADP SUPPLIES	P-CARD	093018	9/30/2018	10/16/2018	45.70
BANK OF AMERICA	ADP SUPPLIES	P-CARD	093018	9/30/2018	10/16/2018	50.40

**County of Fluvanna
Accounts Payable List**

**From Date: 10/1/2018
To Date: 10/31/2018**



BANK OF AMERICA	ADP SUPPLIES	P-CARD	093018	9/30/2018	10/16/2018	71.90
BANK OF AMERICA	ADP SUPPLIES	P-CARD	093018	9/30/2018	10/16/2018	105.29
BANK OF AMERICA	ADP SUPPLIES	P-CARD	093018	9/30/2018	10/16/2018	186.05
BANK OF AMERICA	BOOKS/PUBLICATIONS	P-CARD	093018	9/30/2018	10/16/2018	83.67
CANON FINANCIAL SERVICES, INC.	LEASE/RENT	COPIER MONTHLY CHARGES	19235147	9/21/2018	10/5/2018	57.00
CANON FINANCIAL SERVICES, INC.	LEASE/RENT	COPIER MONTHLY CHARGES	19279789	10/13/2018	10/26/2018	57.00
CDW GOVERNMENT, INC.	ADP SERVICES	ELECTRONIC SUPPLIES	PGV1293	9/19/2018	10/5/2018	100.64
CDW GOVERNMENT, INC.	ADP SERVICES	ELECTRONIC SUPPLIES	PJT5993	9/26/2018	10/5/2018	1,559.00
DELL MARKETING, L.P.	EDP EQUIPMENT	DELL LATITUDE	10269920710	10/1/2018	10/5/2018	1,578.39
DELL MARKETING, L.P.	EDP EQUIPMENT	MEMORY UPGRADE	10270651067	10/4/2018	10/12/2018	411.62
DELL MARKETING, L.P.	EDP EQUIPMENT	DELL LATITUDE/DELL DOCK	10271363637	10/9/2018	10/12/2018	1,006.04
ER COMMUNICATIONS LLC	PROFESSIONAL SERVICES	REPAIRS	1262	9/28/2018	10/5/2018	190.00
ER COMMUNICATIONS LLC	PROFESSIONAL SERVICES	SUPPLIES	1257	9/19/2018	10/5/2018	498.75
MECHUMS RIVER SECURITY	PROFESSIONAL SERVICES	SERVICE CALL	12549	6/30/2018	10/12/2018	80.00
MICROSOFT AZURE	ADP SERVICES	SOFTWARE	E08006O0BL	9/16/2018	10/12/2018	166.46
MICROSOFT AZURE	ADP SERVICES	USAGE CHARGES	E08006VN08	10/16/2018	10/26/2018	330.97
PROGENT CORPORATION	ADP SERVICES	REMOTE SERVICES	131527	6/30/2018	10/19/2018	110.25
THE SUPPLY ROOM	OFFICE SUPPLIES	PAPER	3454916-0	10/2/2018	10/12/2018	48.31
TYLER TECHNOLOGIES	ADP SERVICES	APPLICATION SRVICES 10/1/18 - 12/31/18	045-240686	10/1/2018	10/19/2018	40,662.00
VERIZON	TELECOMMUNICATIONS	MONTHLY CHARGES	721970783-00001 1019	10/19/2018	10/26/2018	940.36
Total:						\$49,729.65

FINANCE

BANK OF AMERICA	CONVENTION AND EDUCATION	P-CARD	093018	9/30/2018	10/16/2018	20.00
BANK OF AMERICA	CONVENTION AND EDUCATION	P-CARD	093018	9/30/2018	10/16/2018	225.00
BANK OF AMERICA	DUES OR ASSOCIATION	P-CARD	093018	9/30/2018	10/16/2018	39.95
CANON FINANCIAL SERVICES, INC.	LEASE/RENT	COPIER MONTHLY CHARGES	19235147	9/21/2018	10/5/2018	223.00
CANON FINANCIAL SERVICES, INC.	LEASE/RENT	COPIER MONTHLY CHARGES	19279789	10/13/2018	10/26/2018	223.00
DRIVEERT	MILEAGE ALLOWANCES	TOLLS	1003778686	9/19/2018	10/12/2018	25.00
EMS MANAGEMENT & CONSULTANTS,	CONTRACT SERVICES	NPP LETTERS	034259	9/30/2018	10/12/2018	1,532.53
PITNEY BOWES PURCHASE PWR	POSTAL SERVICES	POSTAGE	01515654 101818	10/16/2018	10/26/2018	125.29
STAPLES CONTRACT & COMMERCIAL,	OFFICE SUPPLIES	OFFICE SUPPLIES	8051666987	10/6/2018	10/19/2018	65.06
UPS	POSTAL SERVICES	2ND DAY LETTER	0000Y7646Y398	9/29/2018	10/12/2018	7.23
VERIZON	TELECOMMUNICATIONS	MONTHLY CHARGES	721970783-00001 1019	10/19/2018	10/26/2018	50.18
VIRGINIA BUSINESS SYSTEMS	LEASE/RENT	COPIER	23394333	9/20/2018	10/5/2018	169.45
VIRGINIA BUSINESS SYSTEMS	LEASE/RENT	KONICA BIZHUB 363	23568962	10/22/2018	10/26/2018	169.45
Total:						\$2,875.14

REGISTRAR/ELECTORAL BOARD

**County of Fluvanna
Accounts Payable List**

**From Date: 10/1/2018
To Date: 10/31/2018**



AUTOMATED OFFICE SYSTEMS	LEASE/RENT	MONTHLY CHARGES	083232	10/2/2018	10/5/2018	155.00
BANK OF AMERICA	POSTAL SERVICES	P-CARD	093018	9/30/2018	10/16/2018	7.77
BANK OF AMERICA	POSTAL SERVICES	P-CARD	093018	9/30/2018	10/16/2018	11.10
BANK OF AMERICA	POSTAL SERVICES	P-CARD	093018	9/30/2018	10/16/2018	17.76
BANK OF AMERICA	POSTAL SERVICES	P-CARD	093018	9/30/2018	10/16/2018	18.87
BANK OF AMERICA	POSTAL SERVICES	P-CARD	093018	9/30/2018	10/16/2018	49.95
BANK OF AMERICA	POSTAL SERVICES	P-CARD	093018	9/30/2018	10/16/2018	54.39
BENJ. FRANKLIN PRINTING CO.	OFFICE SUPPLIES	ENVELOPES	40090	9/17/2018	10/5/2018	209.00
DANIEL D. GRAFF	SUBSISTENCE & LODGING	MEALS DURING ELECTION DAY PREP	89/25/2018	9/25/2018	10/5/2018	41.90
JOYCE PACE	MILEAGE ALLOWANCES	MILEAGE REIMBURSEMENT	100918	10/9/2018	10/12/2018	121.54
THE DAILY PROGRESS	POSTAL SERVICES	RURAL VIRGINIAN AD	3388294 093018	9/30/2018	10/12/2018	115.00
VERIZON	TELECOMMUNICATIONS	MONTHLY CHARGES	721970783-00001 1019	10/19/2018	10/26/2018	50.18
Total:						\$852.46
HUMAN RESOURCES						
BANK OF AMERICA	EMPLOYEE RECOGNITION	P-CARD	093018	9/30/2018	10/16/2018	189.55
BANK OF AMERICA	RECRUITMENT	P-CARD	093018	9/30/2018	10/16/2018	148.80
BANK OF AMERICA	RECRUITMENT	P-CARD	093018	9/30/2018	10/16/2018	180.00
CANON FINANCIAL SERVICES, INC.	LEASE/RENT	COPIER MONTHLY CHARGES	19235147	9/21/2018	10/5/2018	43.00
CANON FINANCIAL SERVICES, INC.	LEASE/RENT	COPIER MONTHLY CHARGES	19279789	10/13/2018	10/26/2018	11.35
CANON FINANCIAL SERVICES, INC.	LEASE/RENT	COPIER MONTHLY CHARGES	19279789	10/13/2018	10/26/2018	54.35
FLUVANNA REVIEW	RECRUITMENT	FACILITY MAINTENANCE SPECIALIST AD	2018F39-8	9/27/2018	10/5/2018	63.00
MCLAUGHLIN YOUNG EMPLOYEE	PROFESSIONAL SERVICES	EMPLOYEE ASSISTANCE PROGRAM	50472	10/16/2018	10/19/2018	251.22
PIERCE GROUP BENEFITS	PROFESSIONAL SERVICES	ENROLLMENT SYSTEM FEE/BROKER FEE	28 FLUVANNA	10/1/2018	10/5/2018	1,348.00
STAPLES CONTRACT & COMMERCIAL,	OFFICE SUPPLIES	OFFICE SUPPLIES	8051666987	10/6/2018	10/19/2018	75.57
VIRGINIA BUSINESS SYSTEMS	LEASE/RENT	COPIER	23411160	9/24/2018	10/5/2018	44.80
Total:						\$2,409.64
GENERAL DISTRICT COURT						
CENTURYLINK	MAINTENANCE CONTRACTS	DISTRICT COURT	309871364 091718	9/16/2018	10/5/2018	234.13
VIRGINIA BUSINESS SYSTEMS	MAINTENANCE CONTRACTS	COPIER	23423740	9/25/2018	10/5/2018	161.51
Total:						\$395.64
COURT SERVICE UNIT						
DENNIS CRONIN	MILEAGE ALLOWANCES	MILEAGE REIMBURSEMENT	101118	10/11/2018	10/12/2018	67.41
Total:						\$67.41
CLERK OF THE CIRCUIT COURT						
CHARLOTTESVILLE OFFICE MACHINE	OFFICE SUPPLIES	DATE STAMPER RIBBON	673020	10/17/2018	10/26/2018	10.00

**County of Fluvanna
Accounts Payable List**

**From Date: 10/1/2018
To Date: 10/31/2018**



LOGAN SYSTEMS, INC.	PROFESSIONAL SERVICES	PROFESSIONAL SERVICES	51588	10/15/2018	10/19/2018	2,541.67
STAPLES CONTRACT & COMMERCIAL,	OFFICE SUPPLIES	OFFICE SUPPLIES	8051666987	10/6/2018	10/19/2018	800.19
THE SUPPLY ROOM	OFFICE SUPPLIES	PAPER	3448058-0	9/25/2018	10/5/2018	117.72
TRISTANA TREADWAY	MILEAGE ALLOWANCES	TRAVEL REIMBURSEMENT	10/26/18	10/24/2018	10/26/2018	332.80
U.S. POSTAL SERVICE	POSTAL SERVICES	POSTAGE	36694560 100218	10/2/2018	10/5/2018	1,000.00
VINCENT RIZZO	MILEAGE ALLOWANCES	TRAVEL REIMBURSEMENT	102618	10/17/2018	10/26/2018	306.18
VIRGINIA BUSINESS SYSTEMS	LEASE/RENT	KONICA BIZHUB C284e	23530661	10/15/2018	10/26/2018	205.83
Total:						\$5,314.39
<hr/>						
CIRCUIT COURT JUDGE						
CATHY ALLEN	OFFICE SUPPLIES	JURY COMMISSIONERS REFRESHMENTS	101818	10/18/2018	10/19/2018	17.17
TRISTANA TREADWAY	OFFICE SUPPLIES	JURY COMMISSIONER LUNCH	101818	10/18/2018	10/19/2018	27.20
TRISTANA TREADWAY	OFFICE SUPPLIES	GRAND JURY REFRESHMENTS	102218	10/22/2018	10/26/2018	13.59
Total:						\$57.96
<hr/>						
COMMONWEALTH ATTY						
BANK OF AMERICA	OTHER OPERATING SUPPLIES	P-CARD	093018	9/30/2018	10/16/2018	68.20
COMPUTER PROJECTS OF ILLINOIS	MAINTENANCE CONTRACTS	OPENFOX MEESENGER LICENSE AND	18-10-138ME	10/15/2018	10/26/2018	173.40
MATTHEW BENDER & CO INC	MAINTENANCE CONTRACTS	LEXIS NEXIS (SEPTEMBER 2018)	3091684924	9/30/2018	10/5/2018	136.00
THE SUPPLY ROOM	OFFICE SUPPLIES	OFFICE SUPPLIES	3451425-0	9/27/2018	10/5/2018	110.04
THE SUPPLY ROOM	OFFICE SUPPLIES	DESK CALENDAR	3451425-1	10/9/2018	10/19/2018	4.74
THE SUPPLY ROOM	OFFICE SUPPLIES	PAPER TOWELS	3462072-0	10/8/2018	10/19/2018	24.84
VERIZON	TELECOMMUNICATIONS	MONTHLY CHARGES	721970783-00001 1019	10/19/2018	10/26/2018	50.18
Total:						\$567.40
<hr/>						
SHERIFF						
ADVANCE AUTO PARTS	VEHICLE/POWER EQUIP	OIL FILTER	7306827166081	9/28/2018	10/5/2018	6.61
ADVANCE AUTO PARTS	VEHICLE/POWER EQUIP	ENGINE OIL FILTER	7306826866006	9/28/2018	10/5/2018	9.99
ADVANCE AUTO PARTS	VEHICLE/POWER EQUIP	VEHICLE PARTS	7306828840884	10/15/2018	10/26/2018	4.54
AMERICAN PET RESORT, LLC	CONTRACT SERVICES	DOG BOARDING	423361	9/26/2018	10/5/2018	1,260.00
AMERICAN UNIFORM SALES, INC	UNIFORM/WEARING APPAREL	UNIFORM SHIRTS	00052189	9/27/2018	10/5/2018	64.02
AMERICAN UNIFORM SALES, INC	UNIFORM/WEARING APPAREL	SHIRTS	00052265	10/3/2018	10/12/2018	47.22
AMERICAN UNIFORM SALES, INC	UNIFORM/WEARING APPAREL	SHIRTS/PATCHES	00052266	10/3/2018	10/12/2018	301.72
AT&T 286-3642	TELECOMMUNICATIONS	LONG DISTANCE	7305055828001 100618	10/6/2018	10/26/2018	42.70
BANK OF AMERICA	FOOD SUPPLIES	P-CARD	093018	9/30/2018	10/16/2018	26.18
BANK OF AMERICA	OFFICE SUPPLIES	P-CARD	093018	9/30/2018	10/16/2018	98.66
BANK OF AMERICA	OTHER OPERATING SUPPLIES	P-CARD	093018	9/30/2018	10/16/2018	21.01
BANK OF AMERICA	POLICE SUPPLIES	P-CARD	093018	9/30/2018	10/16/2018	28.83
BANK OF AMERICA	POLICE SUPPLIES	P-CARD	093018	9/30/2018	10/16/2018	55.74

**County of Fluvanna
Accounts Payable List**

**From Date: 10/1/2018
To Date: 10/31/2018**



BANK OF AMERICA	SUBSISTENCE & LODGING	P-CARD	093018	9/30/2018	10/16/2018	10.93
BANK OF AMERICA	SUBSISTENCE & LODGING	P-CARD	093018	9/30/2018	10/16/2018	12.02
BANK OF AMERICA	SUBSISTENCE & LODGING	P-CARD	093018	9/30/2018	10/16/2018	15.28
BANK OF AMERICA	SUBSISTENCE & LODGING	P-CARD	093018	9/30/2018	10/16/2018	17.74
BANK OF AMERICA	SUBSISTENCE & LODGING	P-CARD	093018	9/30/2018	10/16/2018	19.95
BANK OF AMERICA	SUBSISTENCE & LODGING	P-CARD	093018	9/30/2018	10/16/2018	25.00
BANK OF AMERICA	SUBSISTENCE & LODGING	P-CARD	093018	9/30/2018	10/16/2018	26.16
BANK OF AMERICA	SUBSISTENCE & LODGING	P-CARD	093018	9/30/2018	10/16/2018	26.85
BANK OF AMERICA	SUBSISTENCE & LODGING	P-CARD	093018	9/30/2018	10/16/2018	131.21
BANK OF AMERICA	VEHICLE/POWER EQUIP	P-CARD	093018	9/30/2018	10/16/2018	5.00
BANK OF AMERICA	VEHICLE/POWER EQUIP	P-CARD	093018	9/30/2018	10/16/2018	15.00
BANK OF AMERICA	VEHICLES REP & MAINT	P-CARD	093018	9/30/2018	10/16/2018	22.00
CAMPBELL EQUIPMENT, INC.	VEHICLES REP & MAINT	MOUNT/BALANCE AND DISPOSAL	92618	9/26/2018	10/5/2018	96.00
CANON FINANCIAL SERVICES, INC.	LEASE/RENT	COPIER MONTHLY CHARGES	19235147	9/21/2018	10/5/2018	80.95
CANON FINANCIAL SERVICES, INC.	LEASE/RENT	COPIER MONTHLY CHARGES	19279789	10/13/2018	10/26/2018	80.95
CENTURYLINK	TELECOMMUNICATIONS	SHERIFFS OFFICE	309797542 091618	9/16/2018	10/5/2018	165.27
CENTURYLINK	TELECOMMUNICATIONS	SHERIFFS OFFICE	310191749 091618	9/16/2018	10/5/2018	890.89
CENTURYLINK	TELECOMMUNICATIONS	SHERIFF	309903768 100718	10/7/2018	10/26/2018	154.46
CITY OF CHARLOTTESVILLE	CONTRACT SERVICES	TJ AREA CRISIS INTERVENTION TEAM	MISC-INV_CIT2018	9/17/2018	10/5/2018	1,662.50
CLEAR COMMUNICATIONS AND	VEHICLES REP & MAINT	RADIO	117273	9/27/2018	10/5/2018	227.98
CLEAR COMMUNICATIONS AND	VEHICLES REP & MAINT	REPAIRS	117428	10/11/2018	10/26/2018	205.45
COMSONICS INC	VEHICLES REP & MAINT	RADAR/TUNING FORKS	842251	9/19/2018	10/5/2018	94.92
EZ SYSTEMZ INC.	EDP EQUIPMENT	EZ CHILD ID ALL IN ONE MOBILE SYSTEM	12759	9/4/2018	10/19/2018	6,499.62
FLUVANNA CO PUBLIC SCHOOLS	VEHICLE/POWER EQUIP	KEY FOBS	092018-01	9/20/2018	10/5/2018	10.00
FLUVANNA REVIEW	ADVERTISING	SENIOR TRIAD DAY AD	2018F42-10	10/18/2018	10/26/2018	80.00
FLUVANNA SPCA	CONTRACT SERVICES	ANIMAL SHERLTERING SERVICES: FY19	100118	10/1/2018	10/5/2018	50,318.50
GALLS, LLC.	UNIFORM/WEARING APPAREL	TACTICAL PANTS	010812471	9/20/2018	10/5/2018	42.72
GALLS, LLC.	UNIFORM/WEARING APPAREL	SGT STRIPES	010812371	9/20/2018	10/5/2018	110.04
GALLS, LLC.	UNIFORM/WEARING APPAREL	UNIFORM SUPPLIES	010801516	9/19/2018	10/5/2018	413.00
GALLS, LLC.	UNIFORM/WEARING APPAREL	GEAR KIT	010836738	9/24/2018	10/12/2018	96.79
GALLS, LLC.	UNIFORM/WEARING APPAREL	SHOES	010894772	10/1/2018	10/12/2018	200.00
GALLS, LLC.	UNIFORM/WEARING APPAREL	TACTICAL BOOT	010902835	10/2/2018	10/26/2018	77.01
GALLS, LLC.	UNIFORM/WEARING APPAREL	RAIN COAT, TACTICAL PANTS	010932702	10/5/2018	10/26/2018	172.98
JAMES RIVER SOLUTIONS	VEHICLE FUEL	FUEL	100218	10/2/2018	10/12/2018	6,001.61
LYNN CARD COMPANY	OFFICE SUPPLIES	CARDS	2180920-025	10/1/2018	10/12/2018	150.50
MANSFIELD OIL COMPANY OF	VEHICLE FUEL	FUEL 9/16/18- 9/30/18	SQLCD-449684	10/2/2018	10/5/2018	179.13
MANSFIELD OIL COMPANY OF	VEHICLE FUEL	FUELS INVOICE 10/01/18 - 10/15/18	SQLCD-452785	10/16/2018	10/19/2018	300.58
PITNEY BOWES PURCHASE PWR	OFFICE SUPPLIES	METER REFILL	0215 092018	9/20/2018	10/5/2018	1,020.99
PSYCHOLOGICAL HEALTH ROANOKE	PROFESSIONAL SERVICES	POLICE TESTING	C-C-16075	9/28/2018	10/12/2018	90.00

**County of Fluvanna
Accounts Payable List**

**From Date: 10/1/2018
To Date: 10/31/2018**



PSYCHOLOGICAL HEALTH ROANOKE	PROFESSIONAL SERVICES	POLICE TESTING	W-C-16074	9/28/2018	10/12/2018	90.00
SHULL'S AUTOMOTIVE, INC.	VEHICLES REP & MAINT	INSPECTION	10019299	9/21/2018	10/5/2018	16.00
SHULL'S AUTOMOTIVE, INC.	VEHICLES REP & MAINT	OIL CHANGE	10019300	9/27/2018	10/12/2018	14.00
SHULL'S AUTOMOTIVE, INC.	VEHICLES REP & MAINT	OIL FILTER	10019301	9/29/2018	10/12/2018	14.00
SHULL'S AUTOMOTIVE, INC.	VEHICLES REP & MAINT	STATE INSPECTION	10019302	9/28/2018	10/12/2018	16.00
SHULL'S AUTOMOTIVE, INC.	VEHICLES REP & MAINT	OIL CHANGE	10019303	10/3/2018	10/19/2018	14.00
SHULL'S AUTOMOTIVE, INC.	VEHICLES REP & MAINT	CAR MAINTENANCE	10019304	10/8/2018	10/19/2018	84.00
SHULL'S AUTOMOTIVE, INC.	VEHICLES REP & MAINT	OIL CHANGE	10019305	10/17/2018	10/26/2018	14.00
SPRINT	TELECOMMUNICATIONS	MONTHLY CHARGES	313771602-005	9/26/2018	10/12/2018	963.59
STAPLES CONTRACT & COMMERCIAL,	OFFICE SUPPLIES	OFFICE SUPPLIES	8051666987	10/6/2018	10/19/2018	140.48
VALLEY OFFICE MACHINES, INC.	MAINTENANCE CONTRACTS	COPIER CHARGES	523778	9/19/2018	10/5/2018	50.70
VALLEY OFFICE MACHINES, INC.	MAINTENANCE CONTRACTS	COPIER CHARGES	523777	9/19/2018	10/5/2018	104.59
VALLEY OFFICE MACHINES, INC.	MAINTENANCE CONTRACTS	COPY CHARGES	531131	10/10/2018	10/26/2018	28.04
VALLEY OFFICE MACHINES, INC.	MAINTENANCE CONTRACTS	COPY CHARGES	531199	10/10/2018	10/26/2018	76.98
VERIZON BUSINESS/MCI COMM	TELECOMMUNICATIONS	MONTHLY CHARGES	05619915	9/25/2018	10/5/2018	19.06
VERIZON	TELECOMMUNICATIONS	MONTHLY CHARGES	921953702-0001 1031	10/8/2018	10/26/2018	1,088.75
VIRGINIA BUSINESS SYSTEMS	LEASE/RENT	KONICA 364E	23452978	10/1/2018	10/26/2018	77.72
VIRGINIA DEPT. OF MOTOR VEHICLES	OFFICE SUPPLIES	SPECIAL IDS	18271682	9/28/2018	10/12/2018	20.00
WATCH GUARD	MAINTENANCE CONTRACTS	SOFTWARE ROTECTION, EVIDENCE	QUO-67044-L0W6	9/27/2018	10/12/2018	3,339.25
WATCH GUARD	MAINTENANCE CONTRACTS	WARRANTY	QUO-32264-G3G6	9/27/2018	10/12/2018	5,068.25
WELLS FARGO VENDOR FIN SERV	MAINTENANCE CONTRACTS	COPIER	68886493	10/7/2018	10/19/2018	289.90
Total:						\$83,246.51
<hr/>						
E911						
AT&T MOBILITY	TELECOMMUNICATIONS	WIRELESS	287284406274X092620	9/26/2018	10/12/2018	2.00
BANK OF AMERICA	BLDGS EQUIP REP & MAINT	P-CARD	093018	9/30/2018	10/16/2018	304.02
BANK OF AMERICA	MAINTENANCE CONTRACTS	P-CARD	093018	9/30/2018	10/16/2018	20.00
BANK OF AMERICA	MAINTENANCE CONTRACTS	P-CARD	093018	9/30/2018	10/16/2018	25.00
BANK OF AMERICA	MAINTENANCE CONTRACTS	P-CARD	093018	9/30/2018	10/16/2018	204.00
CANON FINANCIAL SERVICES, INC.	LEASE/RENT	COPIER MONTHLY CHARGES	19235147	9/21/2018	10/5/2018	80.95
CANON FINANCIAL SERVICES, INC.	LEASE/RENT	COPIER MONTHLY CHARGES	19279789	10/13/2018	10/26/2018	80.95
CENTURYLINK	TELECOMMUNICATIONS	WIRELINE BILLING	310042302 091618	9/16/2018	10/5/2018	2,695.00
CENTURYLINK	TELECOMMUNICATIONS	E911	310214091 091918	9/19/2018	10/12/2018	144.21
CENTURYLINK	TELECOMMUNICATIONS	MONTHLY CHARGES	310042302 101018	10/10/2018	10/26/2018	2,702.00
COMCAST CORPORATION	TELECOMMUNICATIONS	MONTHLY CHARGES	0046933 090318	9/3/2018	10/5/2018	92.83
COMCAST CORPORATION	TELECOMMUNICATIONS	BUSINESS CABLE	0046933 100318	10/3/2018	10/12/2018	97.45
JOEL A. ZELINSKY	E911 NEW ROAD SIGNS	911 ADDRESS PLATES	3338	10/2/2018	10/19/2018	1,414.40
NWG SOLUTIONS, LLC.	IT SERVICES	MONTHLY BILLING FOR SEPEMBER	45312	9/28/2018	10/12/2018	1,275.00
NWG SOLUTIONS, LLC.	MAINTENANCE CONTRACTS	DATTO MONTHLY SERVICE/SUPPORT	45315	9/28/2018	10/12/2018	1,103.70

**County of Fluvanna
Accounts Payable List**

**From Date: 10/1/2018
To Date: 10/31/2018**



SPRINT	TELECOMMUNICATIONS	MONTHLY CHARGES	313771602-005	9/26/2018	10/12/2018	218.76
VERIZON	TELECOMMUNICATIONS	MONTHLY CHARGES	921953702-0001 1031	10/8/2018	10/26/2018	50.18
VIRGINIA BUSINESS SYSTEMS	LEASE/RENT	KONICA 364E	23452978	10/1/2018	10/26/2018	77.73
Total:						\$10,588.18
FIRE AND RESCUE SQUAD						
BANK OF AMERICA	FURNITURE & FIXTURES	P-CARD	093018	9/30/2018	10/16/2018	1,387.85
FLUVANNA COUNTY RESCUE SQUAD	FIRE & RESCUE ASSN	RESCUE SQUAD QUARTERLY	FR2-19	10/1/2018	10/5/2018	25,800.00
FLUVANNA COUNTY VOLUNTEER FIRE	FIRE & RESCUE ASSN	FCFD (QUARTERLY)	FF2-19	10/1/2018	10/5/2018	33,800.00
GOODMAN TRUCK & TRACTOR CO.	VEHICLES REP & MAINT	REPAIR ACCIDENT DAMAGE	123614b	6/26/2018	10/5/2018	336.69
LAKE MONTICELLO FIRE & RESCUE	FIRE & RESCUE ASSN	LM FIRE (QUARTERLY)/PUMPER 51	LM2-19	10/1/2018	10/5/2018	77,500.00
LAKE MONTICELLO FIRE & RESCUE	FIRE & RESCUE CAPITAL	LM FIRE (QUARTERLY)/PUMPER 51	LM2-19	10/1/2018	10/5/2018	55,000.00
VERIZON	TELECOMMUNICATIONS	MONTHLY CHARGES	721970783-00001 1019	10/19/2018	10/26/2018	560.14
Total:						\$194,384.68
FOREST WARDEN						
STATE FORESTER	FOREST FIRE SUPPRESSION	COUNTY FIRE SUPPRESSION	20174057	10/4/2018	10/12/2018	9,141.84
Total:						\$9,141.84
CORRECTION AND DETENTION						
COUNTY OF ALBEMARLE, VIRGINIA	CONFINEMENT - BRJDC	OCTOBER 2018	FY2019-00000211	10/1/2018	10/5/2018	14,002.50
Total:						\$14,002.50
BUILDING INSPECTIONS						
BANK OF AMERICA	OTHER OPERATING SUPPLIES	P-CARD	093018	9/30/2018	10/16/2018	(\$18.26)
FLUVANNA CO PUBLIC SCHOOLS	VEHICLE FUEL	KEY FOBS	092018-02	9/20/2018	10/5/2018	5.00
JAMES RIVER SOLUTIONS	VEHICLE FUEL	FUEL	100218	10/2/2018	10/12/2018	48.38
JOHN VAUGHAN	CONVENTION AND EDUCATION	TRAVEL REIMBURSEMENT	10/26/18	10/1/2018	10/26/2018	99.00
MANSFIELD OIL COMPANY OF	VEHICLE FUEL	FUEL 9/16/18- 9/30/18	SQLCD-449684	10/2/2018	10/5/2018	34.35
MANSFIELD OIL COMPANY OF	VEHICLE FUEL	FUELS INVOICE 10/01/18 - 10/15/18	SQLCD-452785	10/16/2018	10/19/2018	40.82
PITNEY BOWES PURCHASE PWR	POSTAL SERVICES	POSTAGE	01515654 101818	10/16/2018	10/26/2018	3.09
VERIZON	TELECOMMUNICATIONS	MONTHLY CHARGES	721970783-00001 1019	10/19/2018	10/26/2018	140.37
Total:						\$352.75
EMERGENCY MANAGEMENT						
CANON FINANCIAL SERVICES, INC.	LEASE/RENT	COPIER MONTHLY CHARGES	19235147	9/21/2018	10/5/2018	57.00
CANON FINANCIAL SERVICES, INC.	LEASE/RENT	COPIER MONTHLY CHARGES	19279789	10/13/2018	10/26/2018	57.00
CLEAR COMMUNICATIONS AND	PROFESSIONAL SERVICES	RADIOS & ACCESSORIES	117301	9/27/2018	10/26/2018	717.45
JAMES RIVER SOLUTIONS	VEHICLE FUEL	FUEL	100218	10/2/2018	10/12/2018	137.33

**County of Fluvanna
Accounts Payable List**

**From Date: 10/1/2018
To Date: 10/31/2018**



RECTOR & VISITORS OF THE VERIZON	CONTRACT SERVICES TELECOMMUNICATIONS	EMS COVERAGE SEPTEMBER 2018 MONTHLY CHARGES	UVAMTN 10/4/18 721970783-00001 1019	10/4/2018 10/19/2018	10/19/2018 10/26/2018	47,692.99 50.18
Total:						\$48,711.95
FACILITIES						
ALBEMARLE LOCK & SAFE, INC.	BLDGS EQUIP REP & MAINT	RESCUE SQUAD KEYPAD	77613	10/2/2018	10/19/2018	742.95
ALBEMARLE LOCK & SAFE, INC.	BLDGS EQUIP REP & MAINT	KEYS	78052	10/22/2018	10/26/2018	8.00
BANK OF AMERICA	BLDGS EQUIP REP & MAINT	P-CARD	093018	9/30/2018	10/16/2018	32.94
BANK OF AMERICA	BLDGS EQUIP REP & MAINT	P-CARD	093018	9/30/2018	10/16/2018	282.20
BANK OF AMERICA	OFFICE SUPPLIES	P-CARD	093018	9/30/2018	10/16/2018	47.28
BANK OF AMERICA	SUBSISTENCE & LODGING	P-CARD	093018	9/30/2018	10/16/2018	61.51
BANK OF AMERICA	VEHICLE/POWER EQUIP	P-CARD	093018	9/30/2018	10/16/2018	85.00
BANK OF AMERICA	VEHICLES REP & MAINT	P-CARD	093018	9/30/2018	10/16/2018	109.00
BARRETT TREE SERVICE, INC.	CONTRACT SERVICES	CUTTING TREES BEHIND LIBRARY	100418	10/4/2018	10/12/2018	2,850.00
BFPE INTERNATIONAL	BLDGS EQUIP REP & MAINT	PERFORMING ARTS CTR	2266616	10/17/2018	10/26/2018	190.00
BFPE INTERNATIONAL	BLDGS EQUIP REP & MAINT	COURTS BUILDING	2255456	9/24/2018	10/26/2018	1,120.00
BRAME SPECIALTY COMPANY, INC.	JANITORIAL SUPPLIES	CLEANING SUPPLIES	7345026	9/26/2018	10/12/2018	430.40
BRAME SPECIALTY COMPANY, INC.	JANITORIAL SUPPLIES	BOWL CLEANSE	7348439	10/5/2018	10/19/2018	32.52
BRAME SPECIALTY COMPANY, INC.	JANITORIAL SUPPLIES	TOWELS	7351544	10/18/2018	10/26/2018	164.18
BRAME SPECIALTY COMPANY, INC.	JANITORIAL SUPPLIES	VACUUM PARTS	7343754	10/11/2018	10/26/2018	419.23
BRAME SPECIALTY COMPANY, INC.	JANITORIAL SUPPLIES	EXTRACTOR CARPET ICE	7350527	10/1/2018	10/26/2018	1,585.76
BROWN MOTOR PARTS, INC.	GENERAL MATERIALS AND	INSPECTIONS/VEHICLE PARTS	94189	9/30/2018	10/19/2018	44.94
BROWN MOTOR PARTS, INC.	VEHICLE/POWER EQUIP	INSPECTIONS/VEHICLE PARTS	94189	9/30/2018	10/19/2018	126.37
BROWN MOTOR PARTS, INC.	VEHICLES REP & MAINT	INSPECTIONS/VEHICLE PARTS	94189	9/30/2018	10/19/2018	48.00
CAMPBELL EQUIPMENT, INC.	VEHICLES REP & MAINT	TRAILER TIRES	092818	9/28/2018	10/12/2018	169.98
CAMPBELL EQUIPMENT, INC.	VEHICLES REP & MAINT	TIRE REPAIR	100918	10/9/2018	10/26/2018	22.00
CII SERVICE	BLDGS EQUIP REP & MAINT	SOCIAL SERVICES WO#4289	43902	9/28/2018	10/19/2018	485.21
CII SERVICE	BLDGS EQUIP REP & MAINT	SOCIAL SERVICES WO#4278	43897	9/28/2018	10/19/2018	952.33
CII SERVICE	BLDGS EQUIP REP & MAINT	SOCIAL SERVICES	43896	9/28/2018	10/19/2018	1,109.89
CII SERVICE	BLDGS EQUIP REP & MAINT	OLD COURTHOUSE UNIT REPLACEMENT	43892	9/28/2018	10/19/2018	6,881.43
CII SERVICE	BLDGS EQUIP REP & MAINT	COMMUNITY CENTER	43964	9/30/2018	10/26/2018	587.08
CINTAS	LAUNDRY AND DRY CLEANING	DRY CLEANING	394249372	9/27/2018	10/5/2018	112.21
CINTAS	LAUNDRY AND DRY CLEANING	DRY CLEANING/MAT CLEANING	394251313	10/4/2018	10/12/2018	112.21
CINTAS	LAUNDRY AND DRY CLEANING	DRY CLEANING/MATS	394253230	10/11/2018	10/19/2018	105.99
CINTAS	LAUNDRY AND DRY CLEANING	DRY CLEANING & MAS	394255133	10/18/2018	10/26/2018	112.64
CINTAS	PROFESSIONAL SERVICES	DRY CLEANING/MAT CLEANING	394251313	10/4/2018	10/12/2018	4.63
CINTAS	PROFESSIONAL SERVICES	DRY CLEANING/MATS	394253230	10/11/2018	10/19/2018	4.63
CINTAS	PROFESSIONAL SERVICES	DRY CLEANING & MAS	394255133	10/18/2018	10/26/2018	4.63
COMMONWEALTH INTERIORS	BLDGS EQUIP REP & MAINT	PALMYRA RESCUE SQUAD FLOORING	2018-205	9/26/2018	10/12/2018	5,928.00

**County of Fluvanna
Accounts Payable List**

**From Date: 10/1/2018
To Date: 10/31/2018**



COMMONWEALTH INTERIORS	BLDGS EQUIP REP & MAINT	FLOORING FOR SPCA	2018-218	10/12/2018	10/26/2018	7,865.00
E.W. THOMAS	GENERAL MATERIALS AND	ICE/CLEANING SUPPLIES	100518	10/5/2018	10/12/2018	46.85
EPOXY SYSTEMS LLC	BLDGS EQUIP REP & MAINT	FLOORING FOR SPCA	8560	9/18/2018	10/19/2018	17,090.00
FLUVANNA ACE HARDWARE	BLDGS EQUIP REP & MAINT	HARDWARE SUPPLIES	093018	9/30/2018	10/19/2018	25.44
FLUVANNA ACE HARDWARE	GENERAL MATERIALS AND	HARDWARE SUPPLIES	093018	9/30/2018	10/19/2018	742.49
FLUVANNA CO PUBLIC SCHOOLS	VEHICLE FUEL	KEY FOBS	092018-02	9/20/2018	10/5/2018	5.00
GARY OSTEEEN PLUMBING	BLDGS EQUIP REP & MAINT	SOCIAL SERVICES 1ST FLOOR	092418	9/24/2018	10/5/2018	412.50
GARY OSTEEEN PLUMBING	BLDGS EQUIP REP & MAINT	SOCIAL SERVICES BLDG DOWNSTAIRS	092518	9/25/2018	10/5/2018	858.50
GARY OSTEEEN PLUMBING	BLDGS EQUIP REP & MAINT	PLEASANT GROVE BATHROOM	092618	9/26/2018	10/26/2018	5,815.90
GENSERV	BLDGS EQUIP REP & MAINT	RESCUE STATION 1	3025	10/21/2018	10/26/2018	285.00
JAMES RIVER SOLUTIONS	VEHICLE FUEL	FUEL	100218	10/2/2018	10/12/2018	1,486.42
JONES AUTOMOTIVE/ALL STAR AUTO	GENERAL MATERIALS AND	VEHICLE SUPPLIES	092918	9/29/2018	10/19/2018	1,031.71
JONES AUTOMOTIVE/ALL STAR AUTO	VEHICLE/POWER EQUIP	VEHICLE SUPPLIES	092918	9/29/2018	10/19/2018	225.89
JONES AUTOMOTIVE/ALL STAR AUTO	VEHICLES REP & MAINT	VEHICLE SUPPLIES	092918	9/29/2018	10/19/2018	350.37
KOREN DIVERSIFIED HOLDINGS LLC	VEHICLE/POWER EQUIP	PARTS	67947	9/17/2018	10/19/2018	435.32
KOREN DIVERSIFIED HOLDINGS LLC	VEHICLE/POWER EQUIP	PARTS	70063	10/22/2018	10/26/2018	39.89
KOREN DIVERSIFIED HOLDINGS LLC	VEHICLES REP & MAINT	FUEL CAP/TANK	67943	9/17/2018	10/19/2018	224.73
LOWE'S	BLDGS EQUIP REP & MAINT	SUPPLIES	092518	9/25/2018	10/12/2018	1,166.06
LOWE'S	GENERAL MATERIALS AND	SUPPLIES	092518	9/25/2018	10/12/2018	1,132.36
M & N INDUSTRIES, INC.	BLDGS EQUIP REP & MAINT	RAIL FOR LANDFILL	7161	9/21/2018	10/12/2018	935.00
M & N INDUSTRIES, INC.	BLDGS EQUIP REP & MAINT	FLOOR REPAIR	7169	10/9/2018	10/26/2018	1,619.00
MAC'S SERVICE CENTER	BLDGS EQUIP REP & MAINT	STATE INSPECTION	0037438	10/5/2018	10/12/2018	16.00
MANSFIELD OIL COMPANY OF	VEHICLE FUEL	FUEL 9/16/18- 9/30/18	SQLCD-449684	10/2/2018	10/5/2018	72.01
MJC DESIGNS, LLC.	BLDGS EQUIP REP & MAINT	SIGN INSTALLATION REPAIR	2985	10/4/2018	10/12/2018	125.00
MSC INDUSTRIAL SUPPLY CO	GENERAL MATERIALS AND	CLEANING SUPPLIES	C21299350	10/9/2018	10/26/2018	251.02
MSC INDUSTRIAL SUPPLY CO	VEHICLE/POWER EQUIP	HARDWARE	22945970	10/17/2018	10/26/2018	418.76
RAFALY ELECTRICAL CONTRACTORS,	BLDGS EQUIP REP & MAINT	PLEASANT GROVE MUSEUM INSTALL	8021	9/26/2018	10/12/2018	4,183.00
RAFALY ELECTRICAL CONTRACTORS,	BLDGS EQUIP REP & MAINT	COURTHOUSE REPAIRS TO LIGHTS	8044	9/28/2018	10/19/2018	288.00
RAFALY ELECTRICAL CONTRACTORS,	BLDGS EQUIP REP & MAINT	SHERIFF OFFICE	8090	10/18/2018	10/26/2018	115.00
RAFALY ELECTRICAL CONTRACTORS,	BLDGS EQUIP REP & MAINT	ADMIN BUILDING REPLACE LIGHT	8081	10/18/2018	10/26/2018	443.00
REXEL, INC.	BLDGS EQUIP REP & MAINT	ELECTRICAL SUPPLIES	S122512794.001	9/12/2018	10/5/2018	178.27
RUHLMAN'S HAULING	BLDGS EQUIP REP & MAINT	PLEASANT GROVE HAUL	101118	10/11/2018	10/26/2018	412.88
STAPLES CONTRACT & COMMERCIAL,	OFFICE SUPPLIES	OFFICE SUPPLIES	8051666987	10/6/2018	10/19/2018	54.12
THE HARBOR SALES COMPANY INC	GENERAL MATERIALS AND	CLEANING SUPPLIES	2329417	10/15/2018	10/26/2018	171.40
THE SUPPLY ROOM	OFFICE SUPPLIES	OFFICE SUPPLIES	3441735-0	9/19/2018	10/5/2018	67.66
VERIZON	TELECOMMUNICATIONS	MONTHLY CHARGES	721970783-00001 1019	10/19/2018	10/26/2018	535.14
W.W. GRAINGER INC	BLDGS EQUIP REP & MAINT	SHELVING	9936014175	10/16/2018	10/26/2018	1,615.00
WINCHESTER EQUIPMENT COMPANY	VEHICLE/POWER EQUIP	TRACK LOADER REPAIR	S11909	10/19/2018	10/26/2018	1,217.47
Total:						\$76,930.30

**County of Fluvanna
Accounts Payable List**

**From Date: 10/1/2018
To Date: 10/31/2018**



GENERAL SERVICES

AQUA VIRGINIA, INC.	WATER SERVICES	213 MAIN ST	7970740556855 100418	10/4/2018	10/19/2018	20.61
AQUA VIRGINIA, INC.	WATER SERVICES	181 MAIN ST	15301850550900 10418	10/4/2018	10/19/2018	23.60
AQUA VIRGINIA, INC.	WATER SERVICES	197 MAIN ST	7929310552932 100418	10/4/2018	10/19/2018	30.34
AQUA VIRGINIA, INC.	WATER SERVICES	197 MAIN ST	7929300552931 100418	10/4/2018	10/19/2018	34.08
AQUA VIRGINIA, INC.	WATER SERVICES	132 MAIN ST	7800100540828	10/4/2018	10/19/2018	88.49
CENTRAL VA ELECTRIC COOP	ELECTRICAL SERVICES	THOMAS JEFFERSON PKWY	105221-009 091718	9/17/2018	10/5/2018	30.39
CENTRAL VA ELECTRIC COOP	ELECTRICAL SERVICES	271 PLEASANT GROVE DR	105221-008 091718	9/17/2018	10/5/2018	31.67
CENTRAL VA ELECTRIC COOP	ELECTRICAL SERVICES	THOMAS JEFFERSON PKWY	105221-002 091718	9/17/2018	10/5/2018	36.94
CENTRAL VA ELECTRIC COOP	ELECTRICAL SERVICES	COMPETITION PARK RD	105221-004 091718	9/17/2018	10/5/2018	48.76
CENTRAL VA ELECTRIC COOP	ELECTRICAL SERVICES	PLEASANT GROVE DR	105221-006 091718	9/17/2018	10/5/2018	67.93
CENTRAL VA ELECTRIC COOP	ELECTRICAL SERVICES	271 PLEASANT GROVE DR	105221-007 091718	9/17/2018	10/5/2018	132.78
CENTRAL VA ELECTRIC COOP	ELECTRICAL SERVICES	THOMAS JEFFERSON PARKWAY	105221-003 091718	9/17/2018	10/5/2018	215.93
CENTRAL VA ELECTRIC COOP	ELECTRICAL SERVICES	271 PLEASANT GROVE DR	275904-011 091718	9/17/2018	10/12/2018	32.71
CENTRAL VA ELECTRIC COOP	ELECTRICAL SERVICES	W RIVER RD	275904-008 091718	9/17/2018	10/12/2018	42.73
CENTRAL VA ELECTRIC COOP	ELECTRICAL SERVICES	271 PLEASANT GROVE DR	275904-006 091718	9/17/2018	10/12/2018	52.35
CENTRAL VA ELECTRIC COOP	ELECTRICAL SERVICES	11206 W RIVER RD	275904-002 091718	9/17/2018	10/12/2018	155.58
CENTRAL VA ELECTRIC COOP	ELECTRICAL SERVICES	2977 W RIVER RD	275904-010 091718	9/17/2018	10/12/2018	170.66
CENTRAL VA ELECTRIC COOP	ELECTRICAL SERVICES	271 PLEASANT GROVE DR	275904-004 091718	9/17/2018	10/12/2018	317.08
CENTRAL VA ELECTRIC COOP	ELECTRICAL SERVICES	E-911 TOWER-COMMONS BLVD	275904-009 091718	9/17/2018	10/12/2018	373.09
CENTRAL VA ELECTRIC COOP	ELECTRICAL SERVICES	51 KENTS STORE RD	275907-002 100318	10/3/2018	10/19/2018	468.97
CENTRAL VA ELECTRIC COOP	ELECTRICAL SERVICES	LIBRARY ELECTRIC	275906-001 092818	9/28/2018	10/19/2018	1,445.39
CENTRAL VA ELECTRIC COOP	ELECTRICAL SERVICES	SHERIFFS ELECTRIC	85473-002 092818	9/28/2018	10/19/2018	2,417.11
CENTRAL VA ELECTRIC COOP	ELECTRICAL SERVICES	W RIVER ROAD	275904-008 101718	10/17/2018	10/26/2018	0.45
CENTRAL VA ELECTRIC COOP	ELECTRICAL SERVICES	271 PLEASANT GROVE DR	275904-006 101718	10/17/2018	10/26/2018	0.78
CENTRAL VA ELECTRIC COOP	ELECTRICAL SERVICES	271 PLEASANT GROVE DR	275904-011 101718	10/17/2018	10/26/2018	0.99
CENTRAL VA ELECTRIC COOP	ELECTRICAL SERVICES	11206 W RIVER RD	275904-002 101718	10/17/2018	10/26/2018	2.33
CENTRAL VA ELECTRIC COOP	ELECTRICAL SERVICES	2977 W RIVER ROAD	275904-010 101718	10/17/2018	10/26/2018	2.48
CENTRAL VA ELECTRIC COOP	ELECTRICAL SERVICES	271 PLEASANT GROVE DR	275904-004 101718	10/17/2018	10/26/2018	4.75
CENTRAL VA ELECTRIC COOP	ELECTRICAL SERVICES	E-911 TOWER-COMMONS BLVD	275904-009 101718	10/17/2018	10/26/2018	5.48
CENTRAL VA ELECTRIC COOP	ELECTRICAL SERVICES	PLEASANT GROVE DR	105221-006 101718	10/17/2018	10/26/2018	28.39
CENTRAL VA ELECTRIC COOP	ELECTRICAL SERVICES	PARKS & REC	105221-007 101718	10/17/2018	10/26/2018	30.39
CENTRAL VA ELECTRIC COOP	ELECTRICAL SERVICES	PAKRS & REC	105221-009 101718	10/17/2018	10/26/2018	30.39
CENTRAL VA ELECTRIC COOP	ELECTRICAL SERVICES	271 PLEASANT GROVE DR	275904-011 101718	10/17/2018	10/26/2018	30.52
CENTRAL VA ELECTRIC COOP	ELECTRICAL SERVICES	THOMAS JEFFERSON PKWY	105221-002 101718	10/17/2018	10/26/2018	30.77
CENTRAL VA ELECTRIC COOP	ELECTRICAL SERVICES	271 PLEASANT GROVE DR	105221-008 10/17/18	10/17/2018	10/26/2018	31.41
CENTRAL VA ELECTRIC COOP	ELECTRICAL SERVICES	THOMAS JEFFERSON PKWY	105221-003 101718	10/17/2018	10/26/2018	32.71
CENTRAL VA ELECTRIC COOP	ELECTRICAL SERVICES	718 THOMAS JEFFERSON PKWY	85473003 101718	10/17/2018	10/26/2018	35.26



County of Fluvanna Accounts Payable List

From Date: 10/1/2018
To Date: 10/31/2018

CENTRAL VA ELECTRIC COOP	ELECTRICAL SERVICES	271 PLEASANT GROVE DR	275904-006 101718	10/17/2018	10/26/2018	37.10
CENTRAL VA ELECTRIC COOP	ELECTRICAL SERVICES	W RIVER ROAD	275904-008 101718	10/17/2018	10/26/2018	43.18
CENTRAL VA ELECTRIC COOP	ELECTRICAL SERVICES	COMPETITION PARK RD	15221-004 101718	10/17/2018	10/26/2018	54.64
CENTRAL VA ELECTRIC COOP	ELECTRICAL SERVICES	11206 W RIVER RD	275904-002 101718	10/17/2018	10/26/2018	136.16
CENTRAL VA ELECTRIC COOP	ELECTRICAL SERVICES	2977 W RIVER ROAD	275904-010 101718	10/17/2018	10/26/2018	172.42
CENTRAL VA ELECTRIC COOP	ELECTRICAL SERVICES	11206 W RIVER RD	85473005 101718	10/17/2018	10/26/2018	227.52
CENTRAL VA ELECTRIC COOP	ELECTRICAL SERVICES	563 WIMLINGTON RD	85473006 101718	10/17/2018	10/26/2018	230.07
CENTRAL VA ELECTRIC COOP	ELECTRICAL SERVICES	271 PLEASANT GROVE DR	275904-004 101718	10/17/2018	10/26/2018	267.67
CENTRAL VA ELECTRIC COOP	ELECTRICAL SERVICES	E-911 TOWER-COMMONS BLVD	275904-009 101718	10/17/2018	10/26/2018	381.33
CENTRAL VA ELECTRIC COOP	STREET LIGHTS	THOMAS JEFFERSON PKWY	85473-001 101718	10/17/2018	10/26/2018	73.70
CENTURYLINK 589-8525	TELECOMMUNICATIONS	PAY PHONE	A416339	9/25/2018	10/19/2018	50.00
CENTURYLINK	TELECOMMUNICATIONS	PUBLIC WORKS	309428096 091618	9/16/2018	10/5/2018	43.31
CENTURYLINK	TELECOMMUNICATIONS	PUBLIC WORKS	309697981 091618	9/16/2018	10/5/2018	52.21
CENTURYLINK	TELECOMMUNICATIONS	CIRCUIT COURT	310338742 091718	9/16/2018	10/5/2018	53.94
CENTURYLINK	TELECOMMUNICATIONS	PERFORMING ARTS	309898636 091718	9/16/2018	10/5/2018	106.65
CENTURYLINK	TELECOMMUNICATIONS	RESCUE SQUAD	310110229 091618	9/16/2018	10/5/2018	185.33
CENTURYLINK	TELECOMMUNICATIONS	LOCAL LONG DISTANCE	309762613 091618	9/16/2018	10/5/2018	219.99
CENTURYLINK	TELECOMMUNICATIONS	PUBLIC WORKS	309363296 091718	9/16/2018	10/5/2018	544.96
CENTURYLINK	TELECOMMUNICATIONS	LOCAL LONG DISTANCE	309762613 091618	9/16/2018	10/5/2018	674.94
CII SERVICE	MAINTENANCE CONTRACTS	CONTRACT	43969	10/15/2018	10/26/2018	3,756.00
CINTAS	MAINTENANCE CONTRACTS	FIRST AID SUPPLIES	8403865406	10/19/2018	10/26/2018	64.21
CINTAS	MAINTENANCE CONTRACTS	FIRST AID SUPPLIES	5011984246	10/15/2018	10/26/2018	198.88
CINTAS	MAINTENANCE CONTRACTS	FIRST AID SUPPLIES	5011969946	10/19/2018	10/26/2018	204.80
DOMINION VIRGINIA POWER	ELECTRICAL SERVICES	51 COURT SQ BLDG 5	1114097502 092618	9/26/2018	10/12/2018	7.73
DOMINION VIRGINIA POWER	ELECTRICAL SERVICES	14591 JAMES MADISON HWY CELL	5699060132 092618	9/26/2018	10/12/2018	8.06
DOMINION VIRGINIA POWER	ELECTRICAL SERVICES	RT 1001 OLD STONE JAIL	1424085007 092418	9/24/2018	10/12/2018	10.38
DOMINION VIRGINIA POWER	ELECTRICAL SERVICES	222 MAIN ST HOUSING OFFICE	11340800009 092618	9/26/2018	10/12/2018	10.69
DOMINION VIRGINIA POWER	ELECTRICAL SERVICES	196 MAIN ST CSA OFFICE	11240900000 092618	9/26/2018	10/12/2018	12.67
DOMINION VIRGINIA POWER	ELECTRICAL SERVICES	8952 JAMES MADISON HWY LG BALLFIELD	3023889169 092418	9/24/2018	10/12/2018	23.49
DOMINION VIRGINIA POWER	ELECTRICAL SERVICES	8880 JAMES MADISON HWY	7048771633 092618	9/26/2018	10/12/2018	39.41
DOMINION VIRGINIA POWER	ELECTRICAL SERVICES	LG BALLFIELD CONCESSION	0692200942 092618	9/26/2018	10/12/2018	78.40
DOMINION VIRGINIA POWER	ELECTRICAL SERVICES	8878 JAMES MADISON HWY SM	0274195007 092618	9/26/2018	10/12/2018	78.50
DOMINION VIRGINIA POWER	ELECTRICAL SERVICES	211 MAIN ST REGISTRATR'S OFFICE	1284152509 092618	9/26/2018	10/12/2018	116.72
DOMINION VIRGINIA POWER	ELECTRICAL SERVICES	1038 BREMO RD CELL TOWER	6260822157 092618	9/26/2018	10/12/2018	147.59
DOMINION VIRGINIA POWER	ELECTRICAL SERVICES	197 MAIN ST PUBLIC WORKS	1304130006 092618	9/26/2018	10/12/2018	150.43
DOMINION VIRGINIA POWER	ELECTRICAL SERVICES	181 MAIN ST	6274752663 092618	9/26/2018	10/12/2018	184.24
DOMINION VIRGINIA POWER	ELECTRICAL SERVICES	8952 JAMES MADISON HWY PERFORMING	4144237502 092418	9/24/2018	10/12/2018	209.36
DOMINION VIRGINIA POWER	ELECTRICAL SERVICES	FORK UNION FIRE STATION	8866300000 092618	9/26/2018	10/12/2018	215.53
DOMINION VIRGINIA POWER	ELECTRICAL SERVICES	8878 JAMES MADISON HWY GYMNASIUM	0084297506 092418	9/24/2018	10/12/2018	266.63



County of Fluvanna Accounts Payable List

From Date: 10/1/2018
To Date: 10/31/2018

DOMINION VIRGINIA POWER	ELECTRICAL SERVICES	35 COURT SQ HISTORIC COURTHOUSE	1144090006 092418	9/24/2018	10/12/2018	355.74
DOMINION VIRGINIA POWER	ELECTRICAL SERVICES	90 RESCUE LN	4894115007 092418	9/24/2018	10/12/2018	365.75
DOMINION VIRGINIA POWER	ELECTRICAL SERVICES	34 PALMYRA WAY TREASURERS OFFICE	1024205005 092418	9/24/2018	10/12/2018	439.73
DOMINION VIRGINIA POWER	ELECTRICAL SERVICES	14567 JAMES MADISON HWY FIRE	1005898992	9/24/2018	10/12/2018	462.82
DOMINION VIRGINIA POWER	ELECTRICAL SERVICES	5753 JAMES MADISON HWY FORK UNION	4834680458 092518	9/25/2018	10/12/2018	482.93
DOMINION VIRGINIA POWER	ELECTRICAL SERVICES	8880 JAMES MADISON HWY	2554330007 092718	9/27/2018	10/12/2018	688.29
DOMINION VIRGINIA POWER	ELECTRICAL SERVICES	COMMUNITY CENTER	4331888158 92518	9/25/2018	10/12/2018	722.81
DOMINION VIRGINIA POWER	ELECTRICAL SERVICES	8952 JAMES MADISON HWY	0074032509 092418	9/24/2018	10/12/2018	1,073.65
DOMINION VIRGINIA POWER	ELECTRICAL SERVICES	72 MAIN ST ADMIN BLDG	1404067504 092418	9/24/2018	10/12/2018	1,098.40
DOMINION VIRGINIA POWER	ELECTRICAL SERVICES	132 MAIN ST COURTS BLDY	8895892548 092418	9/24/2018	10/12/2018	2,665.77
DOMINION VIRGINIA POWER	STREET LIGHTS	BESIDE POST OFFICE	7080078962 092618	9/26/2018	10/12/2018	60.21
DOMINION VIRGINIA POWER	STREET LIGHTS	NEAR MASONIC LODGE	9609027314 092618	9/26/2018	10/12/2018	70.47
DOMINION VIRGINIA POWER	STREET LIGHTS	COLUMBIA STREETLIGHTS	4210122349 092618	9/26/2018	10/12/2018	207.82
DOMINION VIRGINIA POWER	STREET LIGHTS	PALMYRA VILLAGE STREET LIGHTING	3595578927 092618	9/26/2018	10/12/2018	485.32
INTRASTATE PEST	MAINTENANCE CONTRACTS	PALMYRA FIRE STATION	1010686	9/1/2018	10/5/2018	38.00
INTRASTATE PEST	MAINTENANCE CONTRACTS	FORK UNION COMMUNITY CENTER	1008819/1016205	9/1/2018	10/5/2018	56.00
INTRASTATE PEST	MAINTENANCE CONTRACTS	PLEASANT GROVE	1008836/1016224	9/1/2018	10/5/2018	64.00
INTRASTATE PEST	MAINTENANCE CONTRACTS	OLD STONE JAIL	1010744	9/1/2018	10/5/2018	85.00
INTRASTATE PEST	MAINTENANCE CONTRACTS	KENTS STORE FIRE STATION	1004748/1010687	9/28/2018	10/12/2018	76.00
INTRASTATE PEST	MAINTENANCE CONTRACTS	CARYSBROOK CONCESSIONS	4261-62, 10190-91	9/28/2018	10/12/2018	80.00
INTRASTATE PEST	MAINTENANCE CONTRACTS	PLEASANT GROVE CONCESSIONS	4263-64, 10192-93	9/28/2018	10/12/2018	80.00
INTRASTATE PEST	MAINTENANCE CONTRACTS	PALMYRA RESCUE	4623/10530/17627	9/28/2018	10/12/2018	102.00
INTRASTATE PEST	MAINTENANCE CONTRACTS	CARYSBROOK/PUBLIC SAFETY BLDG	1002753/1003449	9/28/2018	10/12/2018	367.00
INTRASTATE PEST	MAINTENANCE CONTRACTS	HISTORIC COURT HOUSE/PALMYRA	1002746/1002761	9/28/2018	10/12/2018	490.00
INTRASTATE PEST	MAINTENANCE CONTRACTS	FORK UNION COMMUNITY CTR	1021579	10/10/2018	10/26/2018	28.00
INTRASTATE PEST	MAINTENANCE CONTRACTS	PLEASANT GROVE	1021596	10/10/2018	10/26/2018	32.00
INTRASTATE PEST	MAINTENANCE CONTRACTS	KENTS STORE FIRE STATION	1017695	10/10/2018	10/26/2018	38.00
INTRASTATE PEST	MAINTENANCE CONTRACTS	CARYSBROOK CONCESSIONS	1017438,1017439	10/10/2018	10/26/2018	40.00
INTRASTATE PEST	MAINTENANCE CONTRACTS	PLEASANT GROVE CONCESSIONS	1017440,1017441	10/10/2018	10/26/2018	40.00
INTRASTATE PEST	MAINTENANCE CONTRACTS	FORK UNION FIRE STATION	1004746,1010685,7693	10/10/2018	10/26/2018	114.00
REPUBLIC SERVICES #410	MAINTENANCE CONTRACTS	SEPTEMBER DUMPSTER PICK UP	0410-000662658	9/30/2018	10/19/2018	1,769.71
SHRED-IT USA LLC	LEASE/RENT	SHREDDING SERVICE	8125760002	10/7/2018	10/12/2018	150.00
THE BLOSSMAN COMPANIES, INC.	HEATING SERVICES	PALMYRA FIRE HOUSE FUEL TANK	4925124	10/2/2018	10/12/2018	21.00
THE BLOSSMAN COMPANIES, INC.	HEATING SERVICES	FORK UNION FIRE - PROPANE	4987777	10/12/2018	10/26/2018	196.86
TREASURER, FLUVANNA CO	SEWER SERVICES	FLUCO REGISTRAR	39106	10/15/2018	10/26/2018	13.06
TREASURER, FLUVANNA CO	SEWER SERVICES	COMMONWEALTH ATTORNEY	39103	10/15/2018	10/26/2018	14.59
TREASURER, FLUVANNA CO	SEWER SERVICES	PUBLIC WORKS	39104	10/15/2018	10/26/2018	23.01
TREASURER, FLUVANNA CO	SEWER SERVICES	PUBLIC SAFETY BUILDING	39114	10/15/2018	10/26/2018	25.30
TREASURER, FLUVANNA CO	SEWER SERVICES	LIBRARY	39115	10/15/2018	10/26/2018	25.30

County of Fluvanna Accounts Payable List

From Date: 10/1/2018
To Date: 10/31/2018



TREASURER, FLUVANNA CO	SEWER SERVICES	ADMIN BUILDING	39097	10/15/2018	10/26/2018	30.66
TREASURER, FLUVANNA CO	SEWER SERVICES	COURTS BUILDING	39096	10/15/2018	10/26/2018	32.95
TREASURER, FLUVANNA CO	SEWER SERVICES	PLEASANT GROVE HOUSE	39124	10/15/2018	10/26/2018	32.95
TREASURER, FLUVANNA CO	WATER SERVICES	FLUVANNA GYM	39286	10/15/2018	10/26/2018	21.00
TREASURER, FLUVANNA CO	WATER SERVICES	CARYSBROOK SOFTBALL FIELD	39460	10/12/2018	10/26/2018	21.00
TREASURER, FLUVANNA CO	WATER SERVICES	CARYSBROOK BASEBALL FIELD	39461	10/15/2018	10/26/2018	21.00
TREASURER, FLUVANNA CO	WATER SERVICES	FLUVANNA COUNTY FIRE HOUSE	39462	10/15/2018	10/26/2018	21.00
TREASURER, FLUVANNA CO	WATER SERVICES	CARYSBROOK	39287	10/15/2018	10/26/2018	83.70
TREASURER, FLUVANNA CO	WATER SERVICES	FORK UNION	39411	10/15/2018	10/26/2018	121.00
W & H RESOURCES, INC	MAINTENANCE CONTRACTS	MAINTENANCE BILLING FOR OCTOBER	17102	10/1/2018	10/19/2018	1,725.00
Total:						\$31,101.93
PUBLIC WORKS						
BANK OF AMERICA	OFFICE SUPPLIES	P-CARD	093018	9/30/2018	10/16/2018	27.90
CANON FINANCIAL SERVICES, INC.	LEASE/RENT	COPIER MONTHLY CHARGES	19235147	9/21/2018	10/5/2018	220.00
CANON FINANCIAL SERVICES, INC.	LEASE/RENT	COPIER MONTHLY CHARGES	19279789	10/13/2018	10/26/2018	220.00
VERIZON	TELECOMMUNICATIONS	MONTHLY CHARGES	721970783-00001 1019	10/19/2018	10/26/2018	100.36
VIRGINIA BUSINESS SYSTEMS	LEASE/RENT	20190028-00 HP DESINGJET T730	23439919	9/27/2018	10/12/2018	93.04
VIRGINIA BUSINESS SYSTEMS	LEASE/RENT	KONICA BIZHUB C364	23452977	10/1/2018	10/19/2018	239.29
Total:						\$900.59
CONVENIENCE CENTER						
CAMPBELL EQUIPMENT, INC.	CONTRACT SERVICES	TIRE DISPOSAL	092818B	9/28/2018	10/12/2018	170.00
CAROLINA SOFTWARE	BLDGS EQUIP REP & MAINT	WASTEWORX SOFTWARE SUPPORT	100118	10/1/2018	10/19/2018	250.00
CENTURYLINK	TELECOMMUNICATIONS	LANDFILL SCALES	310392717 091718	9/16/2018	10/5/2018	69.80
HERITAGE CRYSTALCLEAN, LLC	BLDGS EQUIP REP & MAINT	TRIP FEE - USED OIL SERVICE	15322134	9/20/2018	10/5/2018	75.00
JAMES RIVER SOLUTIONS	VEHICLE FUEL	FUEL	100218	10/2/2018	10/12/2018	113.41
MO-JOHNS, INC.	LEASE/RENT	COUNTY LANDFILL	112744	9/24/2018	10/12/2018	60.00
STAPLES CONTRACT & COMMERCIAL,	OFFICE SUPPLIES	OFFICE SUPPLIES	8051666987	10/6/2018	10/19/2018	159.75
VERIZON	TELECOMMUNICATIONS	MONTHLY CHARGES	721970783-00001 1019	10/19/2018	10/26/2018	62.34
Total:						\$960.30
PUBLIC UTILITIES						
ANDERSON TIRE COMPANY	VEHICLES REP & MAINT	STATE INSPECTIONS	R060034 092918	9/29/2018	10/19/2018	48.00
ARTHURS SEPTIC SERVICE	CONTRACT SERVICES	PUMP & HAUL FROM CENTRAL	101218	10/12/2018	10/26/2018	370.00
BANK OF AMERICA	DUES OR ASSOCIATION	P-CARD	093018	9/30/2018	10/16/2018	75.00
BANK OF AMERICA	DUES OR ASSOCIATION	P-CARD	093018	9/30/2018	10/16/2018	304.00
BANK OF AMERICA	DUES OR ASSOCIATION	P-CARD	093018	9/30/2018	10/16/2018	330.00
BANK OF AMERICA	VEHICLE/POWER EQUIP	P-CARD	093018	9/30/2018	10/16/2018	36.94

**County of Fluvanna
Accounts Payable List**
**From Date: 10/1/2018
To Date: 10/31/2018**

BANK OF AMERICA	VEHICLES REP & MAINT	P-CARD	093018	9/30/2018	10/16/2018	129.57
CENTRAL VA ELECTRIC COOP	ELECTRICAL SERVICES	THOMAS JEFFERSON PKWY	203061-001 091718	9/17/2018	10/5/2018	29.59
CENTRAL VA ELECTRIC COOP	ELECTRICAL SERVICES	COMPETITION PARK	105221-001 091718	9/17/2018	10/5/2018	184.69
CENTRAL VA ELECTRIC COOP	ELECTRICAL SERVICES	THOMAS JEFFERSON PKWY	203061001 101718	10/17/2018	10/26/2018	30.02
CENTRAL VA ELECTRIC COOP	ELECTRICAL SERVICES	COMPETITION PARK RD	105221-001 101718	10/17/2018	10/26/2018	186.87
CENTURYLINK	TELECOMMUNICATIONS	SANITARY DISTRICT	309719161 091618	9/16/2018	10/5/2018	197.90
CENTURYLINK	TELECOMMUNICATIONS	PALMYRA WASTEWATER TREATMENT	310089744 091918	9/19/2018	10/12/2018	47.47
CENTURYLINK	TELECOMMUNICATIONS	PALMYRA WASTEWATER TREATMENT	309433290 091918	9/19/2018	10/12/2018	68.88
CINTAS	LAUNDRY AND DRY CLEANING	DRY CLEANING	394249369	9/27/2018	10/5/2018	39.62
CINTAS	LAUNDRY AND DRY CLEANING	DRY CLEANING	394251311	10/4/2018	10/12/2018	39.62
CINTAS	LAUNDRY AND DRY CLEANING	DRY CLEANING	394253227	10/11/2018	10/19/2018	39.62
CINTAS	LAUNDRY AND DRY CLEANING	DRY CLEANING	394255129	10/18/2018	10/26/2018	39.62
DOMINION VIRGINIA POWER	ELECTRICAL SERVICES	RT 1001 PUMP HOUSE	4501632147 092418	9/24/2018	10/12/2018	58.04
E.W. THOMAS	CHEMICAL SUPPLIES	ICE/CLEANING SUPPLIES	100518	10/5/2018	10/12/2018	57.58
ENVIROCOMPLIANCE LAB	OUTSIDE ANALYTICAL	WATER TESTING PALMYRA	R8732656	8/6/2018	10/19/2018	60.00
ENVIROCOMPLIANCE LAB	OUTSIDE ANALYTICAL	WATER TESTING CENTRAL	R8732654	8/6/2018	10/19/2018	90.00
ENVIROCOMPLIANCE LAB	OUTSIDE ANALYTICAL	WATER TESTING CARYSBROOK	R8732655	8/6/2018	10/19/2018	180.00
INBODEN ENVIRONMENTAL	OUTSIDE ANALYTICAL	WASTEWATER MONITORING CENTRAL	65739	10/3/2018	10/19/2018	300.00
INBODEN ENVIRONMENTAL	OUTSIDE ANALYTICAL	WASTEWATER MONITORING	65740	10/3/2018	10/19/2018	300.00
INBODEN ENVIRONMENTAL	OUTSIDE ANALYTICAL	WASTEWATER MONITORING	65738	10/3/2018	10/19/2018	400.00
INBODEN ENVIRONMENTAL	OUTSIDE ANALYTICAL	WASTEWATER MONITORING PALMYRA	65816	10/11/2018	10/26/2018	147.00
INBODEN ENVIRONMENTAL	OUTSIDE ANALYTICAL	WASTEWATER MONITORING	65817	10/11/2018	10/26/2018	147.00
INBODEN ENVIRONMENTAL	OUTSIDE ANALYTICAL	WASTEWATER TESTING CENTRAL	65818	10/11/2018	10/26/2018	177.00
JAMES RIVER SOLUTIONS	VEHICLE FUEL	FUEL	100218	10/2/2018	10/12/2018	486.24
JONES AUTOMOTIVE/ALL STAR AUTO	VEHICLE/POWER EQUIP	VEHICLE SUPPLIES	599201	9/29/2018	10/12/2018	608.20
LOWE'S	GENERAL MATERIALS AND	SUPPLIES	092518	9/25/2018	10/12/2018	595.92
MO-JOHNS, INC.	PURCHASE OF SERVICES	WASTE WATER	112745	9/24/2018	10/12/2018	60.00
PITNEY BOWES PURCHASE PWR	POSTAL SERVICES	POSTAGE	01515654 101818	10/16/2018	10/26/2018	(\$0.01)
PITNEY BOWES PURCHASE PWR	POSTAL SERVICES	POSTAGE	01515654 101818	10/16/2018	10/26/2018	286.79
UNIVAR USA, INC.	CHEMICAL SUPPLIES	INDUSTRIAL CHEMICALS	R1744834	10/3/2018	10/12/2018	1,487.03
VERIZON BUSINESS/MCI COMM	TELECOMMUNICATIONS	MONTHLY CHARGES	05619915	9/25/2018	10/5/2018	19.06
VERIZON	TELECOMMUNICATIONS	MONTHLY CHARGES	721970783-00001 1019	10/19/2018	10/26/2018	335.47
Total:						\$7,992.73
<hr/>						
HEALTH						
CENTURYLINK	TELECOMMUNICATIONS	LOCAL LONG DISTANCE	309762613 091618	9/16/2018	10/5/2018	151.86
Total:						\$151.86
<hr/>						
VJCCCA						

**County of Fluvanna
Accounts Payable List**

**From Date: 10/1/2018
To Date: 10/31/2018**



REDEMPTION YOUTH MENTORING	PROFESSIONAL SERVICES	MENTORING	093018	9/30/2018	10/19/2018	930.00
Total:						\$930.00
CSA						
BANK OF AMERICA	CONVENTION AND EDUCATION	P-CARD	093018	9/30/2018	10/16/2018	12.00
BANK OF AMERICA	SUBSISTENCE & LODGING	P-CARD	093018	9/30/2018	10/16/2018	9.92
CANON FINANCIAL SERVICES, INC.	LEASE/RENT	COPIER MONTHLY CHARGES	19235147	9/21/2018	10/5/2018	57.00
CANON FINANCIAL SERVICES, INC.	LEASE/RENT	COPIER MONTHLY CHARGES	19279789	10/13/2018	10/26/2018	57.00
PITNEY BOWES PURCHASE PWR	POSTAL SERVICES	POSTAGE	01515654 101818	10/16/2018	10/26/2018	77.80
STAPLES CONTRACT & COMMERCIAL,	OFFICE SUPPLIES	OFFICE SUPPLIES	8051666987	10/6/2018	10/19/2018	22.18
THE SUPPLY ROOM	OFFICE SUPPLIES	CLIPBOARDS/INK	3464931-0	10/10/2018	10/19/2018	7.76
Total:						\$243.66
CSA PURCHASE OF SERVICES						
ANDRE KEY	COMM SVCS		P08919724598	8/31/2018	10/19/2018	192.50
ANDRE KEY	COMM SVCS		P08919724200	8/31/2018	10/19/2018	385.00
ANDRE KEY	COMM SVCS		P08919724499	8/31/2018	10/19/2018	385.00
ANDRE KEY	COMM SVCS		P09919724501	9/30/2018	10/19/2018	385.00
ANDRE KEY	COMM SVCS		P09919724202	9/30/2018	10/19/2018	577.50
ANDRE KEY	COMM SVCS		P09919724403	9/30/2018	10/19/2018	770.00
ANDRE KEY	FF4E-COMM SVCS		P07919567534	7/31/2018	10/5/2018	550.00
ANDRE KEY	FF4E-COMM SVCS		P07919568132	7/31/2018	10/5/2018	550.00
ANDRE KEY	FF4E-COMM SVCS		P07919568633	7/31/2018	10/5/2018	550.00
ANDRE KEY	FF4E-COMM SVCS		P08919567531	8/31/2018	10/5/2018	550.00
ANDRE KEY	FF4E-COMM SVCS		P08919568129	8/31/2018	10/5/2018	550.00
ANDRE KEY	FF4E-COMM SVCS		P08919568630	8/31/2018	10/5/2018	550.00
BELIEVE IN ME YOUTH & FAMILY	COMM SVCS		P09000918170	9/30/2018	10/12/2018	900.00
BELIEVE IN ME YOUTH & FAMILY	COMM SVCS		P09919706571	9/30/2018	10/12/2018	1,125.00
BELIEVE IN ME YOUTH & FAMILY	FF4E-COMM SVCS		P09919722181	9/30/2018	10/12/2018	900.00
BELIEVE IN ME YOUTH & FAMILY	FF4E-COMM SVCS		P09919722380	9/30/2018	10/12/2018	900.00
C.M. MENTORING SERVICES LLC	COMM SVCS		P09000920020	9/30/2018	10/5/2018	1,125.00
	POS MANDATED FFOP		P09919714884	9/30/2018	10/12/2018	1,143.00
	POS MANDATED FFOP		P09919705785	9/30/2018	10/12/2018	1,591.00
	POS MANDATED FFOP		P09919714786	9/30/2018	10/12/2018	2,487.00
CHRISTINE BOWERS LMFT, LLC	COMM SVCS		P09919729772	9/30/2018	10/12/2018	250.00
COMMONWEALTH CATHOLIC	FF4E-COMM SVCS		P09919722510	9/30/2018	10/19/2018	60.00
DETOUR MENTORING	COMM SVCS		P09919728173	9/30/2018	10/12/2018	1,100.00
DETOUR MENTORING	COMM SVCS		P10919719515	10/31/2018	10/26/2018	660.00
DETOUR MENTORING	COMM SVCS		P10919728116	10/31/2018	10/26/2018	1,100.00

**County of Fluvanna
Accounts Payable List**

**From Date: 10/1/2018
To Date: 10/31/2018**



DETOUR MENTORING	COMM SVCS	P10919723417	10/31/2018	10/26/2018	1,375.00
DETOUR MENTORING	COMM SVCS	P10919721518	10/31/2018	10/26/2018	1,650.00
DETOUR MENTORING	POS MANDATED WSS	P10000920521	10/31/2018	10/26/2018	1,045.00
DETOUR MENTORING	POS MANDATED WSS	P10000920122	10/31/2018	10/26/2018	1,705.00
	POS MANDATED FFOP	P09919719739	9/30/2018	10/5/2018	1,820.00
	POS MANDATED FFOP	P09919704640	9/30/2018	10/5/2018	2,044.00
DISCOVERY SCHOOL OF VA, INC	EDUC SVCS CONG CARE	P07919701126	7/31/2018	10/5/2018	2,542.00
DISCOVERY SCHOOL OF VA, INC	EDUC SVCS CONG CARE	P09000923078	9/30/2018	10/12/2018	5,910.00
DISCOVERY SCHOOL OF VA, INC	EDUC SVCS CONG CARE	P07000915077	7/31/2018	10/12/2018	5,952.00
DISCOVERY SCHOOL OF VA, INC	EDUC SVCS CONG CARE	P08000915075	8/31/2018	10/12/2018	5,952.00
DISCOVERY SCHOOL OF VA, INC	POS MAND FC LIC RES CONG	P07919701028	7/31/2018	10/5/2018	3,410.00
DISCOVERY SCHOOL OF VA, INC	POS MANDATED WSS	P07000922249	7/31/2018	10/5/2018	150.00
DISCOVERY SCHOOL OF VA, INC	POS MANDATED WSS	P08000922248	8/31/2018	10/5/2018	200.00
DISCOVERY SCHOOL OF VA, INC	RES. CONG. CARE	P07000918942	7/31/2018	10/5/2018	3,159.00
DISCOVERY SCHOOL OF VA, INC	RES. CONG. CARE	P08000918941	8/31/2018	10/5/2018	3,627.00
ED MURPHY & ASSOCIATES	EDUC SVCS CONG CARE	P07000921027	7/31/2018	10/5/2018	3,740.00
ED MURPHY & ASSOCIATES	EDUC SVCS CONG CARE	P08000921124	8/31/2018	10/5/2018	3,910.00
ED MURPHY & ASSOCIATES	EDUC SVCS CONG CARE	P09000921209	9/30/2018	10/19/2018	3,400.00
EXTRA SPECIAL PARENTS, INC.	POS MANDATED WSS	P08000915487	8/31/2018	10/12/2018	300.00
FAMILY PRESERVATION SERV.	COMM SVCS	P08919723361	8/31/2018	10/12/2018	90.00
FAMILY PRESERVATION SERV.	COMM SVCS	P09919723304	9/30/2018	10/19/2018	1,275.00
FAMILY PRESERVATION SERV.	COMM SVCS	P07919703814	7/31/2018	10/26/2018	1,062.50
FAMILY PRESERVATION SERV.	FF4E-COMM SVCS	P09919707711	9/30/2018	10/19/2018	770.00
FAMILY PRESERVATION SERV.	POS MANDATED WSS	P09000918313	9/30/2018	10/19/2018	1,200.00
FLUVANNA DEPARTMENT OF SOCIAL	COMM SVCS	P07919724716	7/30/2018	10/5/2018	1,315.00
GPM INVESTMENTS LLC	COMM SVCS	P07919710317	7/31/2018	10/5/2018	140.00
GPM INVESTMENTS LLC	COMM SVCS	P08919710313	8/31/2018	10/5/2018	175.00
GRAFTON INTERGRATED HEALTH	EDUC SVCS CONG CARE	P07000917676	7/31/2018	10/12/2018	8,550.00
GRAFTON INTERGRATED HEALTH	EDUC SVCS CONG CARE	P08000917674	8/31/2018	10/12/2018	8,705.00
INTERCEPT YOUTH SERVICE	EDUC SVCS CONG CARE	P07000919108	7/31/2018	10/19/2018	3,762.38
INTERCEPT YOUTH SERVICE	RES. CONG. CARE	P07000919212	7/31/2018	10/19/2018	7,916.47
	POS MANDATED FFOP	P09919712537	9/30/2018	10/5/2018	1,820.00
LAFAYETTE SCHOOL, INC.	POS MANDATED SPED-PRIVATE	P08000921812	8/31/2018	10/5/2018	3,835.00
LAFAYETTE SCHOOL, INC.	POS MANDATED SPED-PRIVATE	P09000921655	9/30/2018	10/12/2018	2,850.00
LAFAYETTE SCHOOL, INC.	POS MANDATED SPED-PRIVATE	P09000916857	9/30/2018	10/12/2018	5,605.00
LAFAYETTE SCHOOL, INC.	POS MANDATED SPED-PRIVATE	P09000921956	9/30/2018	10/12/2018	5,605.00
	POS MANDATED FFOP	P09919705936	9/30/2018	10/5/2018	1,815.00
	POS MANDATED FFOP	P09919706235	9/30/2018	10/5/2018	1,815.00
NATIONAL COUNSELING GROUP	COMM SVCS	P07000919566	7/31/2018	10/12/2018	948.75

**County of Fluvanna
Accounts Payable List**

**From Date: 10/1/2018
To Date: 10/31/2018**



NATIONAL COUNSELING GROUP	COMM SVCS	P08000919562	8/31/2018	10/12/2018	1,100.00
NATIONAL COUNSELING GROUP	COMM SVCS	P07000919367	7/31/2018	10/12/2018	1,752.03
NATIONAL COUNSELING GROUP	COMM SVCS	P08000919363	8/31/2018	10/12/2018	1,946.70
NORTHSTAR ACADEMY, INC.	POS MANDATED SPED-PRIVATE	P09000921594	9/30/2018	10/19/2018	1,672.00
PEOPLE PLACES, INC.	FF4E-COMM SVCS	P08919707619	8/31/2018	10/26/2018	637.50
PEOPLE PLACES, INC.	POS MAND THER FC 4E	P07919567745	7/31/2018	10/5/2018	2,760.00
PEOPLE PLACES, INC.	POS MAND THER FC 4E	P07919568346	7/31/2018	10/5/2018	3,720.00
PEOPLE PLACES, INC.	POS MAND THER FC 4E	P07919568847	7/31/2018	10/5/2018	3,720.00
PEOPLE PLACES, INC.	POS MAND THER FC 4E	P08919568343	8/31/2018	10/5/2018	3,720.00
PEOPLE PLACES, INC.	POS MAND THER FC 4E	P08919568844	8/31/2018	10/5/2018	3,720.00
PEOPLE PLACES, INC.	POS MAND THER FC 4E	P08919707520	8/31/2018	10/26/2018	3,720.00
REBECCA MAYO PITTS	COMM SVCS	P07919720718	7/31/2018	10/5/2018	440.00
REBECCA MAYO PITTS	COMM SVCS	P08919720714	8/31/2018	10/5/2018	440.00
SECURE CHILD IN- HOME PROGRAM	COMM SVCS	P07919569719	7/31/2018	10/5/2018	1,680.00
SECURE CHILD IN- HOME PROGRAM	COMM SVCS	P08919569715	8/31/2018	10/5/2018	1,680.00
SECURE CHILD IN- HOME PROGRAM	COMM SVCS	P07919569868	7/31/2018	10/12/2018	400.00
SECURE CHILD IN- HOME PROGRAM	COMM SVCS	P07919701469	7/31/2018	10/12/2018	400.00
SECURE CHILD IN- HOME PROGRAM	COMM SVCS	P08919569864	8/31/2018	10/12/2018	400.00
SECURE CHILD IN- HOME PROGRAM	COMM SVCS	P08919701465	8/31/2018	10/12/2018	400.00
SECURE CHILD IN- HOME PROGRAM	COMM SVCS	P09919721305	9/30/2018	10/19/2018	1,800.00
SECURE CHILD IN- HOME PROGRAM	COMM SVCS. TRANSITION	P07919701322	7/31/2018	10/5/2018	2,065.00
SECURE CHILD IN- HOME PROGRAM	COMM SVCS. TRANSITION	P08919701321	8/31/2018	10/5/2018	2,205.00
	COMM SVCS	P09919721206	9/30/2018	10/19/2018	1,460.00
SUSAN DALY	POS MANDATED FFOP	P09919702682	9/30/2018	10/12/2018	448.00
SUSAN DALY	POS MANDATED FFOP	P09919702583	9/30/2018	10/12/2018	700.00
THE DISCOVERY SCHOOL OF VA FOR	EDUC SVCS CONG CARE	P07000918825	7/31/2018	10/5/2018	2,295.00
THE DISCOVERY SCHOOL OF VA FOR	EDUC SVCS CONG CARE	P08000918823	8/31/2018	10/5/2018	2,635.00
THE FAISON CENTER	POS MANDATED SPED-PRIVATE	P08000917488	8/31/2018	10/19/2018	4,650.00
THE FAISON CENTER	POS MANDATED SPED-PRIVATE	P09000917495	9/30/2018	10/19/2018	5,890.00
THE FAISON CENTER	POS MANDATED SPED-PRIVATE	P07000917492	7/31/2018	10/19/2018	6,200.00
THE FAISON CENTER	POS MANDATED SPED-PRIVATE	P09000917396	9/30/2018	10/19/2018	6,205.00
THE FAISON CENTER	POS MANDATED SPED-PRIVATE	P07000917293	7/31/2018	10/19/2018	6,515.00
THE FAISON CENTER	POS MANDATED SPED-PRIVATE	P09000922497	9/30/2018	10/19/2018	9,340.00
UNITED METHODIST FAMILY	EDUC SVCS CONG CARE	P08000919807	8/31/2018	10/19/2018	4,080.00
	POS MANDATED FFOP	P09919706338	9/30/2018	10/5/2018	2,716.00
VIRGINIA CHILD & FAMILY	FF4E-COMM SVCS	P08919713479	8/31/2018	10/12/2018	4,995.00
VIRGINIA INSTITUTE OF AUTISM	POS MANDATED SPED-PRIVATE	P09000922659	9/30/2018	10/12/2018	8,723.00
VIRGINIA INSTITUTE OF AUTISM	POS MANDATED SPED-PRIVATE	P09000922858	9/30/2018	10/12/2018	8,723.00
VIRGINIA INSTITUTE OF AUTISM	POS MANDATED SPED-PRIVATE	P09000922760	9/30/2018	10/12/2018	8,879.00

**County of Fluvanna
Accounts Payable List**

**From Date: 10/1/2018
To Date: 10/31/2018**



VIRGINIA INSTITUTE OF AUTISM	POS MANDATED SPED-PRIVATE	P07000922651	7/31/2018	10/12/2018	9,321.00
VIRGINIA INSTITUTE OF AUTISM	POS MANDATED SPED-PRIVATE	P07000922852	7/31/2018	10/12/2018	9,516.00
VIRGINIA INSTITUTE OF AUTISM	POS MANDATED SPED-PRIVATE	P07000922753	7/31/2018	10/12/2018	9,672.00
VIRGINIA INSTITUTE OF AUTISM	POS MANDATED SPED-PRIVATE	P08000922950	8/31/2018	10/12/2018	10,929.00
VIRGINIA INSTITUTE OF AUTISM	POS MANDATED SPED-PRIVATE	P07000922954	7/31/2018	10/12/2018	14,337.00
VIRGINIA INSTITUTE OF AUTISM	POS MANDATED SPED-PRIVATE	P08000922689	8/31/2018	10/19/2018	7,280.00
VIRGINIA INSTITUTE OF AUTISM	POS MANDATED SPED-PRIVATE	P08000922890	8/31/2018	10/19/2018	7,319.00
VIRGINIA INSTITUTE OF AUTISM	POS MANDATED SPED-PRIVATE	P08000922791	8/31/2018	10/19/2018	7,514.00
Total:					\$331,202.33

PARKS & RECREATION

AUTOMATED OFFICE SYSTEMS	LEASE/RENT	COPIER MONTHLY CHARGES	083236	10/2/2018	10/12/2018	29.69
AUTOMATED OFFICE SYSTEMS	LEASE/RENT	COPIER MONTHLY CHARGES	083237	10/2/2018	10/12/2018	129.00
BANK OF AMERICA	RECREATIONAL SUPPLIES	P-CARD	093018	9/30/2018	10/16/2018	45.99
BONNIE SNODDY	PROFESSIONAL SERVICES	KARATE	9	10/1/2018	10/5/2018	616.00
BRIAN BENCE	RECREATIONAL SUPPLIES	MAGIC SHOW AT LIBRARY FOR	100118	10/1/2018	10/26/2018	225.00
CENTURYLINK	TELECOMMUNICATIONS	PARKS & RECREATION	309373828 0911618	9/16/2018	10/5/2018	288.52
CINTAS	CONTRACT SERVICES	FIRST AID SUPPLIES	5011984247	10/15/2018	10/19/2018	66.96
CINTAS	CONTRACT SERVICES	FIRST AID SUPPLIES	5011984248	10/15/2018	10/19/2018	177.59
DEVI PETERSON	PROFESSIONAL SERVICES	YOGA	10 101118	10/9/2018	10/12/2018	114.80
DJ RICK HAGGARD ENTERTAINMENT	PROFESSIONAL SERVICES	MUSIC FOR TEEN DANCE	88201832116102018B	10/23/2018	10/26/2018	300.00
FUN EXPRESS LLC	RECREATIONAL SUPPLIES	HALLOWEEN PARTY SUPPLIES	692191428-01	9/28/2018	10/12/2018	363.88
JAMES RIVER SOLUTIONS	VEHICLE FUEL	FUEL	100218	10/2/2018	10/12/2018	98.70
MO-JOHNS, INC.	CONTRACT SERVICES	EQUESTRIAN FIELD	113042	10/1/2018	10/5/2018	60.00
MO-JOHNS, INC.	CONTRACT SERVICES	PLEASANT GROVE BALL FIELDS	113043	10/1/2018	10/5/2018	60.00
MO-JOHNS, INC.	CONTRACT SERVICES	POLE BARN PLEASANT GROVE	113046	10/1/2018	10/5/2018	60.00
MO-JOHNS, INC.	CONTRACT SERVICES	CARYSBROOK	113045	10/1/2018	10/5/2018	100.00
MO-JOHNS, INC.	CONTRACT SERVICES	SOCCER FIELD AT PLEASANT GROVE	113044	10/1/2018	10/5/2018	120.00
POSTMASTER	POSTAL SERVICES	P.O. BOX PAYMENT	101718	10/17/2018	10/19/2018	116.00
RAFALY ELECTRICAL CONTRACTORS,	SITE IMPROVEMENTS	PLEASANT GROVE - POWER FOR RV AND	8022	9/26/2018	10/5/2018	6,067.00
SAM'S CLUB	RECREATIONAL SUPPLIES	ACCT # 9179	101218	10/12/2018	10/19/2018	193.42
THE SUPPLY ROOM	OFFICE SUPPLIES	OFFICE SUPPLIES	3455225-0	10/2/2018	10/12/2018	53.64
THE SUPPLY ROOM	UNIFORM/WEARING APPAREL	WATERPROOF JACKETS	3436795-0	9/27/2018	10/5/2018	292.27
VERIZON BUSINESS/MCI COMM	TELECOMMUNICATIONS	MONTHLY CHARGES	05619915	9/25/2018	10/5/2018	19.06
VERIZON	TELECOMMUNICATIONS	MONTHLY CHARGES	721970783-00001 1019	10/19/2018	10/26/2018	200.72
VIRGINIA BUSINESS SYSTEMS	LEASE/RENT	COPIER	23411163	9/24/2018	10/5/2018	46.45
VIRGINIA BUSINESS SYSTEMS	LEASE/RENT	COPIER	23411161	9/24/2018	10/5/2018	115.56
VIRGINIA RECREATION & PARK	RECREATIONAL SUPPLIES	KINGS DOMINION TICKETS SOLD	31639	9/26/2018	10/5/2018	240.00
Total:					\$10,200.25	

**County of Fluvanna
Accounts Payable List**

**From Date: 10/1/2018
To Date: 10/31/2018**



LIBRARY							
ADVANTAGE OFFICE SYSTEMS	OFFICE SUPPLIES	PRINTER TONER	7137	10/11/2018	10/19/2018		119.00
AMAZON.COM	BOOKS/PUBLICATIONS	BOOKS & DVDS	10/10/18	10/10/2018	10/26/2018		8,074.10
BANK OF AMERICA	BOOKS/PUBLICATIONS	P-CARD	093018	9/30/2018	10/16/2018		12.00
BANK OF AMERICA	BOOKS/PUBLICATIONS	P-CARD	093018	9/30/2018	10/16/2018		52.57
GALE	BOOKS/PUBLICATIONS	BOOKS	65187681	9/20/2018	10/5/2018		21.59
GALE	BOOKS/PUBLICATIONS	BOOKS	65234901	9/24/2018	10/5/2018		24.00
GALE	BOOKS/PUBLICATIONS	BOOKS	65288232	9/27/2018	10/12/2018		21.59
GALE	BOOKS/PUBLICATIONS	BOOKS	65343995	10/3/2018	10/12/2018		61.58
GALE	BOOKS/PUBLICATIONS	BOOKS	65390017	10/9/2018	10/19/2018		55.98
GALE	BOOKS/PUBLICATIONS	BOOKS	65399248	10/10/2018	10/19/2018		67.20
MICROMARKETING LLC	BOOKS/PUBLICATIONS	DVDS	738782	9/24/2018	10/5/2018		38.97
MICROMARKETING LLC	BOOKS/PUBLICATIONS	DVD	739362	9/26/2018	10/12/2018		47.98
SHOWCASES	OFFICE SUPPLIES	CD PAGES	308547	10/5/2018	10/26/2018		113.40
SHOWCASES	OFFICE SUPPLIES	CD CASES	308546	10/5/2018	10/26/2018		752.76
STAPLES CONTRACT & COMMERCIAL, VA INFORMATION	OFFICE SUPPLIES	OFFICE SUPPLIES	2163535011	10/15/2018	10/26/2018		55.76
	TELECOMMUNICATIONS	LONG DISTANCE	T418458	9/27/2018	10/5/2018		3.86
Total:							\$9,522.34
COUNTY PLANNER							
BANK OF AMERICA	CONVENTION AND EDUCATION	P-CARD	093018	9/30/2018	10/16/2018		(\$200.00)
CANON FINANCIAL SERVICES, INC.	LEASE/RENT	COPIER MONTHLY CHARGES	19235147	9/21/2018	10/5/2018		320.00
CANON FINANCIAL SERVICES, INC.	LEASE/RENT	COPIER MONTHLY CHARGES	19279789	10/13/2018	10/26/2018		320.00
HOLLY STEELE	MILEAGE ALLOWANCES	MILEAGE REIMBURSEMENT - SMART	102518	10/23/2018	10/26/2018		55.59
JAMES RIVER SOLUTIONS	VEHICLE FUEL	FUEL	100218	10/2/2018	10/12/2018		109.33
MANSFIELD OIL COMPANY OF	VEHICLE FUEL	FUEL 9/16/18- 9/30/18	SQLCD-449684	10/2/2018	10/5/2018		54.50
MANSFIELD OIL COMPANY OF	VEHICLE FUEL	FUELS INVOICE 10/01/18 - 10/15/18	SQLCD-452785	10/16/2018	10/19/2018		26.04
PITNEY BOWES PURCHASE PWR	POSTAL SERVICES	POSTAGE	01515654 101818	10/16/2018	10/26/2018		0.47
STAPLES CONTRACT & COMMERCIAL, VERIZON	OFFICE SUPPLIES	OFFICE SUPPLIES	8051666987	10/6/2018	10/19/2018		51.12
VERIZON	TELECOMMUNICATIONS	MONTHLY CHARGES	721970783-00001 1019	10/19/2018	10/26/2018		150.54
VIRGINIA BUSINESS SYSTEMS	LEASE/RENT	COPIER	23411162	9/24/2018	10/5/2018		283.26
VIRGINIA BUSINESS SYSTEMS	LEASE/RENT	20160029-00 HP DESIGNJET T370	23439920	9/27/2018	10/12/2018		93.04
Total:							\$1,263.89
PLANNING COMMISSION							
ATLANTIC TECHNOLOGY	PROFESSIONAL SERVICES	APPLICATION REVIEW	1542	10/10/2018	10/12/2018		900.00
ATLANTIC TECHNOLOGY	PROFESSIONAL SERVICES	REVIEW	1545	10/18/2018	10/26/2018		900.00
Total:							\$1,800.00

**County of Fluvanna
Accounts Payable List**

**From Date: 10/1/2018
To Date: 10/31/2018**



ECONOMIC DEVELOPMENT

BANK OF AMERICA	CONVENTION AND EDUCATION	P-CARD	093018	9/30/2018	10/16/2018	17.95
BANK OF AMERICA	CONVENTION AND EDUCATION	P-CARD	093018	9/30/2018	10/16/2018	425.00
BANK OF AMERICA	MARKETING	P-CARD	093018	9/30/2018	10/16/2018	5.88
BANK OF AMERICA	MARKETING	P-CARD	093018	9/30/2018	10/16/2018	20.38
ECONOMIC DEVELOPMENT OF	FLU ECO DEV AUTHORITY	ANNUAL ALLOCATION	101118	10/3/2018	10/12/2018	1,000.00
STAPLES CONTRACT & COMMERCIAL,	OFFICE SUPPLIES	OFFICE SUPPLIES	8051666987	10/6/2018	10/19/2018	147.04
STAPLES CONTRACT & COMMERCIAL,	OTHER OPERATING SUPPLIES	OFFICE SUPPLIES	8051666987	10/6/2018	10/19/2018	52.95
VERIZON	TELECOMMUNICATIONS	MONTHLY CHARGES	721970783-00001 1019	10/19/2018	10/26/2018	50.18
Total:						\$1,719.38

VA COOPERATIVE EXTENSION

BANK OF AMERICA	CONTRACT SERVICES	P-CARD	093018	9/30/2018	10/16/2018	40.80
FAYE ANDERSON	AGRICULTURAL SUPPLIES	CATTLEMANS PROGRAM SUPPLIES	100918	10/9/2018	10/12/2018	9.31
FAYE ANDERSON	AGRICULTURAL SUPPLIES	SENIOR GARDEN SEVIN	100918B	10/9/2018	10/12/2018	15.21
THE SUPPLY ROOM	AGRICULTURAL SUPPLIES	PAPER PRODUCTS	3448263-0	9/27/2018	10/5/2018	146.25
TREASURER OF VA TECH	CONVENTION AND EDUCATION	KIMBERLY BUONOMO 4-H INSTRUCTOR	101618	10/16/2018	10/16/2018	130.00
VESA	DUES OR ASSOCIATION	VESA DUES	101718	10/17/2018	10/19/2018	210.00
VIRGINIA COOPERATIVE EXTENSION	CONTRACT SERVICES	BILLING SALARY FY2019 1ST QUARTER	EXT062000 100318	10/3/2018	10/12/2018	12,143.73
Total:						\$12,695.30

NON PROFITS

BANK OF AMERICA	YOUTH ADVISORY COUNCIL	P-CARD	093018	9/30/2018	10/16/2018	30.33
FLUVANNA/LOUISA HOUSING	INTERAGENCY COUNCIL	FY19 CONTRIBUTION	092818	9/28/2018	10/5/2018	750.00
JAUNT, INC.	JAUNT	FY19 2ND QTR ALLOCATION	100118	10/1/2018	10/5/2018	21,250.00
JEFFERSON AREA BOARD FOR AGING	JEFFERSON AREA	FY19 2ND QTR ALLOCATION	100118	10/1/2018	10/5/2018	21,250.00
JEFFERSON AREA CHIP	JEFFERSON AREA CHIP	FY19 2ND QTR ALLOCATION	100118	10/1/2018	10/5/2018	13,005.00
MONTICELLO AREA COMMUNITY	MACAA	FY19 2ND QTR ALLOCATION	100118	10/1/2018	10/5/2018	12,500.00
PIEDMONT VIRGINIA COMMUNITY	PIEDMONT VA. COMM. COLLEGE	FY19 2ND QTR ALLOCATION	100118	10/1/2018	10/5/2018	12,606.50
REGION TEN	REGION TEN COMMUNITY	FY19 2ND QTR ALLOCATION	100118	10/1/2018	10/5/2018	31,562.50
THOMAS JEFFERSON PLANNING	T J PLANNING DIST. COMM.	FY19 2ND QTR ALLOCATION	100118	10/1/2018	10/5/2018	8,475.00
Total:						\$121,429.33

100 GENERAL FUND Fund Total: \$1,105,684.52

Fund # - 302 CAPITAL IMPROVEMENT

IT CAPITAL PROJECT

COMPUTER CABLING & TECHNOLOGY	CONTRACT SERVICES	FIBER OPTIC SUPPLIES	110729A	7/13/2018	10/19/2018	8,455.80
Total:						\$8,455.80

**County of Fluvanna
Accounts Payable List**

**From Date: 10/1/2018
To Date: 10/31/2018**



PUBLIC SAFETY CAPITAL PROJ

BANK OF AMERICA	VEHICLE	P-CARD	093018	9/30/2018	10/16/2018	114.95
BANK OF AMERICA	VEHICLE	P-CARD	093018	9/30/2018	10/16/2018	530.13
CLEAR COMMUNICATIONS AND PERFORMANCE SIGNS	VEHICLE	CAR MAINTENANCE	117189	9/18/2018	10/5/2018	2,868.19
	VEHICLE	CHARGER STRIPING PACKAGE	17725	9/24/2018	10/5/2018	830.00
Total:						\$4,343.27

FIRE & RESCUE CAP PROJ

UNDERHILL ENGINEERING, LLC	PROFESSIONAL SERVICES	SOIL TESTING	2018-1096	10/5/2018	10/12/2018	1,400.00
Total:						\$1,400.00

FACILITIES CAP PROJ

CII SERVICE	CONTRACT SERVICES	PALMYRA RESCUE SQUAD DUCT	43962	9/30/2018	10/26/2018	1,156.87
RAFALY ELECTRICAL CONTRACTORS,	CONTRACT SERVICES	SHERIFF OFFICE - ELECTRICAL FOR	8048	9/28/2018	10/19/2018	2,991.00
RAFALY ELECTRICAL CONTRACTORS,	CONTRACT SERVICES	RESCUE SQUAD BLDG REPLACE OUTLET	8091	10/18/2018	10/26/2018	1,501.00
W.W. GRAINGER INC	CONTRACT SERVICES	SHELVING	9933349863	10/12/2018	10/19/2018	665.00
Total:						\$6,313.87

SCHOOL OPS & MAINT CAP PROJ

BARRANGER & COMPANY, INC.	CONTRACT SERVICES	ACCORDION DOOR INSTALLATION	18-544A	10/3/2018	10/12/2018	11,864.00
MIKE'S STAIN & PAINT INC	CONTRACT SERVICES	PAINTING 6 DOORS AT FCMS	1722	9/26/2018	10/5/2018	650.00
MITCHELL ROOFING, INC.	CONTRACT SERVICES	CARYSBROOK ROOF	0576	9/21/2018	10/5/2018	1,654.00
MITCHELL ROOFING, INC.	CONTRACT SERVICES	CARYSBROOK ROOF	0603	9/28/2018	10/5/2018	112,500.00
PARAGON SOLUTIONS INC	CONTRACT SERVICES	ABRAMS ABATEMENT	18-3-108c	9/17/2018	10/5/2018	14,310.00
Total:						\$140,978.00

302 CAPITAL IMPROVEMENT Fund Total: \$161,490.94

Fund # - 502 SEWER

PALMYRA SEWER OPER EXPENSES

DOMINION VIRGINIA POWER	ELECTRICAL SERVICES	JAMES MADISON HWY # PUMP	7712348080 092618	9/26/2018	10/12/2018	39.21
DOMINION VIRGINIA POWER	ELECTRICAL SERVICES	SEWER PLANT	7129524547 092418	9/24/2018	10/12/2018	607.60
Total:						\$646.81

502 SEWER Fund Total: \$646.81

Fund # - 505 FORK UNION SANITARY DISTRICT

FORK UNION SANITARY DISTRICT

BHF REAL ESTATE III -HOUSE	WATER RECEIVABLES	UB 10035 423 BREMO BLUFF	64190	9/7/2018	10/5/2018	42.00
USDA RURAL DEVELOPMENT	RDA BOND PAYABLE	FUSD DEBT SERVICE	102518	10/25/2018	10/25/2018	1,520.31

**County of Fluvanna
Accounts Payable List**

**From Date: 10/1/2018
To Date: 10/31/2018**



						Total:	\$1,562.31
FUSD OPERATIONAL EXPENSES							
BFI - FLUVANNA TRANSFER STATION	PROFESSIONAL SERVICES	TRASH	4347-000006192	9/30/2018	10/19/2018	4,072.11	
DOMINION VIRGINIA POWER	ELECTRICAL SERVICES	2622 BREMO RD WEST BOTTOM WELL	7224360003 092518	9/25/2018	10/12/2018	6.59	
DOMINION VIRGINIA POWER	ELECTRICAL SERVICES	RT 15 MELTON WELL	9594215007 092518	9/25/2018	10/12/2018	36.49	
DOMINION VIRGINIA POWER	ELECTRICAL SERVICES	RT 666 BREMO WELL	8434345008 092518	9/25/2018	10/12/2018	49.55	
DOMINION VIRGINIA POWER	ELECTRICAL SERVICES	4308 JAMES MADISON HWY	9004200003 092518	9/25/2018	10/12/2018	212.27	
DOMINION VIRGINIA POWER	ELECTRICAL SERVICES	14349 W RIVER RD OMOHUNDRO WELL	9346182505 092518	9/25/2018	10/12/2018	745.30	
DOMINION VIRGINIA POWER	ELECTRICAL SERVICES	41 EMERALD RD MORRIS WELL	9501772108 092518	9/25/2018	10/12/2018	934.26	
E.W. OWEN	LEASE/RENT	WELL RENT	10012018	10/1/2018	10/5/2018	150.00	
SCHNEIDER LABRATORIES INC	PURCHASE OF SERVICES	WATER TESTING	280866	9/25/2018	10/19/2018	30.00	
SYDNOR HYDRO, INC.	BLDGS EQUIP REP & MAINT	FLOW CONTROL VALVE	78345	9/25/2018	10/12/2018	1,077.35	
USABLUEBOOK	BLDGS EQUIP REP & MAINT	PUMP	690104	9/21/2018	10/12/2018	710.01	
USDA RURAL DEVELOPMENT	REDEMPTION OF INTEREST	FUSD DEBT SERVICE	102518	10/25/2018	10/25/2018	3,439.69	
						Total:	\$11,463.62
505 FORK UNION SANITARY DISTRICT						Fund Total:	\$13,025.93
Fund # - 510 ZION XR WATER & SEWER							
ZION XR W&S EXPENSES							
BOWMAN CONSULTING	PROFESSIONAL SERVICES	PROJECT MANAGEMENT - AGREEMENT	260647	9/30/2018	10/12/2018	8,370.00	
PAYNE & HODOUS, LLP.	COUNTY ATTY LEGAL- REAL	LEGAL FEES	132632	10/3/2018	10/19/2018	4,412.50	
						Total:	\$12,782.50
510 ZION XR WATER & SEWER						Fund Total:	\$12,782.50
						Total Expenditures by Fund:	\$1,293,630.70

**FLUVANNA COUNTY BOARD OF SUPERVISORS
AGENDA ITEM STAFF REPORT**

TAB D

MEETING DATE:	November 20, 2018				
AGENDA TITLE:	FY19 Library State Aid Supplemental Appropriation				
MOTION(s):	I move the Board of Supervisors approve a supplemental appropriation of \$629 to the FY19 Library State Aid budget for funds received from the Commonwealth of Virginia.				
STRATEGIC INITIATIVE?	Yes	No	If yes, list initiative(s):		
		X			
AGENDA CATEGORY:	Public Hearing	Action Matter	Presentation	Consent Agenda	Other
				X	
STAFF CONTACT(S):	Cyndi Hoffman, Library Director Eric Pollitt, Management Analyst				
PRESENTER(S):	Eric Pollitt, Management Analyst				
RECOMMENDATION:	I recommend approval of the motion as stated above.				
TIMING:	Routine				
DISCUSSION:	The County received notification of the funding appropriation from the Library of Virginia after the FY19 budget had been adopted.				
	The BOS adopted amount for FY19 totaled \$81,211, which is \$629 less than the Library of Virginia approved amount of \$81,840.				
FISCAL IMPACT:	Approval will allow finance to increase FY19 revenues and expenditures by \$629.				
	FY19 Library State Aid will be increased from \$81,211 to \$81,840.				
POLICY IMPACT:	N/A				
LEGISLATIVE HISTORY:	N/A				
ENCLOSURES:	None				
REVIEWS COMPLETED:	Legal	Finance	Purchasing	HR	Other
		X			

**FLUVANNA COUNTY BOARD OF SUPERVISORS
AGENDA ITEM STAFF REPORT**

TAB E

MEETING DATE:	November 20, 2018				
AGENDA TITLE:	Approval of Open Space Contract for William F. & Susan Hughes				
MOTION(s):	I move to approve the open space contract for William F. & Susan Hughes for tax map parcel 31-A-33; agreement shall remain in effect for a term of fifteen (15) consecutive years.				
STRATEGIC INITIATIVE?	Yes	No	If yes, list initiative(s):		
		X			
AGENDA CATEGORY:	Public Hearing	Action Matter	Presentation	Consent Agenda	Other
				X	
STAFF CONTACT(S):	Andrew M. Sheridan, Jr., Commissioner of the Revenue				
PRESENTER(S):	Andrew M. Sheridan, Jr., Commissioner of the Revenue				
RECOMMENDATION:	Approval				
TIMING:	Immediate				
DISCUSSION:	This property qualifies for an open space contract with Fluvanna County in accordance with Code Section 58.1-3229 et. seq. of the Virginia State Code.				
FISCAL IMPACT:	None				
POLICY IMPACT:	In accordance with Section 58.1-3229 et. seq. of Virginia State Code.				
LEGISLATIVE HISTORY:	N/A				
ENCLOSURES:	-William F. & Susan Hughes' executed open space contract -Map of tax map parcel 31-A-33				
REVIEWS COMPLETED:	Legal	Finance	Purchasing	HR	Other



CONTRACT FOR OPEN SPACE LAND USE ASSESSMENT

THIS AGREEMENT, made this 20th day of JULY, 2018, by and between William F. & Susan Hughes, party(ies) of the first part, hereinafter called the Grantor, and the COUNTY OF FLUVANNA, a political subdivision of the Commonwealth of Virginia, party of the second part, hereinafter called the County:

WITNESSETH

WHEREAS, the Grantor owns certain real estate, described below, hereinafter called the Property; and

WHEREAS, the County is the local governing body having real estate tax jurisdiction over the Property; and

WHEREAS, the County has determined:

- A. That it is in the public interest that the Property should be provided or preserved for conservation of agricultural and forestal land and of wildlife and
- B. That the property meets the applicable criteria for real estate devoted to open-space use as prescribed in Article 4 (Section 58.1-3229 et. seq.) of Chapter 32 of Title 58.1 of the Code of Virginia, and the standards for classifying such real estate prescribed by the Director of the Virginia Department of Conservation and Recreation; and
- C. That the provisions of this agreement meet the requirements and standards prescribed under section 58.1-3233 of the Code of Virginia for recorded commitments by landowners not to change an open-space use to a non-qualifying use; and

WHEREAS, the Grantor is willing to make a written recorded commitment to preserve and protect the open-space uses of the Property during the term of this agreement in order for the Property to be taxed on the basis of a use assessment, and the Grantor has submitted an application for such taxation to the Commissioner of the Revenue of the County pursuant to Section 58.1-3234 of the Code of Virginia and Section 20-4-2(d) of the Fluvanna County Code; and

WHEREAS, the County is willing to extend the tax for the Property on the basis of a use assessment commencing with the next succeeding tax year and continuing for the term of this agreement, in consideration of the Grantor's commitment to preserve and protect the open-space uses of the property, and on the condition that the Grantor's application is satisfactory and that all other requirements of Article 4, Chapter 32, Title 58.1 of the Code of Virginia and Section 20-4-2(d) of the Fluvanna County Code are complied with.

NOW, THEREFORE, in consideration of the recital and the mutual benefits, covenants and terms herein contained, the parties hereby **COVENANT** and **AGREE** as follows:

1. This agreement shall apply to all the following described real estate:

Tax Map Parcel: 31-A-33 (13.963 acres)

2. The Grantor agrees that during the term of this agreement:
 - A. There shall be no change in the use or uses of the Property that exist as of the date of this agreement to any use that would not qualify as open-space use. The qualifying use for the Property is conservation of agricultural and forestal land and of wildlife.
 - B. There shall be no display of billboards, signs or other advertisements on the property except to (i) state solely the name of the Grantor and the address of the Property, (ii) advertise the sale or lease of the Property, (iii) advertise the sale of goods or services produced pursuant to the permitted use of the Property, or (iv) provide warnings. No sign shall exceed four feet by four feet.
 - C. There shall be no construction, placement or maintenance of any structure on the Property unless such structure is either:
 - 1) on the Property as of the date of this agreement; or
 - 2) related to and compatible with the open-space uses of the Property which this agreement is intended to protect or provide for.
 - D. There shall be no dumping or storage of trash, garbage, ashes, waste, junk, abandoned property or other unsightly or offensive material on the Property.
 - E. There shall be no filling, excavating, mining, drilling, removal of topsoil, sand, gravel, rock, minerals, or other materials which alters the topography of the Property, except as required in the construction of permissible building structures and features under this agreement.

- F. There shall be no construction or placement of fences, screens, hedges, walls or other similar barriers which materially obstruct the public view of scenic areas of the Property.
 - G. The Grantor may engage in agricultural, horticultural or silvicultural activities and remove vegetation which constitutes a safety, a health or an ecological hazard, e.g., vegetation classified as noxious weed pursuant the Code of Virginia (1950), as amended.
 - H. There shall be no alteration or manipulation of natural water courses, shores, marshes, swamps, wetlands or other water bodies, nor any activities or uses which adversely affect water quality, level or flow.
 - I. On areas of the Property that are being provided or preserved for conservation of land, floodways or other natural resources, or that are to be left in a relatively natural or undeveloped state, there shall be no operation of dune buggies, all-terrain vehicles, motorcycles, motorbikes, snowmobiles or other motor vehicles, except to the extent necessary to inspect, protect or preserve the area.
 - J. There shall be no industrial or commercial activities, conducted on the property, except for the continuation of agricultural, horticultural or silvicultural activities; or activities that are conducted in a residence or an associated outbuilding such as garage, smokehouse, small shop or similar structure which is permitted on the property.
 - K. There shall be no separation or split-off of lots, pieces or parcels from the property. The Property may be sold or transferred during the term of this agreement only as the same entire parcel that is the subject to this agreement, provided, however, that the Grantor may grant to a public body or bodies open-space, conservation or historic preservation easements which apply to all or part of the Property.
3. This agreement shall be effective upon acceptance by the County, provided, however, that the real estate tax for the Property shall not be extended on the basis of its use value until the next succeeding tax year following timely application by the Grantor for the use assessment and taxation in accordance with Section 20-4-2(d) of the Fluvanna County Code. Thereafter, this agreement shall remain in effect for a terms of fifteen (15) consecutive years.

4. Nothing contained herein shall be construed as giving to the public a right to enter upon or to use the Property or any portion thereof, except as the Grantor may otherwise allow, consistent with the provisions of this agreement.
5. The County shall have the right at all reasonable times to enter the Property to determine whether the Grantor is complying with the provisions of this agreement.
6. Nothing in this agreement shall be construed to create in the public or member thereof a right to maintain a suit for any damages against the Grantor for any violation of this agreement.
7. Nothing in this agreement shall be construed to permit Grantor to conduct any activity or to build or maintain any improvement which is otherwise prohibited by law.
8. If any provision of this agreement is determined to be invalid by a court of competent jurisdiction, the remainder of the agreement shall not be affected thereby.
9. The provisions of this agreement shall run with the land and be binding upon the parties, their successors, assigns, personal representatives, and heirs.
10. Words of one gender used herein shall include the other gender, and words in the singular shall include words in the plural, whenever the sense requires.
11. This agreement may be terminated in the manner provided in Section 15.1-1513 of the Code of Virginia for withdrawal of land from an agricultural, forestal or an agricultural and forestal district.
12. Upon termination of this agreement, the Property shall thereafter be assessed and taxed at its fair market value, regardless of its actual use, unless the County determines otherwise in accordance with applicable law.
13. NOTICE: WHEN THE OPEN SPACE USE OR USES BY WHICH THE PROPERTY QUALIFIED FOR ASSESSMENT AND TAXATION ON THE BASIS OF USE CHANGES TO A NONQUALIFYING USE OR USES, OR WHEN THE ZONING FOR THE PROPERTY CHANGES TO A MORE INTENSIVE USE AT THE REQUEST OF THE GRANTOR, THE PROPERTY, OR SUCH PORTION OF THE PROPERTY WHICH NO LONGER QUALIFIES SHALL BE SUBJECT TO ROLLBACK TAXES IN ACCORDANCE WITH SECTION 58.1-3237 OF THE CODE OF VIRGINIA. THE GRANTOR SHALL BE SUBJECT TO ALL OF THE OBLIGATIONS AND LIABILITIES OF SAID CODES SECTION.

Wm J Hughes
Landowner (SEAL)

Susan A. Hughes
Co-owner (s) (SEAL)



**STATE OF VIRGINIA
COUNTY OF FLUVANNA, to-wit:**

The foregoing instrument was acknowledged before me by

William + Susan Hughes, Landowner (s)

on this 20th day of July, 2018.

My commission expires: 3/31/2022

Lauren R. Sheridan
Notary Public

COUNTY OF FLUVANNA, VIRGINIA

By: _____
County Administrator

**STATE OF VIRGINIA
COUNTY OF FLUVANNA, to-wit:**

The foregoing instrument was acknowledged before me by

_____, Fluvanna County Administrator

on this _____ day of _____, _____.

My commission expires: _____

Notary Public

Fluvanna County, VA WebGIS Parcels - PIN: 31A 33

Located off of Allen Lane in Palmyra, VA 22963

BOS 2018-11-20 p.348/421

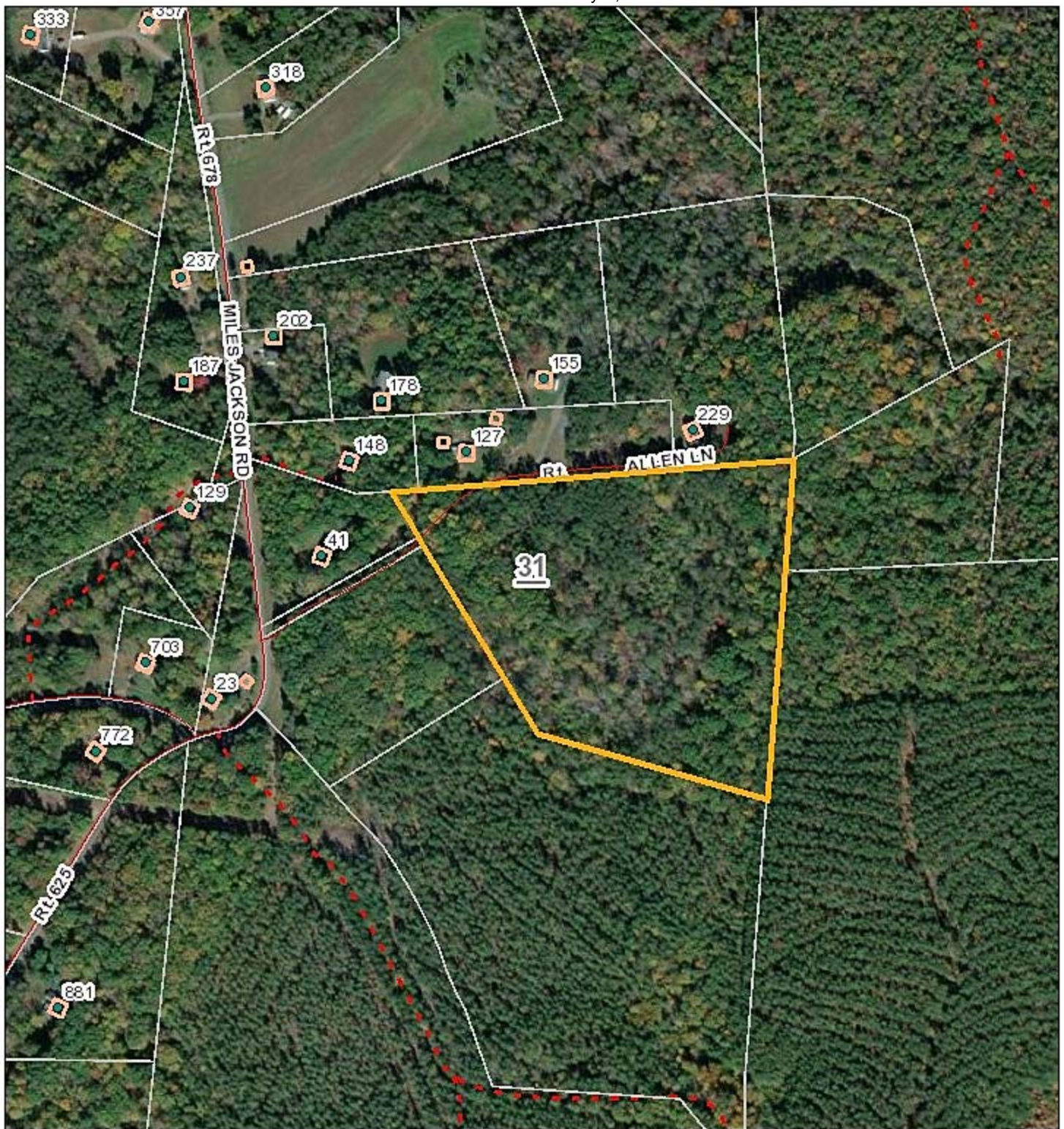

November 13, 2018

1:5,266

- | | | |
|------------------|-----------------------|------------------------|
| ● Address Points | ● Place Names | □ Surrounding Counties |
| Roads | — Town Boundary | □ Address Point Labels |
| — Interstate | + Railroads | Road Labels |
| — Primary | - - Driveways | — Interstate |
| — Secondary | □ Building Footprints | — Primary |
| — Other | □ Tax Map Grid | — Secondary |
| □ Parcels | □ County Boundary | — Other |

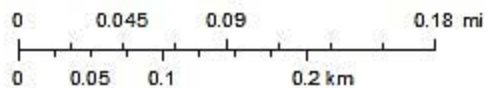

Source: Esri, DigitalGlobe, GeoEye, Earthstar Geographics, CNES/Airbus DS, USDA, USGS, AeroGRID, IGN, and the GIS User Community

**FLUVANNA COUNTY BOARD OF SUPERVISORS
AGENDA ITEM STAFF REPORT**

TAB F

MEETING DATE:	November 20, 2018				
AGENDA TITLE:	Approval of Open Space Contract for Otis H. & Helen H. McKee				
MOTION(s):	I move to approve the open space contract for Otis H. & Helen H. McKee for tax map parcel 25-1-9; agreement shall remain in effect for a term of ten (10) consecutive years.				
STRATEGIC INITIATIVE?	Yes	No	If yes, list initiative(s):		
		X			
AGENDA CATEGORY:	Public Hearing	Action Matter	Presentation	Consent Agenda	Other
				X	
STAFF CONTACT(S):	Andrew M. Sheridan, Jr., Commissioner of the Revenue				
PRESENTER(S):	Andrew M. Sheridan, Jr., Commissioner of the Revenue				
RECOMMENDATION:	Approval				
TIMING:	Immediate				
DISCUSSION:	This property qualifies for an open space contract with Fluvanna County in accordance with Code Section 58.1-3229 et. seq. of the Virginia State Code.				
FISCAL IMPACT:	None				
POLICY IMPACT:	In accordance with Section 58.1-3229 et. seq. of Virginia State Code.				
LEGISLATIVE HISTORY:	N/A				
ENCLOSURES:	-Otis H. & Helen H. McKee's executed open space contract -Map of tax map parcel 25-1-9				
REVIEWS COMPLETED:	Legal	Finance	Purchasing	HR	Other



CONTRACT FOR OPEN SPACE LAND USE ASSESSMENT

THIS AGREEMENT, made this 11th day of April, 2018 by and between Otis H. & Helen H. McKee, party(ies) of the first part, hereinafter called the Grantor, and the COUNTY OF FLUVANNA, a political subdivision of the Commonwealth of Virginia, party of the second part, hereinafter called the County:

WITNESSETH

WHEREAS, the Grantor owns certain real estate, described below, hereinafter called the Property; and

WHEREAS, the County is the local governing body having real estate tax jurisdiction over the Property; and

WHEREAS, the County has determined:

- A. That it is in the public interest that the Property should be provided or preserved for conservation of agricultural and forestal land and of wildlife and
- B. That the property meets the applicable criteria for real estate devoted to open-space use as prescribed in Article 4 (Section 58.1-3229 et. seq.) of Chapter 32 of Title 58.1 of the Code of Virginia, and the standards for classifying such real estate prescribed by the Director of the Virginia Department of Conservation and Recreation; and
- C. That the provisions of this agreement meet the requirements and standards prescribed under section 58.1-3233 of the Code of Virginia for recorded commitments by landowners not to change an open-space use to a non-qualifying use; and

WHEREAS, the Grantor is willing to make a written recorded commitment to preserve and protect the open-space uses of the Property during the term of this agreement in order for the Property to be taxed on the basis of a use assessment, and the Grantor has submitted an application for such taxation to the Commissioner of the Revenue of the County pursuant to Section 58.1-3234 of the Code of Virginia and Section 20-4-2(d) of the Fluvanna County Code; and

WHEREAS, the County is willing to extend the tax for the Property on the basis of a use assessment commencing with the next succeeding tax year and continuing for the term of this agreement, in consideration of the Grantor's commitment to preserve and protect the open-space uses of the property, and on the condition that the Grantor's application is satisfactory and that all other requirements of Article 4, Chapter 32, Title 58.1 of the Code of Virginia and Section 20-4-2(d) of the Fluvanna County Code are complied with.

NOW, THEREFORE, in consideration of the recital and the mutual benefits, covenants and terms herein contained, the parties hereby **COVENANT** and **AGREE** as follows:

1. This agreement shall apply to all the following described real estate:

Tax Map Parcel: 25-1-9 (15.88 acres of 17.88 total acres)

2. The Grantor agrees that during the term of this agreement:
 - A. There shall be no change in the use or uses of the Property that exist as of the date of this agreement to any use that would not qualify as open-space use. The qualifying use for the Property is conservation of agricultural and forestal land and of wildlife.
 - B. There shall be no display of billboards, signs or other advertisements on the property except to (i) state solely the name of the Grantor and the address of the Property, (ii) advertise the sale or lease of the Property, (iii) advertise the sale of goods or services produced pursuant to the permitted use of the Property, or (iv) provide warnings. No sign shall exceed four feet by four feet.
 - C. There shall be no construction, placement or maintenance of any structure on the Property unless such structure is either:
 - 1) on the Property as of the date of this agreement; or
 - 2) related to and compatible with the open-space uses of the Property which this agreement is intended to protect or provide for.
 - D. There shall be no dumping or storage of trash, garbage, ashes, waste, junk, abandoned property or other unsightly or offensive material on the Property.
 - E. There shall be no filling, excavating, mining, drilling, removal of topsoil, sand, gravel, rock, minerals, or other materials which alters the topography of the Property, except as required in the construction of permissible building structures and features under this agreement.

- F. There shall be no construction or placement of fences, screens, hedges, walls or other similar barriers which materially obstruct the public view of scenic areas of the Property.
 - G. The Grantor may engage in agricultural, horticultural or silvicultural activities and remove vegetation which constitutes a safety, a health or an ecological hazard, e.g., vegetation classified as noxious weed pursuant the Code of Virginia (1950), as amended.
 - H. There shall be no alteration or manipulation of natural water courses, shores, marshes, swamps, wetlands or other water bodies, nor any activities or uses which adversely affect water quality, level or flow.
 - I. On areas of the Property that are being provided or preserved for conservation of land, floodways or other natural resources, or that are to be left in a relatively natural or undeveloped state, there shall be no operation of dune buggies, all-terrain vehicles, motorcycles, motorbikes, snowmobiles or other motor vehicles, except to the extent necessary to inspect, protect or preserve the area.
 - J. There shall be no industrial or commercial activities, conducted on the property, except for the continuation of agricultural, horticultural or silvicultural activities; or activities that are conducted in a residence or an associated outbuilding such as garage, smokehouse, small shop or similar structure which is permitted on the property.
 - K. There shall be no separation or split-off of lots, pieces or parcels from the property. The Property may be sold or transferred during the term of this agreement only as the same entire parcel that is the subject to this agreement, provided, however, that the Grantor may grant to a public body or bodies open-space, conservation or historic preservation easements which apply to all or part of the Property.
3. This agreement shall be effective upon acceptance by the County, provided, however, that the real estate tax for the Property shall not be extended on the basis of its use value until the next succeeding tax year following timely application by the Grantor for the use assessment and taxation in accordance with Section 20-4-2(d) of the Fluvanna County Code. Thereafter, this agreement shall remain in effect for a terms of TEN (10) consecutive years.

4. Nothing contained herein shall be construed as giving to the public a right to enter upon or to use the Property or any portion thereof, except as the Grantor may otherwise allow, consistent with the provisions of this agreement.
5. The County shall have the right at all reasonable times to enter the Property to determine whether the Grantor is complying with the provisions of this agreement.
6. Nothing in this agreement shall be construed to create in the public or member thereof a right to maintain a suit for any damages against the Grantor for any violation of this agreement.
7. Nothing in this agreement shall be construed to permit Grantor to conduct any activity or to build or maintain any improvement which is otherwise prohibited by law.
8. If any provision of this agreement is determined to be invalid by a court of competent jurisdiction, the remainder of the agreement shall not be affected thereby.
9. The provisions of this agreement shall run with the land and be binding upon the parties, their successors, assigns, personal representatives, and heirs.
10. Words of one gender used herein shall include the other gender, and words in the singular shall include words in the plural, whenever the sense requires.
11. This agreement may be terminated in the manner provided in Section 15.1-1513 of the Code of Virginia for withdrawal of land from an agricultural, forestal or an agricultural and forestal district.
12. Upon termination of this agreement, the Property shall thereafter be assessed and taxed at its fair market value, regardless of its actual use, unless the County determines otherwise in accordance with applicable law.
13. NOTICE: WHEN THE OPEN SPACE USE OR USES BY WHICH THE PROPERTY QUALIFIED FOR ASSESSMENT AND TAXATION ON THE BASIS OF USE CHANGES TO A NONQUALIFYING USE OR USES, OR WHEN THE ZONING FOR THE PROPERTY CHANGES TO A MORE INTENSIVE USE AT THE REQUEST OF THE GRANTOR, THE PROPERTY, OR SUCH PORTION OF THE PROPERTY WHICH NO LONGER QUALIFIES SHALL BE SUBJECT TO ROLLBACK TAXES IN ACCORDANCE WITH SECTION 58.1-3237 OF THE CODE OF VIRGINIA. THE GRANTOR SHALL BE SUBJECT TO ALL OF THE OBLIGATIONS AND LIABILITIES OF SAID CODES SECTION.

[Signature] (SEAL)
Landowner

[Signature] (SEAL)
Co-owner (s)

**STATE OF VIRGINIA
COUNTY OF FLUVANNA, to-wit:**

The foregoing instrument was acknowledged before me by

OTIS H & HELEN H. MCKEE, Landowner (s)

on this *11th* day of *April*, *2018*.

My commission expires: *April 30, 2020*

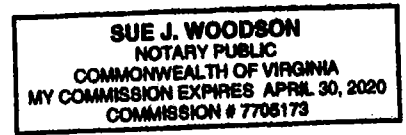

[Signature]
Notary Public

COUNTY OF FLUVANNA, VIRGINIA

By: _____
County Administrator

**STATE OF VIRGINIA
COUNTY OF FLUVANNA, to-wit:**

The foregoing instrument was acknowledged before me by

_____, Fluvanna County Administrator

on this _____ day of _____, _____.

My commission expires: _____

Notary Public

Fluvanna County, VA WebGIS Parcels - PIN: 25119

Located at 305 Ridge Spring Road, Scottsville, VA 24590

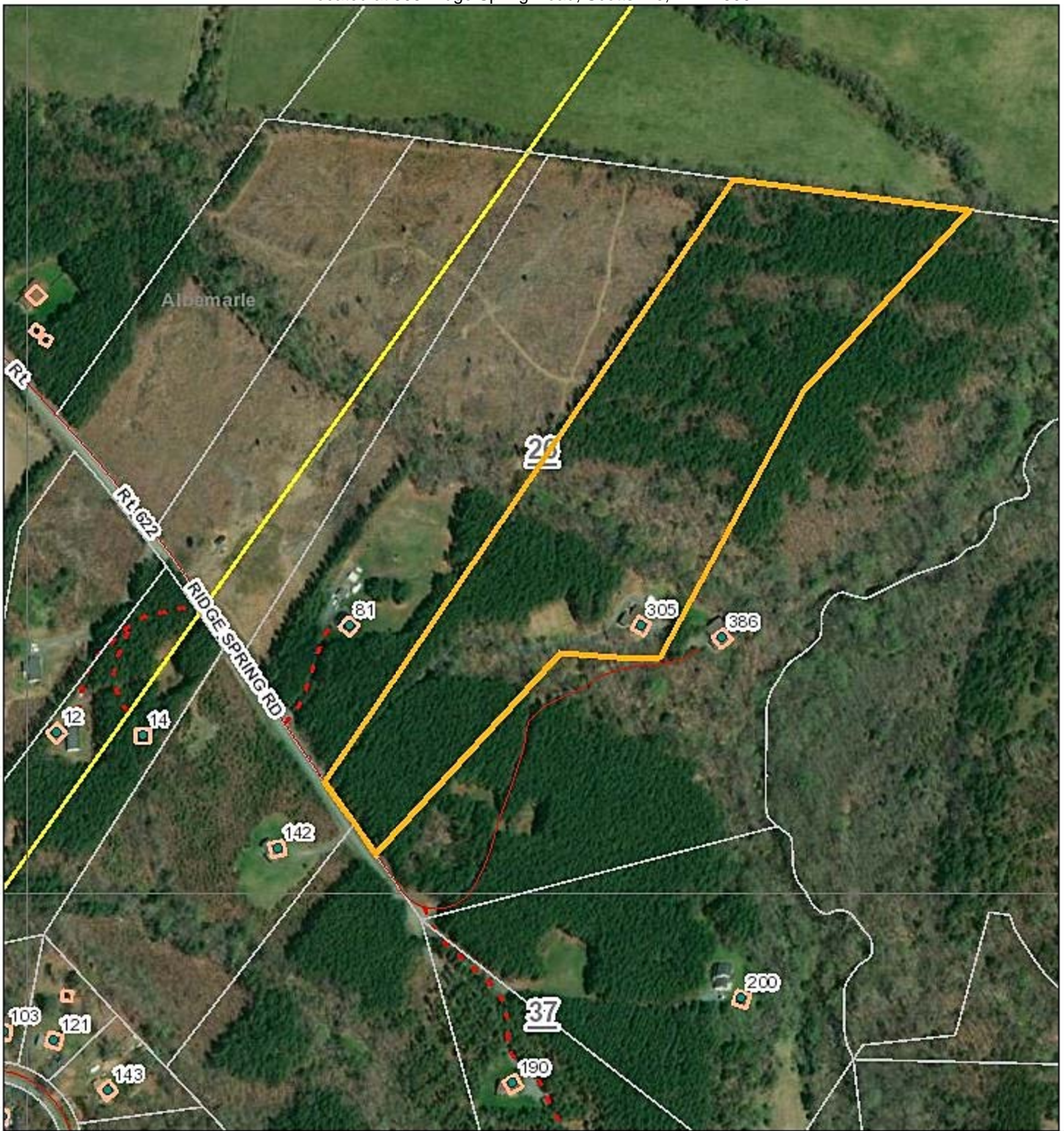

November 13, 2018

1:5,266

- | | | |
|------------------|-----------------------|------------------------|
| ● Address Points | ● Place Names | □ Surrounding Counties |
| Roads | — Town Boundary | □ Address Point Labels |
| — Interstate | + Railroads | Road Labels |
| — Primary | - - Driveways | — Interstate |
| — Secondary | □ Building Footprints | — Primary |
| — Other | □ Tax Map Grid | — Secondary |
| □ Parcels | □ County Boundary | — Other |

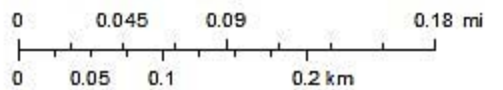

Source: Esri, DigitalGlobe, GeoEye, Earthstar Geographics, CNES/Airbus DS, USDA, USGS, AeroGRID, IGN, and the GIS User Community

**FLUVANNA COUNTY BOARD OF SUPERVISORS
AGENDA ITEM STAFF REPORT**

TAB G

MEETING DATE:	November 20, 2018				
AGENDA TITLE:	Approval of Open Space Contract for Linda H. & Charles Michael Payne				
MOTION(s):	I move to approve the open space contract for Linda H. & Charles Michael Payne for tax map parcel 31-A-34; agreement shall remain in effect for a term of fifteen (15) consecutive years.				
STRATEGIC INITIATIVE?	Yes	No	If yes, list initiative(s):		
		X			
AGENDA CATEGORY:	Public Hearing	Action Matter	Presentation	Consent Agenda	Other
				X	
STAFF CONTACT(S):	Andrew M. Sheridan, Jr., Commissioner of the Revenue				
PRESENTER(S):	Andrew M. Sheridan, Jr., Commissioner of the Revenue				
RECOMMENDATION:	Approval				
TIMING:	Immediate				
DISCUSSION:	This property qualifies for an open space contract with Fluvanna County in accordance with Code Section 58.1-3229 et. seq. of the Virginia State Code.				
FISCAL IMPACT:	None				
POLICY IMPACT:	In accordance with Section 58.1-3229 et. seq. of Virginia State Code.				
LEGISLATIVE HISTORY:	N/A				
ENCLOSURES:	-Linda H. & Charles Michael Payne's executed open space contract -Map of tax map parcel 31-A-34				
REVIEWS COMPLETED:	Legal	Finance	Purchasing	HR	Other



CONTRACT FOR OPEN SPACE LAND USE ASSESSMENT

THIS AGREEMENT, made this 27th day of September, 2018, by and between Linda H. & Charles Michael Payne, party(ies) of the first part, hereinafter called the Grantor, and the COUNTY OF FLUVANNA, a political subdivision of the Commonwealth of Virginia, party of the second part, hereinafter called the County:

WITNESSETH

WHEREAS, the Grantor owns certain real estate, described below, hereinafter called the Property; and

WHEREAS, the County is the local governing body having real estate tax jurisdiction over the Property; and

WHEREAS, the County has determined:

- A. That it is in the public interest that the Property should be provided or preserved for conservation of agricultural and forestal land and of wildlife and
- B. That the property meets ~~the~~ applicable criteria for real estate devoted to open-space use as prescribed in Article 4 (Section 58.1-3229 et. seq.) of Chapter 32 of Title 58.1 of the Code of Virginia, and the standards for classifying such real estate prescribed by the Director of the Virginia Department of Conservation and Recreation; and
- C. That the provisions of this agreement meet the requirements and standards prescribed under section 58.1-3233 of the Code of Virginia for recorded commitments by landowners not to change an open-space use to a non-qualifying use; and

WHEREAS, the Grantor is willing to make a written recorded commitment to preserve and protect the open-space uses of the Property during the term of this agreement in order for the Property to be taxed on the basis of a use assessment, and the Grantor has submitted an application for such taxation to the Commissioner of the Revenue of the County pursuant to Section 58.1-3234 of the Code of Virginia and Section 20-4-2(d) of the Fluvanna County Code; and

WHEREAS, the County is willing to extend the tax for the Property on the basis of a use assessment commencing with the next succeeding tax year and continuing for the term of this agreement, in consideration of the Grantor's commitment to preserve and protect the open-space uses of the property, and on the condition that the Grantor's application is satisfactory and that all other requirements of Article 4, Chapter 32, Title 58.1 of the Code of Virginia and Section 20-4-2(d) of the Fluvanna County Code are complied with.

NOW, THEREFORE, in consideration of the recital and the mutual benefits, covenants and terms herein contained, the parties hereby **COVENANT** and **AGREE** as follows:

1. This agreement shall apply to all the following described real estate:

Tax Map Parcel: 31-A-34 (16.41 acres)

2. The Grantor agrees that during the term of this agreement:
 - A. There shall be no change in the use or uses of the Property that exist as of the date of this agreement to any use that would not qualify as open-space use. The qualifying use for the Property is conservation of agricultural and forestal land and of wildlife.
 - B. There shall be no display of billboards, signs or other advertisements on the property except to (i) state solely the name of the Grantor and the address of the Property, (ii) advertise the sale or lease of the Property, ~~(iii)~~ advertise the sale of goods or services produced pursuant to the permitted use of the Property, or (iv) provide warnings. No sign shall exceed four feet by four feet.
 - C. There shall be no construction, placement or maintenance of any structure on the Property unless such structure is either:
 - 1) on the Property as of the date of this agreement; or
 - 2) related to and compatible with the open-space uses of the Property which this agreement is intended to protect or provide for.
 - D. There shall be no dumping or storage of trash, garbage, ashes, waste, junk, abandoned property or other unsightly or offensive material on the Property.
 - E. There shall be no filling, excavating, mining, drilling, removal of topsoil, sand, gravel, rock, minerals, or other materials which alters the topography of the Property, except as required in the construction of permissible building structures and features under this agreement.

- F. There shall be no construction or placement of fences, screens, hedges, walls or other similar barriers which materially obstruct the public view of scenic areas of the Property.
 - G. The Grantor may engage in agricultural, horticultural or silvicultural activities and remove vegetation which constitutes a safety, a health or an ecological hazard, e.g., vegetation classified as noxious weed pursuant the Code of Virginia (1950), as amended.
 - H. There shall be no alteration or manipulation of natural water courses, shores, marshes, swamps, wetlands or other water bodies, nor any activities or uses which adversely affect water quality, level or flow.
 - I. On areas of the Property that are being provided or preserved for conservation of land, floodways or other natural resources, or that are to be left in a relatively natural or undeveloped state, there shall be no operation of dune buggies, all-terrain vehicles, motorcycles, motorbikes, snowmobiles or other motor vehicles, except to the extent necessary to inspect, protect or preserve the area.
 - J. There shall be no industrial or commercial activities, conducted on the property, except for the continuation of agricultural, horticultural or silvicultural activities; or activities that are conducted in a residence or an associated outbuilding such as garage, smokehouse, small shop or similar structure which is permitted on the property.
 - K. There shall be no separation or split-off of lots, pieces or parcels from the property. The Property may be sold or transferred during the term of this agreement only as the same entire parcel that is the subject to this agreement, provided, however, that the Grantor may grant to a public body or bodies open-space, conservation or historic preservation easements which apply to all or part of the Property.
3. This agreement shall be effective upon acceptance by the County, provided, however, that the real estate tax for the Property shall not be extended on the basis of its use value until the next succeeding tax year following timely application by the Grantor for the use assessment and taxation in accordance with Section 20-4-2(d) of the Fluvanna County Code. Thereafter, this agreement shall remain in effect for a terms of 15 () consecutive years.

4. Nothing contained herein shall be construed as giving to the public a right to enter upon or to use the Property or any portion thereof, except as the Grantor may otherwise allow, consistent with the provisions of this agreement.
5. The County shall have the right at all reasonable times to enter the Property to determine whether the Grantor is complying with the provisions of this agreement.
6. Nothing in this agreement shall be construed to create in the public or member thereof a right to maintain a suit for any damages against the Grantor for any violation of this agreement.
7. Nothing in this agreement shall be construed to permit Grantor to conduct any activity or to build or maintain any improvement which is otherwise prohibited by law.
8. If any provision of this agreement is determined to be invalid by a court of competent jurisdiction, the remainder of the agreement shall not be affected thereby.
9. The provisions of this agreement shall run with the land and be binding upon the parties, their successors, assigns, personal representatives, and heirs.
10. Words of one gender used herein shall include the other gender, and words in the singular shall include words in the plural, whenever the sense requires.
11. This agreement may be terminated in the manner provided in Section 15.1-1513 of the Code of Virginia for withdrawal of land from an agricultural, forestal or an agricultural and forestal district.
12. Upon termination of this agreement, the Property shall thereafter be assessed and taxed at its fair market value, regardless of its actual use, unless the County determines otherwise in accordance with applicable law.
13. NOTICE: WHEN THE OPEN SPACE USE OR USES BY WHICH THE PROPERTY QUALIFIED FOR ASSESSMENT AND TAXATION ON THE BASIS OF USE CHANGES TO A NONQUALIFYING USE OR USES, OR WHEN THE ZONING FOR THE PROPERTY CHANGES TO A MORE INTENSIVE USE AT THE REQUEST OF THE GRANTOR, THE PROPERTY, OR SUCH PORTION OF THE PROPERTY WHICH NO LONGER QUALIFIES SHALL BE SUBJECT TO ROLLBACK TAXES IN ACCORDANCE WITH SECTION 58.1-3237 OF THE CODE OF VIRGINIA. THE GRANTOR SHALL BE SUBJECT TO ALL OF THE OBLIGATIONS AND LIABILITIES OF SAID CODES SECTION.

Linda Payne (SEAL)
Landowner

Charles Michael Payne (SEAL)
Co-owner (s)

**STATE OF VIRGINIA
COUNTY OF FLUVANNA, to-wit:**

The foregoing instrument was acknowledged before me by

Linda Payne & Charles Michael Payne Landowner (s)

on this 27th day of September, 2018.

My commission expires: January 31, 2019

Diane D Gunsallus
Notary Public

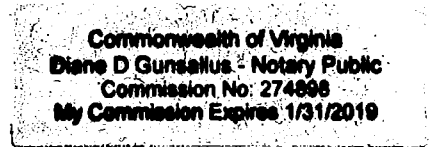

COUNTY OF FLUVANNA, VIRGINIA

By: _____
County Administrator

**STATE OF VIRGINIA
COUNTY OF FLUVANNA, to-wit:**

The foregoing instrument was acknowledged before me by

_____, Fluvanna County Administrator

on this _____ day of _____, _____.

My commission expires: _____

Notary Public

Fluvanna County, VA WebGIS Parcels - PIN: 31A34

BOS 2016-11-20 p.364/421

Located off of Miles Jackson Road in Palmyra, VA 22963

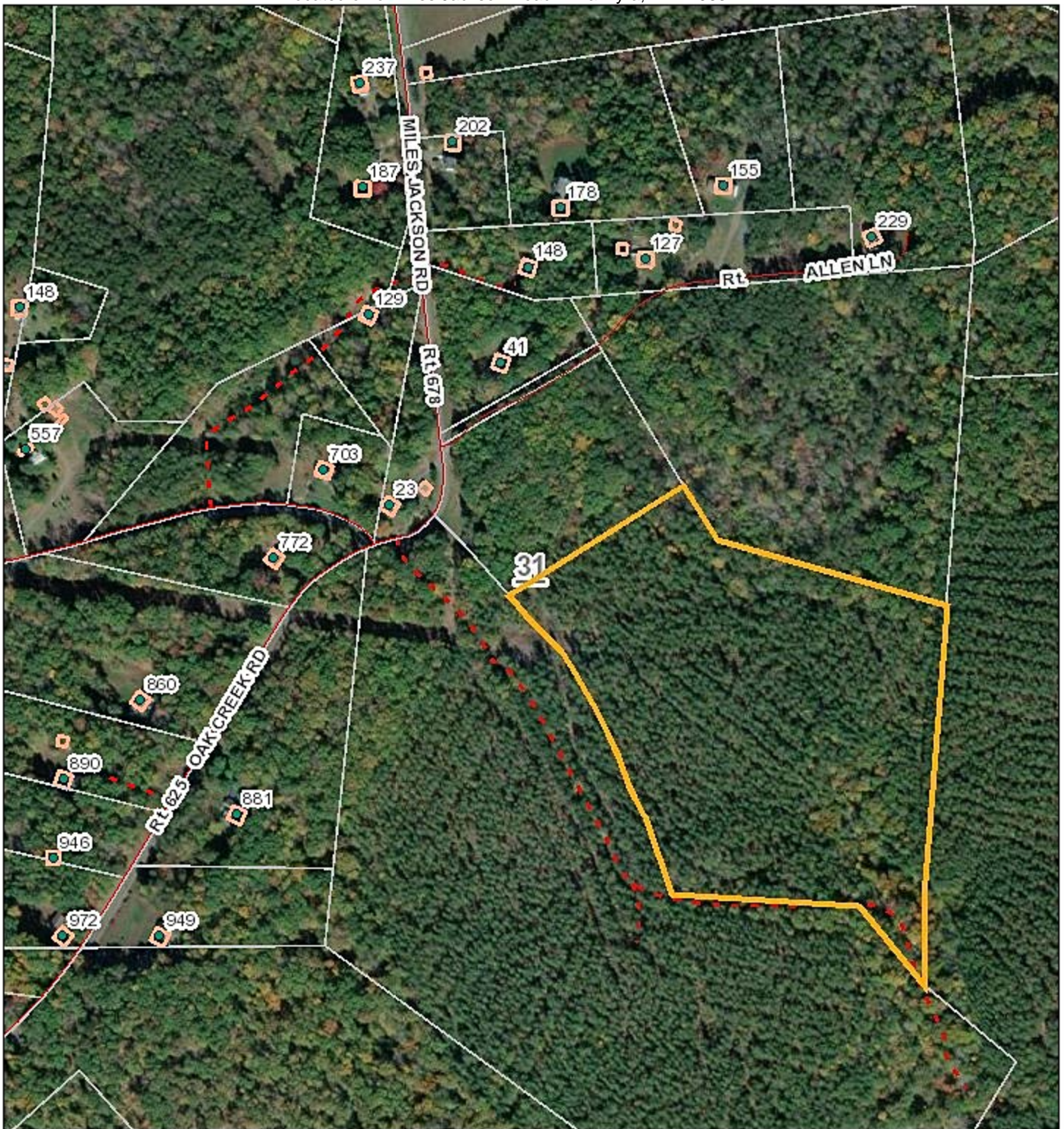

November 13, 2018

1:5,266

- | | | |
|----------------|---------------------|----------------------|
| Address Points | Place Names | Surrounding Counties |
| Roads | Town Boundary | Address Point Labels |
| Interstate | Railroads | Road Labels |
| Primary | Driveways | Interstate |
| Secondary | Building Footprints | Primary |
| Other | Tax Map Grid | Secondary |
| Parcels | County Boundary | Other |

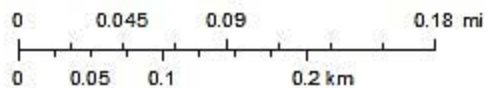

Source: Esri, DigitalGlobe, GeoEye, Earthstar Geographics, CNES/Airbus DS, USDA, USGS, AeroGRID, IGN, and the GIS User Community

**FLUVANNA COUNTY BOARD OF SUPERVISORS
AGENDA ITEM STAFF REPORT**

TAB H

MEETING DATE:	November 20, 2018				
AGENDA TITLE:	Approval of Open Space Contract for Travis & Stacey Rittenhouse				
MOTION(s):	I move to approve the open space contract for Travis & Stacey Rittenhouse for tax map parcels 38-9-A & 38-9-B; agreement shall remain in effect for a term of five (5) consecutive years.				
STRATEGIC INITIATIVE?	Yes	No	If yes, list initiative(s):		
		X			
AGENDA CATEGORY:	Public Hearing	Action Matter	Presentation	Consent Agenda	Other
				X	
STAFF CONTACT(S):	Andrew M. Sheridan, Jr., Commissioner of the Revenue				
PRESENTER(S):	Andrew M. Sheridan, Jr., Commissioner of the Revenue				
RECOMMENDATION:	Approval				
TIMING:	Immediate				
DISCUSSION:	These properties qualify for an open space contract with Fluvanna County in accordance with Code Section 58.1-3229 et. seq. of the Virginia State Code.				
FISCAL IMPACT:	None				
POLICY IMPACT:	In accordance with Section 58.1-3229 et. seq. of Virginia State Code.				
LEGISLATIVE HISTORY:	N/A				
ENCLOSURES:	-Travis & Stacey Rittenhouse's executed open space contract -Map of tax map parcels 38-9-A & 38-9-B				
REVIEWS COMPLETED:	Legal	Finance	Purchasing	HR	Other



CONTRACT FOR OPEN SPACE LAND USE ASSESSMENT

THIS AGREEMENT, made this 26 day of September, 2018, by and between Travis & Stacey Rittenhouse, party(ies) of the first part, hereinafter called the Grantor, and the COUNTY OF FLUVANNA, a political subdivision of the Commonwealth of Virginia, party of the second part, hereinafter called the County:

WITNESSETH

WHEREAS, the Grantor owns certain real estate, described below, hereinafter called the Property; and

WHEREAS, the County is the local governing body having real estate tax jurisdiction over the Property; and

WHEREAS, the County has determined:

- A. That it is in the public interest that the Property should be provided or preserved for conservation of agricultural and forestal land and of wildlife and
- B. That the property meets the applicable criteria for real estate devoted to open-space use as prescribed in Article 4 (Section 58.1-3229 et. seq.) of Chapter 32 of Title 58.1 of the Code of Virginia, and the standards for classifying such real estate prescribed by the Director of the Virginia Department of Conservation and Recreation; and
- C. That the provisions of this agreement meet the requirements and standards prescribed under section 58.1-3233 of the Code of Virginia for recorded commitments by landowners not to change an open-space use to a non-qualifying use; and

WHEREAS, the Grantor is willing to make a written recorded commitment to preserve and protect the open-space uses of the Property during the term of this agreement in order for the Property to be taxed on the basis of a use assessment, and the Grantor has submitted an application for such taxation to the Commissioner of the Revenue of the County pursuant to Section 58.1-3234 of the Code of Virginia and Section 20-4-2(d) of the Fluvanna County Code; and

WHEREAS, the County is willing to extend the tax for the Property on the basis of a use assessment commencing with the next succeeding tax year and continuing for the term of this agreement, in consideration of the Grantor's commitment to preserve and protect the open-space uses of the property, and on the condition that the Grantor's application is satisfactory and that all other requirements of Article 4, Chapter 32, Title 58.1 of the Code of Virginia and Section 20-4-2(d) of the Fluvanna County Code are complied with.

NOW, THEREFORE, in consideration of the recital and the mutual benefits, covenants and terms herein contained, the parties hereby **COVENANT** and **AGREE** as follows:

1. This agreement shall apply to all the following described real estate:

Tax Map Parcels: 38-9-A (15.89 acres)

38-9-B (8.0 acres)

Total Acreage: 23.89 acres

2. The Grantor agrees that during the term of this agreement:
 - A. There shall be no change in the use or uses of the Property that exist as of the date of this agreement to any use that would not qualify as open-space use. The qualifying use for the Property is conservation of agricultural and forestal land and of wildlife.
 - B. There shall be no display of billboards, signs or other advertisements on the property except to (i) state solely the name of the Grantor and the address of the Property, (ii) advertise the sale or lease of the Property, (iii) advertise the sale of goods or services produced pursuant to the permitted use of the Property, or (iv) provide warnings. No sign shall exceed four feet by four feet.
 - C. There shall be no construction, placement or maintenance of any structure on the Property unless such structure is either:
 - 1) on the Property as of the date of this agreement; or
 - 2) related to and compatible with the open-space uses of the Property which this agreement is intended to protect or provide for.
 - D. There shall be no dumping or storage of trash, garbage, ashes, waste, junk, abandoned property or other unsightly or offensive material on the Property.
 - E. There shall be no filling, excavating, mining, drilling, removal of topsoil, sand, gravel, rock, minerals, or other materials which alters the topography of the Property, except as required in the construction of permissible building structures and features under this agreement.

- F. There shall be no construction or placement of fences, screens, hedges, walls or other similar barriers which materially obstruct the public view of scenic areas of the Property.
 - G. The Grantor may engage in agricultural, horticultural or silvicultural activities and remove vegetation which constitutes a safety, a health or an ecological hazard, e.g., vegetation classified as noxious weed pursuant the Code of Virginia (1950), as amended.
 - H. There shall be no alteration or manipulation of natural water courses, shores, marshes, swamps, wetlands or other water bodies, nor any activities or uses which adversely affect water quality, level or flow.
 - I. On areas of the Property that are being provided or preserved for conservation of land, floodways or other natural resources, or that are to be left in a relatively natural or undeveloped state, there shall be no operation of dune buggies, all-terrain vehicles, motorcycles, motorbikes, snowmobiles or other motor vehicles, except to the extent necessary to inspect, protect or preserve the area.
 - J. There shall be no industrial or commercial activities, conducted on the property, except for the continuation of agricultural, horticultural or silvicultural activities; or activities that are conducted in a residence or an associated outbuilding such as garage, smokehouse, small shop or similar structure which is permitted on the property.
 - K. There shall be no separation or split-off of lots, pieces or parcels from the property. The Property may be sold or transferred during the term of this agreement only as the same entire parcel that is the subject to this agreement, provided, however, that the Grantor may grant to a public body or bodies open-space, conservation or historic preservation easements which apply to all or part of the Property.
3. This agreement shall be effective upon acceptance by the County, provided, however, that the real estate tax for the Property shall not be extended on the basis of its use value until the next succeeding tax year following timely application by the Grantor for the use assessment and taxation in accordance with Section 20-4-2(d) of the Fluvanna County Code. Thereafter, this agreement shall remain in effect for a terms of Five (5) consecutive years.

4. Nothing contained herein shall be construed as giving to the public a right to enter upon or to use the Property or any portion thereof, except as the Grantor may otherwise allow, consistent with the provisions of this agreement.
5. The County shall have the right at all reasonable times to enter the Property to determine whether the Grantor is complying with the provisions of this agreement.
6. Nothing in this agreement shall be construed to create in the public or member thereof a right to maintain a suit for any damages against the Grantor for any violation of this agreement.
7. Nothing in this agreement shall be construed to permit Grantor to conduct any activity or to build or maintain any improvement which is otherwise prohibited by law.
8. If any provision of this agreement is determined to be invalid by a court of competent jurisdiction, the remainder of the agreement shall not be affected thereby.
9. The provisions of this agreement shall run with the land and be binding upon the parties, their successors, assigns, personal representatives, and heirs.
10. Words of one gender used herein shall include the other gender, and words in the singular shall include words in the plural, whenever the sense requires.
11. This agreement may be terminated in the manner provided in Section 15.1-1513 of the Code of Virginia for withdrawal of land from an agricultural, forestal or an agricultural and forestal district.
12. Upon termination of this agreement, the Property shall thereafter be assessed and taxed at its fair market value, regardless of its actual use, unless the County determines otherwise in accordance with applicable law.
13. NOTICE: WHEN THE OPEN SPACE USE OR USES BY WHICH THE PROPERTY QUALIFIED FOR ASSESSMENT AND TAXATION ON THE BASIS OF USE CHANGES TO A NONQUALIFYING USE OR USES, OR WHEN THE ZONING FOR THE PROPERTY CHANGES TO A MORE INTENSIVE USE AT THE REQUEST OF THE GRANTOR, THE PROPERTY, OR SUCH PORTION OF THE PROPERTY WHICH NO LONGER QUALIFIES SHALL BE SUBJECT TO ROLLBACK TAXES IN ACCORDANCE WITH SECTION 58.1-3237 OF THE CODE OF VIRGINIA. THE GRANTOR SHALL BE SUBJECT TO ALL OF THE OBLIGATIONS AND LIABILITIES OF SAID CODES SECTION.

[Signature] (SEAL)
Landowner

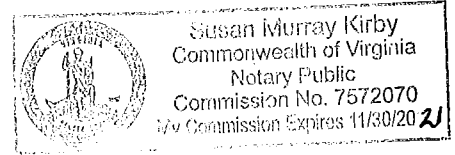

Stacey E. R. Huhauer (SEAL)
Co-owner (s)

September 27, 2018
My Commission Expires November 30, 2021
Susan Murray Kirby

STATE OF VIRGINIA
COUNTY OF FLUVANNA, to-wit:

The foregoing instrument was acknowledged before me by

Travis Rittenhouse, Landowner (s)

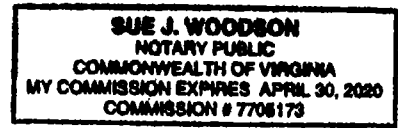

on this 26th day of September, 2018.

My commission expires: April 30, 2020

Sue J. Woodson
Notary Public

COUNTY OF FLUVANNA, VIRGINIA

By: _____
County Administrator

STATE OF VIRGINIA
COUNTY OF FLUVANNA, to-wit:

The foregoing instrument was acknowledged before me by

_____, Fluvanna County Administrator

on this _____ day of _____, _____.

My commission expires: _____

Notary Public

Fluvanna County, VA WebGIS Parcels - PIN:38-9-A & 38-9-B

Located at 631 Suncrest Drive, Scottsville, VA 24590

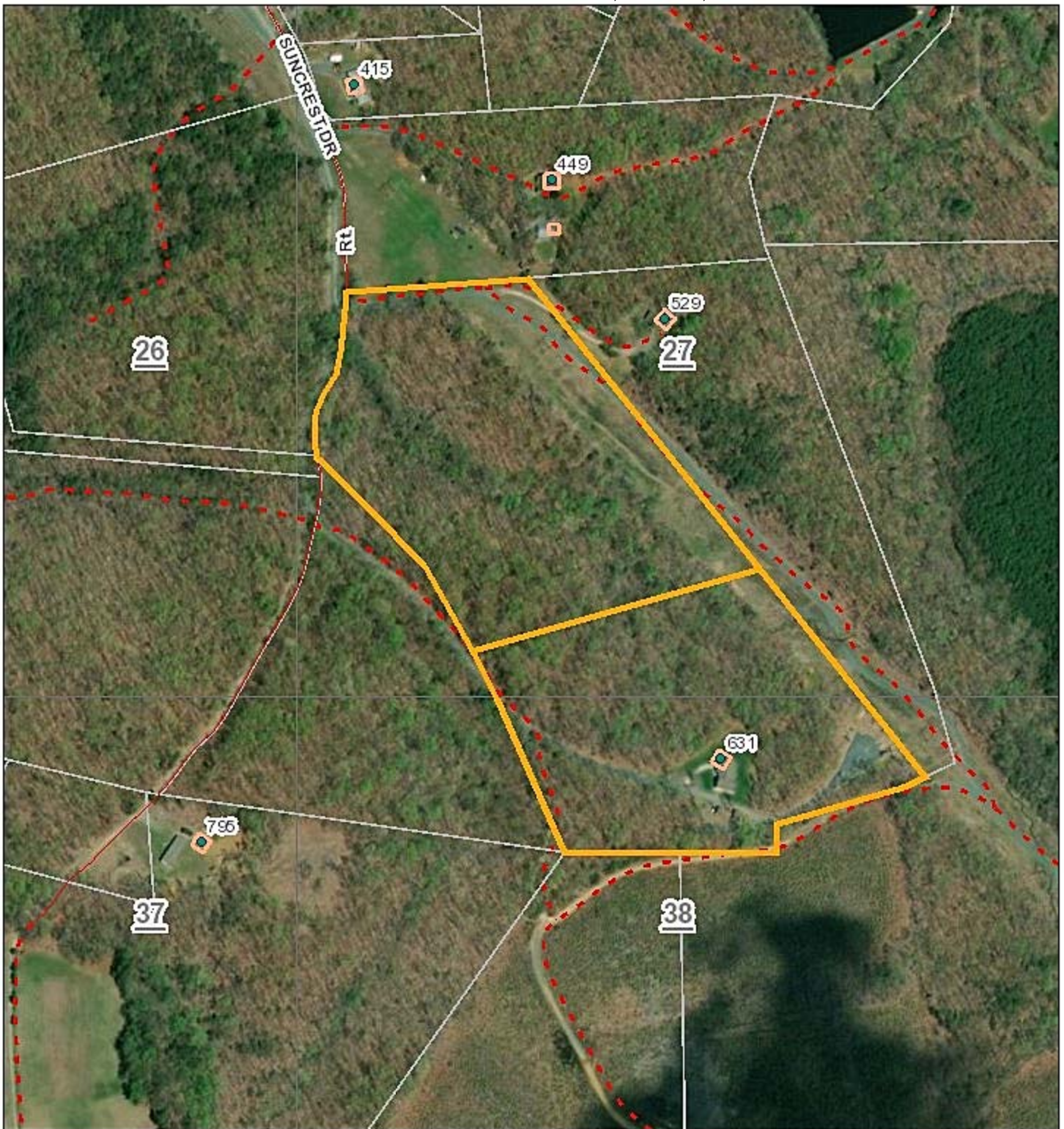

November 13, 2018

1:5,266

- | | | |
|------------------|-----------------------|------------------------|
| ● Address Points | ● Place Names | □ Surrounding Counties |
| Roads | — Town Boundary | □ Address Point Labels |
| — Interstate | + Railroads | Road Labels |
| — Primary | - - Driveways | — Interstate |
| — Secondary | □ Building Footprints | — Primary |
| — Other | □ Tax Map Grid | — Secondary |
| □ Parcels | □ County Boundary | — Other |

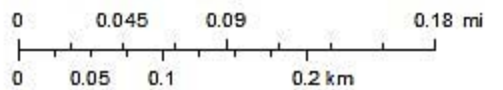

Source: Esri, DigitalGlobe, GeoEye, Earthstar Geographics, CNES/Airbus DS, USDA, USGS, AeroGRID, IGN, and the GIS User Community

**FLUVANNA COUNTY BOARD OF SUPERVISORS
AGENDA ITEM STAFF REPORT**

TAB I

MEETING DATE:	November 20, 2018				
AGENDA TITLE:	Approval of Open Space Contract Renewal for Susan Harvey Dawson				
MOTION(s):	I move to approve the open space contract for Susan Harvey Dawson for tax map parcel 14-6-5; agreement shall remain in effect for a term of fifteen (15) consecutive years.				
STRATEGIC INITIATIVE?	Yes	No	If yes, list initiative(s):		
		X			
AGENDA CATEGORY:	Public Hearing	Action Matter	Presentation	Consent Agenda	Other
				X	
STAFF CONTACT(S):	Andrew M. Sheridan, Jr., Commissioner of the Revenue				
PRESENTER(S):	Andrew M. Sheridan, Jr., Commissioner of the Revenue				
RECOMMENDATION:	Approval				
TIMING:	Immediate				
DISCUSSION:	This property qualifies for an open space contract with Fluvanna County in accordance with Code Section 58.1-3229 et. seq. of the Virginia State Code.				
FISCAL IMPACT:	None				
POLICY IMPACT:	In accordance with Section 58.1-3229 et. seq. of Virginia State Code.				
LEGISLATIVE HISTORY:	N/A				
ENCLOSURES:	-Susan Harvey Dawson's executed open space contract -Map of tax map parcel 14-6-5				
REVIEWS COMPLETED:	Legal	Finance	Purchasing	HR	Other



CONTRACT FOR OPEN SPACE LAND USE ASSESSMENT

THIS AGREEMENT, made this 6TH day of SEPTEMBER 2018, by and between Susan Harvey Dawson, party(ies) of the first part, hereinafter called the Grantor, and the COUNTY OF FLUVANNA, a political subdivision of the Commonwealth of Virginia, party of the second part, hereinafter called the County:

WITNESSETH

WHEREAS, the Grantor owns certain real estate, described below, hereinafter called the Property; and

WHEREAS, the County is the local governing body having real estate tax jurisdiction over the Property; and

WHEREAS, the County has determined:

- A. That it is in the public interest that the Property should be provided or preserved for conservation of agricultural and forestal land and of wildlife and
- B. That the property meets the applicable criteria for real estate devoted to open-space use as prescribed in Article 4 (Section 58.1-3229 et. seq.) of Chapter 32 of Title 58.1 of the Code of Virginia, and the standards for classifying such real estate prescribed by the Director of the Virginia Department of Conservation and Recreation; and
- C. That the provisions of this agreement meet the requirements and standards prescribed under section 58.1-3233 of the Code of Virginia for recorded commitments by landowners not to change an open-space use to a non-qualifying use; and

WHEREAS, the Grantor is willing to make a written recorded commitment to preserve and protect the open-space uses of the Property during the term of this agreement in order for the Property to be taxed on the basis of a use assessment, and the Grantor has submitted an application for such taxation to the Commissioner of the Revenue of the County pursuant to Section 58.1-3234 of the Code of Virginia and Section 20-4-2(d) of the Fluvanna County Code; and

WHEREAS, the County is willing to extend the tax for the Property on the basis of a use assessment commencing with the next succeeding tax year and continuing for the term of this agreement, in consideration of the Grantor's commitment to preserve and protect the open-space uses of the property, and on the condition that the Grantor's application is satisfactory and that all other requirements of Article 4, Chapter 32, Title 58.1 of the Code of Virginia and Section 20-4-2(d) of the Fluvanna County Code are complied with.

NOW, THEREFORE, in consideration of the recital and the mutual benefits, covenants and terms herein contained, the parties hereby **COVENANT** and **AGREE** as follows:

1. This agreement shall apply to all the following described real estate:

Tax Map Parcels: 14-6-5 (10.534 acres)

2. The Grantor agrees that during the term of this agreement:
 - A. There shall be no change in the use or uses of the Property that exist as of the date of this agreement to any use that would not qualify as open-space use. The qualifying use for the Property is conservation of agricultural and forestal land and of wildlife.
 - B. There shall be no display of billboards, signs or other advertisements on the property except to (i) state solely the name of the Grantor and the address of the Property, (ii) advertise the sale or lease of the Property, (iii) advertise the sale of goods or services produced pursuant to the permitted use of the Property, or (iv) provide warnings. No sign shall exceed four feet by four feet.
 - C. There shall be no construction, placement or maintenance of any structure on the Property unless such structure is either:
 - 1) on the Property as of the date of this agreement; or
 - 2) related to and compatible with the open-space uses of the Property which this agreement is intended to protect or provide for.
 - D. There shall be no dumping or storage of trash, garbage, ashes, waste, junk, abandoned property or other unsightly or offensive material on the Property.
 - E. There shall be no filling, excavating, mining, drilling, removal of topsoil, sand, gravel, rock, minerals, or other materials which alters the topography of the Property, except as required in the construction of permissible building structures and features under this agreement.

- F. There shall be no construction or placement of fences, screens, hedges, walls or other similar barriers which materially obstruct the public view of scenic areas of the Property.
 - G. The Grantor may engage in agricultural, horticultural or silvicultural activities and remove vegetation which constitutes a safety, a health or an ecological hazard, e.g., vegetation classified as noxious weed pursuant the Code of Virginia (1950), as amended.
 - H. There shall be no alteration or manipulation of natural water courses, shores, marshes, swamps, wetlands or other water bodies; nor any activities or uses which adversely affect water quality, level or flow.
 - I. On areas of the Property that are being provided or preserved for conservation of land, floodways or other natural resources, or that are to be left in a relatively natural or undeveloped state, there shall be no operation of dune buggies, all-terrain vehicles, motorcycles, motorbikes, snowmobiles or other motor vehicles, except to the extent necessary to inspect, protect or preserve the area.
 - J. There shall be no industrial or commercial activities, conducted on the property, except for the continuation of agricultural, horticultural or silvicultural activities; or activities that are conducted in a residence or an associated outbuilding such as garage, smokehouse, small shop or similar structure which is permitted on the property.
 - K. There shall be no separation or split-off of lots, pieces or parcels from the property. The Property may be sold or transferred during the term of this agreement only as the same entire parcel that is the subject to this agreement, provided, however, that the Grantor may grant to a public body or bodies open-space, conservation or historic preservation easements which apply to all or part of the Property.
3. This agreement shall be effective upon acceptance by the County, provided, however, that the real estate tax for the Property shall not be extended on the basis of its use value until the next succeeding tax year following timely application by the Grantor for the use assessment and taxation in accordance with Section 20-4-2(d) of the Fluvanna County Code. Thereafter, this agreement shall remain in effect for a terms of FIFTEEN (15) consecutive years.

4. Nothing contained herein shall be construed as giving to the public a right to enter upon or to use the Property or any portion thereof, except as the Grantor may otherwise allow, consistent with the provisions of this agreement.
5. The County shall have the right at all reasonable times to enter the Property to determine whether the Grantor is complying with the provisions of this agreement.
6. Nothing in this agreement shall be construed to create in the public or member thereof a right to maintain a suit for any damages against the Grantor for any violation of this agreement.
7. Nothing in this agreement shall be construed to permit Grantor to conduct any activity or to build or maintain any improvement which is otherwise prohibited by law.
8. If any provision of this agreement is determined to be invalid by a court of competent jurisdiction, the remainder of the agreement shall not be affected thereby.
9. The provisions of this agreement shall run with the land and be binding upon the parties, their successors, assigns, personal representatives, and heirs.
10. Words of one gender used herein shall include the other gender, and words in the singular shall include words in the plural, whenever the sense requires.
11. This agreement may be terminated in the manner provided in Section 15.1-1513 of the Code of Virginia for withdrawal of land from an agricultural, forestal or an agricultural and forestal district.
12. Upon termination of this agreement, the Property shall thereafter be assessed and taxed at its fair market value, regardless of its actual use, unless the County determines otherwise in accordance with applicable law.
13. NOTICE: WHEN THE OPEN SPACE USE OR USES BY WHICH THE PROPERTY QUALIFIED FOR ASSESSMENT AND TAXATION ON THE BASIS OF USE CHANGES TO A NONQUALIFYING USE OR USES, OR WHEN THE ZONING FOR THE PROPERTY CHANGES TO A MORE INTENSIVE USE AT THE REQUEST OF THE GRANTOR, THE PROPERTY, OR SUCH PORTION OF THE PROPERTY WHICH NO LONGER QUALIFIES SHALL BE SUBJECT TO ROLLBACK TAXES IN ACCORDANCE WITH SECTION 58.1-3237 OF THE CODE OF VIRGINIA. THE GRANTOR SHALL BE SUBJECT TO ALL OF THE OBLIGATIONS AND LIABILITIES OF SAID CODES SECTION.

Susan H Dawson (SEAL)
Landowner

N/A (SEAL)
Co-owner (s)

**STATE OF VIRGINIA
COUNTY OF FLUVANNA, to-wit:**

The foregoing instrument was acknowledged before me by

SUSAN H DAWSON, Landowner (s)

on this 6th day of September, 2018.

My commission expires: 3/31/2019



Notary Public, Virginia
Commonwealth at Large
Jolyn S. Bullock
ID# 280647
My Commission Expires 3/31/2019

Jolyn S. Bullock
Notary Public

COUNTY OF FLUVANNA, VIRGINIA

By: _____
County Administrator

**STATE OF VIRGINIA
COUNTY OF FLUVANNA, to-wit:**

The foregoing instrument was acknowledged before me by

_____, Fluvanna County Administrator

on this _____ day of _____, _____.

My commission expires: _____

Notary Public

Fluvanna County, VA WebGIS Parcels - PIN: 1465

Located at 85 Ferncliff Farms Lane, Kents Store, VA 23084

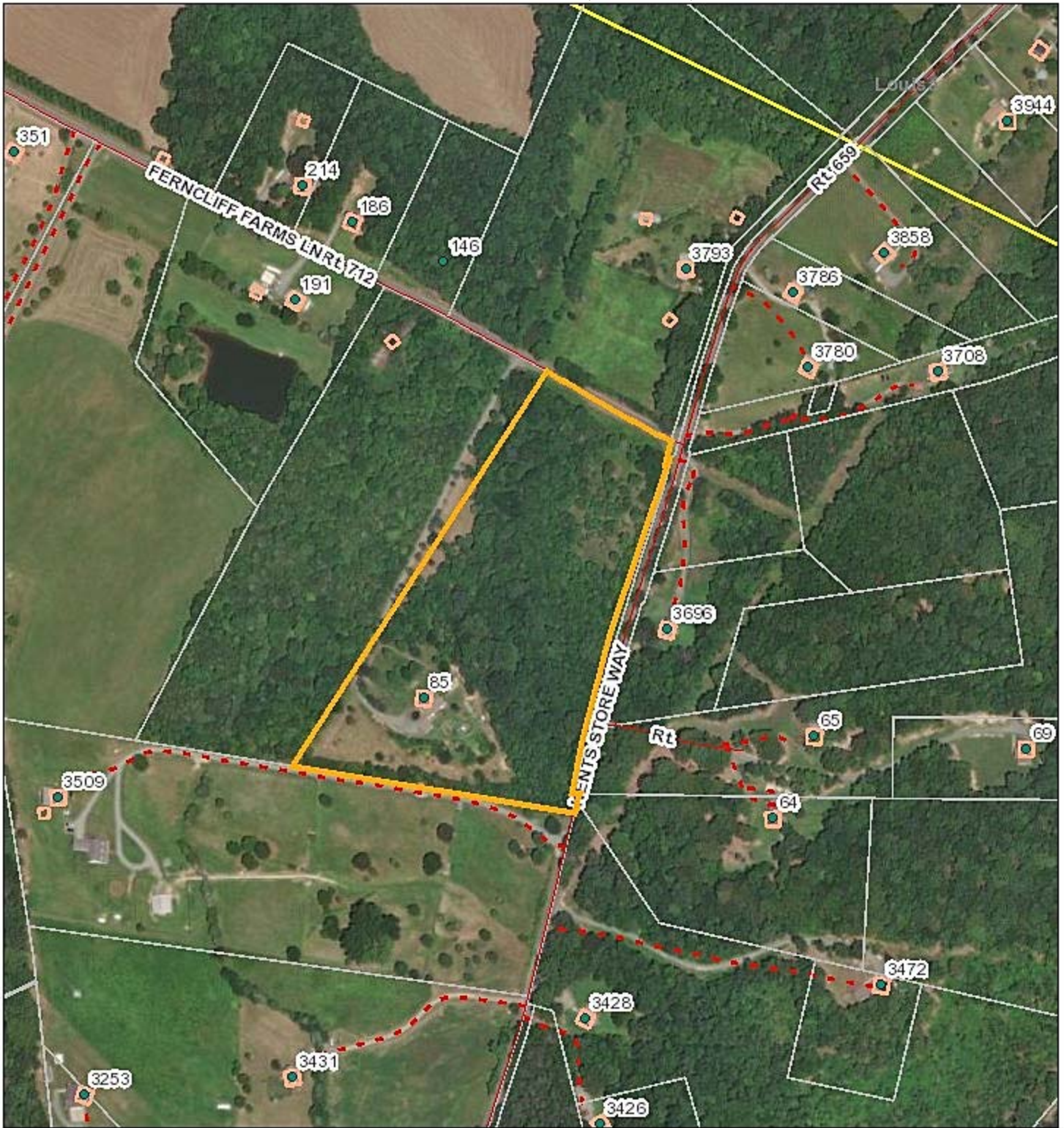

November 13, 2018

1:5,266

- | | | |
|------------------|-----------------------|------------------------|
| ● Address Points | ● Place Names | □ Surrounding Counties |
| Roads | — Town Boundary | □ Address Point Labels |
| — Interstate | + Railroads | Road Labels |
| — Primary | - - Driveways | — Interstate |
| — Secondary | □ Building Footprints | — Primary |
| — Other | □ Tax Map Grid | — Secondary |
| □ Parcels | □ County Boundary | — Other |

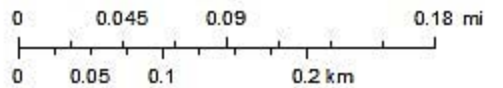

Source: Esri, DigitalGlobe, GeoEye, Earthstar Geographics, CNES/Airbus DS, USDA, USGS, AeroGRID, IGN, and the GIS User Community

**FLUVANNA COUNTY BOARD OF SUPERVISORS
AGENDA ITEM STAFF REPORT**

TAB J

MEETING DATE:	November 20, 2018				
AGENDA TITLE:	Approval of Open Space Contract Renewal for Matthew L. Dickey				
MOTION(s):	I move to approve the open space contract for Matthew L. Dickey for tax map parcel 56-1-6; agreement shall remain in effect for a term of five (5) consecutive years.				
STRATEGIC INITIATIVE?	Yes	No	If yes, list initiative(s):		
		X			
AGENDA CATEGORY:	Public Hearing	Action Matter	Presentation	Consent Agenda	Other
				X	
STAFF CONTACT(S):	Andrew M. Sheridan, Jr., Commissioner of the Revenue				
PRESENTER(S):	Andrew M. Sheridan, Jr., Commissioner of the Revenue				
RECOMMENDATION:	Approval				
TIMING:	Immediate				
DISCUSSION:	This property qualifies for an open space contract with Fluvanna County in accordance with Code Section 58.1-3229 et. seq. of the Virginia State Code.				
FISCAL IMPACT:	None				
POLICY IMPACT:	In accordance with Section 58.1-3229 et. seq. of Virginia State Code.				
LEGISLATIVE HISTORY:	N/A				
ENCLOSURES:	-Matthew L. Dickey's executed open space contract -Map of tax map parcel 56-1-6				
REVIEWS COMPLETED:	Legal	Finance	Purchasing	HR	Other



CONTRACT FOR OPEN SPACE LAND USE ASSESSMENT

THIS AGREEMENT, made this 10th day of SEPTEMBER, 2018, by and between Matthew L. Dickey, party(ies) of the first part, hereinafter called the Grantor, and the COUNTY OF FLUVANNA, a political subdivision of the Commonwealth of Virginia, party of the second part, hereinafter called the County:

WITNESSETH

WHEREAS, the Grantor owns certain real estate, described below, hereinafter called the Property; and

WHEREAS, the County is the local governing body having real estate tax jurisdiction over the Property; and

WHEREAS, the County has determined:

- A. That it is in the public interest that the Property should be provided or preserved for conservation of agricultural and forestal land and of wildlife and
- B. That the property meets the applicable criteria for real estate devoted to open-space use as prescribed in Article 4 (Section 58.1-3229 et. seq.) of Chapter 32 of Title 58.1 of the Code of Virginia, and the standards for classifying such real estate prescribed by the Director of the Virginia Department of Conservation and Recreation; and
- C. That the provisions of this agreement meet the requirements and standards prescribed under section 58.1-3233 of the Code of Virginia for recorded commitments by landowners not to change an open-space use to a non-qualifying use; and

WHEREAS, the Grantor is willing to make a written recorded commitment to preserve and protect the open-space uses of the Property during the term of this agreement in order for the Property to be taxed on the basis of a use assessment, and the Grantor has submitted an application for such taxation to the Commissioner of the Revenue of the County pursuant to Section 58.1-3234 of the Code of Virginia and Section 20-4-2(d) of the Fluvanna County Code; and

WHEREAS, the County is willing to extend the tax for the Property on the basis of a use assessment commencing with the next succeeding tax year and continuing for the term of this agreement, in consideration of the Grantor's commitment to preserve and protect the open-space uses of the property, and on the condition that the Grantor's application is satisfactory and that all other requirements of Article 4, Chapter 32, Title 58.1 of the Code of Virginia and Section 20-4-2(d) of the Fluvanna County Code are complied with.

NOW, THEREFORE, in consideration of the recital and the mutual benefits, covenants and terms herein contained, the parties hereby **COVENANT** and **AGREE** as follows:

1. This agreement shall apply to all the following described real estate:

Tax Map Parcels: 56-1-6 (19.35 acres)

2. The Grantor agrees that during the term of this agreement:
 - A. There shall be no change in the use or uses of the Property that exist as of the date of this agreement to any use that would not qualify as open-space use. The qualifying use for the Property is conservation of agricultural and forestal land and of wildlife.
 - B. There shall be no display of billboards, signs or other advertisements on the property except to (i) state solely the name of the Grantor and the address of the Property, (ii) advertise the sale or lease of the Property, (iii) advertise the sale of goods or services produced pursuant to the permitted use of the Property, or (iv) provide warnings. No sign shall exceed four feet by four feet.
 - C. There shall be no construction, placement or maintenance of any structure on the Property unless such structure is either:
 - 1) on the Property as of the date of this agreement; or
 - 2) related to and compatible with the open-space uses of the Property which this agreement is intended to protect or provide for.
 - D. There shall be no dumping or storage of trash, garbage, ashes, waste, junk, abandoned property or other unsightly or offensive material on the Property.
 - E. There shall be no filling, excavating, mining, drilling, removal of topsoil, sand, gravel, rock, minerals, or other materials which alters the topography of the Property, except as required in the construction of permissible building structures and features under this agreement.

- F. There shall be no construction or placement of fences, screens, hedges, walls or other similar barriers which materially obstruct the public view of scenic areas of the Property.
 - G. The Grantor may engage in agricultural, horticultural or silvicultural activities and remove vegetation which constitutes a safety, a health or an ecological hazard, e.g., vegetation classified as noxious weed pursuant the Code of Virginia (1950), as amended.
 - H. There shall be no alteration or manipulation of natural water courses, shores, marshes, swamps, wetlands or other water bodies, nor any activities or uses which adversely affect water quality, level or flow.
 - I. On areas of the Property that are being provided or preserved for conservation of land, floodways or other natural resources, or that are to be left in a relatively natural or undeveloped state, there shall be no operation of dune buggies, all-terrain vehicles, motorcycles, motorbikes, snowmobiles or other motor vehicles, except to the extent necessary to inspect, protect or preserve the area.
 - J. There shall be no industrial or commercial activities, conducted on the property, except for the continuation of agricultural, horticultural or silvicultural activities; or activities that are conducted in a residence or an associated outbuilding such as garage, smokehouse, small shop or similar structure which is permitted on the property.
 - K. There shall be no separation or split-off of lots, pieces or parcels from the property. The Property may be sold or transferred during the term of this agreement only as the same entire parcel that is the subject to this agreement, provided, however, that the Grantor may grant to a public body or bodies open-space, conservation or historic preservation easements which apply to all or part of the Property.
3. This agreement shall be effective upon acceptance by the County, provided, however, that the real estate tax for the Property shall not be extended on the basis of its use value until the next succeeding tax year following timely application by the Grantor for the use assessment and taxation in accordance with Section 20-4-2(d) of the Fluvanna County Code. Thereafter, this agreement shall remain in effect for a terms of five (5) consecutive years.

4. Nothing contained herein shall be construed as giving to the public a right to enter upon or to use the Property or any portion thereof, except as the Grantor may otherwise allow, consistent with the provisions of this agreement.
5. The County shall have the right at all reasonable times to enter the Property to determine whether the Grantor is complying with the provisions of this agreement.
6. Nothing in this agreement shall be construed to create in the public or member thereof a right to maintain a suit for any damages against the Grantor for any violation of this agreement.
7. Nothing in this agreement shall be construed to permit Grantor to conduct any activity or to build or maintain any improvement which is otherwise prohibited by law.
8. If any provision of this agreement is determined to be invalid by a court of competent jurisdiction, the remainder of the agreement shall not be affected thereby.
9. The provisions of this agreement shall run with the land and be binding upon the parties, their successors, assigns, personal representatives, and heirs.
10. Words of one gender used herein shall include the other gender, and words in the singular shall include words in the plural, whenever the sense requires.
11. This agreement may be terminated in the manner provided in Section 15.1-1513 of the Code of Virginia for withdrawal of land from an agricultural, forestal or an agricultural and forestal district.
12. Upon termination of this agreement, the Property shall thereafter be assessed and taxed at its fair market value, regardless of its actual use, unless the County determines otherwise in accordance with applicable law.
13. NOTICE: WHEN THE OPEN SPACE USE OR USES BY WHICH THE PROPERTY QUALIFIED FOR ASSESSMENT AND TAXATION ON THE BASIS OF USE CHANGES TO A NONQUALIFYING USE OR USES, OR WHEN THE ZONING FOR THE PROPERTY CHANGES TO A MORE INTENSIVE USE AT THE REQUEST OF THE GRANTOR, THE PROPERTY, OR SUCH PORTION OF THE PROPERTY WHICH NO LONGER QUALIFIES SHALL BE SUBJECT TO ROLLBACK TAXES IN ACCORDANCE WITH SECTION 58.1-3237 OF THE CODE OF VIRGINIA. THE GRANTOR SHALL BE SUBJECT TO ALL OF THE OBLIGATIONS AND LIABILITIES OF SAID CODES SECTION.

Sam Dickey for Matthew Dickey (P.O.A.)
Landowner (SEAL)



Co-owner (s) (SEAL)

**STATE OF VIRGINIA
COUNTY OF FLUVANNA, to-wit:**

The foregoing instrument was acknowledged before me by

Sam Dickey, POA for Matthew Dickey, Landowner (s)
on this 10th day of September, 2018.

My commission expires: 3/31/2022

Lauren R. Sheridan
Notary Public

COUNTY OF FLUVANNA, VIRGINIA

By: _____
County Administrator

**STATE OF VIRGINIA
COUNTY OF FLUVANNA, to-wit:**

The foregoing instrument was acknowledged before me by

_____, Fluvanna County Administrator

on this _____ day of _____, _____.

My commission expires: _____

Notary Public

Fluvanna County, VA WebGIS Parcels - PIN: 5610

BO# 2018-11-20 p.388/421

Located at 206 Hardware River Drive, Scottsville, VA 24590



November 13, 2018

1:5,266

- | | | |
|------------------|-----------------------|------------------------|
| ● Address Points | ● Place Names | □ Surrounding Counties |
| Roads | --- Town Boundary | □ Address Point Labels |
| — Interstate | + Railroads | Road Labels |
| — Primary | - - - Driveways | — Interstate |
| — Secondary | □ Building Footprints | — Primary |
| — Other | □ Tax Map Grid | — Secondary |
| □ Parcels | □ County Boundary | — Other |

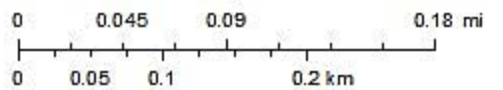

Source: Esri, DigitalGlobe, GeoEye, Earthstar Geographics, CNES/Airbus DS, USDA, USGS, AeroGRID, IGN, and the GIS User Community

**FLUVANNA COUNTY BOARD OF SUPERVISORS
AGENDA ITEM STAFF REPORT**

TAB K

MEETING DATE:	November 20, 2018				
AGENDA TITLE:	Approval of Open Space Contract Renewal for Janet M. Grubbs				
MOTION(s):	I move to approve the open space contract for Janet M. Grubbs for tax map parcels 14-A-20A, 14-8-2 & 14-8-3; agreement shall remain in effect for a term of five (5) consecutive years.				
STRATEGIC INITIATIVE?	Yes	No	If yes, list initiative(s):		
		X			
AGENDA CATEGORY:	Public Hearing	Action Matter	Presentation	Consent Agenda	Other
				X	
STAFF CONTACT(S):	Andrew M. Sheridan, Jr., Commissioner of the Revenue				
PRESENTER(S):	Andrew M. Sheridan, Jr., Commissioner of the Revenue				
RECOMMENDATION:	Approval				
TIMING:	Immediate				
DISCUSSION:	These properties qualify for an open space contract with Fluvanna County in accordance with Code Section 58.1-3229 et. seq. of the Virginia State Code.				
FISCAL IMPACT:	None				
POLICY IMPACT:	In accordance with Section 58.1-3229 et. seq. of Virginia State Code.				
LEGISLATIVE HISTORY:	N/A				
ENCLOSURES:	-Janet M. Grubb's executed open space contract -Map of tax map parcels 14-A-20A, 14-8-2 & 14-8-3				
REVIEWS COMPLETED:	Legal	Finance	Purchasing	HR	Other



CONTRACT FOR OPEN SPACE LAND USE ASSESSMENT

THIS AGREEMENT, made this 18 day of October, ~~2018~~, by and between Janet M. Grubbs, party(ies) of the first part, hereinafter called the Grantor, and the COUNTY OF FLUVANNA, a political subdivision of the Commonwealth of Virginia, party of the second part, hereinafter called the County:

WITNESSETH

WHEREAS, the Grantor owns certain real estate, described below, hereinafter called the Property; and

WHEREAS, the County is the local governing body having real estate tax jurisdiction over the Property; and

WHEREAS, the County has determined:

- A. That it is in the public interest that the Property should be provided or preserved for conservation of agricultural and forestal land and of wildlife and
- B. That the property meets the applicable criteria for real estate devoted to open-space use as prescribed in Article 4 (Section 58.1-3229 et. seq.) of Chapter 32 of Title 58.1 of the Code of Virginia, and the standards for classifying such real estate prescribed by the Director of the Virginia Department of Conservation and Recreation; and
- C. That the provisions of this agreement meet the requirements and standards prescribed under section 58.1-3233 of the Code of Virginia for recorded commitments by landowners not to change an open-space use to a non-qualifying use; and

WHEREAS, the Grantor is willing to make a written recorded commitment to preserve and protect the open-space uses of the Property during the term of this agreement in order for the Property to be taxed on the basis of a use assessment, and the Grantor has submitted an application for such taxation to the Commissioner of the Revenue of the County pursuant to Section 58.1-3234 of the Code of Virginia and Section 20-4-2(d) of the Fluvanna County Code; and

WHEREAS, the County is willing to extend the tax for the Property on the basis of a use assessment commencing with the next succeeding tax year and continuing for the term of this agreement, in consideration of the Grantor's commitment to preserve and protect the open-space uses of the property, and on the condition that the Grantor's application is satisfactory and that all other requirements of Article 4, Chapter 32, Title 58.1 of the Code of Virginia and Section 20-4-2(d) of the Fluvanna County Code are complied with.

NOW, THEREFORE, in consideration of the recital and the mutual benefits, covenants and terms herein contained, the parties hereby **COVENANT** and **AGREE** as follows:

1. This agreement shall apply to all the following described real estate:

Tax Map Parcels: 14-A-20A (10.0 acres)
 14-8-2 (13.614 acres)
 14-8-3 (10.857 acres)
 Total Acreage: 34.471 acres

2. The Grantor agrees that during the term of this agreement:

- A. There shall be no change in the use or uses of the Property that exist as of the date of this agreement to any use that would not qualify as open-space use. The qualifying use for the Property is conservation of agricultural and forestal land and of wildlife.
- B. There shall be no display of billboards, signs or other advertisements on the property except to (i) state solely the name of the Grantor and the address of the Property, (ii) advertise the sale or lease of the Property, (iii) advertise the sale of goods or services produced pursuant to the permitted use of the Property, or (iv) provide warnings. No sign shall exceed four feet by four feet.
- C. There shall be no construction, placement or maintenance of any structure on the Property unless such structure is either:
 - 1) on the Property as of the date of this agreement; or
 - 2) related to and compatible with the open-space uses of the Property which this agreement is intended to protect or provide for.
- D. There shall be no dumping or storage of trash, garbage, ashes, waste, junk, abandoned property or other unsightly or offensive material on the Property.
- E. There shall be no filling, excavating, mining, drilling, removal of topsoil, sand, gravel, rock, minerals, or other materials which alters the topography of the Property, except as required in the construction of permissible building structures and features under this agreement.

- F. There shall be no construction or placement of fences, screens, hedges, walls or other similar barriers which materially obstruct the public view of scenic areas of the Property.
 - G. The Grantor may engage in agricultural, horticultural or silvicultural activities and remove vegetation which constitutes a safety, a health or an ecological hazard, e.g., vegetation classified as noxious weed pursuant the Code of Virginia (1950), as amended.
 - H. There shall be no alteration or manipulation of natural water courses, shores, marshes, swamps, wetlands or other water bodies, nor any activities or uses which adversely affect water quality, level or flow.
 - I. On areas of the Property that are being provided or preserved for conservation of land, floodways or other natural resources, or that are to be left in a relatively natural or undeveloped state, there shall be no operation of dune buggies, all-terrain vehicles, motorcycles, motorbikes, snowmobiles or other motor vehicles, except to the extent necessary to inspect, protect or preserve the area.
 - J. There shall be no industrial or commercial activities, conducted on the property, except for the continuation of agricultural, horticultural or silvicultural activities; or activities that are conducted in a residence or an associated outbuilding such as garage, smokehouse, small shop or similar structure which is permitted on the property.
 - K. There shall be no separation or split-off of lots, pieces or parcels from the property. The Property may be sold or transferred during the term of this agreement only as the same entire parcel that is the subject to this agreement, provided, however, that the Grantor may grant to a public body or bodies open-space, conservation or historic preservation easements which apply to all or part of the Property.
3. This agreement shall be effective upon acceptance by the County, provided, however, that the real estate tax for the Property shall not be extended on the basis of its use value until the next succeeding tax year following timely application by the Grantor for the use assessment and taxation in accordance with Section 20-4-2(d) of the Fluvanna County Code. Thereafter, this agreement shall remain in effect for a terms of three five (5) consecutive years.

J.H.

4. Nothing contained herein shall be construed as giving to the public a right to enter upon or to use the Property or any portion thereof, except as the Grantor may otherwise allow, consistent with the provisions of this agreement.
5. The County shall have the right at all reasonable times to enter the Property to determine whether the Grantor is complying with the provisions of this agreement.
6. Nothing in this agreement shall be construed to create in the public or member thereof a right to maintain a suit for any damages against the Grantor for any violation of this agreement.
7. Nothing in this agreement shall be construed to permit Grantor to conduct any activity or to build or maintain any improvement which is otherwise prohibited by law.
8. If any provision of this agreement is determined to be invalid by a court of competent jurisdiction, the remainder of the agreement shall not be affected thereby.
9. The provisions of this agreement shall run with the land and be binding upon the parties, their successors, assigns, personal representatives, and heirs.
10. Words of one gender used herein shall include the other gender, and words in the singular shall include words in the plural, whenever the sense requires.
11. This agreement may be terminated in the manner provided in Section 15.1-1513 of the Code of Virginia for withdrawal of land from an agricultural, forestal or an agricultural and forestal district.
12. Upon termination of this agreement, the Property shall thereafter be assessed and taxed at its fair market value, regardless of its actual use, unless the County determines otherwise in accordance with applicable law.
13. NOTICE: WHEN THE OPEN SPACE USE OR USES BY WHICH THE PROPERTY QUALIFIED FOR ASSESSMENT AND TAXATION ON THE BASIS OF USE CHANGES TO A NONQUALIFYING USE OR USES, OR WHEN THE ZONING FOR THE PROPERTY CHANGES TO A MORE INTENSIVE USE AT THE REQUEST OF THE GRANTOR, THE PROPERTY, OR SUCH PORTION OF THE PROPERTY WHICH NO LONGER QUALIFIES SHALL BE SUBJECT TO ROLLBACK TAXES IN ACCORDANCE WITH SECTION 58.1-3237 OF THE CODE OF VIRGINIA. THE GRANTOR SHALL BE SUBJECT TO ALL OF THE OBLIGATIONS AND LIABILITIES OF SAID CODES SECTION.

Janet Grubb (Green) (SEAL)
Landowner

Co-owner (s) (SEAL)

**STATE OF VIRGINIA
COUNTY OF FLUVANNA, to-wit:**

The foregoing instrument was acknowledged before me by

Janet M Grubbs, Landowner (s)
on this 19 day of October, 2018.

My commission expires: 12/31/18

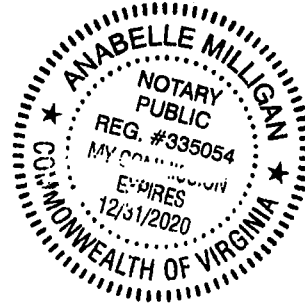

[Signature]
Notary Public

COUNTY OF FLUVANNA, VIRGINIA

By: _____
County Administrator

**STATE OF VIRGINIA
COUNTY OF FLUVANNA, to-wit:**

The foregoing instrument was acknowledged before me by

_____, Fluvanna County Administrator

on this _____ day of _____, _____.

My commission expires: _____

Notary Public

Fluvanna County, VA WebGIS Parcels - PIN: 14-A-20A, 14-8-2 & 14-8-3

Located off of Campout Lane in Kents Store, VA 23084

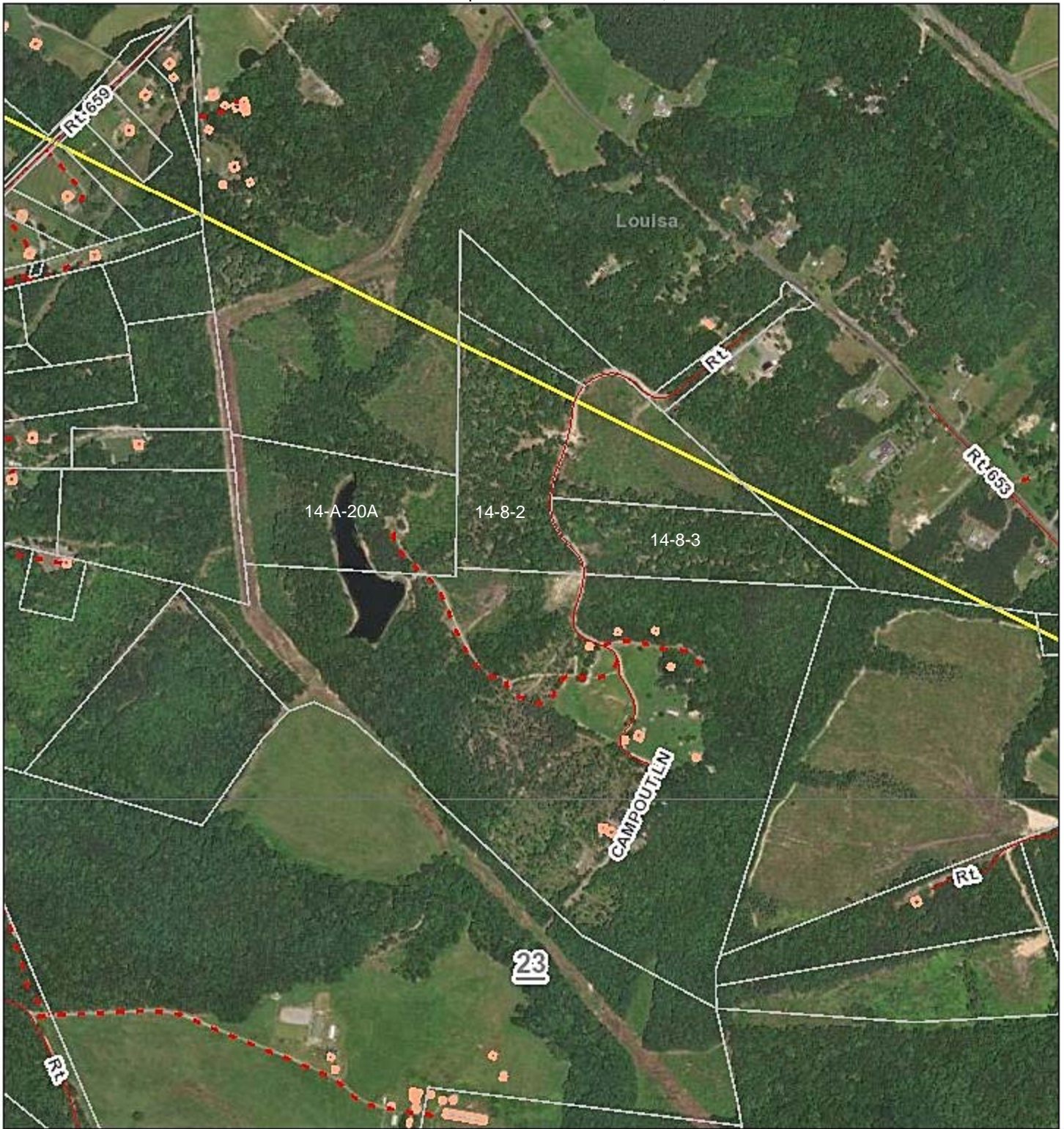

November 13, 2018

1:10,533

- | | | |
|----------------|---------------------|----------------------|
| Address Points | Place Names | Surrounding Counties |
| Roads | Town Boundary | Address Point Labels |
| Interstate | Railroads | Road Labels |
| Primary | Driveways | Interstate |
| Secondary | Building Footprints | Primary |
| Other | Tax Map Grid | Secondary |
| Parcels | County Boundary | Other |

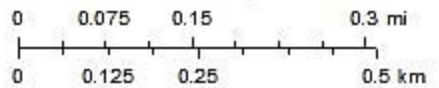

Source: Esri, DigitalGlobe, GeoEye, Earthstar Geographics, CNES/Airbus DS, USDA, USGS, AeroGRID, IGN, and the GIS User Community

**FLUVANNA COUNTY BOARD OF SUPERVISORS
AGENDA ITEM STAFF REPORT**

TAB L

MEETING DATE:	November 20, 2018				
AGENDA TITLE:	Position Description – Assistant Public Works Director				
MOTION(s):	I move to approve the revised Position Description 3680, Assistant Public Works Director, as presented.				
STRATEGIC INITIATIVE?	Yes	No	If yes, list initiative(s):		
		x			
AGENDA CATEGORY:	Public Hearing	Action Matter	Presentation	Consent Agenda	Other
				x	
STAFF CONTACT(S):	Jessica Rice, HR Manager, and Steve Nichols, County Administrator				
PRESENTER(S):	Jessica Rice, HR Manager				
RECOMMENDATION:	Approval				
TIMING:	Current				
DISCUSSION:	This is a minor revision and update to the existing Assistant Public Works Director Position Description. No change in pay band.				
FISCAL IMPACT:	No change to position grade; costs within current budget.				
POLICY IMPACT:	N/A				
LEGISLATIVE HISTORY:	N/A				
ENCLOSURES:	New and Old Position Descriptions				
REVIEWS COMPLETED:	Legal	Finance	Purchasing	HR	Other
				x	



Fluvanna County, Virginia
Department of Public Works
Job Description

ASSISTANT PUBLIC WORKS DIRECTOR / PROJECT MANAGER

Job Class #:	3680
Pay Grade:	19
Category:	Full-Time (with benefits)
FLSA Status:	Exempt
Reports To:	Public Works Director

SUMMARY

The Public Works Department employs professional, skilled labor, and general labor positions in the following functional areas: Water and Wastewater; Irrigation; Roads; Solid Waste and Recycling; Building and Grounds Maintenance; Custodial Services; and Project Management.

Under general supervision of the Public Works Director, the Assistant Director performs Project Management duties and will provide direction, management, and oversight to the Building and Grounds Maintenance and Custodial Service areas, as well as small tenant improvement and remodel projects. Responsible for preparing written and verbal technical reports to the Public Works Director and external agencies, as required. The successful candidate will also assist the Department Director in general oversight of the entire Department by assisting with personnel issues, budgeting, long range planning, development of strategic initiatives, and representation on various boards and committees. May be called to respond for emergency situations, including weather and other building emergencies.

ESSENTIAL FUNCTIONS

- Oversees, manages, and supervises day-to-day operations and maintenance of building systems, custodial, and grounds, and project management and construction of facility improvements. Acts on behalf of the Public Works Director by assignment or delegation in the director's absence.
- Assists in the design and coordination of complex public works projects; provides technical assistance as required. Conducts short and long-range facilities management planning and identifies specific space and equipment needs to support future requirements. Establishes schedules for all projects and work requests; monitors work progress. Implements and maintains a comprehensive energy conservation and safety program.
- Establishes performance standards for facility preventative and regular maintenance activities including response times to work requests, time to completion, and work quality. Develops and oversees programs to measure performance and manage and track facilities maintenance issues. Works with assigned supervisors to evaluate effectiveness of standards and work methods, and takes necessary corrective action for improvements. Conducts periodic site visits to evaluate work quality to ensure compliance with applicable safety guidelines, building codes, and federal, state, and county regulations.
- Establishes systems to identify, track, and maintain status records on Community facilities in need of maintenance, remodeling, renovation, and repairs. Ensures availability of necessary budget, supplies, personnel, and equipment to support facility improvement projects, maintenance, repairs, and custodial services. Creates and maintains technical specifications for the purchase of goods and services related to facilities maintenance and repair.

- Provides leadership and training to assigned staff; plans, prioritizes, assigns, coordinates, schedules and reviews work of staff. Evaluates work of subordinates and conducts performance appraisals in a timely manner. Develops standard procedures to guide subordinates in their areas of responsibility. Assists in maintaining department-level employee records. Responds to staff questions regarding assignments. Oversees preparation, accuracy, and timely submittal of staff work time via time keeping system. Monitors staff effectiveness and recognizes achievements as well as corrects deficiencies in performance.
- Assists in the preparation, coordination, and control of the operating and capital improvement budgets for the Department. Monitors annual facilities modification/maintenance budgets to ensure that spending remains within established parameters. Accounts for and oversees all payment of funds to vendors, consultants, contractors, and sub-contractors used in completing work projects. Coordinates and contracts outside skilled labor when needs cannot be met with in-house staff in order to maintain project budgets and meet project deadlines.
- Reviews plans and specifications and makes facilities management recommendations for operations, maintenance, and upkeep of new facilities and major engineering projects prior to and during construction. Assists the Public Works Director in the contract preparation and negotiations with outside contractors and consultants on the design and construction of improvement projects.
- Coordinates Facilities Management activities with various committees, commissions, public utilities agencies, and other appropriate governmental organizations. Provides staff support to appropriate committees and commissions, as directed by the Publics Works Director.
- Analyze and assist in designing and developing departmental work processes, operations, and construction project approaches to continuously address effective and efficient service delivery.
- Develop, recommend, revise, and enforce organizational and departmental standard operating procedures including County policies, and safety rules and regulations.
- Participate and make recommendations in personnel matters including, but not limited to, interviewing and selecting employees, appraising productivity and efficiency of employees, reviewing performance evaluations completed by division managers for their subordinates and offering advice and assistance when necessary; and handling employee complaints.
- Coordinate with the Finance Department to maintain a competitive purchasing process.
- Provide ongoing administration and oversight of various County contracts and agreements for which the Department is responsible.
- Assist with the development, implementation, administration, and enforcement of departmental emergency operation, policies, and procedures.
- Administer a comprehensive program of required and discretionary safety and skills enhancement and professional development training and other related activities.
- Performs other job related duties as assigned to maintain and enhance departmental and agency operations.

REQUIRED KNOWLEDGE, SKILLS AND ABILITIES

Knowledge of:

- Trends, development issues, and theories of technical project management to include project management programs, software, delivery systems and reporting processes;
- Design and construction processes and techniques used by architectural and engineering firms;
- Material and techniques of construction projects;
- Government planning process;
- Management practices;
- Math and surveying methods;
- Principles and practices of engineering and/or utility operations;
- Principles and practices of program development and administration;
- Office procedures, methods, and equipment including computers and applicable software applications;

- Principles and practices of municipal budget preparation and administration;
- Principles of supervision, training and performance evaluation;
- Modern office procedures, methods and equipment including computers;
- Pertinent federal, state and local laws, codes and regulations.

Skills:

- Project and Program Management;
- Giving full attention to what other people are saying, taking time to understand the points being made, asking questions as appropriate, and not interrupting at inappropriate times;
- Leading teams and facilitating groups;
- Analyze problems, identify alternative solutions, predict consequences of proposed actions and implement recommendations in support of goals;
- Managing one's own time and the time of others.

Abilities:

- To select qualified design professionals;
- To manage construction to deliver the project from planning, through bidding, construction and close out on time and on budget;
- To supervise supervisory and line staff;
- To communicate effectively, both orally and in writing;
- To establish and maintain effective working relationships with employees, department heads, County officials, and representatives from the private sector or other jurisdictions, and the public;
- To oversee, direct and coordinate the work of lower level staff;
- To select, supervise, train and evaluate staff;
- To participate in the development and administration of department goals, objectives and procedures;
- To interpret and apply federal, state and local policies, laws and regulations;
- To prepare clear and concise administrative and project reports;
- To communicate clearly and concisely, both orally and in writing;
- To establish and maintain effective working relationships with those contacted in the course of work.

ACCEPTABLE EDUCATION, EXPERIENCE, AND TRAINING

- Education, training and/or work experience equivalent to a Bachelor's degree from an accredited college or university with major course work in engineering, public administration, business administration or a related field.
- Five years of increasingly responsible public works experience including two years of administrative and supervisory responsibility.
- Any equivalent combination of experience and education that will allow the applicant to satisfactorily perform the duties of the job may be considered when filling the position.

WORKING CONDITIONS AND PHYSICAL REQUIREMENTS

- Required to carry a cell phone and subject to recall at any time during an emergency and may be required to work long hours without normal days off.
- Must be able to travel in personal or assigned vehicle to emergency scenes, meetings, or public events in order to complete office assignments.
- Must be able to respond independently or as directed at odd hours and for extended periods of time during emergencies.
- Must be available to work some weekends and evenings for presentations, training, and meetings.
- Office environment exposure to computer screens; sitting for prolonged periods of time.

- Ability to work indoors/outdoors under adverse conditions for an extended period of time in the event of an emergency.
- Must have ability to occasionally lift, push/pull, and hold/carry 30 pounds.
- Must have the ability to frequently stand and sit, and occasionally walk over flat and uneven terrain.

SPECIAL REQUIREMENTS

- Must possess and maintain an appropriate driver's license valid in the Commonwealth of Virginia.

POST OFFER REQUIREMENTS

- Criminal background check and driving record check.

Department Head Recommended:	HR Manager Approval as to Form:	County Administrator Recommended:	Board of Supervisors Approved:
3/20/13	3/20/13	3/20/13	April 3, 2013



Fluvanna County, Virginia
Department of Public Works
Job Description

ASSISTANT PUBLIC WORKS DIRECTOR

Job Class #:	3680
Pay Grade:	19
Category:	Full-Time (with benefits)
FLSA Status:	Exempt
Reports To:	Public Works Director

SUMMARY

The Public Works Department employs professional, skilled labor, and general labor positions in the functional areas of: Building and Grounds Maintenance; Custodial Services; Water and Wastewater; Irrigation; Roads; Solid Waste and Recycling; and Project Management.

Under general supervision of the Public Works Director, the Assistant Director supports the Director in oversight of the entire department by assisting with personnel issues, budgeting, long range planning, development of strategic initiatives, and representation on various boards and committees. The Assistant Director provides day-to-day direction, management, and oversight of the Building Maintenance, Grounds Maintenance, and Custodial Service divisions, and performs project management duties and oversees small tenant improvement and remodel projects. May be called to respond for emergency situations at any time, including weather and other building emergencies.

ESSENTIAL FUNCTIONS

- Oversees, manages, and supervises day-to-day operations and maintenance of building systems, custodial, and grounds, and project management and construction of facility improvements.
- Assists in the design and coordination of complex public works projects, providing technical assistance as required.
- Conducts short and long-range facilities management planning and identifies specific space and equipment needs to support future requirements.
- Establishes schedules for all projects and work requests; monitors work progress.
- Conducts periodic site visits to evaluate work quality to ensure compliance with applicable safety guidelines, building codes, and federal, state, and county regulations.
- Implements and maintains a comprehensive department safety program.
- In concert with the Director, establishes performance standards for facility preventative and regular maintenance activities including response times to work requests, time to completion, and work quality.
- Assists Director in establishing systems to identify, track, and maintain status records on County facilities in need of maintenance, remodeling, renovation, and repairs.
- Provides leadership and training to assigned staff; evaluates work of subordinates and conducts performance appraisals in a timely manner.
- Oversees preparation, accuracy, and timely submittal of staff work time via time keeping system.
- Monitors staff effectiveness and recognizes achievements as well as corrects deficiencies in performance.
- Administers a program of required and discretionary safety and skills enhancement and professional development training and other related activities.

- Develops and enforces organizational and departmental standard operating procedures including County policies, and safety rules and regulations.
- Prepares written and verbal technical reports to the Public Works Director, County Administrator, and external agencies, as required.
- Assists in the preparation, coordination, and control of the operating and capital improvement budgets for the Department.
- Monitors annual facilities modification/maintenance budgets to ensure that spending remains within established parameters.
- Coordinates contracting for outside skilled labor when needs cannot be met with in-house staff in order to maintain project budgets and meet project deadlines.
- Assists the Public Works Director in the contract preparation and negotiations with outside contractors and consultants on the design and construction of improvement projects.
- Acts on behalf of the Public Works Director by assignment or delegation in the director's absence.
- Performs other duties as assigned.

REQUIRED KNOWLEDGE, SKILLS AND ABILITIES

Knowledge of:

- Principles and practices of engineering and/or utility operations.
- Principles and practices of program development and administration.
- Principles of supervision, training and performance evaluation.
- Material and techniques of construction projects.
- Office procedures, methods, and equipment including computers and applicable software applications.
- Principles and practices of budget preparation and administration.
- Pertinent federal, state and local laws, codes and regulations.

Skills in:

- Leading teams and facilitating groups.
- Project and Program Management.
- Analyzing problems, identifying alternative solutions, and implementing recommendations.
- Time management, both self and others.

Ability to:

- Motivate and supervise team leads and front line staff.
- Establish and maintain effective working relationships with employees, department heads, County officials, and representatives from the private sector or other jurisdictions, and the public.
- Select, supervise, train and evaluate staff.
- Manage construction to deliver the project from planning, through bidding, construction and close out on time and on budget.
- Participate in the development and administration of department goals, objectives and procedures.
- Interpret and apply federal, state and local policies, laws and regulations.
- Prepare clear and concise administrative and project reports.
- Communicate clearly and concisely, both orally and in writing.

ACCEPTABLE EDUCATION, EXPERIENCE, AND TRAINING

- Education, training, and/or work experience equivalent to a Bachelor's degree from an accredited college or university with major course work in engineering, public administration, business administration or a related field.
- Five years of progressively responsible experience in public works , facility maintenance/ management, or similar field, and including two years of administrative and supervisory responsibility.

- Any equivalent combination of experience and education that will allow the applicant to satisfactorily perform the duties of the job may be considered when filling the position.

WORKING CONDITIONS AND PHYSICAL REQUIREMENTS

- Required to carry a cell phone and subject to recall at any time during an emergency and may be required to work long hours without normal days off.
- Must be able to travel in personal or assigned vehicle to emergency scenes, meetings, or public events in order to complete office assignments.
- Must be able to respond independently or as directed at odd hours and for extended periods of time during emergencies.
- Must be available to work some weekends and evenings for presentations, training, and meetings.
- Office environment exposure to computer screens; sitting for prolonged periods of time.
- Ability to work indoors/outdoors under adverse conditions for an extended period of time in the event of an emergency.
- Must have ability to occasionally lift, push/pull, and hold/carry 30 pounds.
- Must have the ability to frequently stand and sit, and occasionally walk over flat and uneven terrain.

SPECIAL REQUIREMENTS

- Must possess and maintain an appropriate driver's license valid in the Commonwealth of Virginia.

POST OFFER REQUIREMENTS

- Criminal background check and driving record check.

Department Head Recommended:	HR Manager Approval as to Form:	County Administrator Recommended:	Board of Supervisors Approved:
	November 2018	November 2018	Pending

FLUVANNA COUNTY BOARD OF SUPERVISORS
AGENDA ITEM STAFF REPORT

TAB M

MEETING DATE:	November 20, 2018				
AGENDA TITLE:	Position Description – Engineering Project Manager				
MOTION(s):	I move to approve the new Position Description 3685, Engineering Project Manager, as presented.				
STRATEGIC INITIATIVE?	Yes	No	If yes, list initiative(s):		
		x			
AGENDA CATEGORY:	Public Hearing	Action Matter	Presentation	Consent Agenda	Other
				x	
STAFF CONTACT(S):	Jessica Rice, HR Manager, and Steve Nichols, County Administrator				
PRESENTER(S):	Jessica Rice, HR Manager				
RECOMMENDATION:	Approval				
TIMING:	Current				
DISCUSSION:	This is a new position description to provide project management services for our ongoing ZXR and JRWA water and sewer projects. Salary costs are within the existing budgeted project funds.				
FISCAL IMPACT:	Costs attributable to already budgeted project costs.				
POLICY IMPACT:	Will reduce reliance on contract support for construction management and construction inspection services.				
LEGISLATIVE HISTORY:	N/A				
ENCLOSURES:	New Position Description				
REVIEWS COMPLETED:	Legal	Finance	Purchasing	HR	Other
				x	



Fluvanna County, Virginia
Department of Administration
Job Description

ENGINEERING PROJECT MANAGER

Job Class #:	3685
Pay Grade:	21
Category:	Full-Time (with benefits)
FLSA Status:	Exempt
Reports To:	County Administrator

SUMMARY

Provides planning, design, project management, and contract administration and inspection of utility projects, as well as various other construction and engineering projects. Works under the general supervision of the County Administrator.

ESSENTIAL FUNCTIONS

- Plans, directs and coordinates activities of assigned areas of responsibility.
- Responsible for all phases of assigned projects from inception through project close out, including planning, budgeting, design, procurement/project delivery, permitting, construction, contract administration, and final acceptance.
- Provides design and/or design assistance and prepares cost estimates on engineering projects including water and wastewater capital improvements.
- Coordinates activities with local jurisdictions, state and federal agencies, private businesses, contractors, consultants and others involved with projects.
- Assists the Purchasing Officer with Requests for Proposal for professional services and manages architectural/engineering consultants in the preparation of studies, reports, designs, plans, specifications, cost estimates, easements, and plats.
- Assists the Purchasing Officer with Invitations for Bid, Project Manuals, Technical Specifications, and construction contract documents, and manages the procurement of construction services for assigned projects.
- Provides technical evaluations, comments and assistance in the area of utility engineering and hydraulic analysis.
- Conducts or coordinates field surveys, mapping, database management, design, and inspection for a variety of engineering projects.
- Conducts field inspections as necessary.
- Prepares short and long-range plans for assigned area to include financial analysis and project review.
- Assists with formulating and administering policies, procedures, standards, plans, and programs.
- Reviews plans and specifications for various projects.
- Assists with formulating long-range programs for utility improvements.
- Assists customers and staff with questions relating to water and sewer projects, facilities, infrastructure, and services.
- Prepares Board of Supervisor reports (staff studies) for various engineering related projects, for presentation and action by the Board.
- Engages in engineering research, prepares a variety of technical reports and gives presentations of same

as required.

- Participates in various work teams.
- Performs other duties as assigned.

REQUIRED KNOWLEDGE, SKILLS AND ABILITIES

Knowledge of:

- Principles and practices of civil engineering as related to design and preparation of plans and specifications for a wide variety of utility and engineering projects.
- Equipment, materials, methods and procedures, safety standards, and specifications used in water and sewer related activities.
- Land and engineering survey systems methods and techniques.
- Water and/or sewer modeling, CAD, and GIS.
- Virginia Public Procurement Act.

Ability to:

- Develop, review and recommend processes and procedures for assigned area; identify and discuss impact on assigned area, the division, and the entire organization.
- Think logically and analyze data.
- Effectively present information to management, public groups, and/or other County employees.
- Establish and maintain effective working relationships with co-workers, other departments and agencies, and the general public.
- Work with minimal supervision and resolve conflict.
- Analyze and solve difficult technical and administrative problems.
- Define problems, collect data, establish facts and draw valid conclusions.
- Read and interpret documents such as safety rules, operating and maintenance instructions, maps and procedure manuals.
- Utilize prior experience and knowledge to carry out instructions furnished in writing, oral, or diagram form.
- Write reports, correspondences and procedure manuals in a clear concise manner.
- Work independently or in a team environment.
- Maintain a good work ethic concerning attendance, punctuality, positive attitude, meeting deadlines, and collaboration.

Skills in:

- Operating computers and software associated with job responsibilities, including typical computer software applications including; asset management, work order system(s), and financial systems, Microsoft Office (Word, Excel, Access, etc.), and Adobe Acrobat.
- Interpreting an extensive variety of technical instructions in mathematical or diagram form and dealing with several abstract and concrete variables.
- Adapting approved engineering methods and standards to the design and construction of a variety of utility projects.

ACCEPTABLE EDUCATION, EXPERIENCE, AND TRAINING

- Bachelor's degree from an accredited college or university with a major in civil engineering or related field
- Five (5) or more years of related experience in professional civil engineering work demonstrating progressive responsibility; an equivalent combination of education and experience may be considered

- Current licensure as a professional engineer in the Commonwealth of Virginia, or proven ability to obtain by reciprocity within 90 days of employment date
- Graduate study in the areas of water resources, hydraulics, sanitary engineering, or other related field preferred.

WORKING CONDITIONS AND PHYSICAL REQUIREMENTS

This is sedentary work requiring the exertion of up to 10 pounds of force occasionally and a negligible amount of force to frequently move objects; work requires kneeling, crouching, reaching, standing, walking, and grasping; vocal communication is required for expressing or exchanging ideas by means of the spoken word; hearing is required to perceive information at normal decibel levels of spoken word; visual acuity is required for preparing and analyzing written or computer data, operation of motor vehicles or equipment, determining the accuracy and thoroughness of work, and observing general surroundings and activities; the worker is subject to inside and outside environmental conditions. Reasonable accommodations may be made to enable individuals with disabilities to perform the essential tasks.

SPECIAL REQUIREMENTS

- Possession of an appropriate driver's license valid in the Commonwealth of Virginia.

POST OFFER REQUIREMENTS

- Criminal background check and driving record check.

Department Head Recommended:	HR Manager Approval as to Form:	County Administrator Recommended:	Board of Supervisors Approved:
	November 2018	November 2018	Pending

**FLUVANNA COUNTY BOARD OF SUPERVISORS
MEETING PACKAGE ATTACHMENTS**

No.	Item
1	FY18 BOS Contingency Balance Report – November 20, 2018
2	FY18 Capital Reserve Memo – November 20, 2018
3	Unassigned Fund Balance Report – November 20, 2018
4	Treasurer’s Bank Balances Report – October 31, 2018
5	Building Inspections Monthly Report – October 2018
6	
7	
8	
9	
10	

BUILDING INSPECTIONS MONTHLY REPORT

County of Fluvanna

Building Official:	Period:
Kevin Zoll	October, 2018

Category	Year	Jan	Feb	Mar	Apr	May	Jun	Jul	Aug	Sep	Oct	Nov	Dec	TOTAL
BUILDING PERMITS ISSUED														
NEW - Single Family Detached (incl. Trades permits)	2014	7	1	4	6	9	16	5	12	6	8	4	9	87
	2015	4	5	10	9	12	12	14	13	2	4	7	3	95
	2016	11	11	8	15	9	18	6	5	9	2	6	8	108
	2017	3	2	16	6	4	10	6	5	14	5	7	13	91
	2018	8	3	15	11	13	17	13	10	8	8			106
NEW - Single Family Attached	2014	0	0	6	0	0	0	0	0	0	0	2	0	8
	2015	2	0	0	0	0	0	0	2	0	0	0	0	4
	2016	0	0	0	0	0	5	0	0	0	0	0	0	5
	2017	0	0	0	0	0	0	0	0	0	0	0	0	0
	2018	0	0	0	0	0	0	0	0	0	0	0	0	0
NEW - Mobil Homes	2014	0	1	1	0	0	1	1	0	1	0	0	0	5
	2015	0	0	0	0	1	1	0	2	0	0	0	0	4
	2016	0	1	0	0	0	0	0	1	0	0	0	0	2
	2017	0	0	0	0	2	1	0	1	0	0	0	0	4
	2018	0	0	1	1	0	0	0	0	0	0	0	0	2
Additions and Alterations	2014	22	12	17	29	31	28	18	28	31	36	25	25	302
	2015	21	30	38	28	21	30	22	25	23	27	35	18	318
	2016	13	10	31	27	29	29	15	32	31	28	27	27	299
	2017	29	20	29	43	20	29	32	18	23	27	43	28	341
	2018	19	6	10	19	8	13	26	25	32	42			200
Accessory Buildings	2014	2	0	2	0	4	1	3	5	1	2	2	1	23
	2015	4	4	3	4	1	0	0	2	6	0	0	3	27
	2016	3	4	4	6	2	2	1	2	1	3	3	6	37
	2017	0	4	2	3	2	2	2	4	2	0	2	2	25
	2018	2	3	3	6	2	1	4	2	1	2			26
Swimming Pools	2014	0	0	0	1	0	0	0	0	0	0	0	1	2
	2015	0	0	0	0	0	0	0	1	1	0	0	0	2
	2016	0	0	0	0	0	1	1	0	0	0	0	0	2
	2017	0	0	0	0	0	1	1	0	0	1	1	0	4
	2018	0	1	1	1	0	1	2	0	1	2			9
Commercial/Industrial Build/Cell Towers	2014	0	0	0	0	0	2	1	0	0	0	0	1	4
	2015	1	0	0	0	0	0	2	0	0	1	1	1	6
	2016	0	0	2	2	0	0	1	0	1	1	1	1	9
	2017	1	2	0	0	0	0	2	2	1	1	0	0	9
	2018	0	0	0	0	0	2	0	0	0	0			2
TOTAL BUILDING PERMITS	2014	31	14	30	36	44	48	28	45	39	46	33	37	431
	2015	32	39	51	41	35	43	38	45	32	32	43	25	456
	2016	27	26	45	50	40	55	24	40	42	34	37	42	462
	2017	33	28	47	52	28	43	43	30	40	34	53	43	474
	2018	29	13	30	38	23	34	45	37	42	54	0	0	345
BUILDING VALUES FOR PERMITS ISSUED														
TOTAL BUILDING VALUES	2014	\$1,902,399	\$458,326	\$1,783,992	\$2,540,111	\$2,570,600	\$3,119,933	\$1,724,192	\$2,586,705	\$1,353,471	\$1,922,260	\$1,461,680	\$2,563,409	\$ 23,987,078
	2015	\$1,384,631	\$1,560,716	\$2,916,520	\$3,567,237	\$2,999,918	\$4,280,357	\$5,272,378	\$3,107,731	\$2,625,563	\$2,203,913	\$1,931,893	\$6,252,403	\$ 38,103,260
	2016	\$1,817,981	\$2,555,455	\$5,542,458	\$3,711,821	\$2,447,891	\$5,181,921	\$3,611,179	\$1,817,783	\$3,089,971	\$1,889,279	\$2,028,590	\$2,937,783	\$ 36,632,112
	2017	\$857,767	\$827,724	\$4,859,777	\$2,066,132	\$1,512,789	\$3,676,118	\$1,904,915	\$2,359,988	\$2,846,545	\$1,957,646	\$1,897,110	\$3,479,285	\$ 28,245,796
	2018	\$2,541,433	\$1,075,551	\$3,544,096	\$2,513,241	\$3,834,995	\$5,693,348	\$3,156,593	\$4,729,005	\$3,637,992	\$1,791,222			\$ 32,517,476

Category	Year	Jan	Feb	Mar	Apr	May	Jun	Jul	Aug	Sep	Oct	Nov	Dec	TOTAL
LAND DISTURBING PERMITS ISSUED														
LAND DISTURBING PERMITS	2014	8	1	10	4	8	16	3	10	5	9	6	10	90
	2015	6	5	9	10	10	12	15	16	3	5	10	5	106
	2016	12	11	8	14	10	17	7	6	11	3	9	9	117
	2017	3	2	17	7	7	9	6	6	15	8	7	14	101
	2018	10	4	16	13	11	17	13	7	9	6			106
INSPECTIONS COMPLETED														
TOTAL INSPECTIONS	2014	135	149	103	180	113	168	173	148	155	167	112	162	1,765
	2015	105	137	146	214	113	232	193	181	208	206	149	149	2,033
	2016	116	91	153	157	155	214	249	230	197	181	184	172	2,099
	2017	159	144	171	141	177	152	202	182	153	183	181	169	2,014
	2018	163	148	173	186	215	176	164	220	144	221			1,810
FEES COLLECTED														
Building Permits	2014	\$9,160	\$2,655	\$10,041	\$11,601	\$11,808	\$18,950	\$6,913	\$12,848	\$8,080	\$11,602	\$9,740	\$11,568	\$ 124,966
	2015	\$6,731	\$8,351	\$13,711	\$16,037	\$13,508	\$16,628	\$14,931	\$18,895	\$10,411	\$8,558	\$10,381	\$9,575	\$ 147,717
	2016	\$11,850	\$11,954	\$11,576	\$14,889	\$8,447	\$18,588	\$12,947	\$7,537	\$11,285	\$12,548	\$8,361	\$11,213	\$ 141,195
	2017	\$4,060	\$3,660	\$22,692	\$9,249	\$6,703	\$11,948	\$9,494	\$7,790	\$13,169	\$6,895	\$9,022	\$12,886	\$ 117,568
	2018	\$8,988	\$4,311	\$9,939	\$14,765	\$13,796	\$23,633	\$14,993	\$8,748	\$10,826	\$12,613			\$ 122,612
Land Disturbing Permits	2014	\$2,125	\$1,225	\$2,400	\$2,300	\$1,310	\$8,500	\$2,739	\$2,850	\$625	\$2,839	\$2,450	\$2,850	\$ 32,213
	2015	\$1,775	\$875	\$1,425	\$3,425	\$1,750	\$1,850	\$2,325	\$3,338	\$1,085	\$2,819	\$10,450	\$2,298	\$ 33,415
	2016	\$3,200	\$2,575	\$1,700	\$1,950	\$2,250	\$2,200	\$4,020	\$875	\$28,074	\$2,000	\$1,450	\$1,200	\$ 51,494
	2017	\$475	\$800	\$7,000	\$1,523	\$2,366	\$2,425	\$1,733	\$7,784	\$2,100	\$2,050	\$1,000	\$1,625	\$ 30,881
	2018	\$1,450	\$5,975	\$1,890	\$1,625	\$1,625	\$2,850	\$1,625	\$1,175	\$1,125	\$875			\$ 20,215
Zoning Permits/ Proffers	2014	\$1,000	\$250	\$1,800	\$1,100	\$14,200	\$2,400	\$1,050	\$19,900	\$1,400	\$1,350	\$950	\$1,700	\$ 47,100
	2015	\$1,200	\$1,000	\$1,650	\$2,600	\$1,500	\$1,850	\$1,850	\$2,400	\$1,650	\$1,050	\$900	\$850	\$ 18,500
	2016	\$1,150	\$1,250	\$1,800	\$2,450	\$1,650	\$2,700	\$1,150	\$1,150	\$1,900	\$1,050	\$900	\$850	\$ 18,000
	2017	\$400	\$1,000	\$2,400	\$950	\$1,500	\$1,800	\$1,245	\$1,250	\$1,600	\$1,050	\$1,250	\$1,550	\$ 15,995
	2018	\$1,400	\$800	\$1,750	\$1,600	\$1,400	\$2,200	\$2,050	\$1,400	\$1,050	\$1,400			\$ 15,050
TOTAL FEES	2014	\$12,285	\$4,130	\$14,241	\$15,001	\$27,318	\$29,850	\$10,702	\$35,598	\$10,105	\$15,791	\$13,140	\$16,118	\$ 204,279
	2015	\$9,706	\$10,226	\$16,786	\$22,062	\$16,758	\$20,328	\$19,106	\$24,633	\$13,146	\$12,427	\$21,731	\$12,723	\$ 199,632
	2016	\$16,200	\$15,779	\$15,076	\$19,289	\$12,347	\$23,488	\$18,117	\$9,562	\$41,259	\$15,598	\$10,711	\$13,263	\$ 210,689
	2017	\$4,935	\$5,460	\$32,092	\$11,722	\$10,569	\$16,173	\$12,472	\$16,824	\$16,869	\$9,995	\$11,272	\$16,061	\$ 164,444
	2018	\$11,838	\$11,086	\$13,579	\$17,990	\$16,821	\$28,683	\$18,668	\$11,323	\$13,001	\$14,888	\$0	\$0	\$ 157,877

MEMORANDUM

Date: November 21, 2018
From: Eric Pollitt – Management Analyst
To: Board of Supervisors
Subject: FY19 BOS Contingency Balance

The FY19 BOS Contingency line balance is as follows:

Beginning Budget:	\$150,000.00
Less: FY19 Non-Profit Budget Allocations Change – 05.16.18	-\$14,180.00
Less: FY19 C.A.R.E. Task Force Container for Clean Up Day – 09.19.18	-\$500.00
Available:	\$135,320.00

MEMORANDUM

Date: November 21, 2018
From: Eric Pollitt – Management Analyst
To: Board of Supervisors
Subject: FY19 Capital Reserve Balances

The FY19 Capital Reserve account balances are as follows:

County Capital Reserve:

FY19 Budget Allocation:	\$0
FY18 Carryover	\$67,256
FY18 Closed Out Projects	\$163,865
Total FY19 Budget:	\$231,121
Less: I.T. Air Conditioning Unit – 09.19.18	-\$7,000
Less: FSPCA Building Renovations – 10.17.18	-\$45,000
Less: Palmyra Rescue Squad Building Renovations – 10.17.18	-\$15,000
FY19 Available:	\$164,121

Schools Capital Reserve:

FY19 Budget Allocation:	\$150,000
FY18 Carryover	\$116,308
FY18 Closed Out Projects	\$13,046
Total FY19 Budget:	\$266,308
Plus: BOS Unassigned Fund Balance: Middle School Debt Proceeds – 09.19.18	\$72,001
Less: Abrams Abatement: Classroom & Crawl Space – 09.19.18	-\$72,001
Less: Carysbrook & Central Elementary Blacktop Repair – 09.19.18	-\$10,650

Less: Central Elementary School Partition – 09.19.18	-\$12,000
Less: Bus 21 Engine/ Motor Replacement – 11.07.18	-\$22,500
FY19 Available:	\$234,204

MEMORANDUM

Date: November 21, 2018
From: Eric Pollitt – Management Analyst
To: Board of Supervisors
Subject: Unassigned Fund Balance

*FY18 Year End (Unaudited) Unassigned Fund Balance – Excess Above Policy Target:	\$4,078,805
Less: FY19 Abrams Abatement Classroom and Crawl Space – 09.19.18	-\$72,001
Less: FY19 Fire Hydrant Installation (JRWA) – 10.17.18	-\$142,500
Current (Unaudited) Unassigned Fund Balance – Excess Above Policy Target:	\$4,078,805

*Audited FY18 Year End Unassigned Fund Balance will be available upon completion of the FY18 CAFR

Fluvanna County Monthly Bank and Investment Account Balances and Earnings Report

Month	Wells Fargo Commercial Checking - Main Bank	BB&T - Cost Recovery Fund	VA Investment Pool (VIP) Stable NAV Liquidity Pool	VIP Stable NAV Earnings	VA Investment Pool (VIP) 1-3 Year High Quality Bond Fund	VIP 1-3 Year Earnings	Ending Balance TOTAL
Jul-16	\$ 10,053,334	\$ 332,174			\$ 7,152,669	\$ (2,455)	\$ 17,538,177
Aug-16	\$ 6,733,878	\$ 377,034			\$ 7,142,574	\$ (10,095)	\$ 14,253,486
Sep-16	\$ 3,127,373	\$ 417,387			\$ 7,150,195	\$ 7,622	\$ 10,694,955
Oct-16	\$ 2,408,014	\$ 465,326			\$ 7,144,306	\$ (5,889)	\$ 10,017,646
Nov-16	\$ 6,337,061	\$ 511,779			\$ 7,111,653	\$ (32,653)	\$ 13,960,493
Dec-16	\$ 10,222,656	\$ 568,084			\$ 7,112,980	\$ 1,327	\$ 17,903,720
Jan-17	\$ 6,794,517	\$ 601,955			\$ 7,124,549	\$ 11,562	\$ 14,521,021
Feb-17	\$ 6,276,766	\$ 648,260			\$ 7,131,495	\$ 6,947	\$ 14,056,520
Mar-17	\$ 4,372,044	\$ 699,524			\$ 7,133,155	\$ 1,660	\$ 12,204,723
Apr-17	\$ 1,856,533	\$ 734,130			\$ 7,147,486	\$ 14,331	\$ 9,738,149
May-17	\$ 5,134,100	\$ 772,183			\$ 7,155,655	\$ 8,168	\$ 13,061,937
Jun-17	\$ 14,272,459	\$ 815,451			\$ 7,155,722	\$ 67	\$ 22,243,632
Jul-17	\$ 9,473,371	\$ 854,310	\$ -	\$ -	\$ 7,178,718	\$ 12,852	\$ 17,506,399
Aug-17	\$ 5,699,776	\$ 890,237	\$ -	\$ -	\$ 7,185,438	\$ 11,237	\$ 13,775,452
Sep-17	\$ 1,497,668	\$ 431,051	\$ -	\$ -	\$ 7,192,355	\$ (4,928)	\$ 9,121,074
Oct-17	\$ 3,270,241	\$ 35,223	\$ 135	\$ 135	\$ 4,170,653	\$ (4,230)	\$ 7,476,252
Nov-17	\$ 7,739,856	\$ 79,183	\$ 135	\$ 0	\$ 4,162,255	\$ (8,398)	\$ 11,981,429
Dec-17	\$ 13,640,973	\$ 144,416	\$ 135	\$ 0	\$ 4,160,490	\$ (1,765)	\$ 17,946,014
Jan-18	\$ 9,813,762	\$ 195,944	\$ 135	\$ 0	\$ 4,149,498	\$ (10,993)	\$ 14,159,339
Feb-18	\$ 8,302,311	\$ 183,287	\$ 50,138	\$ 2	\$ 4,146,305	\$ (3,192)	\$ 12,682,040
Mar-18	\$ 4,474,342	\$ 89,291	\$ 2,224,967	\$ 1,829	\$ 4,153,316	\$ 7,011	\$ 10,941,916
Apr-18	\$ 2,043,660	\$ 67,042	\$ 2,303,479	\$ 3,512	\$ 4,148,585	\$ (4,731)	\$ 8,562,767
May-18	\$ 11,822,481	\$ 18,984	\$ 2,422,389	\$ 3,910	\$ 4,162,798	\$ 14,213	\$ 18,426,652
Jun-18	\$ 9,675,143	\$ 73,593	\$ 9,435,967	\$ 13,578	\$ 4,161,567	\$ (1,231)	\$ 23,346,270
Jul-18	\$ 4,394,222	\$ 114,515	\$ 13,619,588	\$ 20,600			\$ 18,128,324
Aug-18	\$ 1,677,219	\$ 37,320	\$ 11,767,732	\$ 23,145			\$ 13,482,271
Sep-18	\$ 2,615,110	\$ 37,723	\$ 6,811,719	\$ 13,986			\$ 9,464,552
Oct-18	\$ 4,668,338	\$ 207,298	\$ 3,821,042	\$ 9,323			\$ 8,696,679
Nov-18							\$ -
Dec-18							\$ -
Jan-19							\$ -
Feb-19							\$ -
Mar-19							\$ -
Apr-19							\$ -
May-19							\$ -
Jun-19							\$ -