



COUNTY OF FLUVANNA, VIRGINIA

Request for Qualifications (RFQ) #2018-06

Burn Building Design-Build Project

Issue Date: May 03, 2018

Due Date: May 15, 2018 at 2 p.m. EST

Procurement Contact:

County of Fluvanna
Cyndi Toler, Purchasing Officer
132 Main Street
P.O. Box 540
Palmyra, VA 22963
Ph: (434) 591-1930 ext. 1124
Email: ctoler@fluvannaCounty.org

All sealed responses shall be turned in no later than May 15, 2018, at 2:00 p.m. EST.

- All responses that are delivered via mail or are hand delivered must be addressed to the "Procurement Contact" listed above.
- Any responses sent in via facsimile, telephone, or email shall not be considered.
- Any responses that are turned in late will be rejected and returned unopened.

Documents may be picked up at the Fluvanna County Department of Finance located at 132 Main Street, 2nd floor, Palmyra, VA 22963 or by clicking on the following link: <https://www.fluvannacounty.org/rfps>.

This RFQ is Step I in the County's two-step competitive negotiation process for a design-build project and will determine which Offerors are qualified to receive the Request for Proposal, being the second stage in the competitive negotiation process. This RFQ is being issued under **the County's Design Build ("D/B") Procedures** (the "D/B Procedures") which are attached hereto as Exhibit 7 and are incorporated herein as a material part hereof.

TABLE OF CONTENTS

1. PURPOSE..... 2

2. BACKGROUND 3

3. SCOPE OF SERVICES..... 3

4. PROPOSAL PREPARATION AND SUBMISSION INSTRUCTIONS 4

5. EVALUATION AND AWARD CRITERIA 6

6. GENERAL TERMS, CONDITIONS, AND INSTRUCTIONS TO BIDDERS AND CONTRACTORS 8

7. VENDOR DATA SHEET.....31

8. PROOF OF AUTHORITY TO TRANSACT BUSINESS IN VIRGINIA.....32

9. CERTIFICATION OF NO COLLUSION.....33

10. OFFEROR STATEMENT.....34

11. RFQ QUESTIONAIRE.....35

12. EXHIBIT 1.....38

13. EXHIBIT 2.....39

14. EXHIBIT 3.....40

15. EXHIBIT 7.....57

1) **PURPOSE**

- a) The County of Fluvanna (the "County") has received a grant (the "Grant") award from the Virginia Department of Fire Programs ("VDFP") for the construction of a new Burn Building as a prop to assist in training the fire service for the Fluvanna area. Pursuant to this Request for Qualifications (the "RFQ"), the County is seeking proposals from qualified firms to assist in the development of plans and specifications and for construction of a Prototype II, Class B Burn Building. The County has elected and been awarded funding to construct a Prototype 2, Class B Steel Frame Burn Building (the "Burn Building") on that property of the County known as Tax map Parcels 51 A 129 and 51 A 129A and also known by present street numbering as 5725 James Madison Highway, Fork Union, VA 23055 near the Fork Union Fire Department (the "Site") with such Site being more particularly depicted in the attached **Exhibit 1**. A Burn Building is a permanent structure whose sole use is for the purpose of training firefighters in a "live fire" experience scenario on a repetitive basis in accordance with the National Fire Protection Association 1001 and 1402 (NFPA 1402, 3.3.1).
- b) The proposed prototype plans for the Burn Building entitled "Commonwealth of Virginia Burn Building Prop Prototype 2 Metal Building – Class B Fuel" also referred to as VDVP "Prototype 2, Class B" (the "Prototype Plans") are attached hereto as **Exhibit 2**.
- c) This RFQ is required by the County's D/B Procedures which are a material part hereof (see Exhibit 7). The County is seeking to contract with a qualified offeror to both design and build the Burn Building as a design-build project and to complete all work required for the Project at the Site and all work and documentation required for the Grant relating thereto.
- d) Based upon the recommendation of a licensed engineer in its employ, the County has determined that:
 - i) The building design is based on a prototype developed by the Commonwealth of Virginia Department of Fire Programs, and is therefore reasonably simple and straightforward;
 - ii) The design includes integral equipment which is available as pre-engineered components (e.g. premanufactured burn-room components such as a "kitchen" or a "bedroom);
 - iii) Site development involves no unusual or complicated processes which may require specialized design processes; and
 - iv) There are firms which specialize in the design and construction of "Burn Buildings" as a complete or "turn-key" process, which can be expected to allow overall cost and time savings for the project.
- e) Therefore, by motion of the Board of Supervisors, the County is issuing this RFQ as it has determined that::
 - i) A design-build contract is more advantageous than a competitive sealed bid construction contract for the Burn Building and this Project;
 - ii) There is a benefit to the County by using a design-build contract for the Burn Building including without limitation those benefits set forth in (d) supra; and
 - iii) Competitive sealed bidding is not practical or fiscally advantageous for this Project.
- f) This RFQ is the first step in a 2-step competitive negotiation. In accordance with the D/B Procedures, based on a committee evaluation of qualification statements received in response to this RFQ, a minimum of 2 / maximum of 5 firms will be selected to participate in the next

step, and will receive a written Request for Proposals (RFP). At that time during the second step in competitive negotiations, firms will be requested to provide cost information, in a separately sealed and specifically identified Cost Proposal. **Offerors shall not include Cost Proposals in response to this RFQ.**

- g) **This RFQ is a prequalification process required for a design-build contract of the County. If a firm does not respond to this RFQ, the firm cannot be prequalified, cannot be considered at the RFP second step and cannot be awarded a contract for the Burn Building and related Project work.**
- h) The County will notify each offeror in writing if they are prequalified, or not.
- i) Only Prequalified offerors will be provided the RFP and will be required to respond by the due date set forth therein.
- j) The RFP, to be issued to prequalified firms who respond to this RFQ only, will identify, to the extent possible, the requirements for this Project along with submittal requirements for a technical and Cost Proposal with a fixed or not-to-exceed cost (to be submitted as part of the second step only, and not to this RFQ). Based on a committee evaluation of proposals received in response to the RFP, the firm deemed best suited will be identified. Cost will be considered at the second step in reviewing responses to the RFP and determining award of the contract to an offeror, if any.

2) BACKGROUND

- a) The County of Fluvanna is a central Virginia community of 26,000 residents that is located in the Charlottesville Metropolitan Statistical Area, approximately 20 miles southeast of the City of Charlottesville, Virginia. The County is bounded by Louisa County to the north, Cumberland and Buckingham Counties and the James River to the south, Goochland County to the east, and Albemarle County to the west.
- b) VDFP requires that the Burn Building be engineered and constructed consistent with the VDPF's "Live Fire Training Structure Grant Program" Policy attached hereto as **Exhibit 3** ("VDFP Policy").
- c) VDFP requires that the Burn Building be engineered, constructed, used and operated in compliance with the current version of the National Fire Protection Association 1403 Standard on Live Fire Training Evolutions ("NFPA 1403 Compliance").

3) SCOPE OF SERVICES

- a) Contractor shall provide, furnish deliver, supply and install, all necessary or appropriate labor, services, parts, tools, materials, equipment, items and resources as may be required to complete the work on the Project (the "Scope of Work"), in accordance with the specifications and terms and conditions stated herein, which Scope of Work, shall include at minimum, but is not limited to, all of the following:
 - i) The development of a site plan for the Burn Building at the Site,
 - ii) Drafting of structurally engineered plans and specifications for the Burn Building using the Prototype Plans (Exhibit 2),
 - iii) Construction of Prototype 2, Class B burn building,
 - iv) Complying with all requirements of the Grant, and

- v) Complying with all requirements of the County's D/B Procedures.
- b) This project shall be designed, constructed and administered in accordance with the Grant, NFPA 1403 and the VDFP Policy, VDFP's "Agency Practices, Policies" and the "Burn Building Project Manual." All documents are available on VDFP's website at www.vafire.com under the Grants and Local Aid: Burn Building link.
- c) The County and its designees are to administer the project in accordance with all applicable federal, state and local laws and regulations. All project activities will be under the direction of the County's Project Manager, Ben Powell.
- d) Funds
 - i) The method of payment for this contract will be by fixed price or not to exceed payment including all reimbursable administrative or other expenses of any kind.
 - ii) Offerors acknowledge and understand that per Section G(3) of the VDFP Policy, grants funds cannot be used for ancillary costs as more specifically described in the VDFP Policy.

4) PROPOSAL PREPARATION AND SUBMISSION INSTRUCTIONS

a) GENERAL INSTRUCTIONS

- i) **RFQ Response:** In order to be considered for selection, interested parties must submit a complete response to this RFQ. Failure to comply with all criteria listed herein may be cause to reject an Offeror's proposal

- ii) **RFQ Questions:** Address questions concerning this RFQ to:

Cyndi Toler, Purchasing Officer
 P.O. Box 540
 132 Main Street
 Palmyra, VA 22963
 Ph: (434) 591-1930
ctoler@fluvannaCounty.org

Offerors shall submit any questions in writing. Written responses, including the questions, will be posted with the RFQ. Questions will not be accepted after May 7, 2018 at 2pm

- iii) **Ownership of Qualifications:** Ownership of all data, materials, and documentation originated and prepared for the County pursuant to the RFQ shall belong exclusively to the County and be subject to public inspection in accordance with the Freedom of Information Act. Any proprietary or trade secrets material submitted must be identified as such, and must indicate the specific words, figures, or paragraphs specifically, and with a reason why such material is proprietary or a trade secret. The classification of an entire proposal document, individual pricing or total proposal prices is not acceptable and will result in rejection and return of the proposal.
- iv) **Incurred Expenses:** The County will not be liable for any cost incurred by Offerors in preparing and submitting proposals. Offerors may not collect proposal preparation charges from the County of Fluvanna as a result of cancellation of this RFQ.
- v) **Due Date:** Sealed copies of the proposal must be received by the Purchasing Officer no later than 2:00 p.m. EST on May 15, 2018. Proposals in response to this RFQ must be addressed to:

Cyndi Toler, Purchasing Officer
P.O. Box 540
132 Main Street
Palmyra, VA 22963
RFQ-2018-01

- vi) **Any Proposals that are turned in late will be rejected and returned unopened. Any Proposals sent in via facsimile, telephone, or email shall not be considered.**

b) **PROPOSAL PREPARATION**

- i) The County will follow the evaluation process and selection criteria described in this Request for Qualifications. In order to provide each Offeror an equal opportunity for consideration, adherence to a standardized proposal format is required. The format of each proposal must contain the following elements organized into separate chapters and sections, as the Offeror may deem appropriate. The following paragraphs provide guidelines to each Offeror for information to include in the proposal:
- ii) **Cover Letter** - Provide a cover letter that confirms the Offeror's understanding of this Request for Proposal, an overview of the history and qualifications of the firm.
- iii) **Forms** - All forms required to be submitted under this RFQ must be included in the Proposal as an Appendix.
- (1) Certificate of No Collusion
 - (2) Offeror Statement
 - (3) Proof of Authority to Transact Business in Virginia
 - (4) Vendor Data Sheet
 - (5) RFQ QUESTIONNAIRE
- iv) **Overview** - The purpose of this section is to provide the County with an overview of the history, qualifications and abilities of the Offeror's firm and for the Offeror to demonstrate the specific qualifications of the staff the Offeror will assign to this project if selected. At a minimum, the proposal should:
- (1) Designate a Project Manager and indicate office location.
 - (2) Designate the Registered Design Professional.
 - (3) Include the organization chart, functional discipline, and responsibilities of project team members.
 - (4) Provide any additional information you feel is relevant to the selection.
- v) **Resumes** - Provide a concise resume or description of each team member's education, relevant professional experience, length of time employed by the Offeror and/or sub-consultant, and professional license.
- vi) **Representative Projects**: This section of the Offeror's Proposal should list and describe representative clients currently served focusing on VDFP grant projects. Describe the local office experience including the project name and location, brief description of the project, description of the scope of services provided, and principal contact person. The Offeror must include a description of every VDFP burn building project it has worked on in Virginia.

- vii) **References:** Provide the current name, address, and telephone number of at least five (5) references the Offeror has served either currently or in the past three (3) years; preferably those where one or more of the project team members provided the same or similar services as requested herein. Indicate the Scope of Services provided to each reference.
- viii) **Addenda:** Return the RFQ cover sheet and all addenda acknowledgments, if any, signed and filled out as required. By submitting a proposal Offerors certify that all information provided in response to this RFQ is true and accurate.
- c) The County is not responsible for failure to locate, consider and evaluate qualification factors presented outside this format.

5) EVALUATION AND AWARD CRITERIA

- a) The County will evaluate submissions in response to this RFQ and intends to select a minimum of 2 / maximum of 5 firms to participate in the next step, to receive a written Request for Proposal (RFP). The firms selected will be required to demonstrate its ability to provide the services required effectively with complete impartially and without any conflict of interest. **The selection of Qualified Offerors at the RFQ step one stage shall be based on the following criteria:**
 - i) Qualifications and experience of key contract team members who are actively involved throughout the entire contract. **(20 points)**
 - ii) Relevant experience with similar projects. **(40 points)**
 - iii) Specific plan and/or methodology to be used to perform the services. **(20 points)**
 - iv) References from other similar projects. **(20 Points)**
- b) **DOES NOT APPLY AT STAGE ONE, FOR INFORMATIONAL PURPOSES ONLY: The selection of the offeror in response to the RFP step two stage will be based on:**
 - i) Qualifications and experience of key contract team members who are actively involved throughout the entire contract. **(15 points)**
 - ii) Relevant experience with similar projects. **(35 points)**
 - iii) Specific plan and/or methodology to be used to perform the services. **(15 points)**
 - iv) References from other similar projects. **(15 Points)**
 - v) **Costs (20 Points).** (Note: Cost is only considered if applicable, see D/B Procedures Section 7-5.1.2(e) and (f))
- c) The Selection Committee may make such reasonable investigations as it deems proper and necessary to determine the ability of the Offeror to perform the work.
- d) The County reserves the right to make such additional investigations as it may deem necessary to establish competency and financial stability of any Offeror. If, after the investigation, the evidence of competency and financial stability is not satisfactory, in the sole opinion of the County.
- e) The County of Fluvanna may cancel this Request for Qualifications or reject proposals at any time prior to an award, and is not required to furnish a statement of the reason why a particular proposal was not deemed to be the most advantageous (Section 11-65D, Code of Virginia). The award document will be a contract incorporating by reference all requirements, terms and conditions of the solicitation and the contractor's proposal as negotiated.

- f) The County's General Terms, Conditions, and Instructions to Bidders and Contractors are attached hereto and incorporated herein by reference as Section 6. These provisions bind all Offerors. Further, the conditions and requirements of this RFQ, including, but not limited to, County's General Terms, Conditions, and Instructions to Bidders and Contractors, are a material part of any contract awarded between the County and the successful Offeror(s).
- g) Awards shall be made to as many Offerors as deemed necessary to fulfill the anticipated requirements of the County.

6) **GENERAL TERMS, CONDITIONS, AND INSTRUCTIONS TO BIDDERS AND CONTRACTORS**

ATTACHED

GENERAL TERMS, CONDITIONS AND INSTRUCTIONS TO BIDDERS AND CONTRACTORS

These General Terms, Conditions and Instructions to Bidders and Contractor (hereinafter referred to as the “General Conditions”) shall apply to all purchases and be incorporated into and be a part of each Solicitation (as defined below) and every Contract (as defined below) awarded by Fluvanna County, a political subdivision of the Commonwealth of Virginia (hereinafter referred to as the “County”) unless otherwise specified by the County in writing. Bidders, Offerors and Contractors or their authorized representatives are expected to inform themselves fully as to these General Conditions before submitting Bids or Proposals to and/or entering into any Contract with the County: failure to do so will be at the Bidder’s/Contractor’s own risk and except as provided by law, relief cannot be secured on the plea of error.

Subject to all Federal, State and local laws, policies, resolutions, regulations, rules, limitations and legislation, including the County’s Procurement Policies and Procedures, Bids or Proposals on all Solicitations issued by County will bind Bidders or Offerors, as applicable, and Contracts will bind Contractors, to all applicable terms, conditions, instructions, rules and requirements herein set forth unless otherwise SPECIFICALLY set forth by the County in writing in the Solicitation or Contract. All provisions of these General Conditions are material to any contract between the County and a Contractor.

INTRODUCTION

- 1. VIRGINIA PUBLIC PROCUREMENT ACT AND ETHICS IN PUBLIC CONTRACTING:** The Virginia Public Procurement Act of Virginia Code §§ 2.2-4300 *et seq.* (hereinafter the “VPPA”) is incorporated herein by reference. Nothing in these General Conditions is intended to conflict with the VPPA and in case of any conflict, the VPPA controls. Specifically, the provisions of Article 6 of the VPPA (Virginia Code §§ 2.2-4367 through 2.2-4377) relating to ethics in contracting, shall be applicable to all Solicitations and Contracts solicited or entered into by the County. By submitting their Bids or signing any Contract, all Bidders and Contractors certify that they have not violated any of the provisions of Article 6 of the VPPA, including, but not limited to, that their Bids are made without collusion or fraud and that they have not offered or received any kickbacks or inducements.
- 2. DEFINITIONS:** The definitions of Virginia Code §§ 2.2-4301, 2.2-4302.1 and 2.2-4302.2 are specifically incorporated herein by reference and as used in these General Conditions, whether capitalized or not, any of such defined terms have the same meaning as such terms have under the VPPA: such defined terms include: “Affiliate”, “Best Value”, “Business”, “Competitive Negotiation”, “Competitive Sealed Bidding”, “Construction”, “Construction Management Contract”, “Design-Build Contract”, “Employment Services Organization”, “Goods”, “Informality”, “Job Order Contracting”, “Multiphase Professional Services Contract”, “Nonprofessional Services”, “Potential Bidder or Offeror”, “Professional Services”, “Public Body”, “Public Contract”, “Responsible Bidder or Offeror”, “Responsive Bidder”, “Reverse Auctioning” and “Services”. Additionally, as used in these General Conditions, the following terms, whether capitalized or not, have the following meanings:
 - a. **Bid/Proposal:** The offer of a Bidder or Offeror to provide specific Goods or Services at specified prices and/or other conditions specified in the Solicitation. The term “Bid” is used throughout these General Conditions and where appropriate includes the term “Proposal” or any modifications or amendments to any Bid or Proposal.

- b. Bidder/Offeror/Vendor: Any individual(s), company, firm, corporation, partnership or other organization bidding or offering on any Solicitation issued by the County and/or offering to enter into Contracts with the County. The term “Bidder” is used throughout these General Conditions and where appropriate includes the term “Offeror” and/or “Vendor”.
- c. Contract: Any contract to which the County will be a party.
- d. Contractor: Any individual(s), company, firm, corporation, partnership, or other organization to whom an award is made by the County or whom enters into any contract to which the County is a party.
- e. County: The County of Fluvanna, a political subdivision of the Commonwealth of Virginia, including where applicable all agencies and departments of the County.
- f. County Administrator: The Fluvanna County Administrator.
- g. County Attorney: The Fluvanna County Attorney.
- h. Purchasing Agent: The County Administrator is the County’s Purchasing Agent and is responsible for the purchasing activity of Fluvanna County; and has signatory authority to bind the County to all contracts and purchases made lawfully under the Fluvanna County Small Purchasing Procedures. The Purchasing Agent has signatory authority to bind the County to all other contracts and purchases only after the contracts or purchases have been approved by a vote of the Fluvanna County Board of Supervisors.
- i. General Terms, Conditions and Instructions to Bidders and Contractors (also referred to herein as the “General Conditions”): These General Terms, Conditions and Instructions to Bidders and Contractors shall be attached to and made a part of all Solicitations by the County and all Contracts to which the County is party.
- j. His: Any references to “his” shall include his, her, their, or its as appropriate.
- k. Invitation to Bid (also referred to herein as an “IFB”): A request which is made to prospective Bidders for their quotation on Goods or Services desired by the County. The issuance of an IFB will contain or incorporate by reference the General Conditions and the other specifications and contractual terms and conditions applicable to the procurement.
- l. Purchasing Officer: The Purchasing Officer employed by the County and to whom Bidders/Contractors can submit questions relating to any Bid or Contract.
- m. Request for Proposal (also referred to herein as a “RFQ”): A request for an offer from prospective Offerors which shall indicate the general terms which are sought to be procured from Offerors. The RFQ will specify the evaluation factors to be used and will contain or incorporate by reference the General Conditions and other applicable contractual terms and conditions, including any unique capabilities or qualifications that will be required of the Contractor.
- n. Small Purchasing Procedures: The County’s Small Purchasing Procedures, being Chapter 4 of the County’s Procurement Policies and Procedures, a method of purchasing

not requiring competitive sealed bids or competitive negotiation for single or term contracts for goods and services other than professional services if the aggregate or the sum of all phases is not expected to exceed \$50,000; and also allowing for single or term contracts for professional services without requiring competitive negotiation, provided the aggregate or the sum of all phases is not expected to exceed \$50,000.

- o. Solicitation: The process of notifying prospective Bidders or Offerors that the County wishes to receive Bids or Proposals on a set of requirements to provide Goods or Services. "Solicitation" includes any notification of the County requirements may consist of public advertising (newspaper, County's website, or other electronic notification), the mailing of notices of Solicitation, any Invitation for Quotes ("IFQ"), Initiations to Bid ("IFB"), or Requests for Proposal ("RFQ"), the public posting of notices, issuance of an Open Market Procurement ("OMP"), or telephone calls to prospective Bidders or Offerors.
- p. State: The Commonwealth of Virginia.

3. **AUTHORITY**: The Purchasing Agent shall serve as the principal public purchasing official for the County, and shall be responsible for the procurement of goods, services, insurance and construction in accordance with the County's Procurement Policies and Procedures. The Purchasing Agent has responsibility and authority for negotiating, placing and when necessary modifying every Solicitation, Contract and purchase order issued by the County under the County's Small Purchasing Procedures. The Purchasing Agent has signatory authority to bind the County to all contracts and purchases made lawfully under the County's Small Purchasing Procedures. The Purchasing Agent has responsibility and authority for negotiating, placing and when necessary modifying every other Solicitation, Contract and purchase order issued by the County except that the Purchasing Agent has signatory authority to bind the County to all other contracts and purchases ONLY after the contracts or purchases have been adopted and approved by a vote of the Fluvanna County Board of Supervisors (the "Board").

Unless specifically delegated by the Board or the Purchasing Agent, and consistent with the limited authority granted thereto, no other County officer or employee is authorized to order supplies or Services, enter into purchase negotiations or Contracts, or in any way obligate the County for any indebtedness. Any purchase or contract made which is contrary to such authority shall be of no effect and void and the County shall not be bound thereby.

For convenience, the County's Purchasing Officer shall serve as an intermediary between the Purchasing Agent and the Bidder or Contractor and any Bidder or Contractor may direct communications regarding any purchase, Solicitation or Contract to the Purchasing Officer; however as stated *supra* only the Board or County's Purchasing Agent can bind the County and only upon the conditions stated *supra*.

CONDITIONS OF BIDDING

4. **COMPETITION INTENDED**: It is the County's intent to encourage and permit open and competitive bidding in all Solicitations. It shall be the Bidder's responsibility to advise the County in writing if any language, requirement, specification, etc., or any combination thereof, stifles competition or inadvertently restricts or limits the requirements stated in a Solicitation to a single source. The County must receive such notification not later than seven (7) business days prior to the deadline set for acceptance of the Bids. In submitting a Bid, the Bidder guarantees

that he or she has not been a party with other Bidders to an agreement to bid a fixed or uniform price. Violation of this implied guarantee shall render the Bid of any Bidder involved void.

5. **DISCRIMINATION PROHIBITED:** Pursuant to Virginia Code § 2.2-4310, the County does not discriminate against Bidders, Offerors or Contractors because of race, religion, color, sex, national origin, age, disability, status as a service disabled veteran, or any other basis prohibited by state law relating to discrimination in employment. Whenever solicitations are made, the County shall include businesses selected from a list made available by the Department of Small Business and Supplier Diversity. Pursuant to Virginia Code § 2.2-4343.1, the County does not discriminate against “faith-based organizations”, being a religious organization that is or applies to be a contractor to provide goods or services for programs funded by the block grant provided pursuant to the Personal Responsibility and Work Reconciliation Act of 1996, P.L. 104-193.
6. **CLARIFICATION OF TERMS:** Pursuant to Virginia Code § 2.2-4316, if any Bidder has questions or comments about the specifications or other Solicitation documents, the prospective Bidder should contact the County no later than seven (7) business days prior to the date set for the opening of Bids or receipt of Proposals. Any revisions to the Solicitation will be made only by written addendum issued by the County. Notifications regarding specifications may not be considered if received in less than seven (7) business days of the date set for opening of Bids/receipt of Proposals.
7. **MANDATORY USE OF COUNTY FORM AND TERMS AND CONDITIONS:** Unless otherwise specified in the Solicitation, all Bids must be submitted on the forms provided by the County, including but not limited to, a Cover Sheet or Pricing Schedule, if applicable, properly signed in ink in the proper spaces and submitted in a sealed envelope or package. Unauthorized modification of or additions to any portion of the Solicitation may be cause for rejection of the Bid. However, the County reserves the right to decide, on a case by case basis, in its sole discretion, whether to reject any Bid or Proposal which has been modified. These General Conditions are mandatory provisions of all Solicitations and all Contracts of the County.
8. **LATE BIDS & MODIFICATION OF BIDS:** Any Bid or modification thereto received at the office designated in the Solicitation after the exact time specified for receipt of the Bid is considered a late Bid or modification thereof. The County is not responsible for delays in the delivery of the mail by the U.S. Postal Service, private carriers or the inter-office mail system. It is the sole responsibility of the Bidder to ensure their Bid reaches County by the designated date and hour. The following rules apply to all Bids submitted to the County:
 - a. The official time used in the receipt of Bids/Proposals is that time on the automatic time stamp machine in the Finance Department;
 - b. Late Bids or modifications thereof will be returned to the Bidder UNOPENED, if Solicitation number, due date and Bidder’s return address is shown on the container;
 - c. If a Bid is submitted on time, however a modification thereto is submitted after the due date and time, then the County in its sole discretion may choose to consider the original Bid except that the County may not consider such original Bid if the Bid is withdrawn by the Bidder pursuant to Section 9 below; and
 - d. If an emergency or unanticipated event or closing interrupts or suspends the County’s normal business operations so that Bids cannot be received by the exact time specified in the Solicitation, then the due date/time specified for receipt of Bids will be deemed to be extended to the same time of day specified in the Solicitation on the first work day on which normal County business operations resume.

9. WITHDRAWAL OF BIDS:

- a. Pursuant to Virginia Code § 2.2-4330, a Bidder for a public construction contract, other than a contract for construction or maintenance of public highways, may withdraw his Bid from consideration if the price bid was substantially lower than the other Bids due solely to a mistake in the Bid, provided the Bid was submitted in good faith, and the mistake was a clerical mistake as opposed to a judgment mistake, and was actually due to an unintentional arithmetic error or an unintentional omission of a quantity of work, labor or material made directly in the compilation of a Bid, which unintentional arithmetic error or unintentional omission can be clearly shown by objective evidence drawn from inspection of original work papers, documents and materials used in the preparation of the Bid sought to be withdrawn.

If a Bid contains both clerical and judgment mistakes, a Bidder may withdraw his Bid from consideration if the price bid would have been substantially lower than the other Bids due solely to the clerical mistake, that was an unintentional arithmetic error or an unintentional omission of a quantity of work, labor or material made directly in the compilation of a Bid that shall be clearly shown by objective evidence drawn from inspection of original work papers, documents and materials used in the preparation of the Bid sought to be withdrawn. The Bidder shall give notice in writing to the County of his or her claim of right to withdraw his or her Bid within two (2) business days after the conclusion of the Bid opening procedure and shall submit original work papers with such notice.

- b. A Bidder for a Contract other than for public construction may request withdrawal of his or her Bid under the following circumstances:
 - i. Bids may be withdrawn on written request from the Bidder received at the address shown in the Solicitation prior to the time of opening.
 - ii. Requests for withdrawal of Bids after opening of such Bids but prior to award shall be transmitted to the County, in writing, accompanied by full documentation supporting the request. If the request is based on a claim of error, documentation must show the basis of the error. Such documentation may take the form of supplier quotations, Bidder work sheets, etc. If Bid bonds were tendered with the Bid, the County may exercise its right of collection.
- c. No Bid may be withdrawn under this Section 9 when the result would be the awarding of the Contract on another Bid of the same Bidder or of another Bidder in which the ownership of the withdrawing Bidder is more than five percent (5%).
- d. If a Bid is withdrawn under the authority of this Section 9 the lowest remaining Bid shall be deemed to be the low Bid.
- e. No Bidder who, is permitted to withdraw a Bid shall, for compensation, supply any material or labor to or perform any subcontract or other work agreement for the person or firm to whom the Contract is awarded or otherwise benefit, directly or indirectly, from the performance of the project for which the withdrawn Bid was submitted.
- f. The County shall notify the Bidder in writing within five (5) business days of its decision regarding the Bidder's request to withdraw its Bid. If the County denies the withdrawal of a Bid under the provisions of this Section 9, it shall State in such notice the reasons for its

decision and award the Contract to such Bidder at the Bid price, provided such Bidder is a responsible and responsive Bidder. At the same time that the notice is provided, the County shall return all work papers and copies thereof that have been submitted by the Bidder.

- g. Under these procedures, a mistake shall be proved only from the original work papers, documents and materials delivered as required herein. The work papers, documents and materials submitted by the bidder shall, at the bidder's request, be considered trade secrets or proprietary information subject to the conditions of subsection F of Virginia Code § 2.2-4342.

10. ERRORS IN BIDS: When an error is made in extending total prices, the unit Bid price will govern. Erasures in Bids must be initialed by the Bidder. Carelessness in quoting prices, or otherwise in preparation of the Bid, will not relieve the Bidder. Bidders/Offerors are cautioned to recheck their Bids for possible error. Errors discovered after public opening cannot be corrected and the Bidder will be required to perform if his or her Bid is accepted.

11. IDENTIFICATION ON BID ENVELOPE: All Bids, Proposals and requested copies thereof submitted to the County shall be in a separate envelope or package, sealed and identified with the following information clearly marked on the outside of the envelope or package:

- a. Addressed as indicated on page 1 of the solicitation;
- b. Solicitation number;
- c. Title;
- d. Bid due date and time;
- e. Bidder's name and complete mailing address (return address); and
- f. Pursuant to Virginia Code § 2.2-4311.2, the Bidder's identification number issued by the State Corporation Commission, or if the bidder is not required to be authorized to transact business in the Commonwealth as a foreign business entity under Title 13.1 or Title 50 or as otherwise required by law shall include in its bids or proposal a statement describing why the bidder or offeror is not required to be so authorized.

If a Bid is not addressed with the information as shown above, the Bidder takes the risk that the envelope may be inadvertently opened and the information compromised, which may cause the Bid to be disqualified. Bids may be hand delivered to the designated location in the County's offices. No other correspondence or other Proposals/Bids should be placed in the envelope. Any Bidder or Offeror that fails to provide the information required in (f) above shall not receive an award unless a waiver is specifically granted by the County Administrator.

12. ACCEPTANCE OF BIDS: Unless otherwise specified, all formal Bids or Proposals submitted shall be valid for a minimum period of one hundred twenty (120) calendar days following the date established for opening or receipt, respectively, unless extend by mutual agreement of the parties. At the end of the one hundred twenty (120) calendar days the Bid/Proposal may be withdrawn at the written request of the Bidder. Thereafter, unless and until the Proposal is withdrawn, it remains in effect until an award is made or the Solicitation is canceled by the County. The County may cancel any Solicitation at any time by notice of such cancelation to the Bidders.

13. COMPLETENESS: To be responsive, a Bid must include all information required by the Solicitation.

- 14. CONDITIONAL BIDS:** Conditional Bids are subject to rejection in whole or in part.
- 15. RESPONSE TO SOLICITATIONS:** In the event a Bidder cannot submit a Bid on a Solicitation, the Bidder is requested to return the Solicitation cover sheet with an explanation as to why the Bidder is unable to Bid on these requirements, or if there be no cover sheet for the Solicitation a letter to the County explaining the same.
- 16. BIDDER INTERESTED IN MORE THAN ONE BID AND COLLUSION:** More than one bid from an individual, firm, partnership, corporation or association under the same or different name will be rejected. Reasonable grounds for believing that a bidder is interested in more than one bid for the work contemplated will cause rejection of all bids in which the bidder is interested. Any or all bids may be rejected if there is any reason for believing that collusion exists among the bidders. Participants in such collusion may not be considered in future bids for the same work. Each bidder, as a condition of submitting a bid, shall certify that he is not a party to any collusive action as herein defined. However, a party who has quoted prices on work, materials, or supplies to a Bidder is not thereby disqualified from quoting prices to other Bidders or firms submitting a Bid directly for the work, materials or supplies.
- 17. BID OPENING:** Pursuant to Virginia Code § 2.2-4301, all Bids received in response to an IFB will be opened at the date, time and place specified, and announced publicly, and made available for inspection as provided in Section 21 of these General Conditions. Proposals received in response to an RFQ will be made available for inspection as provided in Section 21 of these General Conditions.
- 18. TAX EXEMPTION:** The County is exempt from the payment of any federal excise or any Virginia sales tax. The price bid must be net, exclusive of taxes. Tax exemption certificates will be furnished if requested by the Bidder.
- 19. DEBARMENT STATUS:** By submitting their Bids, Bidders certify that they are not currently debarred from submitting Bids on Contracts by the County, nor are they an agent of any person or entity that is currently debarred from submitting Bids or Proposals on Contracts by the County or any agency, public entity/locality or authority of the State.
- 20. NO CONTACT POLICY:** No Bidder shall initiate or otherwise have contact related to the Solicitation with any County representative or employee, other than the Purchasing Officer or Purchasing Agent, after the date and time established for receipt of Bids. Any contact initiated by a Bidder with any County representative, other than the Purchasing Officer or Purchasing Agent, concerning this Solicitation is prohibited and may cause the disqualification of the Bidder.
- 21. VIRGINIA FREEDOM OF INFORMATION ACT:** As provided under Virginia Code § 2.2-4342, all proceedings, records, Contracts and other public records relating to procurement transactions shall be open to the inspection of any citizen, or any interested person, firm or corporation, in accordance with the Virginia Freedom of Information Act of Virginia Code §§ 2.2-3700 *et seq.*, except:

- a. Cost estimates relating to a proposed procurement transaction prepared by or for the County shall not be open to public inspection;
- b. Any competitive sealed bidding Bidder, upon request, shall be afforded the opportunity to inspect Bid records within a reasonable time after the opening of Bids but prior to award, except in the event that the County decides not to accept any of the Bids and to reopen the Contract. Otherwise, Bid records shall be open to public inspection only after award of the Contract;
- c. Any competitive negotiation Offeror, upon request, shall be afforded the opportunity to inspect Proposal records within a reasonable time after the evaluation and negotiations of Proposals are completed but prior to award except in the event that the County decides not to accept any of the Proposals and to reopen the Contract. Otherwise, Proposal records shall be open to the public inspection only after award of the Contract;
- d. Any inspection of procurement transaction records under this Section 21 shall be subject to reasonable restrictions to ensure the security and integrity of the records;
- e. Trade secrets or proprietary information submitted by a Bidder, Offeror or Contractor in connection with a procurement transaction shall not be subject to public disclosure under the Virginia Freedom of Information Act; however, the Bidder, Offeror or Contractor must invoke the protections of this Section 21 prior to or upon submission of the data or other materials, and must identify the data or other materials to be protected and State the reasons why protection is necessary; and
- f. Nothing contained in this Section 21 shall be construed to require the County, when procuring by “competitive negotiation” (RFQ), to furnish a Statement of reasons why a particular Proposal was not deemed to be the most advantageous to the County.

22. CONFLICT OF INTEREST: Bidder/Contractor certifies by signing any Bid/Contract to/with the County that no conflict of interest exists between Bidder/Contractor and County that interferes with fair competition and no conflict of interest exists between Bidder/Contractor and any other person or organization that constitutes a conflict of interest with respect to the Bid/Contract with the County.

SPECIFICATIONS

23. OMISSIONS OR DISCREPANCIES: Any items or parts of any equipment listed in a Solicitation which are not fully described or are omitted from such specification, and which are clearly necessary for the completion of such equipment and its appurtenances, shall be considered a part of such equipment although not directly specified or called for in the specifications. Should a Bidder find a discrepancy or ambiguity in, or an omission from, the Solicitation, including the drawings and/or specifications, he or she shall so notify the County within twenty-four (24) hours of noting the discrepancy, ambiguity or omission and in any event no less than five (5) days prior to the date set for the opening of Bids. If necessary, the County will send a written addendum for clarification to all Bidders no later than three (3) days before the date set for opening of Bids. Any notification regarding specifications received less than five (5) days prior to the date set for the opening of Bids may or may not be considered by the County in its sole discretion. The Bidder shall abide by and comply with the true intent of the specifications and not take advantage of any unintentional error or omission, but shall fully complete every part

as the true intent and meaning of the specifications and drawings. Whenever the mention is made of any articles, material or workmanship to be in accordance with laws, ordinances, building codes, underwriter's codes, A.S.T.M. regulations or similar expressions, the requirements of these laws, ordinances, etc., shall be construed as to the minimum requirements of these specifications.

24. BRAND NAME OR EQUAL ITEMS: Pursuant to Virginia Code § 2.2-4315, unless otherwise provided in the Solicitation, the name of a certain brand, make or manufacturer does not restrict Bidders to the specific brand, make or manufacturer named; it conveys the general style, type, character, and quality of the article desired, and any article which the County in its sole discretion determines to be the equal of that specified, considering quality, workmanship, economy of operation, and suitability for the purpose intended, shall be accepted. The Bidder is responsible to clearly and specifically indicate the product being offered and to provide sufficient descriptive literature, catalog cuts and technical detail to enable the County to determine if the product offered meets the requirements of the Solicitation. This is required even if offering the exact brand, make or manufacturer specified. Normally in competitive sealed bidding, only the information furnished with the Bid will be considered in the evaluation. Failure to furnish adequate data for evaluation purposes may result in declaring a Bid non-responsive. Unless the Bidder clearly indicates in its Bid that the product offered is "equal" product, such Bid will be considered to offer the brand name product referenced in the Solicitation.

25. FORMAL SPECIFICATIONS: When a Solicitation contains a specification which states no substitutes, no deviation therefrom will be permitted and the Bidder will be required to furnish articles in conformity with that specification.

26. CONDITION OF ITEMS: Unless otherwise specified in the Solicitation, all items shall be new, in first class condition.

AWARD

27. RESPONSIBLE BIDDERS: In determining whether a Bidder is a responsible Bidder as defined herein, at minimum, the following criteria will be considered:

- a. The ability, capacity and skill of the Bidder to perform the Contract or provide the service required under the Solicitation;
- b. Whether the Bidder can perform the Contract or provide the service promptly, or within the time specified, without delay or interference;
- c. The character, integrity, reputation, judgment, experience and efficiency of the Bidder;
- d. The quality of performance of previous Contracts or Services;
- e. The previous and existing compliance by the Bidder with laws and ordinances relating to the Contract or Services;
- f. The sufficiency of the financial resources and ability of the Bidder to perform the Contract or provide the service;

- g. The quality, availability and adaptability of the Goods or Services to the particular use required;
- h. The ability of the Bidder to provide future maintenance and service for the use of the subject of the Contract;
- i. The number and scope of the conditions attached to the Bid;
- j. Whether the Bidder is in arrears to the County on debt or Contract or is a defaulter on surety to the County or whether the Bidder's County taxes or assessments are delinquent; and
- k. Such other information as may be secured by the County, the Purchasing Agent or the Purchasing Officer having a bearing on the decision to award the Contract. If an apparent low Bidder is not awarded a Contract for reasons of nonresponsibility, the County shall so notify that Bidder and shall have recorded the reasons in the Solicitation or Contract file.

28. AWARD OR REJECTION OF BIDS; WAIVER OF INFORMALITIES: The County shall award the Contract to the lowest responsive and responsible Bidder complying with all provisions of the IFB, provided the Bid price is reasonable and it is in the best interest of the County to accept it. Awards made in response to a RFQ will be made to the highest qualified Offeror whose Proposal is determined, in writing, to be the most advantageous to the County taking into consideration the evaluation factors set forth in the RFQ. The County reserves the right to award a Contract by individual items, in the aggregate, or in combination thereof, or to reject any or all Bids and to waive any informality in Bids received whenever such rejection or waiver is in the best interest of the County. Award may be made to as many Bidders/Offerors as deemed necessary to fulfill the anticipated requirements of the County. The County also reserves the right to reject the Bid if a Bidder is deemed to be a non-responsible Bidder. Pursuant to Virginia Code § 2.2-4319, an IFB, a RFQ, any other solicitation, or any and all bids or proposals, may be canceled or rejected by the County at any time. The reasons for cancellation or rejection shall be made part of the contract file. The County shall not cancel or reject an IFB, a RFQ, any other solicitation, bid or proposal solely to avoid awarding a contract to a particular responsive and responsible bidder or offeror.

29. EXCLUSION OF INSURANCE BIDS PROHIBITED: Pursuant to Virginia Code § 2.2-4320, notwithstanding any other provision of law or these General Conditions, no insurer licensed to transact the business of insurance in the State or approved to issue surplus lines insurance in the State shall be excluded from presenting an insurance bid proposal to the County in response to a RFQ or an IFB; excepting that the County may debar a prospective insurer pursuant to its Debarment Policy, see Chapter 2 of the County's Procurement Policies and Procedures.

30. ANNOUNCEMENT OF AWARD: Upon the award or announcement of the decision to award a Contract as a result of this Solicitation, the County will publicly post such notice on the County's bulletin board located at 72 Main Street, 2nd Floor, Palmyra, Virginia 22963. Award results may also be viewed on the County's website.

31. QUALIFICATIONS OF BIDDERS OR OFFERORS: The County may make such reasonable investigations as deemed proper and necessary to determine the ability of the Bidder to perform the work/furnish the item(s) and the Bidder shall furnish to the County all such information and data for this purpose as may be requested. The County reserves the right to inspect Bidder's physical facilities prior to award to satisfy questions regarding the Bidder's capabilities. The County further reserves the right to reject any Bid or Proposal if the evidence submitted by or

investigations of, such Bidder fails to satisfy the County that such Bidder is properly qualified to carry out the obligations of the Contract and to complete the work/furnish the item(s) contemplated therein.

32. TIE BIDS AND PREFERENCE FOR VIRGINIA PRODUCTS WITH RECYCLED CONTENT AND FOR VIRGINIA FIRMS:

- a. Pursuant to Virginia Code § 2.2-4328, in the case of a tie bid on an IFB only, the County may give preference to Goods, Services and construction produced in Fluvanna County or provided by persons, firms or corporations having principal places of business in Fluvanna County. If such choice is not available, preference shall then be given to Goods produced in Virginia, or for goods, services or construction provided by Virginia persons, firms, corporations, pursuant Virginia Code § 2.2-4324. If no County or State choice is available, the tie shall be decided publicly by lot. The decision by the County to make award to one or more such Bidders shall be final.
- b. Whenever the lowest responsive and responsible bidder is a resident of any other state and such state under its laws allows a resident contractor of that state a percentage preference, a like preference shall be allowed to the lowest responsive and responsible bidder who is a resident of Virginia and is the next lowest bidder. If the lowest responsive and responsible bidder is a resident of any other state and such state under its laws allows a resident contractor of that state a price-matching preference, a like preference shall be allowed to responsive and responsible bidders who are residents of Virginia. If the lowest bidder is a resident contractor of a state with an absolute preference, the bid shall not be considered. The Department of General Services shall post and maintain an updated list on its website of all states with an absolute preference for their resident contractors and those states that allow their resident contractors a percentage preference, including the respective percentage amounts. For purposes of compliance with this Section 32, the County may rely upon the accuracy of the information posted on this website.
- c. Notwithstanding the provisions of subsections a and b, in the case of a tie bid in instances where goods are being offered, and existing price preferences have already been taken into account, preference shall be given to the bidder whose goods contain the greatest amount of recycled content.
- d. For the purposes of this Section 32, a Virginia person, firm or corporation shall be deemed to be a resident of Virginia if such person, firm or corporation has been organized pursuant to Virginia law or maintains a principal place of business within Virginia.

33. NEGOTIATION WITH LOWEST RESPONSIBLE BIDDER: Pursuant to Virginia Code § 2.2-4318, unless cancelled or rejected, a responsive Bid from the lowest responsible Bidder shall be accepted as submitted, except that if the Bid from the lowest responsible Bidder exceeds available funds, the County may negotiate with the apparent low Bidder to obtain a Contract price within available funds. However, the negotiation may be undertaken only under conditions and procedures described in writing and approved by the County prior to issuance of the IFB and summarized therein.

CONTRACT PROVISIONS

- 34. APPLICABLE LAW AND COURTS:** Any Bid or Contract resulting from a Solicitation and its terms, including, but not limited to, the parties' obligations under it, and the remedies available to each party for breach of it, shall be governed by, construed and interpreted in accordance with the laws of the Commonwealth of Virginia, and exclusive jurisdiction and venue of any dispute or matters involving litigation between the parties hereto shall be in the courts of Fluvanna County, Virginia. Any jurisdiction's choice of law, conflict of laws, rules, or provisions, including those of the Commonwealth of Virginia, that would cause the application of any laws other than those of the Commonwealth of Virginia, shall not apply. The Contractor shall comply with applicable federal, State and local laws, ordinances, rules and regulations in performance of the Contract.
- 35. PROVISION AND OWNERSHIP OF INFORMATION:** The County shall make a good faith effort to identify and make available to the Contractor all non-confidential technical and administrative data in the County's possession which the County may lawfully release including, but not limited to Contract specifications, drawings, correspondence, and other information specified and required by the Contractor and relating to its work under any Contract. The County reserves its rights of ownership to all material given to the Contractor by the County and to all background information documents, and computer software and documentation developed by the Contractor in performing any Contract.
- 36. DOCUMENTS:** All documents, including but not limited to data compilations, drawings, reports and other material, whether in hard copy or electronic format, prepared, developed or furnished by the Contractor pursuant to any Contract shall be the sole property of the County. At the direction of the County, the Contractor shall have the right to make copies of the documents produced available to other parties. The County shall be entitled to delivery of possession of all documents, upon payment in accordance with the terms of any Contract for the service incurred to produce such documents.
- 37. CONFIDENTIALITY:** Contractor shall not publish, copyright or otherwise disclose or permit to be disclosed or published, the results of any work performed pursuant to this contract, or any particulars thereof, including forms or other materials developed for the County in connection with the performance by Contractor of its services hereunder, without prior written approval of the County. Contractor, cognizant of the sensitive nature of much of the data supplied by the County, shall not disclose any information (other than information which is readily available from sources available to the general public) obtained by it in the course of providing services hereunder without the prior written approval of the County, unless disclosure of such information by it is required by law, rule or regulation or the valid order of a court or administrative agency.
- 38. INDEPENDENT CONTRACTOR:** The Contractor and any agents, or employees of the Contractor, in the performance of any Contract shall act as an independent contractor and not as officers, employees or agents of the County.
- 39. INSURANCE:** The Contractor agrees that, during the period of time it renders services to the County pursuant to any Contract, it shall carry (and provide the County with evidence of coverage) the following minimum amounts of insurance:

Automobile	\$500,000	Liability Medical Payment Comprehensive Collision
Public Liability	\$1,000,000	

Professional Liability	\$1,000,000	
Excess Liability	\$2,000,000	Aggregate Over Above Policy Limits (Excluding Professional Liability)

Worker's Compensation Amount required by Virginia law

The Contract may specifically require the Contractor to carry higher minimum amounts of insurance.

In addition, the Contractor shall require, and shall include in every subcontract, that any subcontractor providing any goods or services related to such Contract obtain, and continue to maintain for the duration of the work, workers' compensation coverage in the amount required by Virginia law.

- 40. KEY PERSONNEL:** For the duration of any Contract, the Contractor shall make no substitutions of key personnel unless the substitution is necessitated by illness, death, or termination of employment, or as expressly approved by the County. The Contractor shall notify the County within five (5) calendar days after the occurrence of any of these events and provide the information required by the paragraph below.

The Contractor shall provide a detailed explanation of the circumstances necessitating any proposed substitution, complete resumes for the proposed substitute, and any additional information requested by the County. The proposed substitute should have comparable qualifications to those of the person being replaced. The County will notify the Contractor within fifteen (15) calendar days after receipt of all required information of its approval or disapproval of the proposed substitution.

- 41. SEVERABILITY:** If any term, covenant or provision of these General Conditions or any Contract shall be held to be invalid, illegal or unenforceable in any respect, these General Conditions and any Contract shall remain in effect and be construed without regard to such provision.
- 42. TITLES:** The titles and section headings herein and in any Contract are inserted solely for convenience and are not to be construed as a limitation on the scope of the provisions to which they refer.
- 43. ATTORNEYS' FEES:** In the event of a dispute between the County and Contractor under any Contract which cannot be amicably resolved, in addition to all other remedies, the party substantially prevailing in any litigation shall be entitled to recover its reasonable expenses, including, but not limited to, reasonable attorneys' fees.
- 44. NO WAIVER:** Neither any payment for, nor acceptance of, the whole or any part of the services by the County, nor any extension of time, shall operate as a waiver of any provision of any Contract, nor of any power herein reserved to the County, or any right to damages herein provided, nor shall any waiver of any breach of any Contract be held to be a waiver of any other or subsequent breach. Failure of the County to require compliance with any term or condition of any Contract shall not be deemed a waiver of such term or condition or a waiver of the subsequent enforcement thereof.
- 45. NO FINANCE CHARGES:** No finance charges shall be paid by the County.

46. ANTITRUST: By entering into a Contract, the Contractor conveys, sells, assigns, and transfers to the County all rights, title and interest in and to all causes of the action it may now have or hereafter acquire under the antitrust law of the United States or the State, relating to the particular Goods or Services purchased or acquired by the County under said Contract. Consistent and continued tie bidding could cause rejection of Bids by the County and/or investigation for antitrust violations.

47. PAYMENT: Pursuant to Virginia Code § 2.2-4352, unless more time is provided in the Solicitation or Contract, payment will be made forty-five (45) days after receipt by the County of a proper invoice, or forty-five (45) days after receipt of all Goods or acceptance of work, whichever is later. The County reserves the right to withhold any or all payments or portions thereof for Contractor's failure to perform in accordance with the provision of the Contract or any modifications thereto. Within twenty (20) days of receipt of proper invoice or of goods or services, the County shall notify the Contractor if any defect or impropriety that would prevent payment by the payment date. The following provisions apply to such payments:

- a. Invoices for items/Services ordered, delivered/performed and accepted shall be submitted by the Contractor in duplicate directly to the payment address shown on the purchase order, Solicitation or Contract, as applicable. All invoices shall show the Contract number, purchase order number, or Solicitation number, as applicable, and as required under Virginia Code § 2.2-4354, either the individual Contractor's social security number or the Contractor's federal employer identification number, whichever is applicable.
- b. Any payment terms requiring payment in less than forty-five (45) days will be regarded as requiring payment forty-five (45) days after receipt of proper invoice or receipt of all Goods or acceptance of work, whichever occurs later. Notwithstanding the foregoing, offers of discounts for payment in less than forty-five (45) days are valid and enforceable.
- c. Pursuant to Virginia Code § 2.2-4353, the date any payment shall be deemed the date of postmark in all cases where payment is made by mail.
- d. The County's fiscal year is July 1 to June 30. Contractors are advised to submit invoices, especially for Goods and/or Services provided in the month of June, for the entire month (i.e. June 1 - June 30), so that expenses are recognized in the appropriate fiscal year.
- e. Any payment made by the Contractor to the County shall only be made in U.S. Dollars. If payment is received in foreign currency the County may, in its sole discretion, reject such payment and require immediate compensation in U.S. Dollars.

48. SUBCONTRACTORS: Pursuant to Virginia Code § 2.2-4354, in the event that any subcontractors are used by Contractor in connection with the work, Contractor shall:

- a. Within seven (7) days after receipt of amounts paid to the Contractor for work performed by a subcontractor, either:
 - i. Pay the subcontractor for the proportionate share of the total payment received attributable to the work performed by the subcontractor under any Contract; or
 - ii. Notify the County and subcontractor, in writing, of his intention to withhold all or a part of the subcontractor's payment with the reason for nonpayment.

- b. Contractor shall require each subcontractor to provide either (i) for an individual, their social security numbers, or (ii) for proprietorships, partnerships, and corporations to provide their federal employer identification numbers.
- c. The Contractor shall pay interest to any subcontractor on all amounts owed by the Contractor that remain unpaid after seven days following receipt by the Contractor of payment from the County for work performed by the subcontractor under any Contract, except for amounts withheld as allowed in subdivision (a)(II) above. Unless otherwise provided under the terms of any Contract, interest shall accrue at the rate of one percent (1%) per month.
- d. The Contractor shall include in each of its subcontracts under any Contract a provision requiring each subcontractor to include or otherwise be subject to the above payment and interest requirements (a), (b) and (c) with respect to each lower tier subcontractor.
- e. The Contractor's obligation to pay an interest charge to a subcontractor pursuant to the payment clause in this Section 48 shall not be construed to be an obligation of the County. No Contract modification may be made for the purpose of providing reimbursement for such interest charge. No cost reimbursement claim may include any amount for reimbursement for such interest charge.

49. RETAINAGE ON CONSTRUCTION CONTRACTS: Pursuant to Virginia Code 2§ 2.2-4333, if a Contract for construction provides for progress payments in installments based upon an estimated percentage of completion, then the contractor shall be paid at least ninety-five percent (95%) of the earned sum when payment is due, with no more than five percent (5%) being retained to ensure faithful performance of the contract. All amounts withheld may be included in the final payment. Any subcontract related to work on a Contract that provides for similar progress payments shall be subject to the provisions above and the Contractor agrees to include such provisions in every subcontract.

50. SUCCESSORS AND ASSIGNS: The County and the Contractor bind themselves and their respective successors and assigns to any Contract. The foregoing notwithstanding, the Contractor shall not assign, sublet or transfer its interest in any Contract without the prior written consent of the County, which may be granted or withheld in the County's sole discretion. Nothing hereinafter mentioned shall be construed as creating any personal liability on the part of any officer, agent or employee of the County, nor shall it be construed as giving any benefits hereunder to anyone other than the County and the Contractor.

51. DEFAULT: Failure of a Contractor to deliver Goods or Services in accordance with Contract terms and conditions and/or within the time specified, or within reasonable time as interpreted by the County in its sole discretion, or failure to make replacements/corrections of rejected articles/services when so requested, immediately or as directed by the County, or failure of the Contractor to act in accordance with the Contract in any material respect, as reasonably determined by the County, shall constitute a "default" by the Contractor and shall further authority for the County to purchase in the open market articles/services of comparable grade/quality to replace the services, articles rejected, and/or not delivered. On all such purchases, the Contractor shall reimburse the County, within a reasonable time specified by the County, for any expense incurred in excess of Contract prices including, but not limited to, any purchase and administrative costs. Such purchases shall be deducted from the Contract quantities, if applicable. Should public necessity demand it, the County reserves the right to use or consume articles delivered or services performed which are substandard in quality, subject to

an adjustment in price to be determined by the County. In case of any default, the County, after due oral or written notice if required in accordance with the Contract, may terminate the Contract at its option in its sole discretion effective immediately. These remedies shall be in addition to any other remedies which the County may have, including but not limited to, any remedies at law, under the Contract or in equity.

Notwithstanding the foregoing, the Contractor shall not be liable for damages for delay in shipment or failure to deliver when such delay or failure is the result of fire, flood, strike, act of God, act of Government, act of an alien enemy or by any other circumstances which, in the County's opinion, are beyond the control of the Contractor. Under such circumstances, however, the County may, at its sole discretion, terminate or cancel the Contract effective immediately.

52. NON-DISCRIMINATION ASSURANCES: The Contractor shall conform to the provisions of the Federal Civil Rights Act of 1964, as amended, as well as the Virginia Fair Employment Act of 1975, as amended, where applicable, and § 2.2-4311 of the Virginia Procurement Act:

- a. During the performance of any Contract, the Contractor agrees as follows: the Contractor will not discriminate against any employee or applicant for employment because of race, religion, color, sex, national origin, age, disability, or other basis prohibited by state law relating to discrimination in employment, except where there is a bona fide occupational qualification reasonably necessary to the normal operation of the Contractor. The Contractor agrees to post in conspicuous places, available to employees and applicants for employment, notices setting forth the provisions of this nondiscrimination clause. The Contractor, in all Solicitations or advertisements for employees placed by or on behalf of the Contractor, will state that such Contractor is an equal opportunity employer. Notices, advertisements and Solicitations placed in accordance with federal law, rule or regulation shall be deemed sufficient for the purpose of meeting the requirements of this Section 52.
- b. The Contractor shall include the provisions of paragraph (a) above in every subcontract or purchase over \$10,000.00 so that the provisions will be binding upon each subcontractor or Vendor.

53. MODIFICATION:

- a. Pursuant to Virginia Code § 2.2-4309, these General Conditions and any Contract entered into by the County and any Contractor shall not be subject to change, modification, or discharge except by written instrument signed by the County and Contractor, but no fixed-price contract may be increased by more than twenty-five percent (25%) of the amount of the contract or \$50,000, whichever is greater, without the advance written approval of the County's Board. In no event may the amount of any contract, without adequate consideration, be increased for any purpose, including, but not limited to, relief of an offeror from the consequences of an error in its bid or offer.
- b. The County may, but is not obligated to, extend the term of an existing contract for services to allow completion of any work undertaken but not completed during the original term of the contract.
- c. Nothing in this Section 53 shall prevent the County from placing greater restrictions on contract modifications.

54. INDEMNIFICATION: Contractor agrees to indemnify, keep and save harmless the County, its officers, agents, officials, employees and volunteers against any and all claims, claims of injuries, death, damage to property, patent claims, suits, liabilities, judgments, losses, costs and expenses, including but not limited to costs of investigation, all reasonable attorneys' fees (whether or not litigation results), and the cost of any appeal, occurring or arising in connection with the Contractor's, its agents', subcontractors', employees', or volunteers' negligence or wrongful acts or omissions in connection with its performance of any Contract. The Contractor shall, at his or her own expense, appear, defend and pay all charges of attorneys and all costs and other expenses arising therefrom or incurred in connection therewith; and if any judgment shall be rendered against the County in any such action, the Contractor shall, at his or her own expenses, satisfy and discharge the same. Contractor expressly understands and agrees that any performance bond or insurance protection required by any Contract, or otherwise provided by the Contractor, shall in no way limit the responsibility to indemnify, keep and save harmless and defend the County as herein provided. Nothing contained in this Solicitation or the Contract shall be deemed to be a waiver of the County's sovereign immunity.

55. DRUG-FREE WORKPLACE: Pursuant to Virginia Code § 2.2-4312, in every Contract over \$10,000.00 the following provisions apply: During the performance of any Contract, the Contractor agrees to (i) provide a drug-free workplace for the Contractor's employees; (ii) post in conspicuous places, available to employees and applicants for employment, a Statement notifying employees that the unlawful manufacture, sale, distribution, dispensation, possession, or use of a controlled substance or marijuana is prohibited in the Contractor's workplace and specifying the actions that will be taken against employees for violations of such prohibition; (iii) state in all Solicitations or advertisements for employees placed by or on behalf of the Contractor that the Contractor maintains a drug-free workplace; and (iv) include the provisions of the foregoing clauses in every subcontract or purchase order of over \$10,000, so that the provisions will be binding upon each subcontractor or vendor.

For the purposes of this Section, "*drug-free workplace*" means a site for the performance of work done in connection with a specific Contract awarded to a Contractor in accordance with this the VPPA and the County's Procurement Procedures, the employees of whom are prohibited from engaging in the unlawful manufacture, sale, distribution, dispensation, possession or use of any controlled substance or marijuana during the performance of the Contract.

56. TERMINATION: Contracts will remain in force for full periods specified and/or until all articles ordered before date of termination shall have been satisfactorily delivered and accepted and thereafter until all requirements and conditions shall have been met, unless:

- a. Terminated prior to expiration date by satisfactory deliveries of entire Contract requirements;
- b. Terminated by the County upon thirty (30) days written notice to the Contractor at the County's convenience in the County's sole discretion ("termination for convenience"), unless a termination for convenience is specifically and expressly prohibited by the Contract. Any Contract cancellation notice shall not relieve the Contractor of the obligation to deliver and/or perform on all outstanding orders issued prior to the effective date of the termination;
- c. Terminated by the County for cause, default or negligence on the part of the Contractor. However, pursuant to Section 51 of these General Conditions, the County may hold the Contractor responsible for any resulting additional purchase and administrative costs.

There is no advance notice requirement in the event of Termination for Cause and termination is effective immediately upon notice to Contractor of the termination for cause;

- d. Extended upon written authorization of County and accepted by Contractor, to permit ordering of unordered balances or additional quantities at Contract prices and in accordance with Contract terms.

57. APPROPRIATIONS: Notwithstanding any other provision of any Contract, the payment of the County's obligations under any Contract shall be subject to annual appropriations by the Board of Supervisors of the County in each fiscal year of monies sufficient to satisfy the same.

58. REFERENCES TO VIRGINIA LAW: Any reference in these General Conditions to the Code of Virginia or other relevant Federal, State or local law is incorporated in whole herein by reference as in effect at the time of the Solicitation or Contract as such statutory provisions may be amended or replaced by any statute dealing with the same or similar subject matter.

59. COOPERATIVE PROCUREMENT: Except as prohibited by the current Code of Virginia, all resultant Contracts will be extended to other Public Bodies of the Commonwealth of Virginia, to permit their ordering of Goods, supplies and/or Services at the prices and terms of the resulting Contract ("cooperative procurement"). By submitting any Bid or entering into any Contract with the County a Bidder/Contractor expressly authorizes cooperative procurement under Virginia Code § 2.2-4304 to the full extent permitted by law. If any other public body decides to use any Contract, the Contractor must deal directly with that public body concerning all matters relating thereto, including but not limited to, the placement or orders, issuance of the purchase order, contractual disputes, invoicing and payment. The County acts only as the "Contracting Agent" for these public bodies. Any resulting contract with other public bodies shall be governed by the laws of that specific entity. It is the Contractor's responsibility to notify the public bodies of the availability of the Contract. Fluvanna County shall not be held liable for any direct or indirect costs, damages or other claim of any kind incurred by another public body or any Contractor as a result of any cooperative procurement.

60. AUDIT: The Contractor hereby agrees to retain all books, records and other documents relative to any Contract for five (5) years after final payment, or until audited by the County, whichever is sooner. The County, its authorized agents, and/or County auditors shall have full access to and right to examine any of said materials during said period.

61. GUARANTIES AND WARRANTIES: All guarantees, representations and warranties required shall be furnished by the Contractor and shall be delivered to the Purchasing Agent before final payment on any Contract is made. In addition to any guarantees, representations and warranties required under the Contract, the Contractor agrees to:

- a. Save the County, its agents and employees harmless from liability of any nature or kind for the use of any copyrighted or un-copyrighted composition; secret process, patented or unpatented; invention; article or appliance furnished or used in the performance of a Contract for which the Contractor is not the patentee, assignee, licensee or owner;
- b. Protect the County against latent defective material or workmanship and to repair or replace any damages or marring occasioned in transit or delivery;

- c. Furnish adequate protection against damage to all work and to repair damages of any kind to the building or equipment, to the Contractor's own work or to the work of other contractors, for which the Contractor's workers are responsible;
- d. Pay for all permits, licenses and fees and give all notices and comply with all laws, ordinances, rules and regulations of the County; and
- e. Protect the County from loss or damage to County owned property while it is in the custody of the Contractor;
- f. At minimum supply all Goods or Services with the manufacturer's standard warranty, if applicable; and
- g. For any Contract involving Services of any nature, the Contractor further agrees to:
 - i. Enter upon the performance of Services with all due diligence and dispatch, assiduously press to its complete performance, and exercise therein the highest degree of skill and competence;
 - ii. Allow Services to be inspected or reviewed by an employee of the County at any reasonable time and place selected by the County;
 - iii. Acknowledges that the County shall be under no obligation to compensate Contractor for any Services not rendered in strict conformity with the Contract; and
 - iv. Stipulates that the presence of a County Inspector shall not lessen the obligation of the Contractor for performance in accordance with the Contract requirements, or be deemed a defense on the part of the Contractor for infraction thereof. The Inspector is not authorized to revoke, alter, enlarge, relax, or release any of the requirements of any Contract Any omission or failure on the part of the Inspector to disapprove or reject any work or material shall not be construed to be an acceptance of any such defective work or material.

62. PRICE REDUCTIONS: If at any time after the date of the Bid/Contract the Contractor makes a general price reduction in the comparable price of any material covered by the Contract to customers generally, an equivalent price reduction based on similar quantities and/or considerations shall apply to any Contract for the duration of the Contract period (or until the price is further reduced). Such price reduction shall be effective at the same time and in the same manner as the reduction in the price to customers generally. For purpose of this provision, a "general price reduction" shall mean any horizontal reduction in the price of an article or service offered (1) to Contractor's customers generally, or (2) in the Contractor's price schedule for the class of customers, i.e., wholesalers, jobbers, retailers, etc., which was used as the basis for bidding on this Solicitation. An occasional sale at a lower price, or sale of distressed merchandise at a lower price, would not be considered a "general price reduction" under this provision. The Contractor shall submit his or her invoice at such reduced prices indicating on the invoice that the reduction is pursuant to the "Price Reduction" provision of the Contract documents. The Contractor in addition will within ten (10) days of any general price reduction notify the County of such reduction by letter. FAILURE TO DO SO IS A DEFAULT UNDER THE CONTRACT AND MAY RESULT IN TERMINATION OF THE CONTRACT IN THE COUNTY'S DISCRETION. The Contractor, if requested, shall furnish, within ten (10) days after the end of the Contract period, a statement certifying either (1) that no general price reduction, as defined above, was made after the date of the Bid or Contract, or (2) if any such general price reductions

were made, that as provided above, they were reported to the County within ten (10) days and the County was billed at the reduced prices. Where one or more such general price reductions were made, the statement furnished by the Contractor shall include with respect to each price reduction (1) the date when notice of any such reduction was issued, (2) the effective date of the reduction, and (3) the date when the County was notified of any such reduction.

63. COMPLIANCE WITH IMMIGRATION LAW: Pursuant to Virginia Code § 2.2-4311.1, in every Contract the following provision applies: the Contractor does not, and shall not during the performance of the Contract, knowingly employ an unauthorized alien as defined in the federal Immigration Reform and Control Act of 1986.

64. VIRGINIA STATE CORPORATION COMMISSION: Pursuant to Virginia Code § 2.2-4311.2, Any Bidder or Contractor organized as a stock or non-stock corporation, limited liability company, business trust, or limited partnership or registered as a registered limited liability partnership shall be authorized to transact business in the Commonwealth as a domestic or foreign business entity if so required by Title 13.1 or Title 50 of the Code of Virginia, or as otherwise required by law, at the time of the Bid, Proposal or any response to Solicitation and during the term of the Contract and any Contract renewal. The Contractor shall not allow its existence to lapse or its certificate of authority or registration to transact business in the Commonwealth, if so required, to be revoked or cancelled at any time during the term or any renewal of the Contract. If the Contractor fails to remain in compliance with the provisions of this Section 64, the Contract may become void at the option of the County.

65. CLAIMS PROCEDURE:

- a. The procedure for consideration by the County of contractual claims for any Contract shall be that set forth in Virginia Code § 15.2-1243, *et seq.*
- b. In addition, pursuant to Virginia Code § 2.2-4364, contractual claims, whether for money or other relief, shall be submitted in writing to the County Administrator no later than sixty (60) days after final payment; however, written notice of the Contractor's intention to file such claim shall have been given at the time of the occurrence or beginning of the work upon which the claim is based. Nothing herein shall preclude a Contract from requiring submission of an invoice for final payment within a certain time after completion and acceptance of the work or acceptance of the Goods. Pendency of claims shall not delay payment of amount agreed due in the final payment.
- c. No written decision denying a claim or addressing issues related to the claim shall be considered a denial of the claim unless the written decision is signed by the Board or the County Administrator. The contractor may not institute legal action prior to receipt of the final written decision on the claim unless the County fails to render a decision within ninety (90) days of submission of the claim. Failure of the County to render a decision within ninety (90) days shall not result in the contractor being awarded the relief claimed or in any other relief or penalty. The sole remedy for the County's failure to render a decision within 90 days shall be the contractor's right to institute immediate legal action.
- d. A Contractor may not institute legal action, prior to receipt of the County's decision on the claim, unless the County fails to render such decision within the time specified by law. A failure by the County to render a decision within the time provided by law shall be deemed a final decision denying the claim by the County.

- e. The decision of the Board or the County Administrator shall be final and conclusive unless the Contractor appeals within six (6) months of the date of the final written decision by instituting legal action as provided in Virginia Code § 2.2-4364.
- f. No administrative appeals procedure pursuant to Virginia Code § 2.2-4365 has been adopted for contractual claims by the County.
- g. Nothing herein shall be construed to prevent the County from instituting legal action against any Contractor or Bidder.

66. NOTICES: All written notices required or permitted under any Solicitation, Bid or Contract shall be deemed sufficient if delivered in person to the County Purchasing Agent or Bidder/Contractor, as applicable, or sent by first class mail to the County or Bidder/Contractor at the addresses set forth in the Solicitation, Bid or Contract or at such other address as a party may designate from time to time by notice given in accordance with the terms of this Section 66; except that where a Solicitation, Bid or Contract expressly requires notice to a specific individual or at a specific location, such shall control. Such notices are deemed received when actually delivered to the party or its representative or agent if hand delivered, or one (1) business day after deposited into the United States mail, if mailed.

DELIVERY

67. SHIPPING INSTRUCTIONS-CONSIGNMENT: Unless otherwise specified in the Solicitation or Contract, as applicable, each case, crate, barrel, package, etc., delivered under the Contract must be plainly stenciled or securely tagged, stating the Contractor's name, purchase order number, and delivery address as indicated in the order. Where shipping containers are to be used, each container must be marked with the purchase order number, name of the Contractor, the name of the item, the item number, and the quantity contained therein. Deliveries must be made within the hours of 8:00 a.m. – 3:00 p.m. Deliveries at any other time will not be accepted unless specific arrangements have been previously made with the designated individual at the delivery point. No deliveries will be accepted on Saturdays, Sundays and holidays unless previous arrangements have been made. It shall be the responsibility of the Contractor to insure compliance with these instructions for items that are drop-shipped.

68. RESPONSIBILITY FOR SUPPLIES TENDERED: The Contractor shall be responsible for the materials or supplies covered by the Contract until they are delivered at the designated point. The Contractor shall additionally bear all risk on rejected materials or supplies after notice of rejection is tendered by the County. Rejected materials or supplies must be removed by and at the expense of the Contractor promptly after notification of rejection, unless public health and safety require immediate destruction or other disposal of rejected delivery. If rejected materials are not removed by the Contractor within ten (10) days after date of notification, the County may return the rejected materials or supplies to the Contractor at the Contractor's risk and expense or dispose of them as abandoned property.

69. INSPECTIONS: The County reserves the right to conduct any test/inspection it may deem advisable to assure supplies and Services conform to the specification in the Solicitation, Bid or Contract, as applicable. Inspection and acceptance of materials or supplies will be made after delivery at destinations herein specified unless otherwise stated. Unless otherwise specified in the Contract, if inspection is made after delivery at the destination specified, the County will bear

the expense of inspection except for the value of samples used in case of rejection. Final inspection shall be conclusive except in regard to latent defects, fraud or such gross mistakes as to amount to fraud. Final inspection and acceptance or rejection of the materials or supplies will be made as promptly as practicable, but failure to inspect and accept or reject materials or supplies shall not impose liability on the County for such materials or supplies as are not in accordance with the specifications.

- 70. COMPLIANCE:** Delivery must be made as ordered and in accordance with the Solicitation, Bid or Contract, as applicable, or as directed by the County when not in conflict with the Bid/Contract. The decision as to reasonable compliance with delivery terms shall be final. Burden of proof of delay in receipt of Goods by the purchaser shall rest with the Contractor. Any request for extension of time of delivery from that specified must be approved by the County, such extension applying only to the particular item or shipment affected. Unless otherwise specified in the Contract, should the Contractor be unreasonably delayed by the County, there shall be added to the time of completion a time equal to the period of such delay caused by the County. However, the Contractor shall not be entitled to claim damages or extra compensation for such delay or suspension. These conditions may vary for construction Contracts.
- 71. POINT OF DESTINATION:** All materials shipped to the County must be shipped F.O.B. DESTINATION unless otherwise stated specifically in the Solicitation, Bid or Contract, as applicable. The materials must be delivered to the “Ship To” address indicated on the purchase order or Solicitation, as applicable.
- 72. REPLACEMENT:** Materials or components that have been rejected by the County, in accordance with the terms of the Contract, shall be replaced by the Contractor at no cost to the County.
- 73. DAMAGES:** Any and all damages to property of the “County” that is the direct result of the Contractor, the employees of the Contractor and/or its subcontractors, agents, licensees, successors, or assigns, shall be the sole responsibility of the Contractor. The property shall be repaired to its last known condition prior to the damages and/or replaced at no cost to the County. The County shall approve any and all repairs/replacements prior to acceptance of the repairs/replacement.
- 74. PACKING SLIPS OR DELIVERY TICKETS:** All shipments shall be accompanied by Packing Slips or Delivery Tickets and shall contain the following information for each item delivered:

 - a. Purchase Order Number;
 - b. Name of Article and Stock Number;
 - c. Quantity Ordered;
 - d. Quantity Shipped;
 - e. Quantity Back Ordered; and

f. The Name of the Contractor.

Contractors are cautioned that failure to comply with these conditions shall be considered sufficient reason for refusal to accept the Goods.

75. ADDITIONAL CHARGES: No delivery charges of any kind shall be added to any invoice; except that (i) if Goods are expressly bought F.O.B. "shipping point" under the Contract and the Contractor prepays transportation, then delivery charges shall be added to invoices; and (ii) if express delivery is authorized and substituted by the County on orders for the method specified in the Contract, then the difference between freight or mail and express charges may be added to invoice.

76. METHOD AND CONTAINERS: Unless otherwise specified, Goods shall be delivered in commercial packages in standard commercial containers, so constructed as to ensure acceptance by common or other carrier for safe transportation to the point of delivery. Containers become the property of the County unless otherwise specified by bidder.

VENDOR DATA SHEET

Note: The following information is required as part of your response to this solicitation. Failure to complete and provide this sheet may result in finding your bid nonresponsive.

1. Qualification: The vendor must have the capability and capacity in all respects to satisfy fully all of the contractual requirements.

2. Vendor's Primary Contact:

Name: _____ Phone: _____

3. Years in Business: Indicate the length of time you have been in business providing this type of good or service:

_____ Years _____ Months

4. Vendor Information:

FIN or FEI Number: _____ If Company, Corporation, or Partnership

5. Indicate below a listing of at least four (4) current or recent accounts, either commercial or governmental, that your company is servicing, has serviced, or has provided similar goods. Include the length of service and the name, address, and telephone number of the point of contact.

Company:	Contact:
Phone:	Email:
Dates of Service:	\$\$ Value:

Company:	Contact:
Phone:	Email:
Dates of Service:	\$\$ Value:

Company:	Contact:
Phone:	Email:
Dates of Service:	\$\$ Value:

Company:	Contact:
Phone:	Email:
Dates of Service:	\$\$ Value:

I certify the accuracy of this information.

Signed: _____ Title: _____ Date: _____

PLEASE RETURN THIS PAGE WITH BID SUBMISSION – [REQUIRED]

PROOF OF AUTHORITY TO TRANSACT BUSINESS IN VIRGINIA

THIS FORM MUST BE SUBMITTED WITH YOUR PROPOSAL/BID. FAILURE TO INCLUDE THIS FORM MAY RESULT IN REJECTION OF YOUR PROPOSAL/BID

Pursuant to Virginia Code §2.2-4311.2, an Offeror/Bidder organized or authorized to transact business in The Commonwealth pursuant to Title 13.1 or Title 50 of the Code of Virginia shall include in its proposal/bid the identification number issued to it by the State Corporation Commission (“SCC”). Any Offeror/Bidder that is not required to be authorized to transact business in the Commonwealth as a foreign business entity under Title 13.1 or Title 50 of the Code of Virginia or as otherwise required by law shall include in its proposal/bid a statement describing why the Offeror/Bidder is not required to be so authorized. Any Offeror/Bidder described herein that fails to provide the required information shall not receive an award unless a waiver of this requirement and the administrative policies and procedures established to implement this section is granted by the County Administrator, as applicable. If this quote for goods or services is accepted by the County of Fluvanna, Virginia, the undersigned agrees that the requirements of the Code of Virginia Section 2.2-4311.2 have been met.

Please complete the following by checking the appropriate line that applies and providing the requested information. ***PLEASE NOTE: The SCC number is NOT your federal ID number or business license number.***

A. _____ Offeror/Bidder is a Virginia business entity organized and authorized to transact business in Virginia by the SCC and such vendor’s Identification Number issued to it by the SCC is _____.

B. _____ Offeror/Bidder is an out-of-state (foreign) business entity that is authorized to transact business in Virginia by the SCC and such vendor’s Identification Number issued to it by the SCC is _____.

C. _____ Offeror/Bidder does not have an Identification Number issued to it by the SCC and such vendor is not required to be authorized to transact business in Virginia by the SCC for the following reason(s):
Please attach additional sheets if you need to explain why such Offeror/Bidder is not required to be authorized to transact business in Virginia.

Legal Name of Company (as listed on W-9) _____

Legal Name of Offeror/Bidder _____

Date _____

Authorized Signature _____

Print or Type Name and Title _____

PLEASE RETURN THIS PAGE WITH BID SUBMISSION – [REQUIRED]

CERTIFICATION OF NO COLLUSION

The undersigned, acting on behalf of _____, does hereby certify in connection with the procurement and proposal to which this Certificate of No Collusion is attached that:

This bid is not the result of, or affected by, any act of collusion with another person engaged in the same line of business or commerce; nor is this bid the result of, or affected by, any act of fraud punishable under Article 1.1 of Chapter 12 of Title 18.1 of the Code of Virginia, 1950, as amended (18.2-498.1 et seq.).

Respectfully submitted this _____ day of _____, 20_____.

Complete if Bidder is an Entity:

WITNESS the following duly authorized signature and seal:

Name of Entity: _____
By: _____ (SEAL)
Signature

Print Name: _____
Print Title: _____

STATE OF _____
COUNTY/CITY OF _____, to-wit:

The foregoing instrument was acknowledged before me this ____ day of _____ (month), _____(year) by _____(Print Name), _____(Print Title) on behalf of _____ (Name of Entity).

Notary Public [SEAL]

My commission expires: _____
Notary registration number: _____

Complete if Bidder is a Sole Proprietor:

Witness the following signature and seal:

Signature (SEAL)

Print Name: _____

STATE OF _____
COUNTY/CITY OF _____, to-wit:

The foregoing instrument was acknowledged before me this ____ day of _____ (month), _____(year) by _____(Print Name), a sole proprietor.

Notary Public [SEAL]

My commission expires: _____
Notary registration number: _____

PLEASE RETURN THIS PAGE WITH BID SUBMISSION - [REQUIRED]

OFFEROR STATEMENT

The undersigned Bidder hereby certifies that the Bidder has carefully examined all instructions, plans, conditions, specifications and other documents or items of this Invitation for Bid and hereby submits this bid pursuant to such instructions, plans, conditions, specifications and other documents or items.

Complete if Bidder is an Entity:

WITNESS the following duly authorized signature and seal:

Name of Entity: _____
By: _____ (SEAL)
Signature
Print Name: _____
Print Title: _____

STATE OF _____
COUNTY/CITY OF _____, to-wit:

The foregoing instrument was acknowledged before me this ____ day of _____ (month), _____ (year) by _____ (Print Name), _____ (Print Title) on behalf of _____ (Name of Entity).

Notary Public [SEAL]

My commission expires: _____
Notary registration number: _____

Complete if Bidder is a Sole Proprietor:

Witness the following signature and seal:

Signature (SEAL)
Print Name: _____

STATE OF _____
COUNTY/CITY OF _____, to-wit:

The foregoing instrument was acknowledged before me this ____ day of _____ (month), _____ (year) by _____ (Print Name), a sole proprietor.

Notary Public [SEAL]

My commission expires: _____
Notary registration number: _____

PLEASE RETURN THIS PAGE WITH BID SUBMISSION - [REQUIRED]

APPENDIX 5 - RFQ QUESTIONNAIRE

1. General Information:

- a. Firm Name: _____
- b. SCC Id: _____
- c. Street Address: _____
- d. Telephone Number: _____
- e. Contact Person: _____
- f. State Contractor's License Number: _____
- g. Employee Registered with the Virginia Board for Contractors: _____
 - i. Class A ___yes (required)
 - ii. Architect or Engineer licensed in Virginia on project team ___yes (required)
- h. Check type of organization:
 - Corporation ___ Individual ___
 - Joint Venture ___ Other ___
 - Partnership ___ If other please specify _____
- i. If a corporation or limited liability company
 - State of Incorporation/formation: _____
 - Date of Incorporation/formation: _____
 - Federal I.D. #: _____
 - Officers/Managers (list all):

Name	Years in Position
_____	_____
_____	_____
_____	_____
_____	_____
- j. If a Partnership
 - Date organized: _____ Type of partnership: _____
 - List of General Partners:

Partners Name	Years as Partner
_____	_____
_____	_____
- k. If individually owned - Years in Business: _____

APPENDIX 5 - RFQ QUESTIONNAIRE

- l. Have you ever operated under another name? **Yes** ___ **No** ___
- i. If yes, what name: _____
- m. Are you properly registered to transact business in Virginia? **Yes** ___ **No** ___
- n. Has your firm declared bankruptcy or initiated bankruptcy proceedings in the past seven years?
Yes ___ **No** ___
2. **Bonding Information:** A bid bond, and payment and performance bonds will be required for this project at the sole cost and expense of the offeror
3. **Judgment Information:**
- a. In the last ten years, has your organization, or any officer, director, partner or owner, had judgments entered against it or them for the breach of contracts? **Yes** ___ **No** ___
4. **Convictions and Debarment Information:** If you answer yes to any of the following, please on a separate attachment, state the person or entity against whom the conviction or debarment was entered, give the location and date of the conviction or debarment, describe the project involved, and explain the circumstances relating to the conviction or debarment, including the names, addresses and phone numbers of persons who might be contacted for additional information.
- a. In the last ten years, has your organization or any officer, director, partner, owner, project manager, procurement manager or chief financial officer of your organization:
- i. Ever been fined or adjudicated of having failed to abate a citation for building code violations by a court or local building code appeals board? **Yes** ___ **No** ___
- ii. Ever been found guilty on charges relating to conflicts of interest? **Yes** ___ **No** ___
- iii. Ever been convicted on criminal charges relating to contracting, construction, bidding, bid rigging or bribery? **Yes** ___ **No** ___
- iv. Ever been convicted: (i) under Va. Code Section 2.2-4367 et seq. (Ethics in Public Contracting); (ii) under Va. Code Section 18.2-498.1 et seq. (Va. Governmental Frauds Act); (iii) under Va. Code Section 59.1-68.6 et seq. (Conspiracy to Rig Bids); (iv) of a criminal violation of Va. Code Section 40.1-49.4 (enforcement of occupational safety and health standards); or (v) of violating any substantially similar federal law or law of another state? **Yes** ___ **No** ___
- v. Ever been convicted on charges relating to employment of illegal aliens on construction projects? **Yes** ___ **No** ___
- b. Is your organization or any officer, director, partner or owner currently debarred from doing federal, state or local government work? **Yes** ___ **No** ___
5. **Compliance Information:** If you answer yes to any of the following, please on a separate attachment give the date of the termination order, or payment, describe the project involved, and explain the circumstances relating to same, including the names, addresses and phone numbers of persons who might be contacted for additional information.
- a. Has your organization:
- i. Ever been terminated on a contract for cause? **Yes** ___ **No** ___

APPENDIX 5 - RFQ QUESTIONNAIRE

- ii. Within the last five years, made payment of actual and/or liquidated damages for failure to complete a project by the contracted date? **Yes** ___ **No** ___
- b. Has your organization, in the last three years, received a final order for willful and/or repeated violation(s) for failure to abate issued by the United States Occupational Safety and Health Administration or by the Virginia Department of Labor and Industry or any other government agency? **Yes** ___ **No** ___
- c. Have any Performance or Payment Bond claims ever been paid by any surety on behalf of your organization? **Yes** ___ **No** ___
- d. Has your organization received more than two (2) cure notices on a single project in the past two (2) years and/or more than one (1) cure notice on five (5) separate projects in the past five (5) years? **Yes** ___ **No** ___
- e. Is your organization registered with eVA, Virginia's electronic procurement system?
Yes ___ **No** ___
- f. If you answered "No" to the eVA question above, does your organization agree to become eVA registered before a contract award? **Yes** ___ **No** ___

6. Company Information:

- a. What approximate, total volume of work in dollars was completed by your organization in the past 24 months? \$ _____
- b. What approximate portion of that work was completed directly by your organization?
\$ _____
- c. Does your organization have more than one office? **Yes** ___ **No** ___
- d. If "Yes" to the above, list the locations of all those offices and indicate which office would run this project.
 - i. Office Locations (listing the office for this project first):
 - 1. _____
 - 2. _____
 - 3. _____
- e. How many people does your organization directly employ? _____
- f. Does your organization have a strong relationship with certain vendors, suppliers, or subcontractors that you would rely upon if awarded a contract? **Yes** ___ **No** ___
- g. If "Yes" to the above, list the companies.
 - i. _____
 - ii. _____
 - iii. _____

Exhibit 1
Exhibit Showing
Conceptual Layout for
Fire Training Building in
Fork Union, Virginia

(for planning purposes only)

March 28, 2018

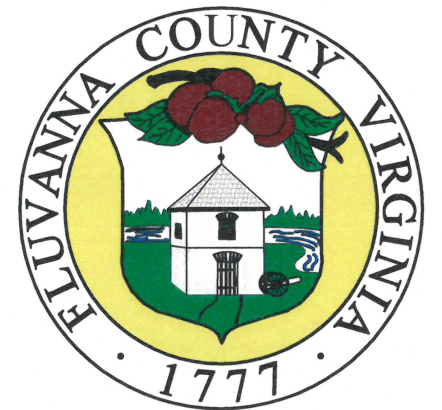

Final location and dimensions
of building, concrete apron
driveway and other site
features to be determined
during site plan preparation.

Scale: NTS (Approx. 1" = 100')



COMMONWEALTH OF VIRGINIA BURN BUILDING PROP PROTOTYPE 2 METAL BUILDING – CLASS B FUEL

Street Address
City, Virginia, Zip Code

OWNER
LOCALITY/MUNICIPALITY

Street Address
City, Virginia Zip Code
Phone:
Fax:

**BURN BUILDING GRANT
FUNDS PROVIDED BY:**
COMMONWEALTH of VIRGINIA
Department of Fire Programs

1005 Technology Park Drive
Glen Allen, VA 23059
Phone: (804) 371-0220

ARCHITECT/ ENGINEER
ARCHITECTURAL OR ENGINEERING FIRM

Street Address
City, State Zip Code
Phone:
Fax:

THIS IS A PROTOTYPICAL DESIGN SET OF
DRAWINGS NOT INTENDED FOR
CONSTRUCTION. THESE DRAWINGS ARE
INTENDED TO BE USED IN CONJUNCTION WITH
THE PROJECT MANUAL AND SPECIFICATIONS
BY AN ARCHITECT/ENGINEER EMPLOYED BY
THE GRANT RECIPIENT IN THE DESIGN OF A
NEW BURN BUILDING PROP.

BUILDING CODE DATA

JURISDICTION:
CITY/COUNTY, VIRGINIA

BUILDING CODE:
A. VIRGINIA UNIFORM STATEWIDE BUILDING CODE
(VUSBC) 2009 EDITION
B. INTERNATIONAL BUILDING CODE (IBC) 2009
EDITION AS AMENDED BY VUSBC

USE GROUP/OCCUPANCY (IBC SECTIONS 304, 311, 1003):

	FLOOR AREA (SQ. FT.)	DENSITY (SQ. FT./PERSON)	OCCUPANTS
BUILDING, GROSS	1881	50	37

*NOTE THE STRUCTURE IS DESIGNED AS A TRAINING PROP AND IS NOT HEATED OR AIR CONDITIONED AND DOES NOT INCLUDE RESTROOMS.

CONSTRUCTION TYPE (IBC SECTION 602):
(II B) NON-COMBUSTIBLE/UNPROTECTED

SPRINKLED:
NOT REQUIRED

HEIGHT/AREA LIMITATIONS (IBC SECTION 503):

TOTAL:	ALLOWABLE:	
A) AREA:	1881 SQ. FT.	8,500 SQ. FT.
B) HEIGHT:	+/- 24'-0" (2 STORY)	40'-0" (2 STORY)

*NOTE: A CODE MODIFICATION REQUEST MUST BE SUBMITTED TO THE BUILDING OFFICIAL FOR CONSTRUCTION OF THIS NON-HABITABLE TRAINING PROP.

INDEX OF DRAWINGS

REFERENCE	TITLE SHEET, BUILDING CODE DATA, & LOCATION MAP	ELECTRICAL	ELECTRICAL FLOOR & ATTIC PLANS, NOTES, SYMBOLS & ABBREVIATIONS
T0.1		E1.0	
A0.1	ABBREVIATIONS, MATERIAL INDICATORS, & GRAPHIC SYMBOLS	E2.0	ELECTRICAL DETAILS & PANELBOARD SCHEDULE
A0.2	GENERAL NOTES		
ARCHITECTURAL	MECHANICAL		
A1.0	SLAB ELEVATION PLAN	M1.0	MECHANICAL PLANS, & NOTES
A2.0	FIRST FLOOR PLAN		
A2.1	SECOND FLOOR PLAN		
A2.2	ATTIC FLOOR & SLOPED ROOF PLANS		
A3.0	BUILDING ELEVATIONS		
A3.1	BUILDING SECTIONS		
A4.0	SCUPPER, RAMP, & THERMAL LINING DETAILS		
A4.1	SIGNAGE, RAILING AND CHOPOUT DETAILS		
STRUCTURAL			
S1.0	FOUNDATION PLAN (BEARING WALL DESIGN) & COLUMN FTG SCHEDULE		
S1.1	FOUNDATION PLAN (MAIN FRAME DESIGN) & COLUMN FTG SCHEDULE		
S2.0	FOUNDATION SECTIONS & DETAILS		
S3.0	EXTERIOR STEEL STAIR ELEVATION, SECTIONS, & DETAILS		

LOCATION MAP



PRIME PROFESSIONAL FIRM LOGO

Project Title
COMMONWEALTH OF VIRGINIA
BURN BUILDING PROP
PROTOTYPE 2
CLASS B FUEL

SUB-CONSULTANT'S LOGO



Department of Fire Programs

NOT FOR CONSTRUCTION

THESE DRAWINGS ARE OWNED BY THE COMMONWEALTH OF VIRGINIA © 2013

No.	REVISIONS	Date

Sheet Title
TITLE SHEET, BUILDING CODE DATA, & LOCATION MAP
CITY/COUNTY VIRGINIA
Drawn By: SJS Approved By: MAM
Checked By: SMF Date: 04/11/13

PROFESSIONAL SEAL

Sheet No.
T0.1
1 of 18

ABBREVIATIONS

ADJ	ADJACENT, ADJUSTABLE	JT	JOINT
AFF	ABOVE FINISHED FLOOR	L	LENGTH
AGG	AGGREGATE	LB(S)	POUND, POUNDS
ANCH	ANCHOR, ANCHORAGE	LTWT CONC	LIGHTWEIGHT CONCRETE
AND	AND/IZED	MATL	MATERIAL
APFD	APPROVED	MAX	MAXIMUM
ARCH	ARCHITECTURAL	MECH	MECHANICAL
ASSOC	ASSOCIATED	MED	MEDIUM
AUTO	AUTOMATIC	MANUF	MANUFACTURER
AUX	AUXILIARY	MIN	MINIMUM
AVG	AVERAGE	MISC	MISCELLANEOUS
BLDG	BUILDING	MTD	MOUNTED
BLK	BLOCK	MTG HT	MOUNTING HEIGHT
BOTT	BOTTOM	MTL	METAL
BR	BURN ROOM	N/A	NOT APPLICABLE
CEM	CEMENT	NEG	NECESSARY
CHK'D	CHECKED	NO	NOT IN CONTRACT
CJ	CONTROL JOINT	NTS	NOT TO SCALE
CL	CENTER LINE	NO#	NUMBER
CLG	CEILING	NOM	NOMINAL
CLR	CLEAR	OC	ON CENTER
COL	COLUMN	OD	OUTSIDE DIAMETER
CONC	CONCRETE	OH	OVERHEAD
CONT	CONTINUOUS	OPENS	OPENING
CONTR	CONTRACTOR	OPP	OPPOSITE
COORD	COORDINATE	PART	PARTITION
CTR	CENTER	P	PLATE
D	DEEP (DEPTH)	PLMBG	PLUMBING
DBL	DOUBLE	PR	PAIR
DEP	DEPRESSION, DEPRESS	PREFAB	PREFABRICATED
DET	DETAIL	PROV	PROVIDE
DIA	DIAMETER	PSF	POUNDS PER SQUARE FOOT
DIM	DIMENSION	PSI	POUNDS PER SQUARE INCH
DN	DOWN	PT	POINT, POINT
DR	DOOR	PVC	POLYVINYL CHLORIDE
DRWG(S)	DRAWING(S)	R	RADIUS, RISER
DWL	DOWNEL	REF	REFLECTED, REFERENCE, REFER
EA	EACH	REINF	REINFORCEMENT
ELEV	ELEVATION	REQ	REQUIRED, REQUIRED
ELECT	ELECTRICAL	REV	REVISE, REVISION
ENCLOS	ENCLOSURE	ROOFG	ROOFING
EQ	EQUAL	RH	RIGHT HAND
EQUIP	EQUIPMENT	RO	ROUGH OPENING
EXP	EXPANSION EXPOSED	RM	ROOM
EJ	EXPANSION JOINT	SCHED	SCHEDULE
EXIST	EXISTING	SEAL	SEALANT
EXT	EXTERIOR	SHT	SHEET
FDN	FOUNDATION	SIM	SIMILAR
FIN	FINISH	SPEC(S)	SPECIFICATION
FLR	FLOOR	SQ	SQUARE
FLEX	FLEXIBLE	SS	STAINLESS STEEL
FRT	FIRE RETARDANT TREATED	STD	STANDARD
FTT)	FEET (FOOT)	STL	STEEL
FTG	FOOTING	STRUC	STRUCTURAL (STRUCTURE)
GA	GAGE	SUSP	SUSPEND, SUSPENDED
GALV	GALVANIZED	T	TOP, THICK
GC	GENERAL CONTRACTOR	T&B	TOP AND BOTTOM
GEN	GENERAL	TEMP	TEMPERED, TEMPORARY, TEMPERATURE
H	HIGH	THK	THICK, THICKNESS
HDR	HARDWARE	THRU	THROUGH
HM	HOLLOW METAL	TS	STRUCTURAL STEEL TUBE OR TOP OF STEEL
HORIZ	HORIZONTAL	TYP	TYPICAL
HP	HIGH POINT	UL	UNDERWRITERS LABORATORIES
HTH)	HEIGHT	UNO	UNLESS NOTED OTHERWISE
IN'	INCH	VERT	VERTICAL
INFO	INFORMATION	V.I.F.	VERIFY IN FIELD
INSUL	INSULATE, INSULATION	WT	WEIGHT
INT	INTERIOR	W/F	WELDED WIRE FABRIC
		W	WIDTH, WIDE
		W'	WITH
		W'	WITHIN
		W/O	WITHOUT
		WP	WORKING POINT

MATERIAL INDICATIONS

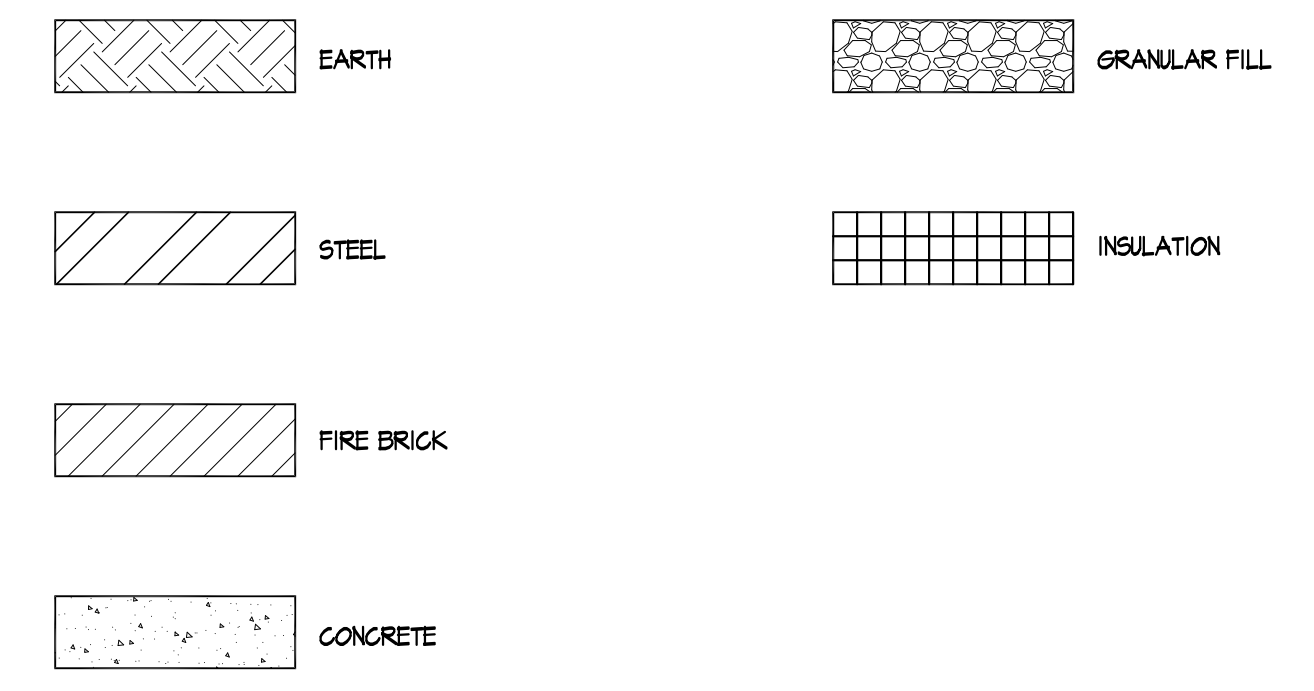

GRAPHIC SYMBOLS

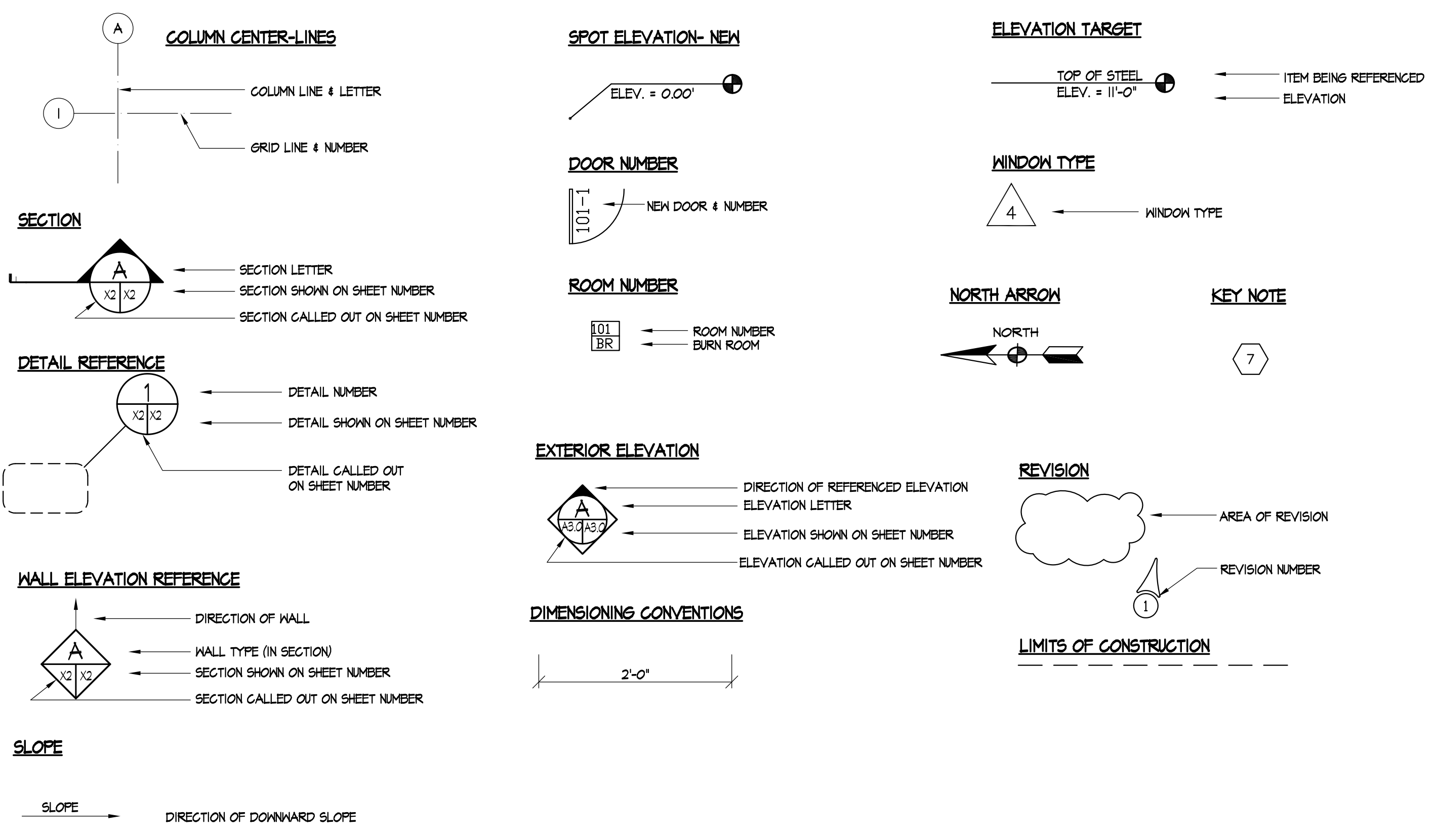

PRIME PROFESSIONAL FIRM LOGO

Project Title
COMMONWEALTH OF VIRGINIA
 BURN BUILDING PROP
 PROTOTYPE 2
 CLASS B FUEL

SUB-CONSULTANT'S LOGO



Department of Fire Programs

NOT FOR CONSTRUCTION
 THESE DRAWINGS ARE OWNED BY THE COMMONWEALTH OF VIRGINIA © 2013

No.	REVISIONS	Date

Sheet Title
ABBREVIATIONS
MATERIAL INDICATORS,
& GRAPHIC SYMBOLS
 CITY/COUNTY VIRGINIA
 Drawn By: SJS Approved By: MAM
 Checked By: SMF Date: 04/11/13

PROFESSIONAL SEAL

Sheet No.
A0.1
 2 of 18

GENERAL NOTES:

GENERAL:

- WORK PERFORMED SHALL COMPLY WITH THE FOLLOWING:
 - THE VIRGINIA UNIFORM STATEWIDE BUILDING CODE (VUBC), 2004 EDITION
 - THE INTERNATIONAL BUILDING CODE (IBC), 2009 EDITION AS AMENDED BY THE VUBC
 - ALL APPLICABLE STATE AND LOCAL CODES, ORDINANCES AND REGULATIONS
- MAINTAIN UTILITY EQUIPMENT IN SERVICE AND PROTECT AGAINST DAMAGE DURING CONSTRUCTION. DO NOT INTERRUPT EXISTING UTILITIES SERVING OCCUPIED OR OPERATING FACILITIES, EXCEPT WHEN AUTHORIZED IN WRITING BY THE BUILDING MANAGER AND AUTHORITIES HAVING JURISDICTION. IF REQUIRED BY THE OWNER, AT THE CONTRACTOR'S EXPENSE, PROVIDE TEMPORARY SERVICES DURING INTERRUPTIONS TO EXISTING UTILITIES. PROVIDE NO LESS THAN 12 HOURS PRIOR NOTICE TO THE OWNER AND THE BUILDING MANAGER IF SHUTDOWN OF SERVICE IS REQUIRED.

DESIGN LOADS:

1. BUILDING CLASSIFICATION CATEGORY	II
2. GROUND SNOW, P _s	30 PSF*
FLAT ROOF SNOW LOAD, P _f	28 PSF*
SNOW EXPOSURE FACTOR, C _e	0.9
SNOW THERMAL FACTOR, C _t	1.2
SNOW IMPORTANCE FACTOR, I	1.0
3. WIND SPEED	110 MPH*
EXPOSURE	C
IMPORTANCE FACTOR, I	1.0
INTERNAL PRESSURE COEFFICIENT	±0.18
4. COMPONENTS AND CLADDING (A = 10 SQFT):	
ROOF WIND LOADING:	
ZONE 1	+12.5, -21.8 PSF*
ZONE 2	+12.5, -26.5 PSF*
ZONE 3	+12.5, -55.0 PSF*
WALL WIND LOADING:	
ZONE 4	+21.8, -29.6.5 PSF*
ZONE 5	+21.8, -24.1 PSF*
5. LIVE LOADS:	
FLAT AND SLOPED ROOFS	UNIFORM 100 PSF
FLOORS	100 PSF
STAIRS	100 PSF
* MINIMUM CONCENTRATED LOAD OF 300 POUNDS ON STAIR TREADS (ON AREA OF 4 SQUARE INCHES)	
RAILINGS	50 PSF UNIFORM OR 200 LB POINT LOAD
EXTERIOR APRON	125 PSF
6. SEISMIC DESIGN:	
SEISMIC IMPORTANCE FACTOR, I	1.0
MAPPED SPECTRAL RESPONSE ACCELERATION, S _s	0.42*
MAPPED SPECTRAL RESPONSE ACCELERATION, S ₁	0.115*
SEISMIC USE GROUP	I
SITE SOIL CLASS	D*
SPECTRAL COEFFICIENT, S _{ds}	0.448*
SPECTRAL COEFFICIENT, S _{d1}	0.184*
SEISMIC DESIGN CATEGORY	C*
BASIC STRUCTURAL SYSTEM	MOMENT FRAME
SEISMIC FORCE RESISTING SYSTEM	M (ASCE 1-05 TABLE 12.2-1)
DESIGN BASE SHEAR	15.8 KIPS*
SEISMIC RESPONSE COEFFICIENT, C _s	0.12*
RESPONSE MODIFICATION COEFFICIENT, R	3
SEISMIC ANALYSIS	EQUIV. LATERAL FORCE PROCEDURE

*VERIFY WITH LOCAL JURISDICTION

ARCHITECTURAL:

- UNLESS NOTED OTHERWISE, ALL PARTITIONS ARE DIMENSIONED TO THE FACE OF FINISHED WALL.
- THE DATUM ELEVATION IS TAKEN AT THE TOP OF THE EXTERIOR APRON SLAB WHERE THE APRON INTERSECTS THE PERIMETER OF THE BUILDING (EXCEPT AT GROUND FLOOR DOORS).
- THE DATUM ELEVATION IS XXX FEET.
- ALL BUILDING ELEVATIONS ARE SHOWN IN THE PLANS AS +XXX OR -XXX IN FEET RELATIVE TO THE DATUM.

FOUNDATIONS:

- CONTRACTOR SHALL NOTIFY "MISS UTILITY" PRIOR TO BEGINNING EXCAVATION FOR LOCATION OF UNDERGROUND UTILITIES.
- EXTERIOR FOOTINGS AND COLUMN FOOTINGS WERE DESIGNED TO BEAR ON UNDISTURBED SOIL BELOW THE FROST LINE A MINIMUM OF 2'-0" BELOW EXISTING GRADE.
- MINIMUM SOIL BEARING PRESSURE IS ASSIGNED TO BE 2,000* PSF AND THE OWNER SHALL EMPLOY A GEOTECHNICAL ENGINEER TO VERIFY THAT THIS ALLOWABLE SOIL BEARING PRESSURE IS ATTAINABLE. IF THIS IS NOT ATTAINABLE, THE OWNER/CONTRACTOR SHALL CONTACT THE ENGINEER FOR REDESIGN.
- SOIL POISONING TREATMENT SHALL BE PROVIDED FOR AREAS BENEATH CONCRETE SLABS ON EARTH AND ALONG INTERIOR SURFACES OF FOUNDATION BY APPLICATOR CERTIFIED TO PERFORM SUCH WORK IN THE STATE OF VIRGINIA. FURNISH OWNER WITH A WRITTEN 5-YEAR INSURED GUARANTEE.
- ALL COLUMN FOOTINGS SHALL BE CENTERED UNDER COLUMN CENTER LINES UNLESS NOTED OTHERWISE.
- ALL UTILITIES WHICH CROSS FOOTINGS MUST PASS ABOVE STRIP FOOTING THROUGH THE FOUNDATION WALL, SLEEVE, PATCH, AND PARGE. STEP FOOTINGS AS REQUIRED. REINFORCING SHALL BE CONTINUOUS AT ALL FOOTING STEPS.
- CONCRETE SLABS ON GRADE SHALL BEAR ON A MINIMUM OF 6" COMPACTED #51 STONE. WHERE REQUIRED, SOIL UNDER FOOTINGS SHALL BE COMPACTED TO AT LEAST 95% OF MAXIMUM DENSITY AS DETERMINED BY ASTM METHOD D-698 (STANDARD PROCTOR).

CONCRETE:

- CONCRETE FOR FOOTINGS SHALL HAVE A MINIMUM COMPRESSIVE STRENGTH OF 3,000 PSI AT 28 DAYS AND A MAXIMUM WATER/CEMENT RATIO OF 0.5.
- CONCRETE FOR FLOOR SLABS, STEM WALL, PEDESTALS AND OTHER ABOVE GROUND CONSTRUCTION SHALL HAVE A MINIMUM COMPRESSIVE STRENGTH OF 5,000* PSI AT 28 DAYS AND A MAXIMUM WATER/CEMENT RATIO OF 0.40* UNLESS NOTED OTHERWISE.
- ALL CONCRETE SHALL BE MIXED, PLACED AND TESTED IN ACCORDANCE WITH THE LATEST EDITION OF ACI 318.
- ALL CONCRETE SHALL HAVE A SLUMP OF 4" ± 1" UNLESS NOTED OTHERWISE.
- CONCRETE MIX DESIGNS SHALL BE SUBMITTED TO THE STRUCTURAL ENGINEER OF RECORD FOR APPROVAL PRIOR TO USE.
- ALL CONCRETE TO BE POURED IN COLD WEATHER, AS DEFINED IN SECTION 11 OF ACI 306R, COLD WEATHER CONCRETING, SHALL FULLY COMPLY WITH ACI 306.1, STANDARD SPECIFICATIONS FOR COLD WEATHER CONCRETING, AND ACI 306R.
- ALL CONCRETE TO BE POURED IN HOT WEATHER, AS DEFINED IN SECTION 1.2 OF ACI 306R, HOT WEATHER CONCRETING, SHALL FULLY COMPLY WITH ACI 306.1, STANDARD SPECIFICATIONS FOR HOT WEATHER CONCRETING, AND ACI 306R.
- REINFORCING BARS SHALL BE ASTM A-615, GRADE 60, EPOXY COATED BARS SHALL BE ASTM A-715 GRADE 60 AS A BID ALTERNATE
- ALL CONCRETE REINFORCING SHALL BE DETAILED AND CONSTRUCTED PER ACI 318.
- CONTRACTOR SHALL SUBMIT REINFORCING SHOP DRAWINGS FOR CONCRETE REINFORCING STEEL FOR APPROVAL.
- ALL CONCRETE REINFORCING STEEL SHALL HAVE CORNER OR "Z" BARS OF THE SAME DIAMETER AT ALL CORNERS AND CHANGES IN DIRECTION. CORNER AND "Z" BARS SHALL LAP CONTINUOUS BARS A MINIMUM OF 48 TIMES THE NOMINAL BAR DIAMETER ON BOTH ENDS.
- ALL CONCRETE SLABS ON GRADE SHALL BE REINFORCED WITH WELDED WIRE FABRIC OF THE SIZE INDICATED ON THE PLANS AND SHALL BE PLACED OVER 6 MIL VAPOR BARRIER UNLESS SHOWN OTHERWISE ON DRAWINGS.
- SAW CUTTING CONTROL JOINTS SHALL BE PERFORMED AS SOON AS THE CONCRETE SLAB ON GRADE IS HARD ENOUGH TO SUPPORT THE CUTTING MACHINE WITHIN FIRST FOUR HOURS OF CURING.
- SLABS ON GRADE INCLUDING THE EXTERIOR APRON SLAB SHALL BE AIR ENTRAINED CONCRETE AND REINFORCED WITH WELDED WIRE FABRIC PLACED ON CONCRETE BLOCKS. AIR ENTRAINMENT FOR SLABS SHALL BE 6% BY VOLUME ± 1%.
- ALL CONCRETE EXCEPT FOOTINGS SHALL BE AIR-ENTRAINED 6% BY VOLUME ± 1% UNLESS SHOWN OTHERWISE ON DRAWINGS.
- CONCRETE PROTECTION FOR STEEL REINFORCEMENT OF CAST-IN-PLACE CONCRETE SHALL BE AS SPECIFIED BELOW:

TYPE OF STRUCTURE	MINIMUM CLEAR COVER (UNLESS OTHERWISE NOTED IN DRAWINGS)
STEM WALL	2"
PEDESTALS	2" TO VERTICAL BARS 1-5/8" TO TIES
FOOTINGS AND OTHER EARTH FORMED CONCRETE	3"

- SPECIAL INSPECTIONS SHALL BE REQUIRED FOR THE CAST IN PLACE CONCRETE MATERIALS AND INSTALLATION, INCLUDING BUT NOT LIMITED TO REINFORCEMENT, BOLTS, FORMWORK, PLACEMENT, CURING AND STRENGTH AS IDENTIFIED IN THE SCHEDULE OF SPECIAL INSPECTIONS.

STRUCTURAL STEEL:

- ALL STRUCTURAL STEEL FRAMING SHALL BE IN ACCORDANCE WITH THE LATEST EDITION OF AISI "MANUAL OF STEEL CONSTRUCTION." ALL STRUCTURAL STEEL BEAM, COLUMN AND CHANNEL SHAPES SHALL BE ASTM A-992. ALL STEEL ANGLES AND PLATES SHALL BE ASTM A-36. ALL STRUCTURAL STEEL TUBES SHALL BE ASTM A500 GRADE B.
- CONTRACTOR TO SUBMIT STRUCTURAL STEEL SHOP DRAWINGS FOR APPROVAL BY THE STRUCTURAL ENGINEER OF RECORD.
- ALL STRUCTURAL STEEL SHOP WORK TO BE WELDED WITH E70XXX ELECTRODES. FIELD WORK CONNECTIONS TO BE BOLTED WITH 3/4" HIGH STRENGTH A325X BOLTS OR WELDED WITH E70XXX ELECTRODES. PRE-DRILL HOLES IN STEEL MEMBERS AS REQUIRED FOR FASTENING, BLOCKING, ETC.
- ALL COLUMNS SHALL BE FURNISHED WITH CAP PLATES AND BASE PLATES OF SIZE CALLED FOR AND SHALL BE SHOP WELDED. BASE PLATES SHALL BEAR ON LEVELING NUTS SET IN 1" THICKNESS OR APPROVED SHRINK RESISTANT GROUT EXCEPT WHEN SHOWN OTHERWISE AND ANCHORED WITH FOUR (4) 3/4" DIAMETER 12" THREADED RODS WITH A WASHER AND DOUBLE NUTS. SHIM UNDER BASE PLATES AS REQUIRED.
- ALL STRUCTURAL STEEL FRAMING TO HAVE ONE SHOP COAT OF RUST INHIBITIVE PAINT AFTER FABRICATION AND ONE FINISH COAT OF APPROVED PAINT UNLESS NOTED OTHERWISE. ALL EXPOSED STEEL TO HAVE TWO (2) COATS OF APPROVED COLOR SELECTED BY OWNER.
- SPECIAL INSPECTIONS SHALL BE REQUIRED FOR THE STRUCTURAL STEEL MATERIALS, QUALITY CONTROL PROGRAM, BOLTS, NUTS AND WASHERS, WELDING, AND STRUCTURAL DETAILS AS IDENTIFIED IN THE SCHEDULE OF SPECIAL INSPECTIONS.

STEEL GRATING AND TREADS:

- STEEL GRATING SHALL BE 2" DEEP, 14 GAUGE, GALVANIZED GRIP STRUT DIAMOND SAFETY GRATING OR EQUIVALENT. INSTALL GRATING IN ACCORDANCE WITH THE MANUFACTURER'S REQUIREMENTS TO CREATE A TWO-SPAN CONDITION BY WELDING. WELD SIDES OF ADJACENT PANELS TOGETHER PER MANUFACTURER'S RECOMMENDATIONS.
- STEEL STAIR TREADS SHALL BE 2" DEEP, 14 GAUGE GALVANIZED GRIP STRUT DIAMOND STAIR TREADS OR EQUIVALENT. INSTALL TREADS IN ACCORDANCE WITH THE MANUFACTURER'S REQUIREMENTS USING STANDARD ZINC COATED BOLTS.

WOOD:

- WOOD FRAMING IS BASED ON DESIGN VALUES NOTED IN THE NATIONAL DESIGN SPECIFICATION FOR WOOD CONSTRUCTION, 2005 EDITION
- RAFTERS FOR CHOP OUT OPENING SHALL BE CONSTRUCTED WITH NO. 2 SOUTHERN YELLOW PINE (SYP) WITH MINIMUM F_b = 1050 PSI AND E = 1,600,000 PSI ALLOWABLE STRESSES.
- ALL PLYWOOD SHALL BE MANUFACTURED AND GRADED IN ACCORDANCE WITH U.S. DEPARTMENT OF COMMERCE (DOC) PRODUCT STANDARD PS1-45 FOR PLYWOOD CONSTRUCTION FROM GROUP 1 SPECIES. EACH PLYWOOD SHEET SHALL BEAR THE "APA" GRADE TRADEMARK.
- PLYWOOD ROOF SHEATHING SHALL CONFORM TO APA C-D RATED EXTERIOR 3/4" MINIMUM THICKNESS PLYWOOD SHEATHING UNLESS NOTED OTHERWISE. PROVIDE APPROPRIATE SPACING BETWEEN JOINTS. USE OF "H" CLIPS REQUIRED ON ROOF SHEATHING.
- THE FACE GRAIN OF THE PLYWOOD SHALL BE LAID AT RIGHT ANGLES TO THE RAFTERS.
- FASTENERS SHALL BE PLACED 3/8" MINIMUM FROM THE EDGE OF THE PLYWOOD SHEETS.
- ALL PLYWOOD END JOINTS SHALL BE STAGGERED AND SHALL BE LOCATED ALONG THE CENTER LINES OF THE FRAMING MEMBERS.
- PLYWOOD USED FOR SLOPED ATTIC ROOF, WITH THE EXCEPTION OF THE CHOP OUT, SHALL BE FIRE RETARDANT TREATED. PLYWOOD AND WOOD FRAMING USED FOR CHOP OUT SHALL NOT BE PRESERVATIVE OR FIRE RETARDANT TREATED.

METAL BUILDING:

- METAL BUILDING MANUFACTURER SHALL BE A MEMBER OF THE METAL BUILDING MANUFACTURERS ASSOCIATION (MEMA). CONTRACTOR SHALL SUBMIT SEALED COMMONWEALTH OF VIRGINIA LICENSED PROFESSIONAL ENGINEER'S STRUCTURAL DESIGN CALCULATIONS AND SHOP DRAWINGS FOR APPROVAL PRIOR TO CONSTRUCTION OF METAL BUILDING FOUNDATION.
- SHOP DRAWINGS SUBMITTAL REQUIREMENTS: SUBMIT COMPLETE ERECTION DRAWINGS SHOWING ANCHOR BOLT SETTINGS, SIDEWALL, ENDWALL AND ROOF FRAMING, TRANSVERSE CROSS SECTIONS, COVERING AND TRIM DETAILS AND ACCESSORY INSTALLATION DETAILS TO CLEARLY INDICATE PROPER ASSEMBLY OF BUILDING COMPONENTS.
- METAL BUILDING MANUFACTURER SHALL PROVIDE A COMPLETE AND PROPERLY INSTALLED SYSTEM AS REQUIRED FOR A WEATHER TIGHT, 20 YEAR WARRANTED BUILDING.
- THE LOCATION OF ANCHOR BOLTS, SIZE OF COLUMN BASE PLATES, LOCATION OF GIRTS, ETC., MUST BE VERIFIED AGAINST MANUFACTURER'S FRAMING ARRANGEMENT. ANY DEVIATIONS MUST BE BROUGHT TO THE ATTENTION OF THE ENGINEER. ALL SUCH DEVIATIONS MUST BE COORDINATED AND APPROVED BEFORE CONCRETE IS PLACED.
- THE CONCRETE PIERS ARE DESIGNED FOR VERTICAL AND LATERAL LOADS. NO MOMENT FROM RIGID FRAME COLUMNS SHALL BE TRANSMITTED TO THE FOUNDATION.
- DESIGN OF THE PRE-ENGINEERED BUILDING TO SUPPORT ROOF, SNOW WIND AND SEISMIC LOADS AS STATED IN THE DESIGN LOADS ABOVE IN ACCORDANCE WITH THE METAL BUILDING MANUFACTURER'S ASSOCIATION. ADDITIONAL LOADS:
 - COLLATERAL ROOF AND FLOOR DEAD LOAD = 5 PSF

EXPANSION ANCHORS:

- ALL ANCHORS SHALL BE INSTALLED IN ACCORDANCE WITH THE RECOMMENDATIONS OF THE MANUFACTURER.
- EXPANSION ANCHORS SHALL BE WEDGE TYPE WITH A SINGLE PIECE THREE SECTION WEDGE. THE ANCHORS SHALL MEET THE DESCRIPTION IN FEDERAL SPECIFICATION FF-5-325, GROUP II, TYPE 4, CLASS I FOR CONCRETE EXPANSION ANCHORS. ANCHORS SHALL BE HILTI KNIK BOLT II, MANUFACTURED BY HILTI FASTENING SYSTEMS, OR EQUIVALENT.
- ALL EXPANSION ANCHORS SHALL BE ZINC PLATED IN ACCORDANCE WITH ASTM B689, SERVICE CONDITION SC I, TYPE III UNLESS INDICATED IN THE DRAWINGS AS STAINLESS STEEL.
- UNLESS OTHERWISE NOTED, THE FOLLOWING MINIMUM REQUIREMENTS SHALL BE MET FOR EXPANSION ANCHORS:

ANCHOR DIAMETER	EMBEDMENT DEPTH	ALLOWABLE LOADS IN CONCRETE	
		TENSION (POUNDS)	SHEAR (POUNDS)
5/8"	2-1/2"	1,570	1,470
1/2"	3-1/2"	2,400	2,450

THERMAL LINING:

- THE THERMAL LINING SHALL BE INSTALLED IN ACCORDANCE WITH THE REQUIREMENTS OF THE MANUFACTURER.
- THE THERMAL LINING SYSTEM SHALL BE DESIGNED TO PROVIDE THE REQUIRED LEVEL OF PROTECTION AS INDICATED IN THE SPECIFICATIONS.

TEMPERATURE MONITORING SYSTEM:

- THE TEMPERATURE MONITORING SYSTEM SHALL CONSIST OF A CENTRAL RECORDER LOCATED IN THE MONITORING EQUIPMENT ROOM AND THERMOCOUPLES AS SHOWN ON ELECTRICAL DRAWINGS, SEE SPECIFICATION FOR REQUIREMENTS.

ELECTRICAL:

- PROVIDE ALL NECESSARY LABOR, EQUIPMENT, ETC. FOR ALL WORK INDICATED AND REQUIRED FOR COMPLETE INSTALLATION TO COMPLY WITH THE 2009 EDITION OF THE INTERNATIONAL ELECTRICAL CONSERVATION CODE, (2009 IECG).
- ELECTRICAL SUB CONTRACTOR TO PROVIDE SYSTEM DESIGN AND PLAN LAYOUT FOR REVIEW AND APPROVAL.
- THE ELECTRICAL CONTRACTOR SHALL KEEP THE PREMISES FREE FROM ACCUMULATION OF WASTE MATERIAL AND RUBBISH DAILY AND AT THE COMPLETION OF THE WORK, CONTRACTOR SHALL REMOVE FROM THE PREMISES ALL RUBBISH, IMPLEMENTS, AND SURPLUS MATERIALS AND LEAVE THE BUILDING "BROOM CLEAN".
- THE ELECTRICAL CONTRACTOR SHALL PROVIDE A WRITTEN WARRANTY STATING THAT ALL MATERIALS AND WORKMANSHIP ARE FREE FROM DEFECTS FOR A PERIOD OF 12 MONTHS FROM DATE OF FINAL ACCEPTANCE.
- MATERIALS:
 - WIRE AND CABLE SHALL BE COPPER WITH THIN/THIN INSULATION AND BE SIZED AS PER 2008 NEC.
 - ALL WIRING SHALL BE CONCEALED WHERE POSSIBLE. WHERE APPROVED BY THE DESIGNER, EXPOSED WIRING SHALL BE RUN PARALLEL AND PERPENDICULAR TO THE BUILDING CONSTRUCTION.
 - DISCONNECT SWITCHES SHALL BE SQUARE-D GENERAL DUTY FUSIBLE WITH CLASS "R" FUSE CLIPS OR EQUAL.
 - FUSES SHALL BE TIME-DELAY DUAL ELEMENT TYPE AND SHALL BE SIZED AS REQUIRED, AND QUANTITY.
 - ALL SWITCHES AND RECEPTACLES SHALL BE SPECIFICATION GRADE AND COLOR AS CHOSEN BY OWNER.
- THE ELECTRICAL CONTRACTOR MUST INSPECT JOB SITE PRIOR TO BIDDING JOB AND WILL INCLUDE COMPLETE RESPONSIBILITY FOR ALL LABOR AND MATERIALS AS SPECIFIED ON PLANS.
- ELECTRICAL CONTRACTOR SHALL VERIFY THE AIG BEFORE PURCHASE OF SERVICE ENTRANCE EQUIPMENT.
- ELECTRICAL CONTRACTOR SHALL VERIFY EQUIPMENT CAPACITY BEFORE ROUGH-IN.
- ALL WIRING SHALL BE IN CONDUIT AND BE 12 AWG UNLESS OTHERWISE SPECIFIED. CONDUIT SHALL BE EMT OR RMC.
- CONDUIT IN AND UNDER SLAB SHALL BE SCHEDULE 40 PVC AND SHALL BE BELOW THE FROST LINE.

PRIME PROFESSIONAL FIRM LOGO

Project Title
**COMMONWEALTH OF VIRGINIA
 BURN BUILDING PROP
 PROTOTYPE 2
 CLASS B FUEL**

SUB-CONSULTANT'S LOGO



Department of Fire Programs

NOT FOR CONSTRUCTION
 THESE DRAWINGS ARE OWNED BY THE COMMONWEALTH OF VIRGINIA © 2013

No.	REVISIONS	Date

Sheet Title
GENERAL NOTES
 CITY/COUNTY VIRGINIA
 Drawn By: SJS Approved By: MAM
 Checked By: SMF Date: 04/11/13

Sheet No.
A0.2
 3 of 18

PROFESSIONAL SEAL

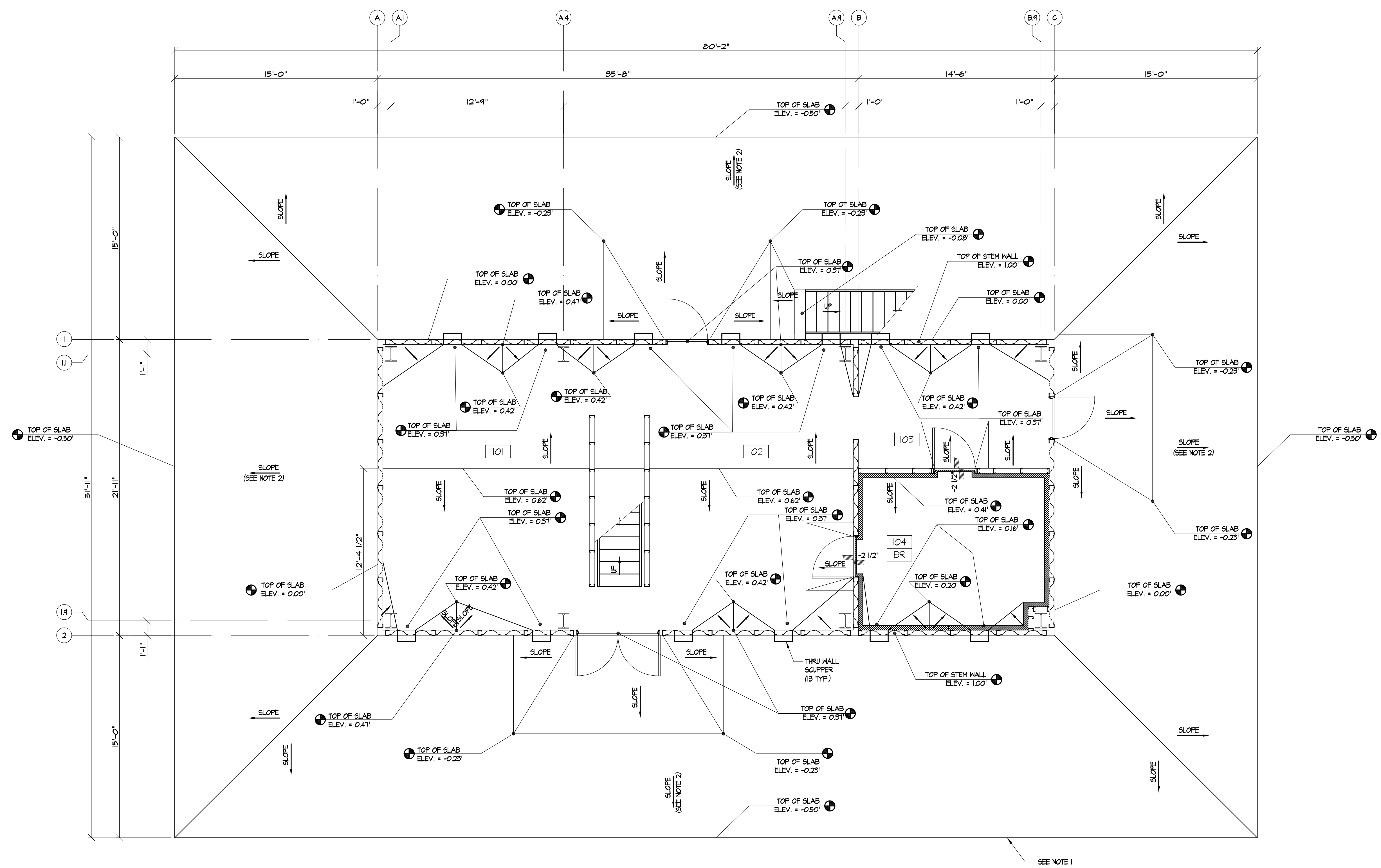

SLAB ELEVATION PLAN

SCALE: 1/4" = 1'-0"

- NOTES:**
- 1 SLAB TURNDOWNS AND JOINTS ARE NOT SHOWN FOR CLARITY SEE SHEET S1.0 FOR ADDITIONAL INFORMATION.
 - 2 PROVIDE MINIMUM SLOPE TO DRAIN OF 1/4" PER FT.
 - 3 COLUMN MAIN FRAMES ARE OPTIONAL - DEPENDING ON METAL BUILDING MANUFACTURER.

PRIME PROFESSIONAL FIRM LOGO

Project Title
**COMMONWEALTH OF VIRGINIA
 BURN BUILDING PROP
 PROTOTYPE 2
 CLASS B FUEL**

SUB-CONSULTANT'S LOGO



**Department
 of
 Fire Programs**

**NOT FOR
 CONSTRUCTION**

THESE DRAWINGS ARE OWNED BY THE COMMONWEALTH OF VIRGINIA © 2013

No.	REVISIONS	Date

Sheet Title
SLAB ELEVATION PLAN

CITY/COUNTY VIRGINIA

Drawn By: SJS Approved By: MAM

Checked By: SMF Date: 04/11/13

PROFESSIONAL SEAL

Sheet No.

A1.0

4 of 18

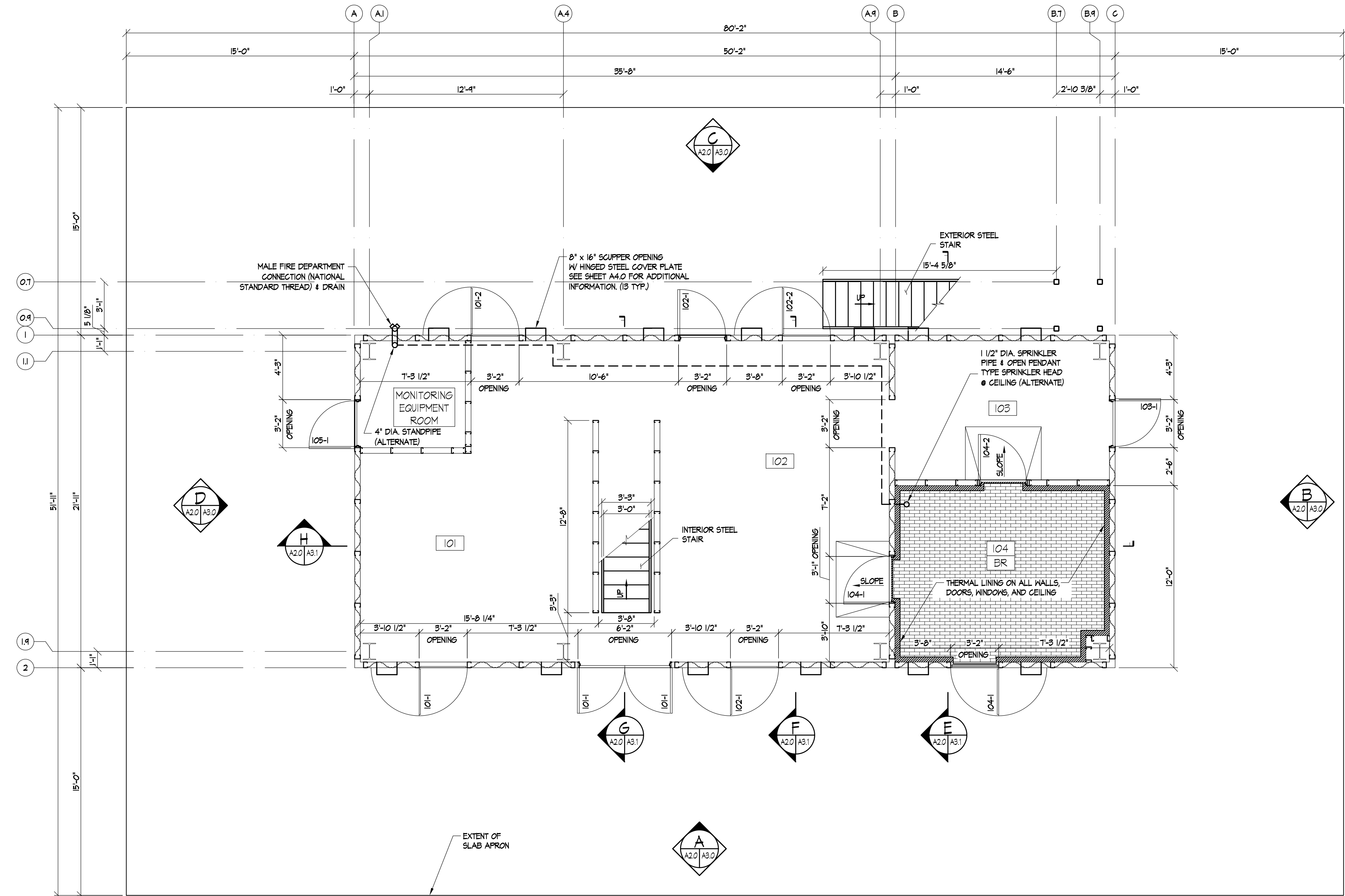

FIRST FLOOR PLAN

SCALE: 1/4" = 1'-0"

NOTES:

- 1 ROOM 104 IS A BURN ROOM. NO BURNING IS ALLOWED IN ROOMS 101, 102, 103, MONITORING EQUIPMENT ROOM, OR ON THE STAIRS OR LANDING.
- 2 DOORS SHALL BE HOT DIPPED GALV. HOLLOW METAL WITH CONTINUOUSLY WELDED SEAMS AND GALV. STEEL ANGLE SUPPORT FRAME. DOORS SHALL HAVE PULLS ON EACH SIDE AS WELL AS A LOCKABLE LATCH THAT IS OPERABLE FROM BOTH SIDES.
- 3 WINDOW SHUTTERS SHALL BE HOT DIPPED GALV. HOLLOW METAL WITH CONTINUOUSLY WELDED SEAMS AND GALV. STEEL ANGLE FRAME SUPPORT. WINDOW SHUTTERS SHALL HAVE WINDOW SHUTTER PULLS ON EACH SIDE AS WELL AS A LOCKABLE LATCH THAT IS OPERABLE FROM BOTH SIDES.
- 4 SEE SLAB ELEVATION PLAN ON SHEET A1.0 FOR ELEVATIONS OF CONCRETE SLAB ON GRADE.

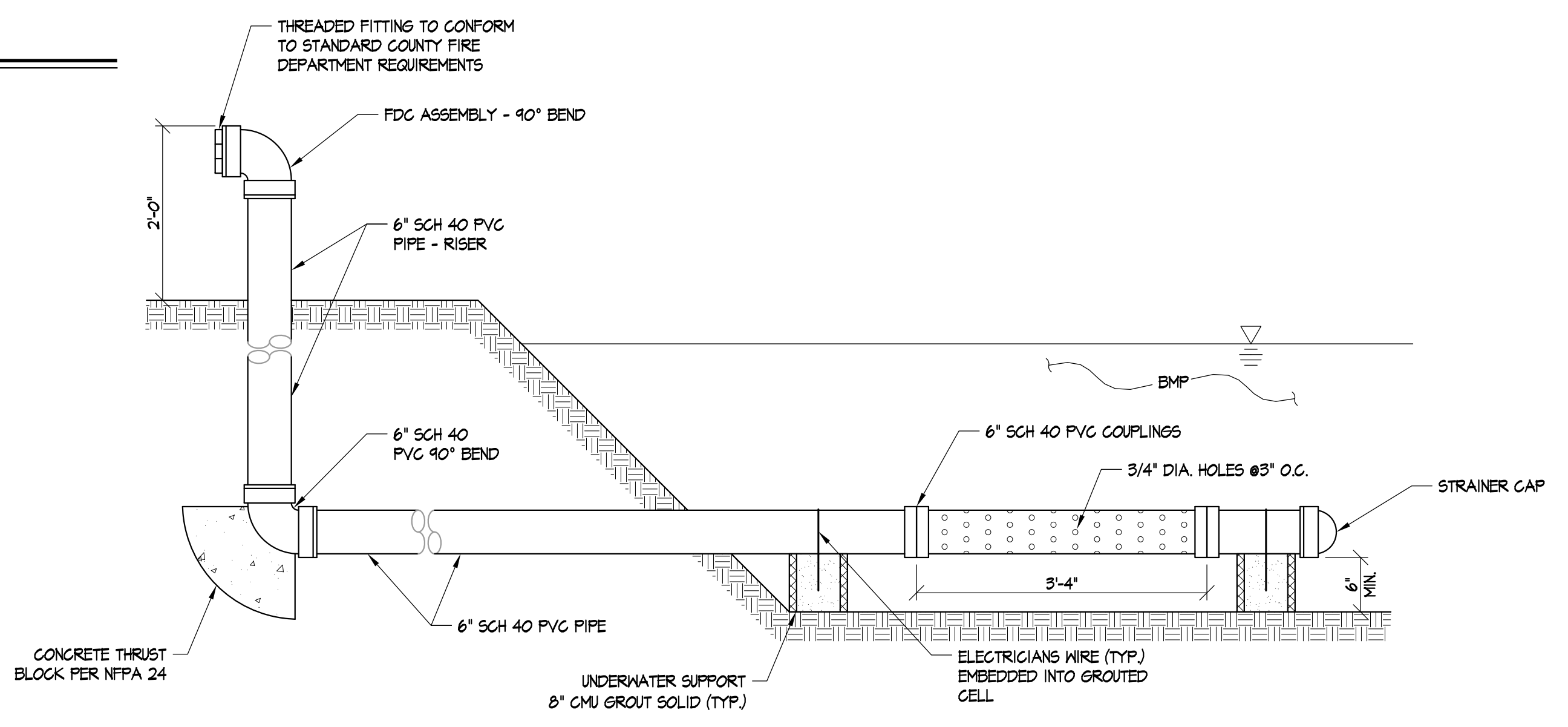

DETAIL

SCALE: NTS

DRY HYDRANT
ALTERNATE

PRIME PROFESSIONAL FIRM LOGO

Project Title
**COMMONWEALTH OF VIRGINIA
BURN BUILDING PROP
PROTOTYPE 2
CLASS B FUEL**

SUB-CONSULTANT'S LOGO



**Department
of
Fire Programs**

**NOT FOR
CONSTRUCTION**

THESE DRAWINGS ARE OWNED BY THE COMMONWEALTH OF VIRGINIA © 2013

No.	REVISIONS	Date

Sheet Title
FIRST FLOOR PLAN

CITY/COUNTY VIRGINIA
 Drawn By: SJS Approved By: MAM
 Checked By: SMF Date: 04/11/13

PROFESSIONAL SEAL

Sheet No.

A2.0

5 of 18

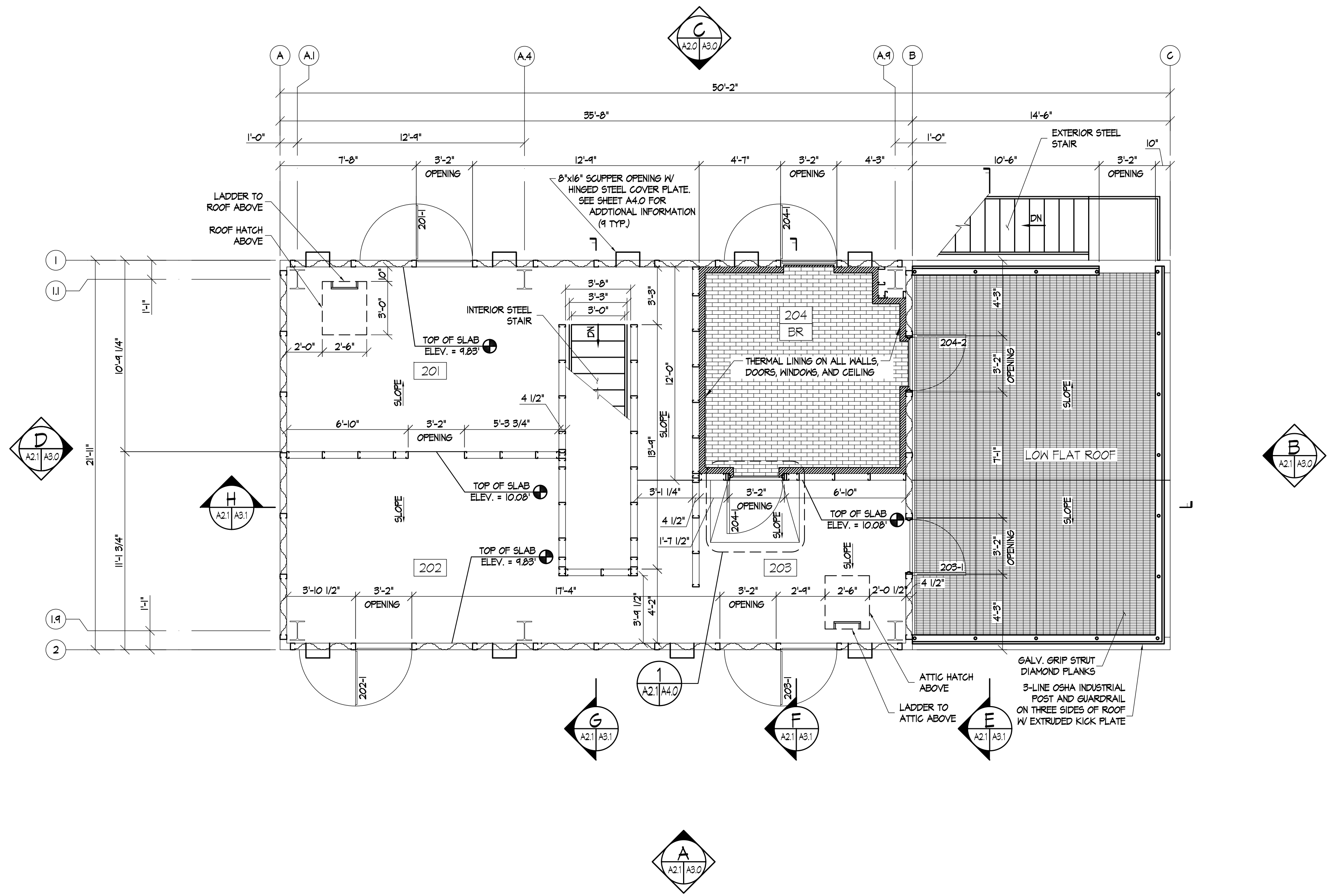

SECOND FLOOR PLAN

SCALE: 1/4" = 1'-0"

NOTES:

- 1 INTERIOR ELEVATED FLOOR SLABS SHALL BE CONCRETE SLAB OVER METAL DECK DESIGNED TO SUPPORT THE SUPERIMPOSED LIVE LOADS INDICATED ON SHEET A0.2.
- 2 EXTERIOR LOW FLAT ROOF SHALL BE WATERTIGHT LIGHT GAGE METAL PANELS COVERED WITH GALV. GRIP STRUT DIAMOND PLANKS.
- 3 ROOM 204 IS A BURN ROOM. NO BURNING IS ALLOWED IN ROOMS 201, 202, 203, ON THE STAIRS, LANDING OR ON THE LOW ROOF.
- 4 REFER TO SHEET A3.0 FOR INDUSTRIAL POST AND GUARDRAIL ELEVATION LOCATIONS.
- 5 DOORS SHALL BE HOT DIPPED GALV. HOLLOW METAL WITH CONTINUOUSLY WELDED SEAMS AND GALV. STEEL ANGLE SUPPORT FRAME. DOORS SHALL HAVE PULLS ON EACH SIDE AS WELL AS A LOCKABLE LATCH THAT IS OPERABLE FROM BOTH SIDES.
- 6 WINDOW SHUTTERS SHALL BE HOT DIPPED GALV. HOLLOW METAL WITH CONTINUOUSLY WELDED SEAMS AND GALV. STEEL ANGLE FRAME SUPPORT. WINDOW SHUTTERS SHALL HAVE WINDOW SHUTTER PULLS ON EACH SIDE AS WELL AS A LOCKABLE LATCH THAT IS OPERABLE FROM BOTH SIDES.

PRIME PROFESSIONAL FIRM LOGO

Project Title
**COMMONWEALTH OF VIRGINIA
 BURN BUILDING PROP
 PROTOTYPE 2
 CLASS B FUEL**

SUB-CONSULTANT'S LOGO



**Department
 of
 Fire Programs**

**NOT FOR
 CONSTRUCTION**

THESE DRAWINGS ARE OWNED BY THE COMMONWEALTH OF VIRGINIA © 2013

No.	REVISIONS	Date

Sheet Title
SECOND FLOOR PLAN

CITY/COUNTY VIRGINIA
 Drawn By: SJS Approved By: MAM
 Checked By: SMF Date: 04/11/13

PROFESSIONAL SEAL

Sheet No.
A2.1
 6 of 18

PRIME PROFESSIONAL FIRM LOGO

Project Title
**COMMONWEALTH OF VIRGINIA
 BURN BUILDING PROP
 PROTOTYPE 2
 CLASS B FUEL**

SUB-CONSULTANT'S LOGO



**Department
 of
 Fire Programs**

**NOT FOR
 CONSTRUCTION**
 THESE DRAWINGS ARE OWNED BY THE
 COMMONWEALTH OF VIRGINIA © 2013

No.	REVISIONS	Date

Sheet Title
**ATTIC FLOOR &
 SLOPED ROOF PLANS**
 CITY/COUNTY VIRGINIA
 Drawn By: SJS Approved By: MAM
 Checked By: SMF Date: 04/11/13

Sheet No.
A2.2
 7 of 18

PROFESSIONAL SEAL

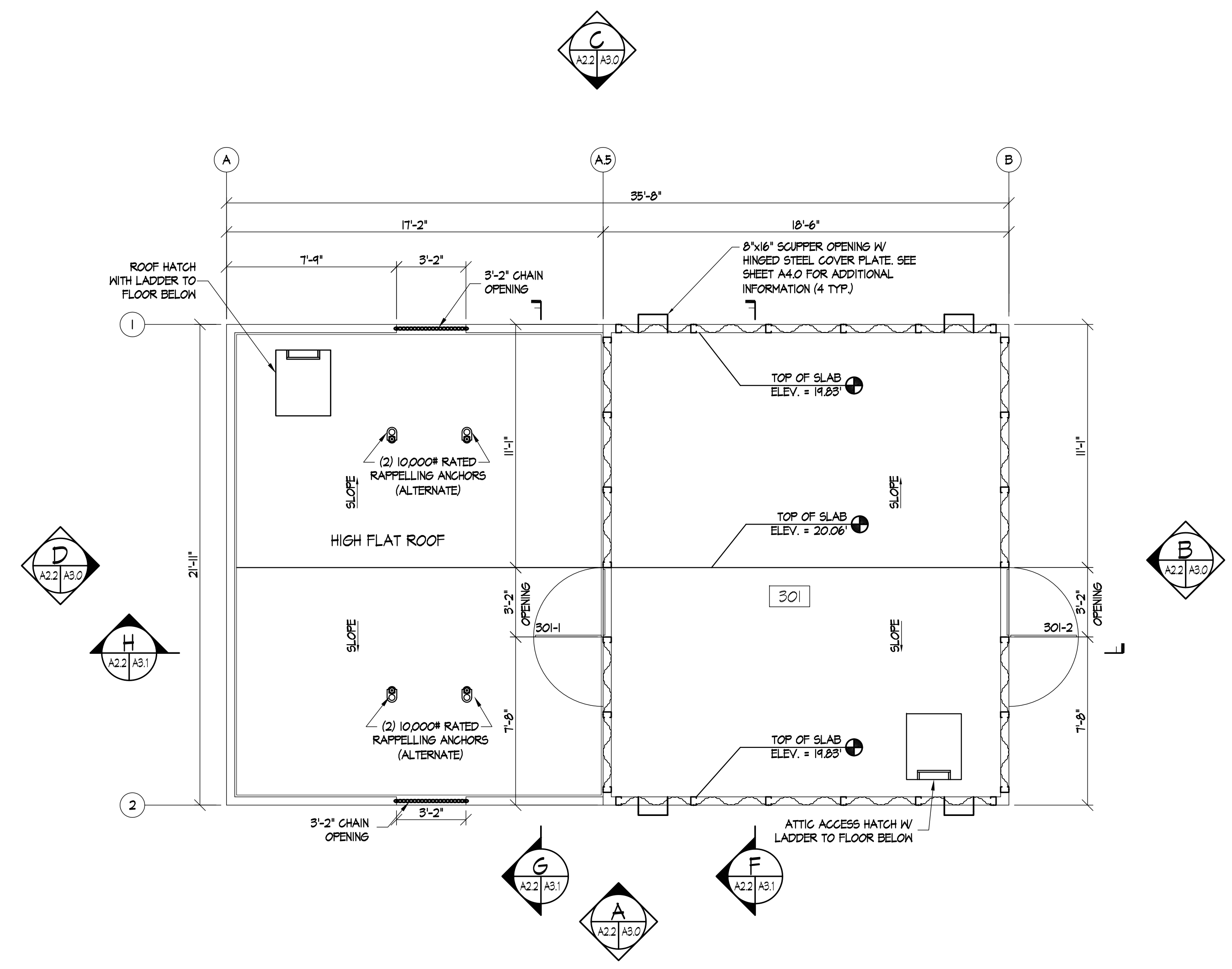

ATTIC FLOOR PLAN

SCALE: 1/4" = 1'-0"

NOTES:

- ELEVATED ATTIC FLOOR AND ROOF SLAB SHALL BE CONCRETE SLAB OVER METAL DECK DESIGNED TO SUPPORT THE SUPERIMPOSED LIVE LOADS INDICATED ON SHEET A0.2.
- NO BURNING IS ALLOWED IN ROOM 301 OR ON THE FLAT ROOF.
- REFER TO SHEET A3.0 FOR INDUSTRIAL POST AND GUARDRAIL ELEVATION LOCATIONS.
- WINDOW SHUTTERS SHALL BE HOT DIPPED GALV. HOLLOW METAL WITH CONTINUOUSLY WELDED SEAMS AND GALV. STEEL ANGLE FRAME SUPPORT. WINDOW SHUTTERS SHALL HAVE WINDOW SHUTTER PULLS ON EACH SIDE AS WELL AS A LOCKABLE LATCH THAT IS OPERABLE FROM BOTH SIDES.

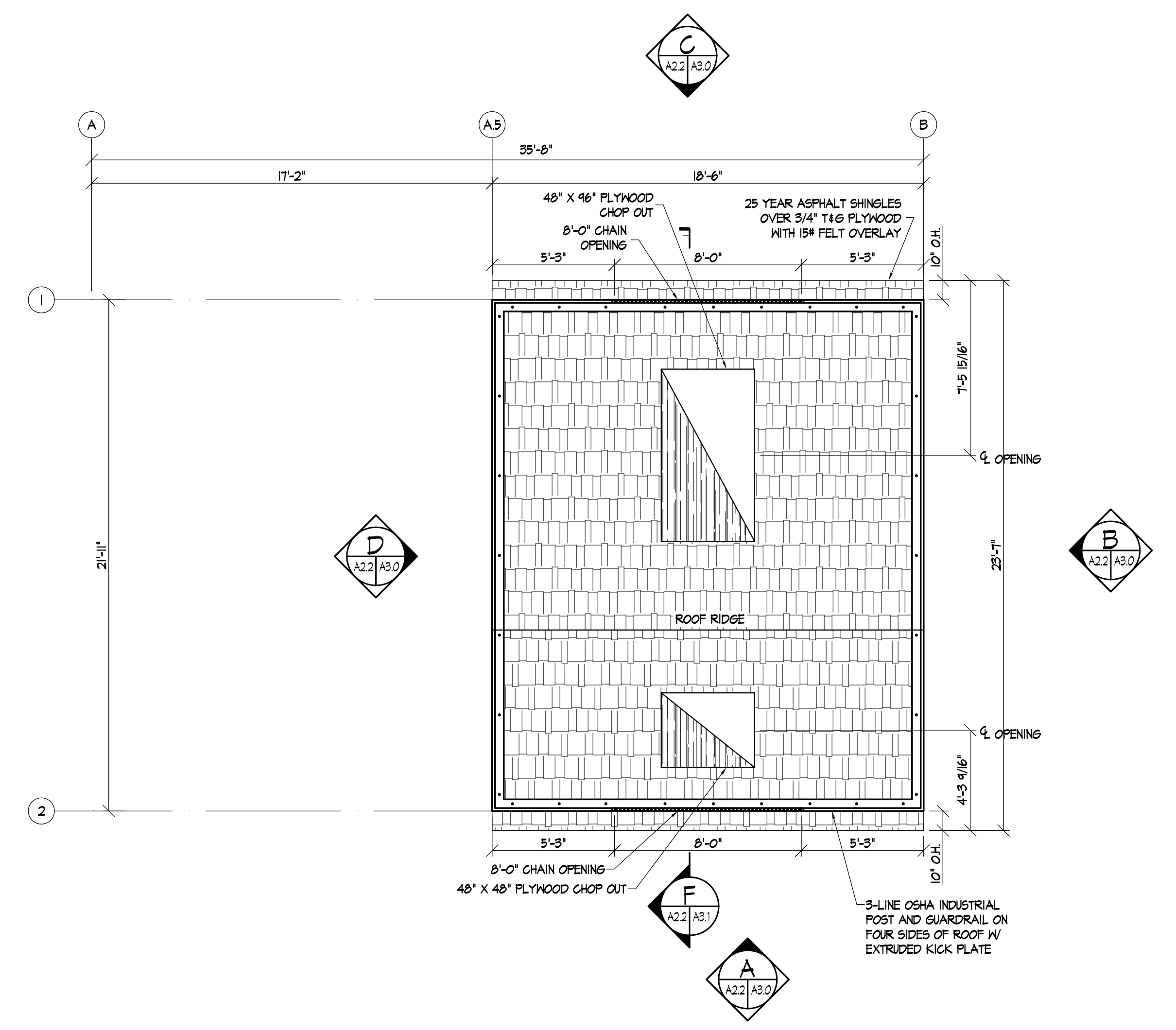

SLOPED ROOF PLAN

SCALE: 1/4" = 1'-0"

NOTES:

- SLOPED ROOF SHALL BE 3/4" TONGUE AND GROOVE PLYWOOD COVERED WITH COMPOSITE ASPHALT SHINGLES AND SHALL BE DESIGNED TO SUPPORT THE SUPERIMPOSED LIVE LOADS INDICATED ON SHEET A0.2.
- REFER TO SHEET A3.0 FOR INDUSTRIAL POST AND GUARDRAIL ELEVATION LOCATIONS.

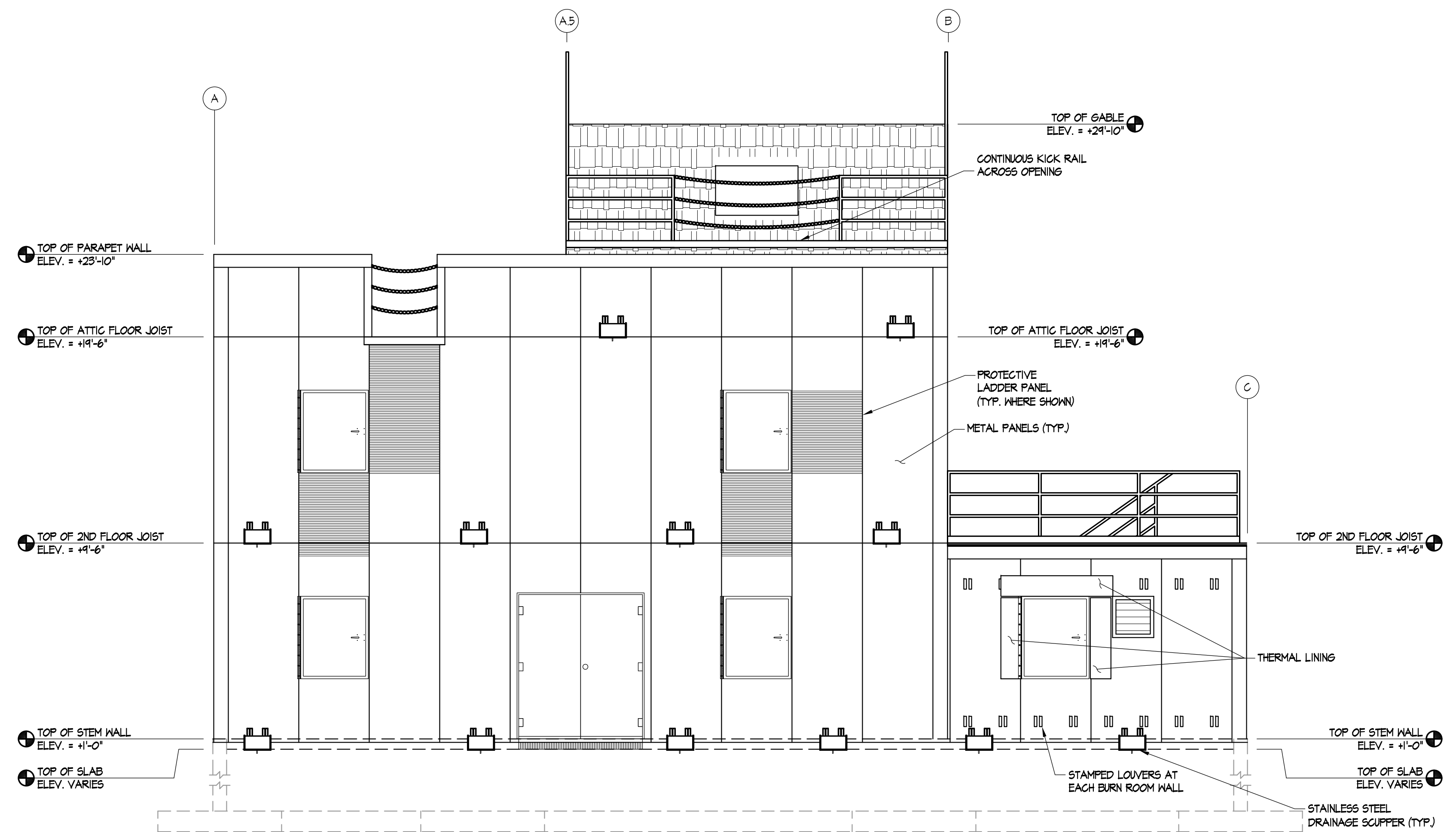

FRONT ELEVATION

SCALE: 1/4" = 1'-0"

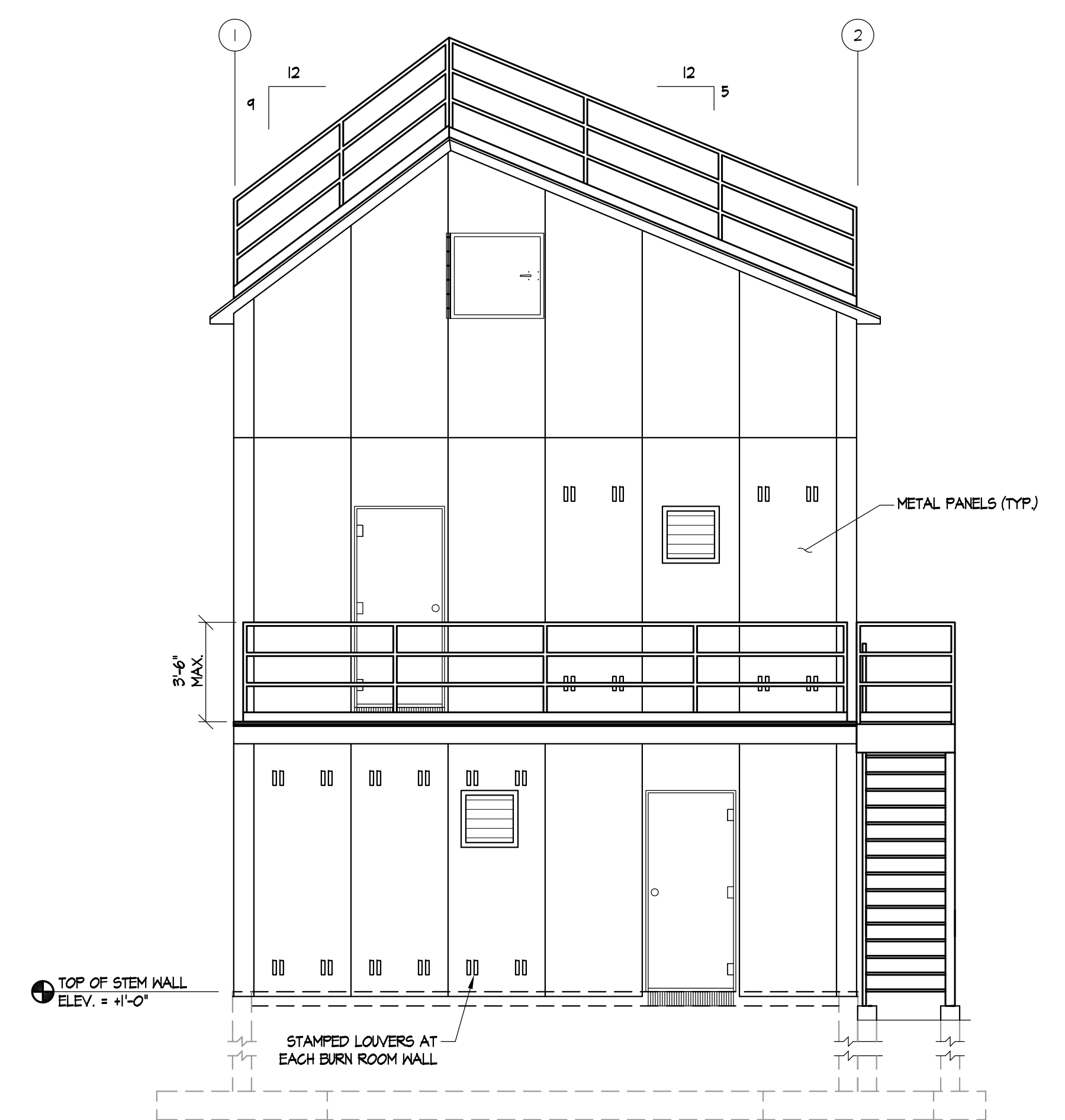
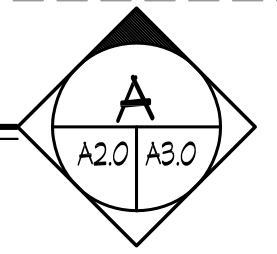

RIGHT ELEVATION

SCALE: 1/4" = 1'-0"

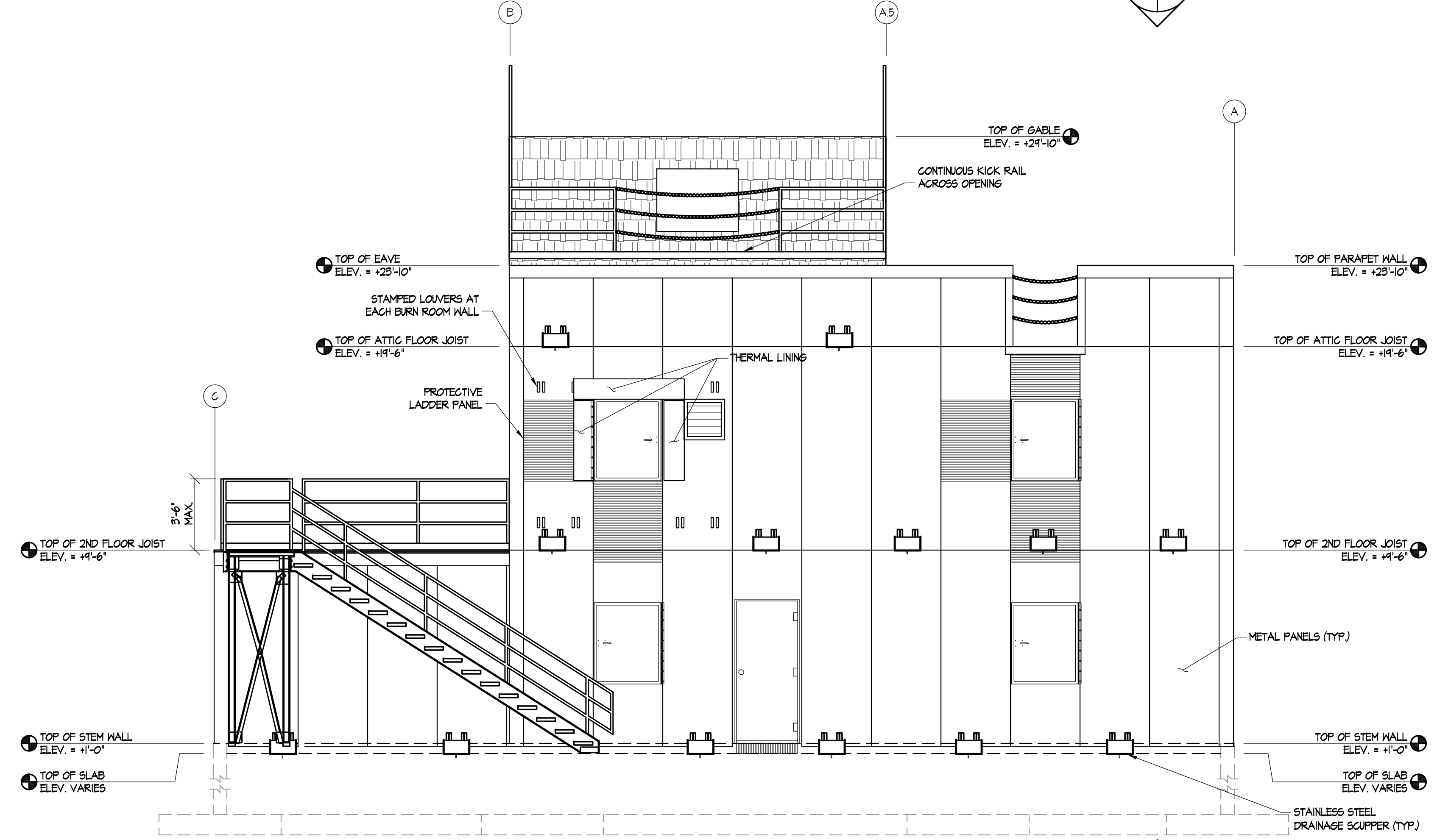
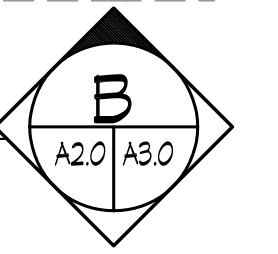

REAR ELEVATION

SCALE: 1/4" = 1'-0"

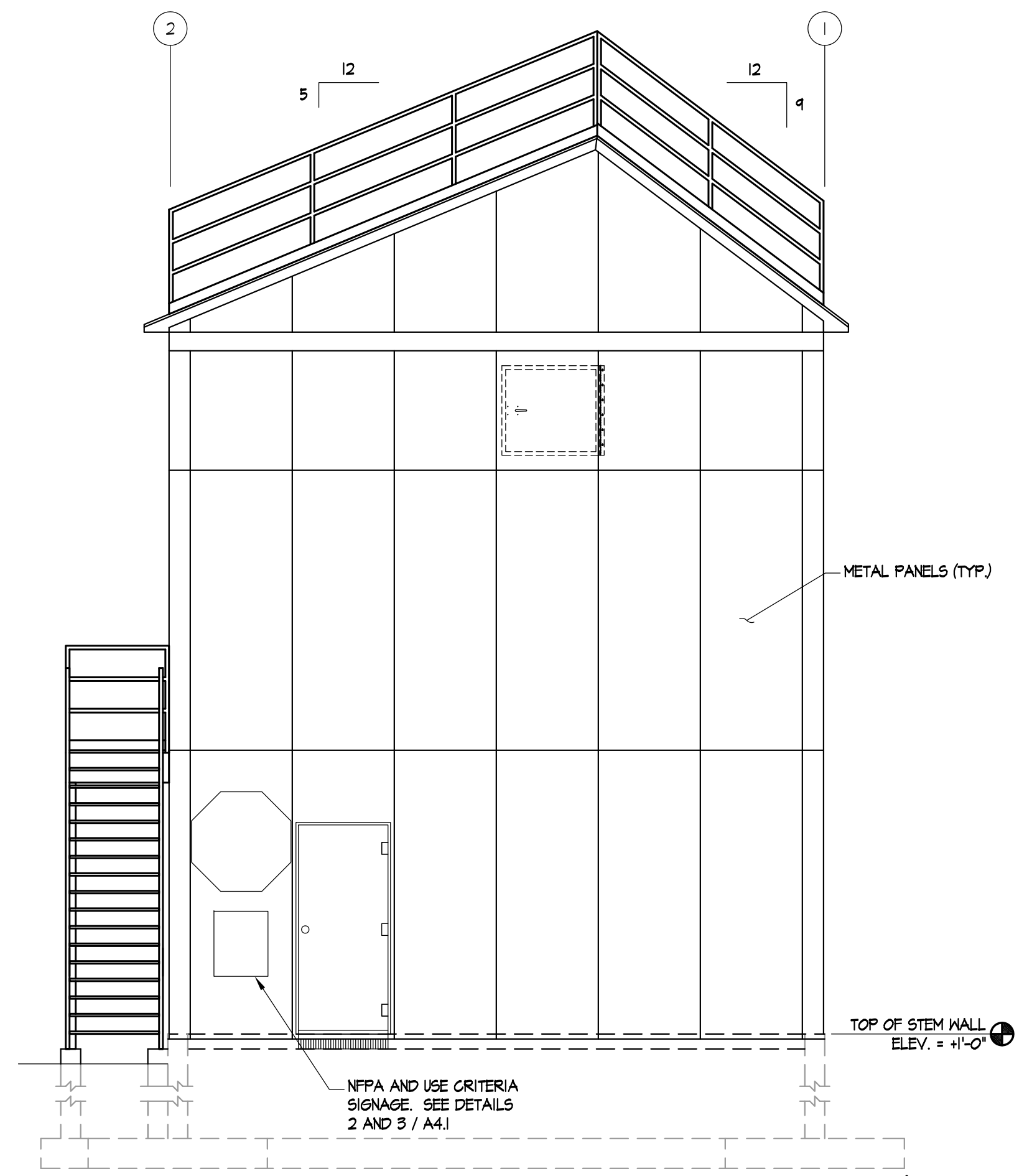
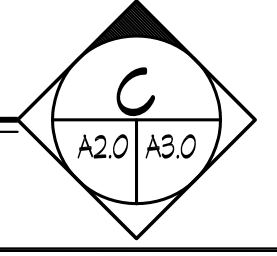

LEFT ELEVATION

SCALE: 1/4" = 1'-0"

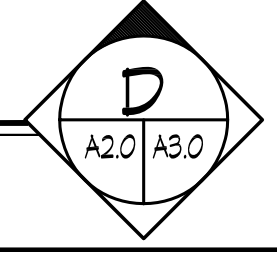

PRIME PROFESSIONAL FIRM LOGO

Project Title
**COMMONWEALTH OF VIRGINIA
 BURN BUILDING PROP
 PROTOTYPE 2
 CLASS B FUEL**

SUB-CONSULTANT'S LOGO



**Department
 of
 Fire Programs**

**NOT FOR
 CONSTRUCTION**

THESE DRAWINGS ARE OWNED BY THE COMMONWEALTH OF VIRGINIA © 2013

No.	REVISIONS	Date

Sheet Title
BUILDING ELEVATIONS

CITY/COUNTY VIRGINIA
 Drawn By: SJS Approved By: MAM
 Checked By: SMF Date: 04/11/13

PROFESSIONAL SEAL

Sheet No.
A3.0
 8 of 18

PRIME PROFESSIONAL FIRM LOGO

Project Title
**COMMONWEALTH OF VIRGINIA
 BURN BUILDING PROP
 PROTOTYPE 2
 CLASS B FUEL**

SUB-CONSULTANT'S LOGO



**Department
 of
 Fire Programs**

**NOT FOR
 CONSTRUCTION**
 THESE DRAWINGS ARE OWNED BY THE
 COMMONWEALTH OF VIRGINIA © 2013

No.	REVISIONS	Date

Sheet Title
BUILDING SECTIONS
 CITY/COUNTY VIRGINIA
 Drawn By: SJS Approved By: MAM
 Checked By: SMF Date: 04/11/13

Sheet No.
A3.1
 9 of 18

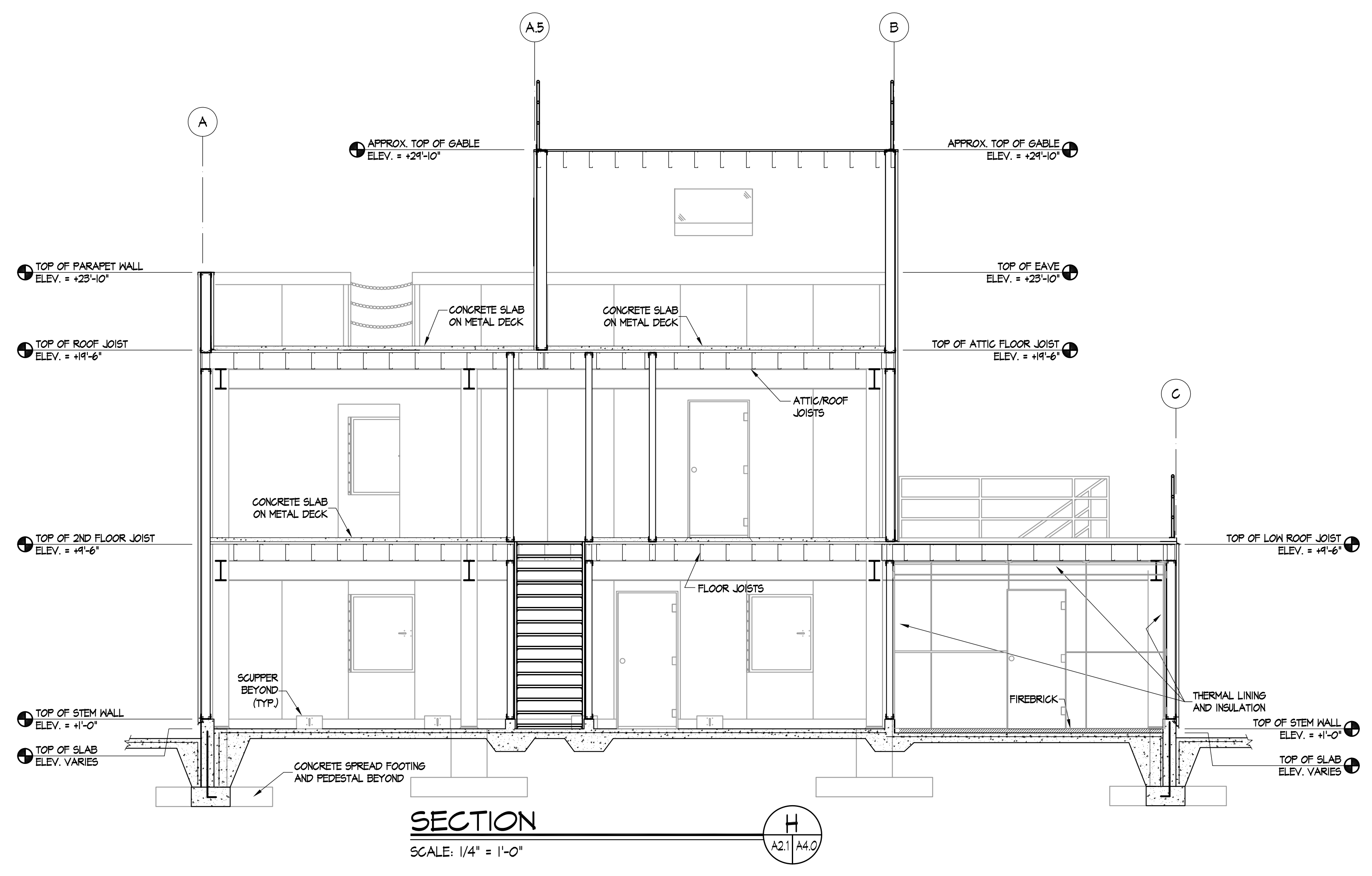
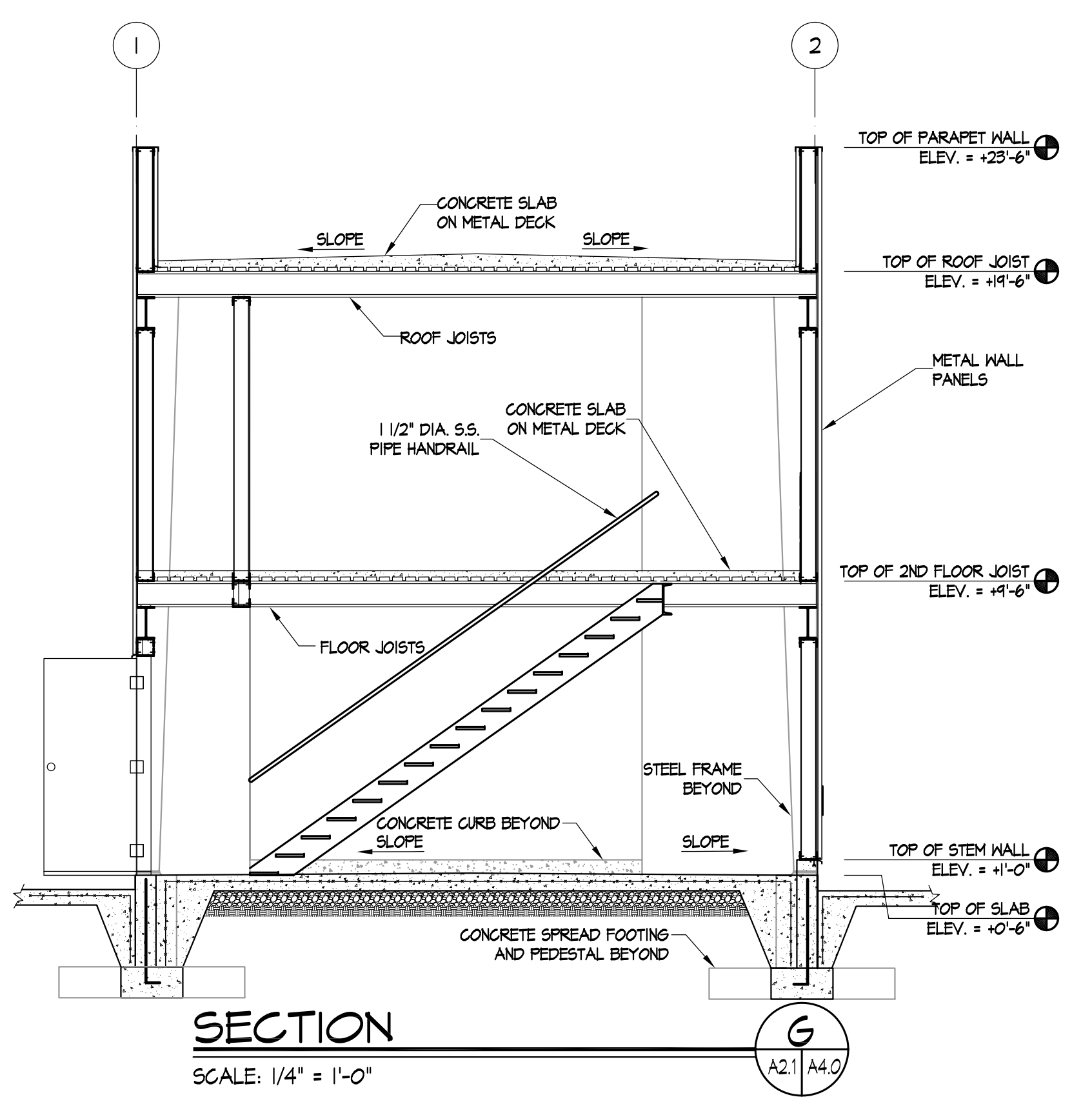
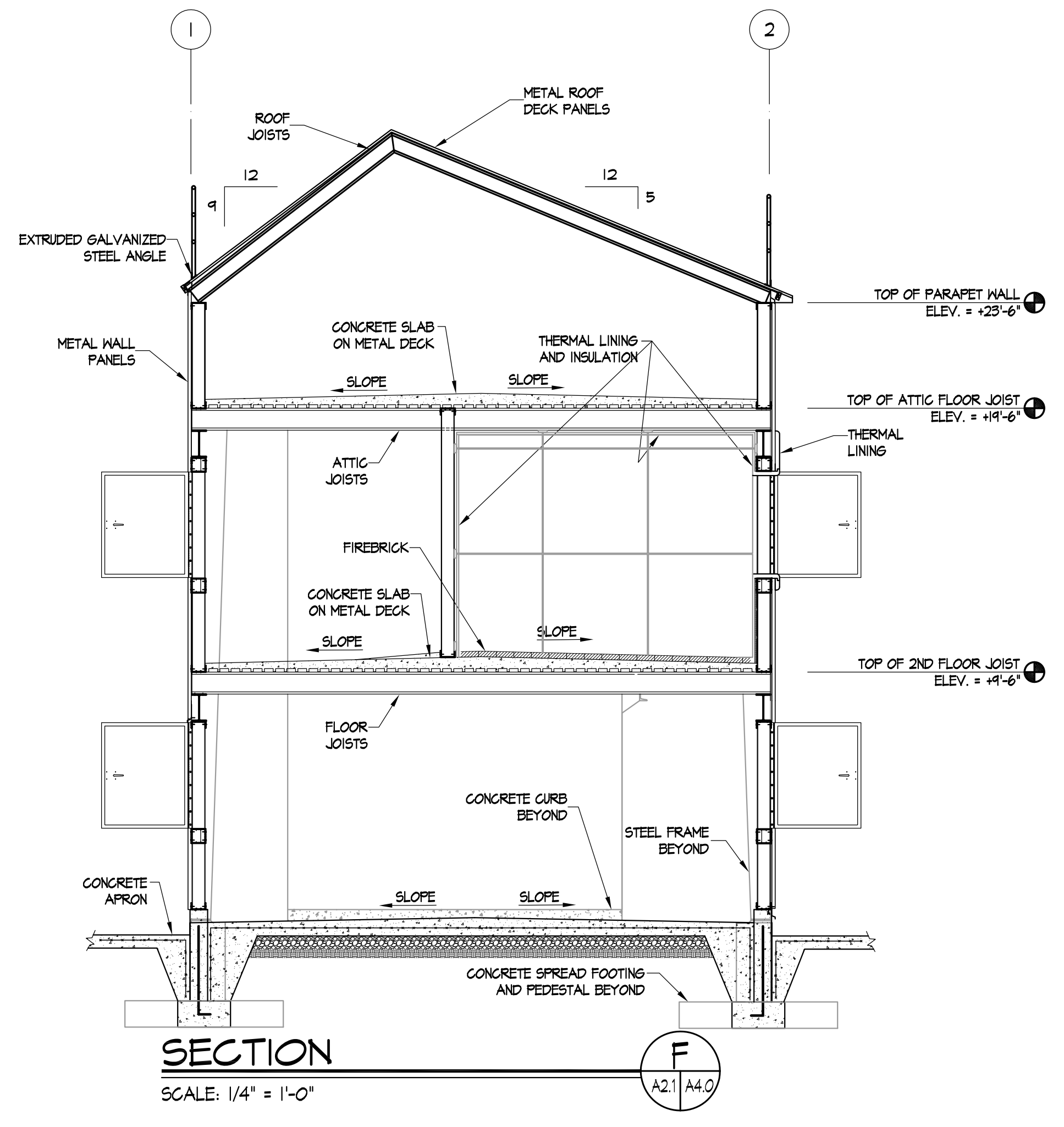
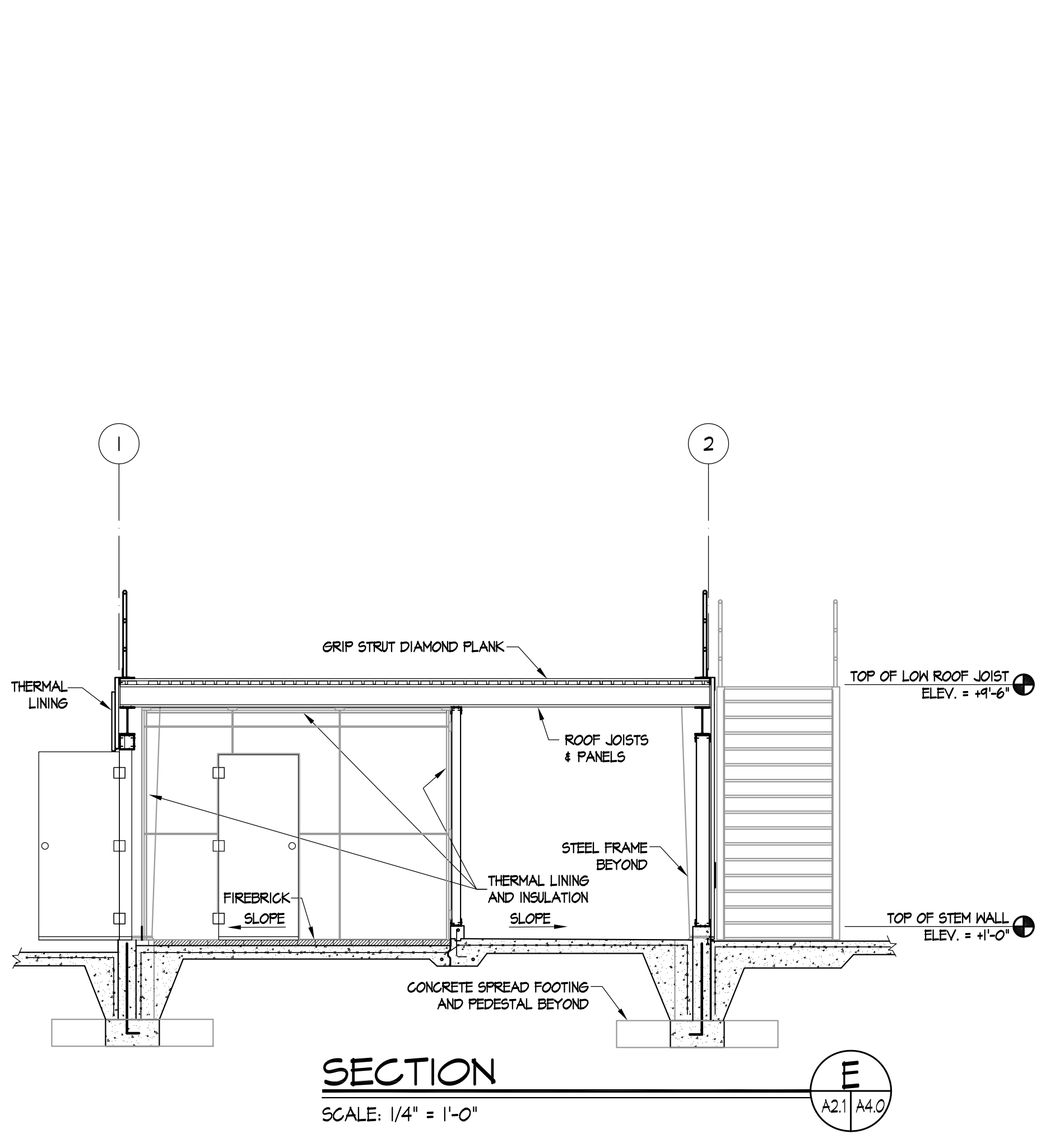

PRIME PROFESSIONAL FIRM LOGO

Project Title
**COMMONWEALTH OF VIRGINIA
 BURN BUILDING PROP
 PROTOTYPE 2
 CLASS B FUEL**

SUB-CONSULTANT'S LOGO



**Department
 of
 Fire Programs**

**NOT FOR
 CONSTRUCTION**
 THESE DRAWINGS ARE OWNED BY THE
 COMMONWEALTH OF VIRGINIA © 2013

No.	REVISIONS	Date

Sheet Title
**SCUPPER, RAMP, &
 THERMAL LINING DETAILS**
 CITY/COUNTY VIRGINIA
 Drawn By: SJS Approved By: MAM
 Checked By: SMF Date: 04/11/13

Sheet No.
A4.0
 10 of 18

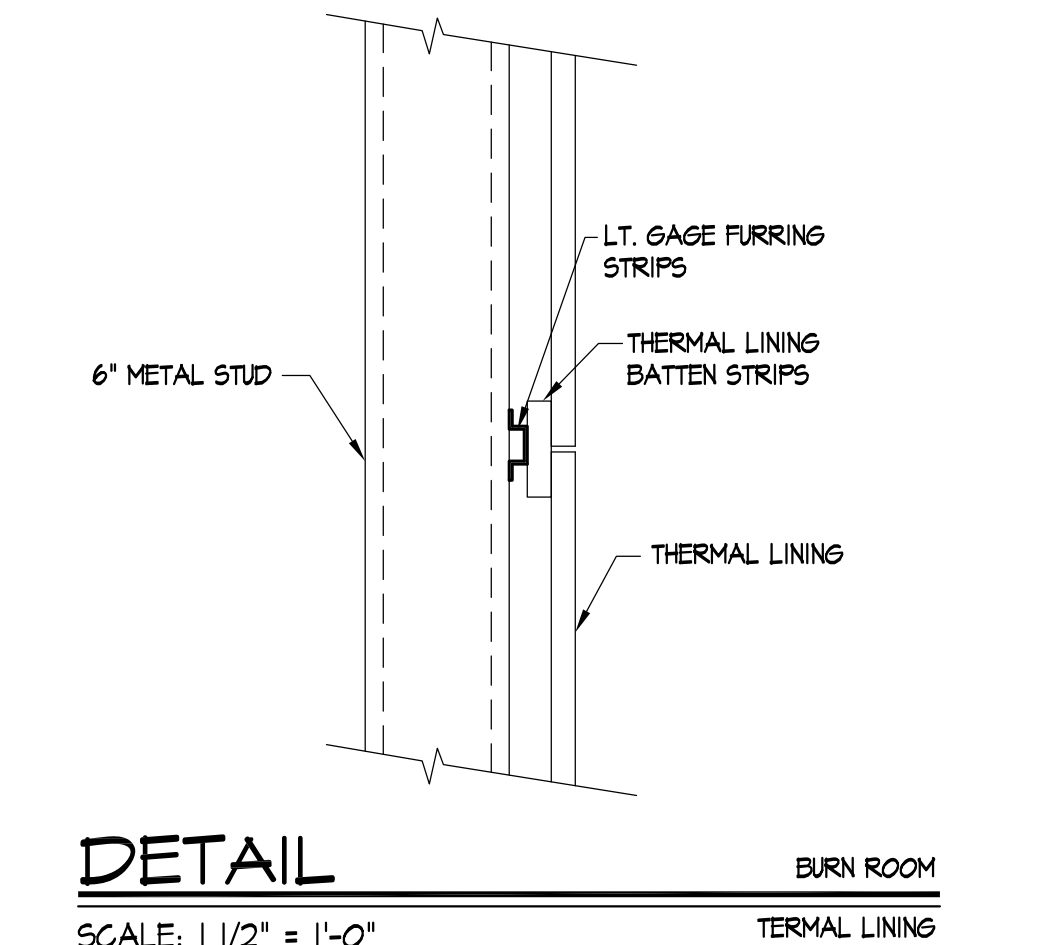
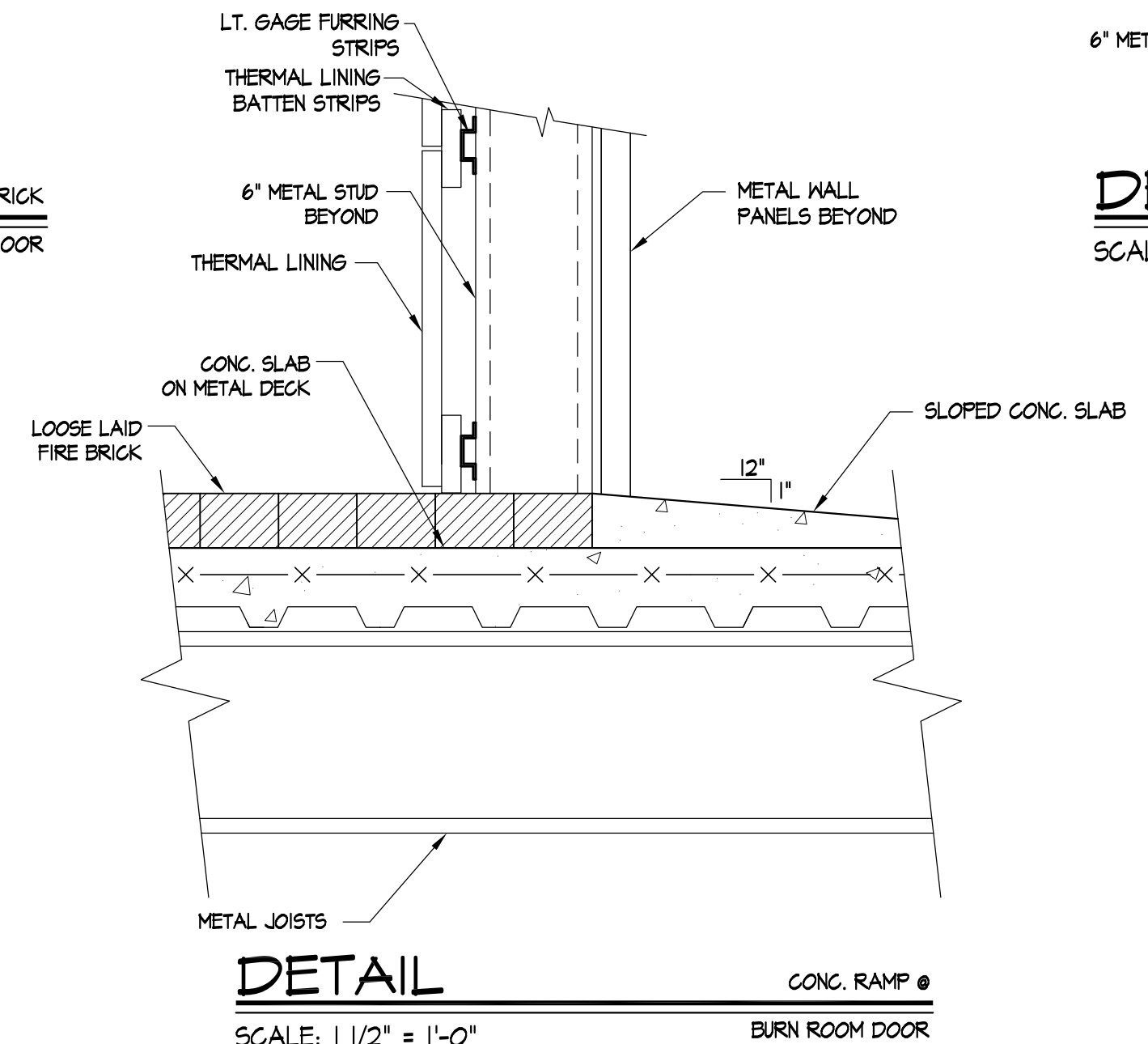
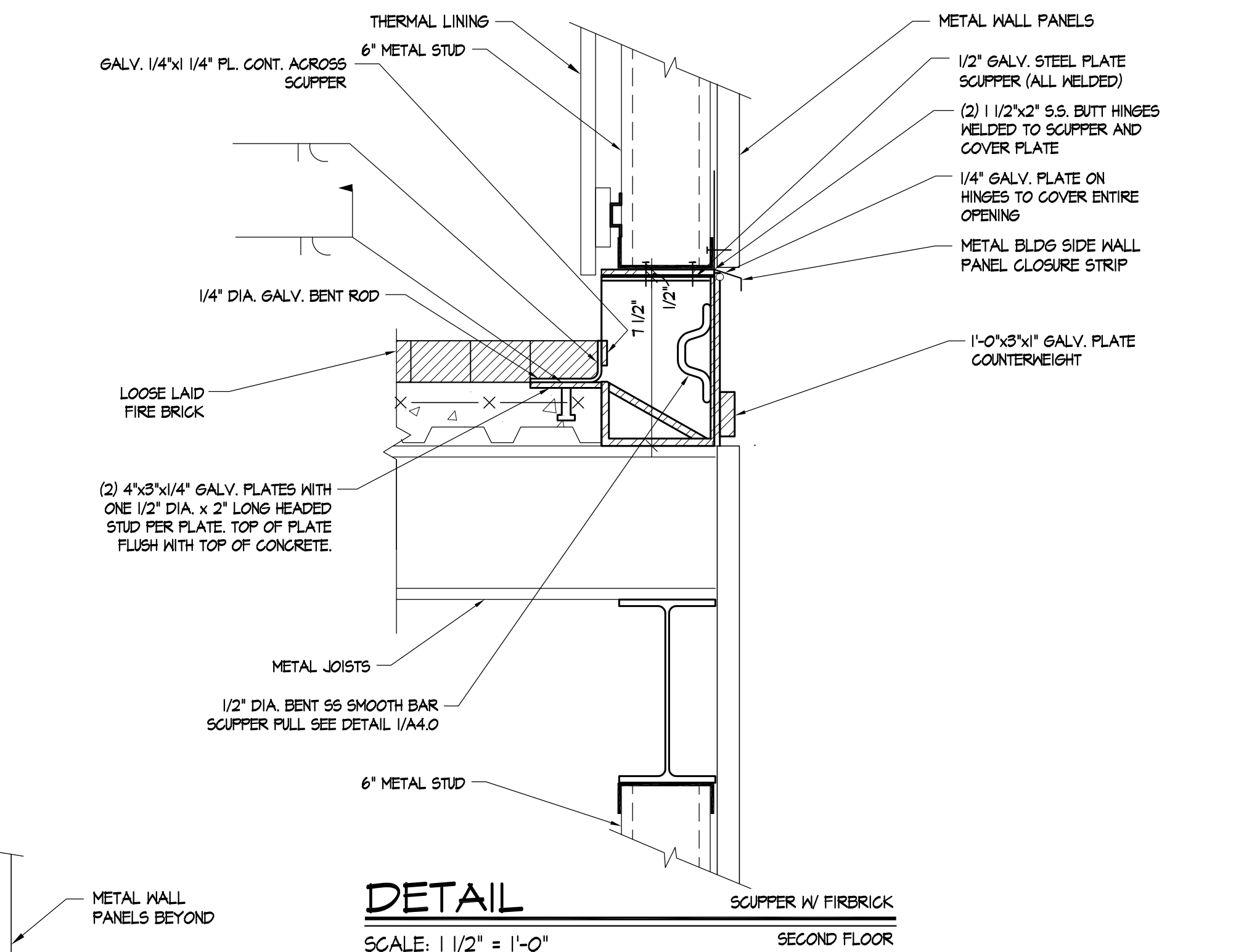
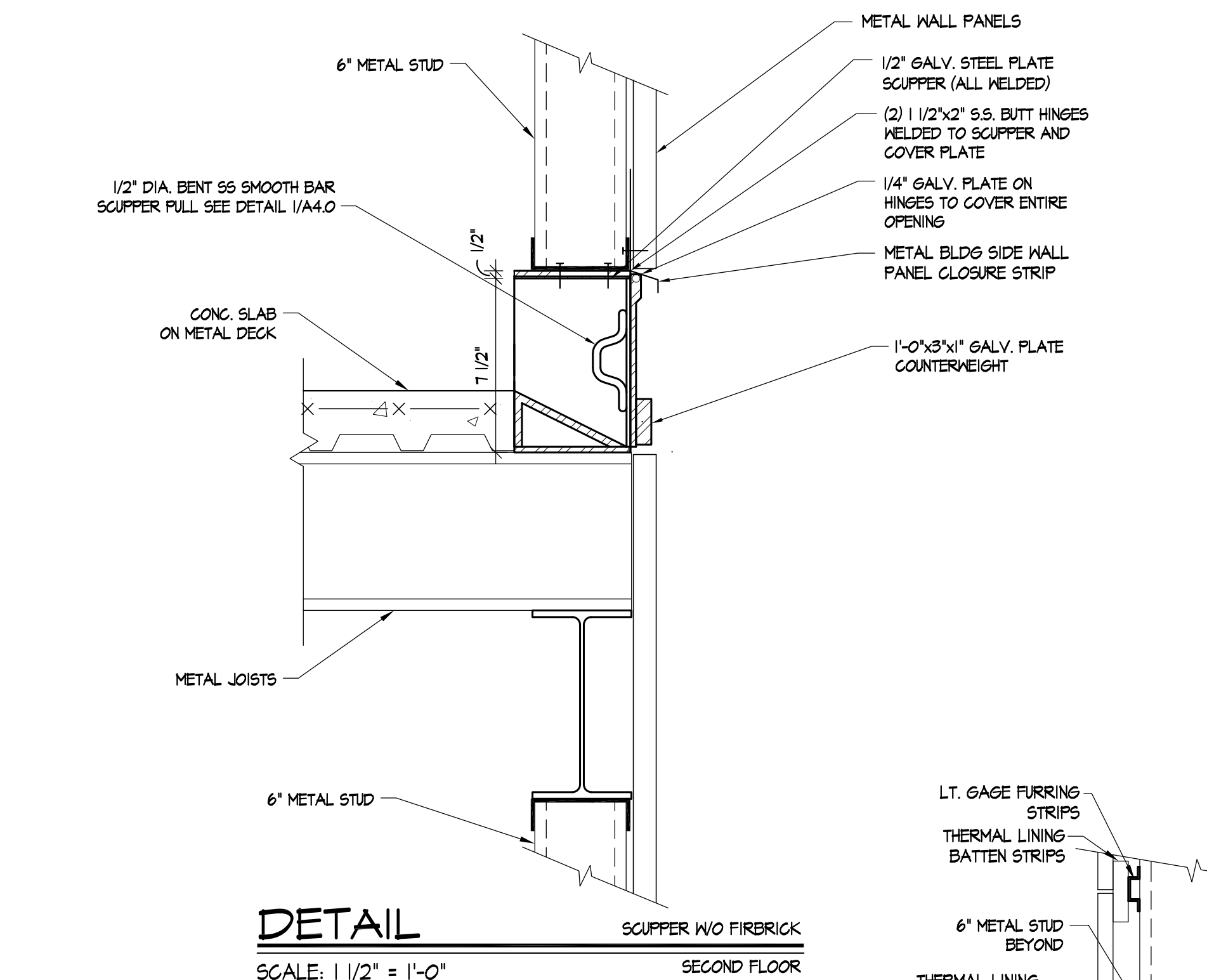
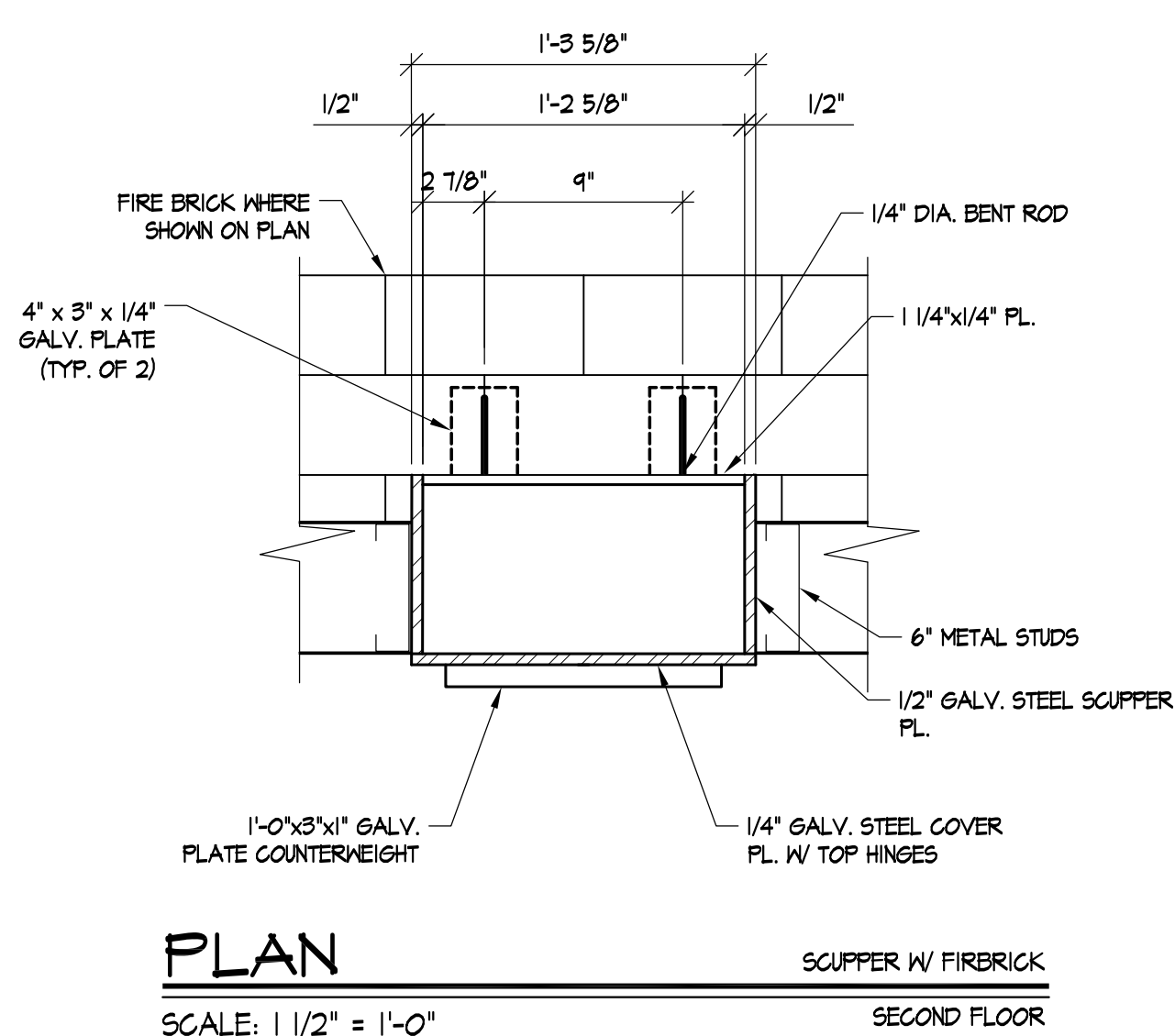
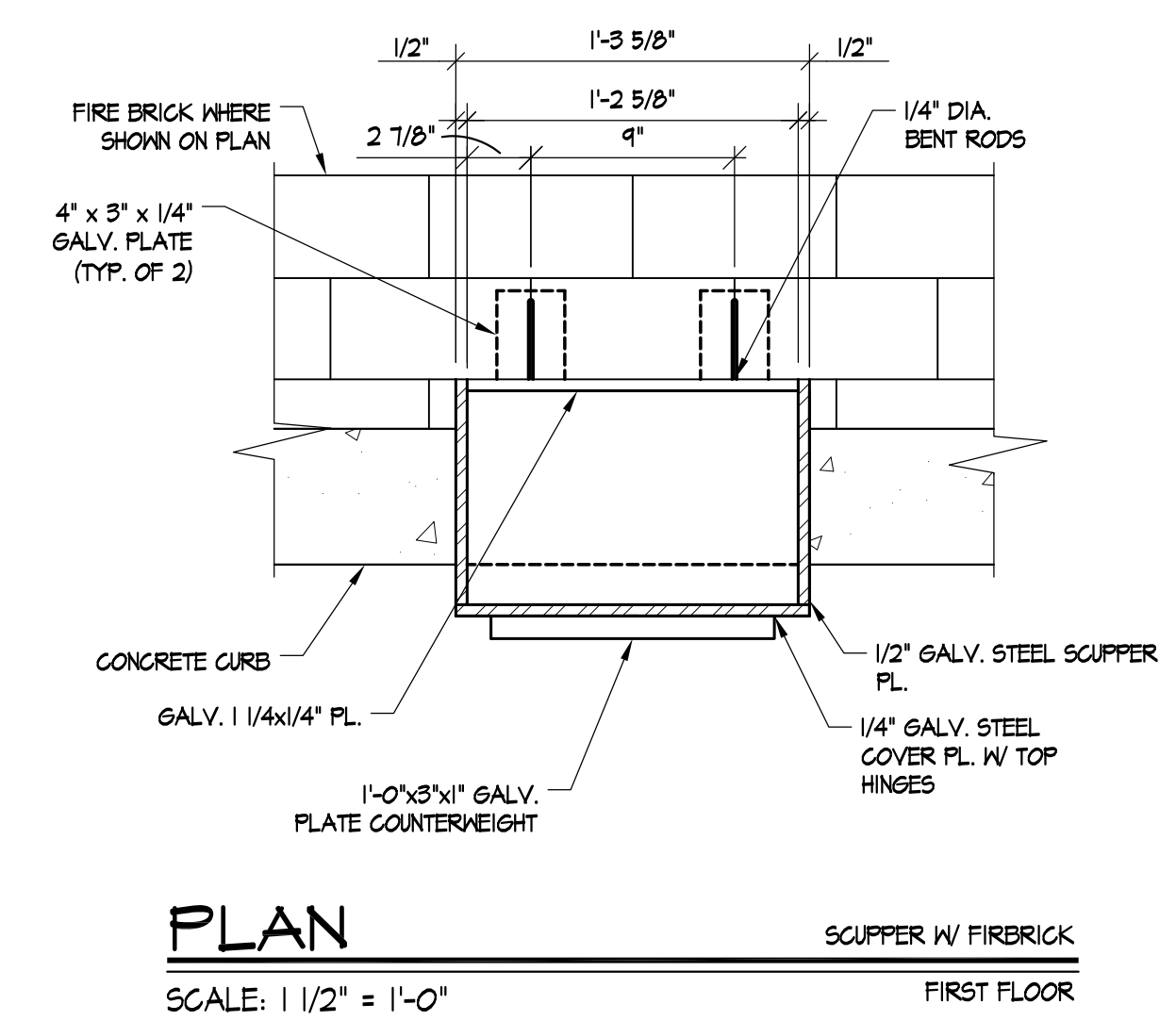
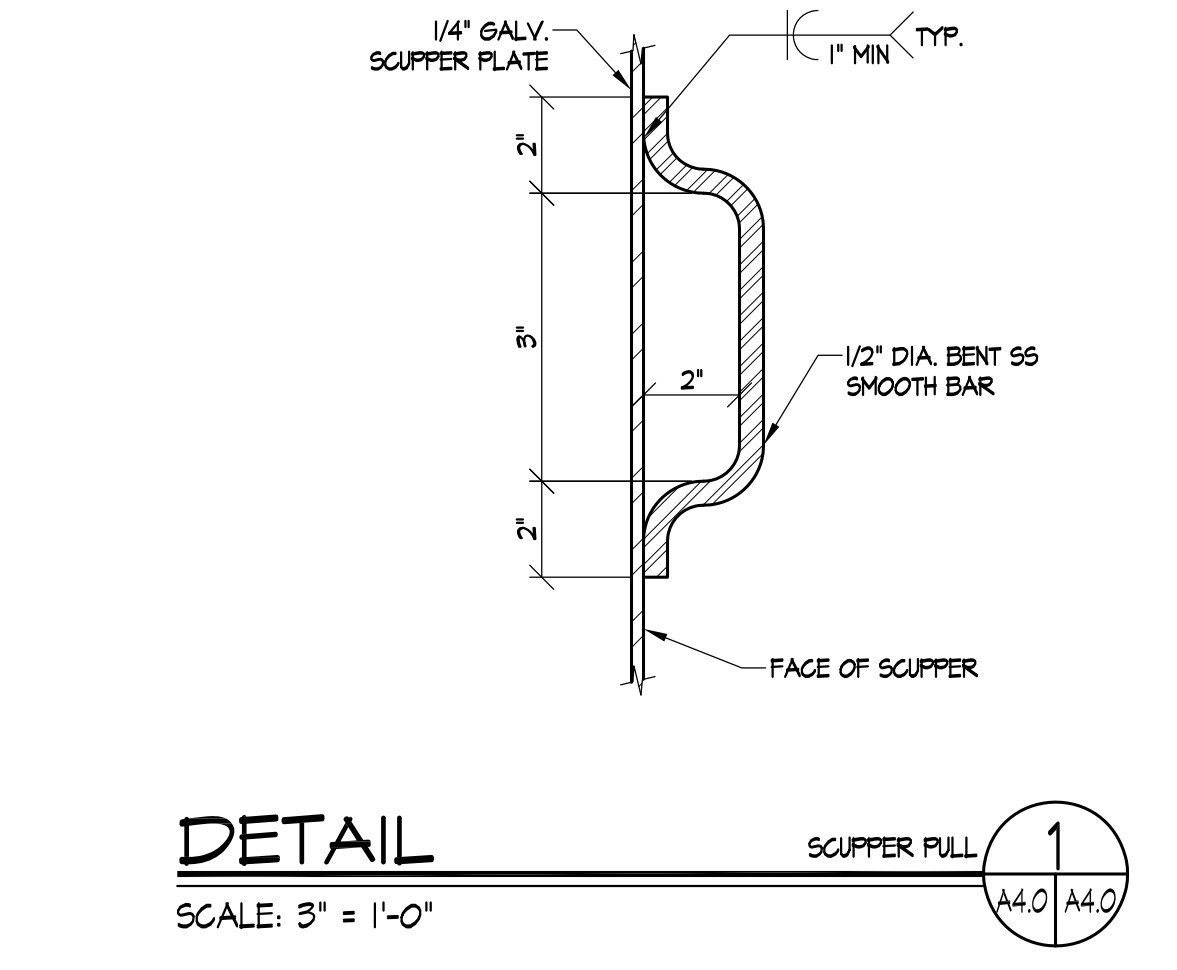
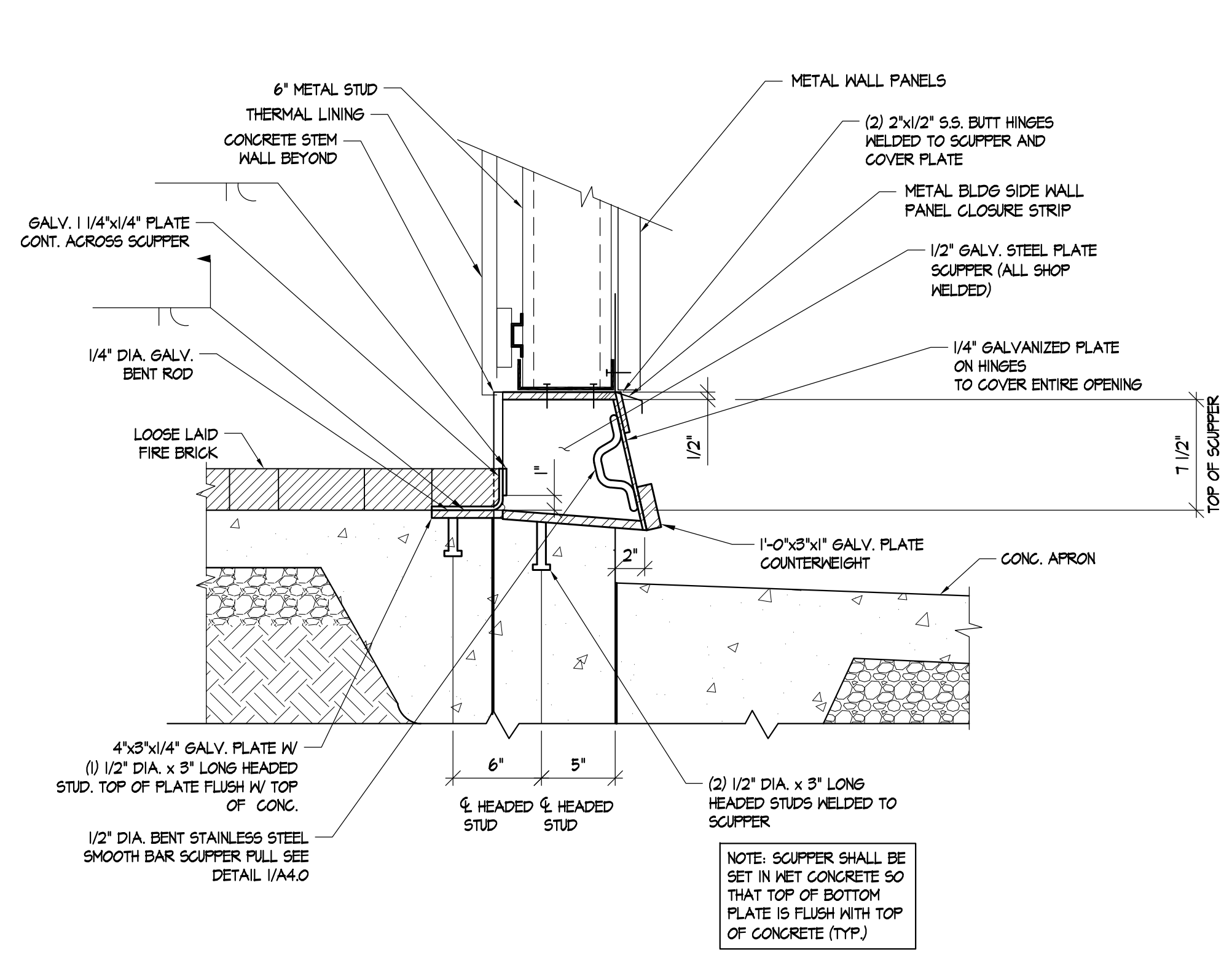
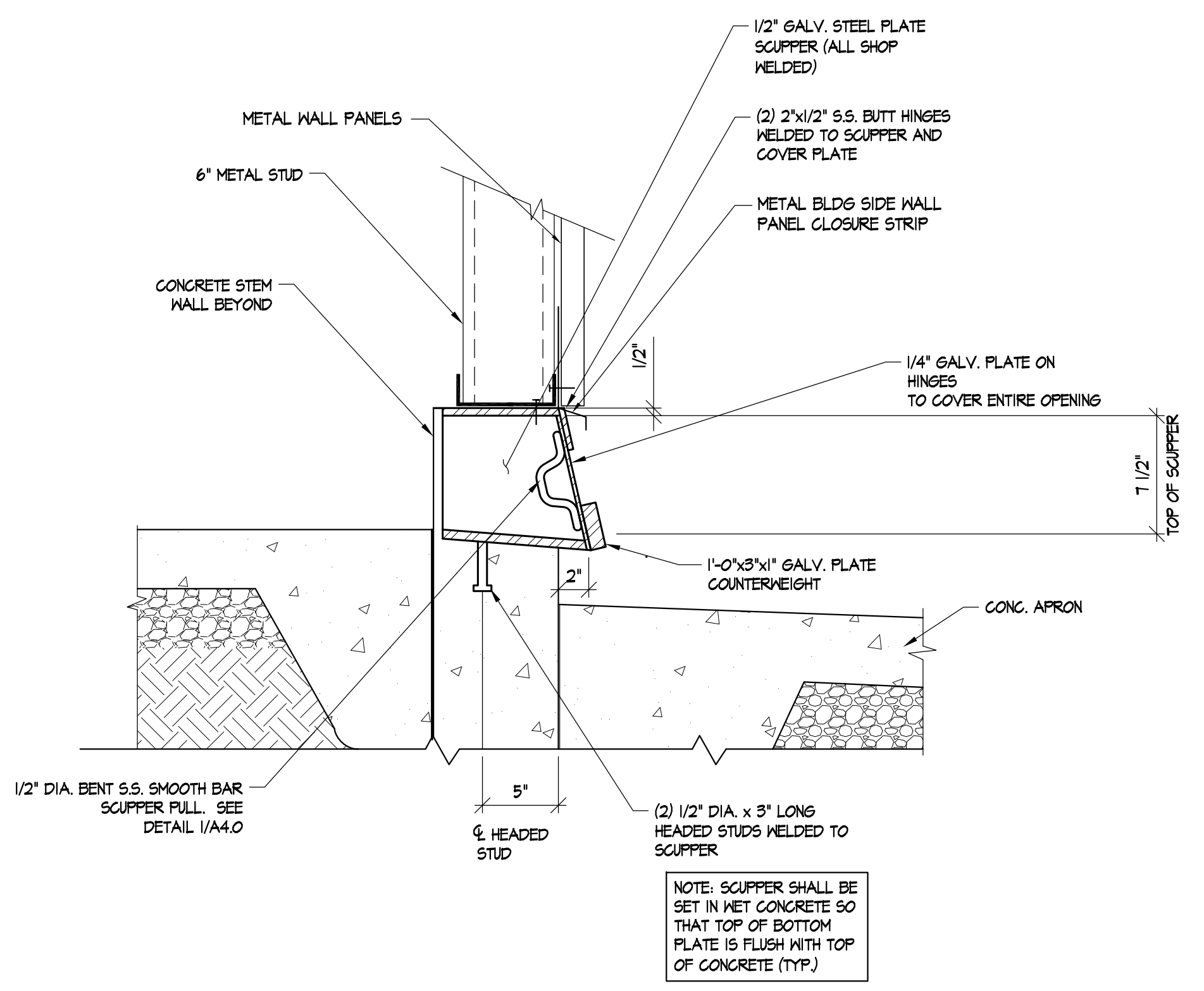

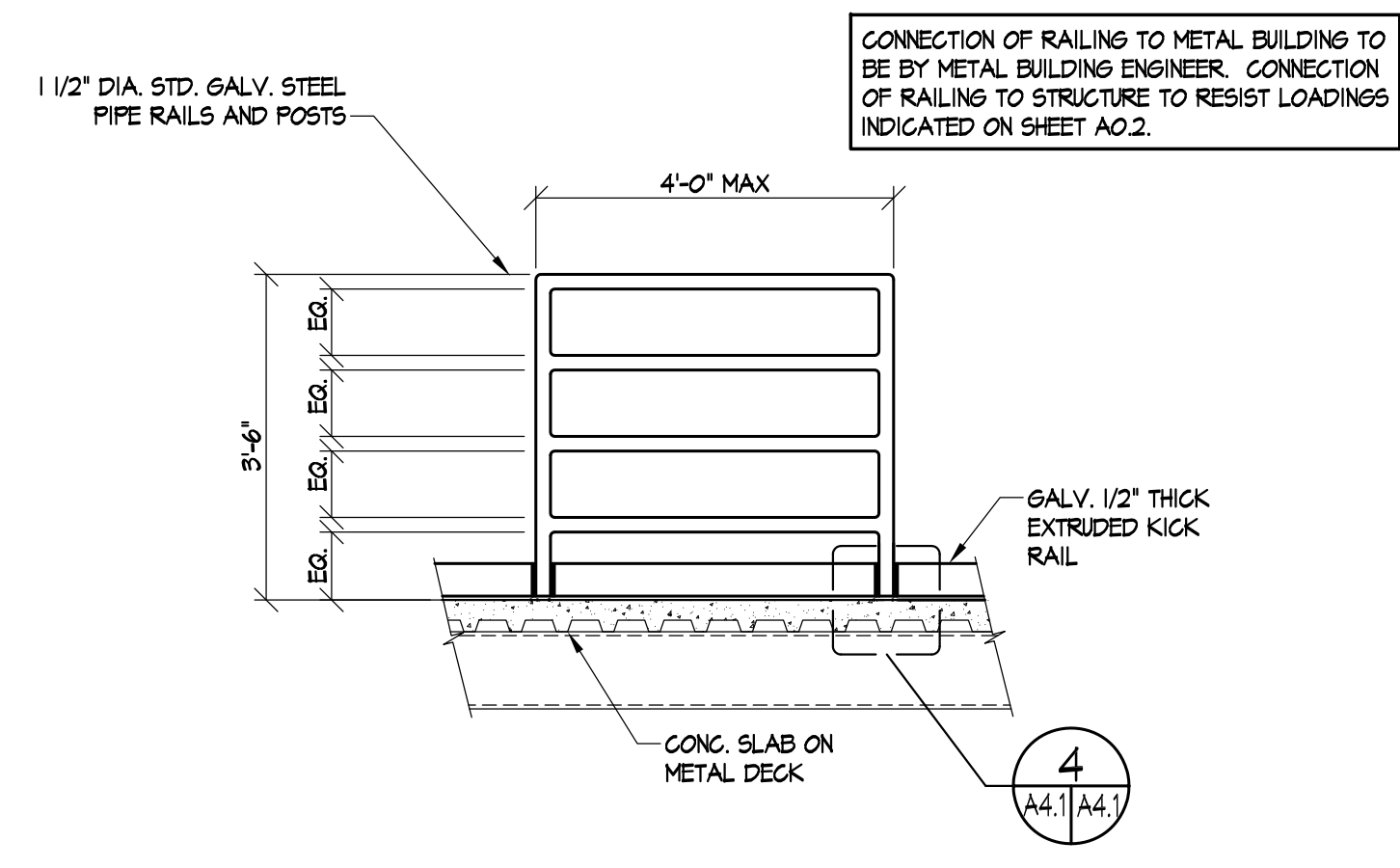

DETAIL REMOVABLE GUARDRAIL
SCALE: 1/2" = 1'-0"

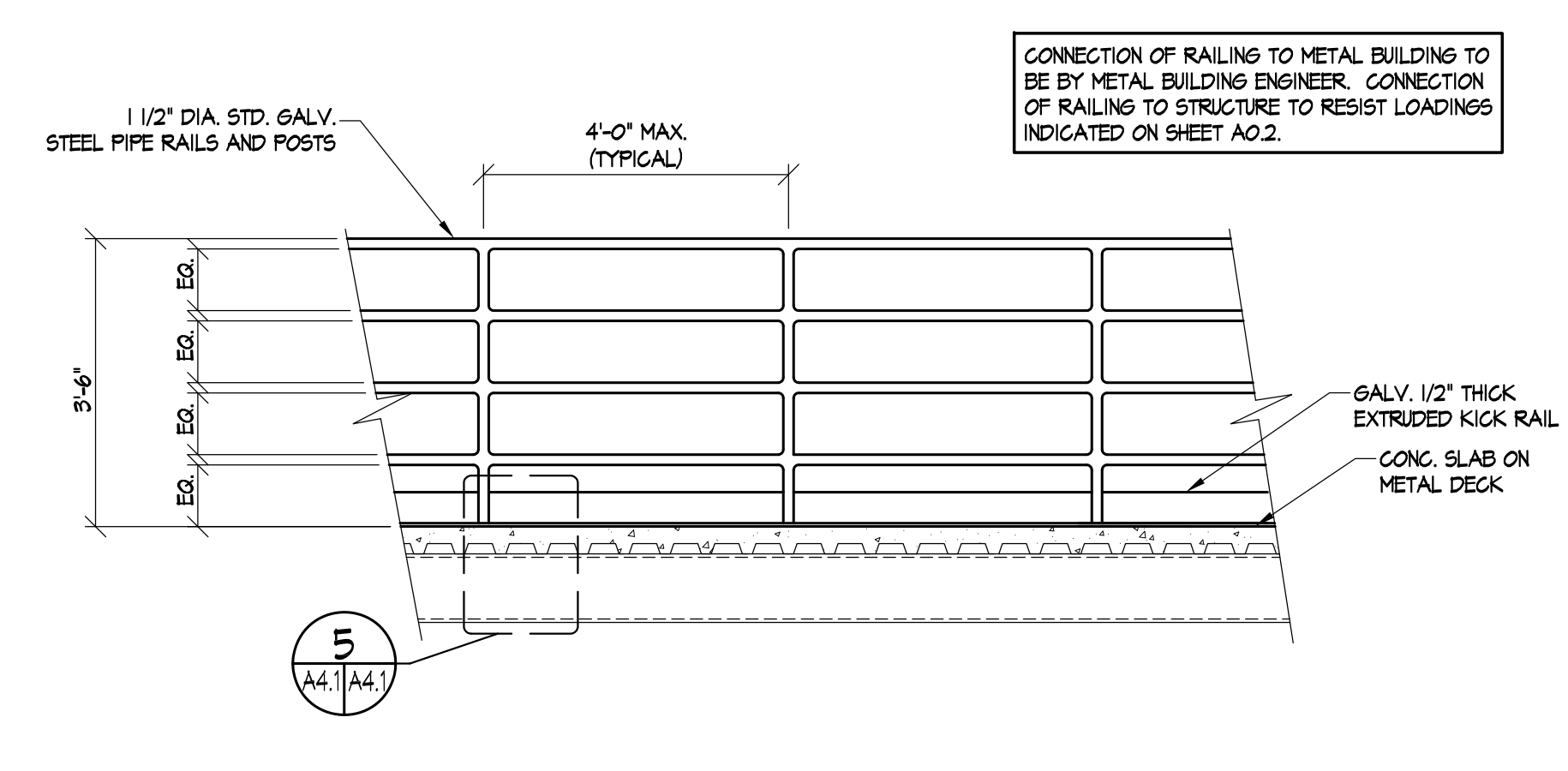

DETAIL TYPICAL GUARDRAIL
SCALE: 1/2" = 1'-0"

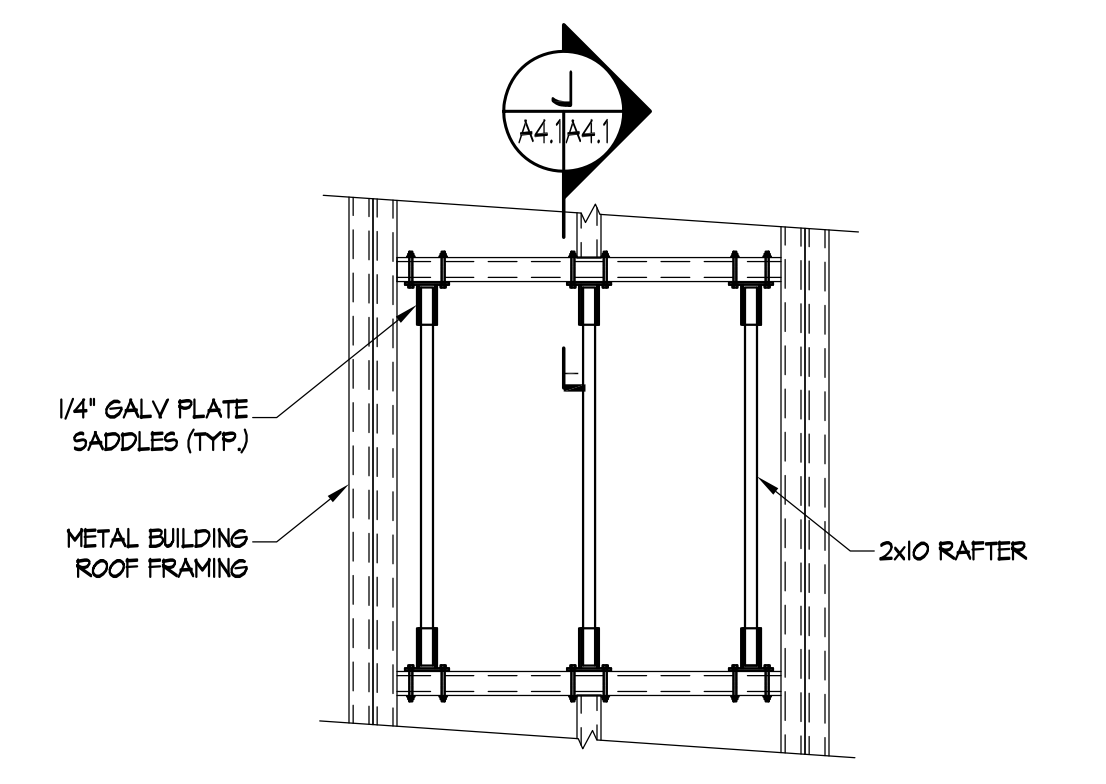

DETAIL CHOP OUT OPENING
SCALE: 1/2" = 1'-0"



DETAIL NFPA 1403 SIGNAGE
SCALE: 1/2" = 1'-0"

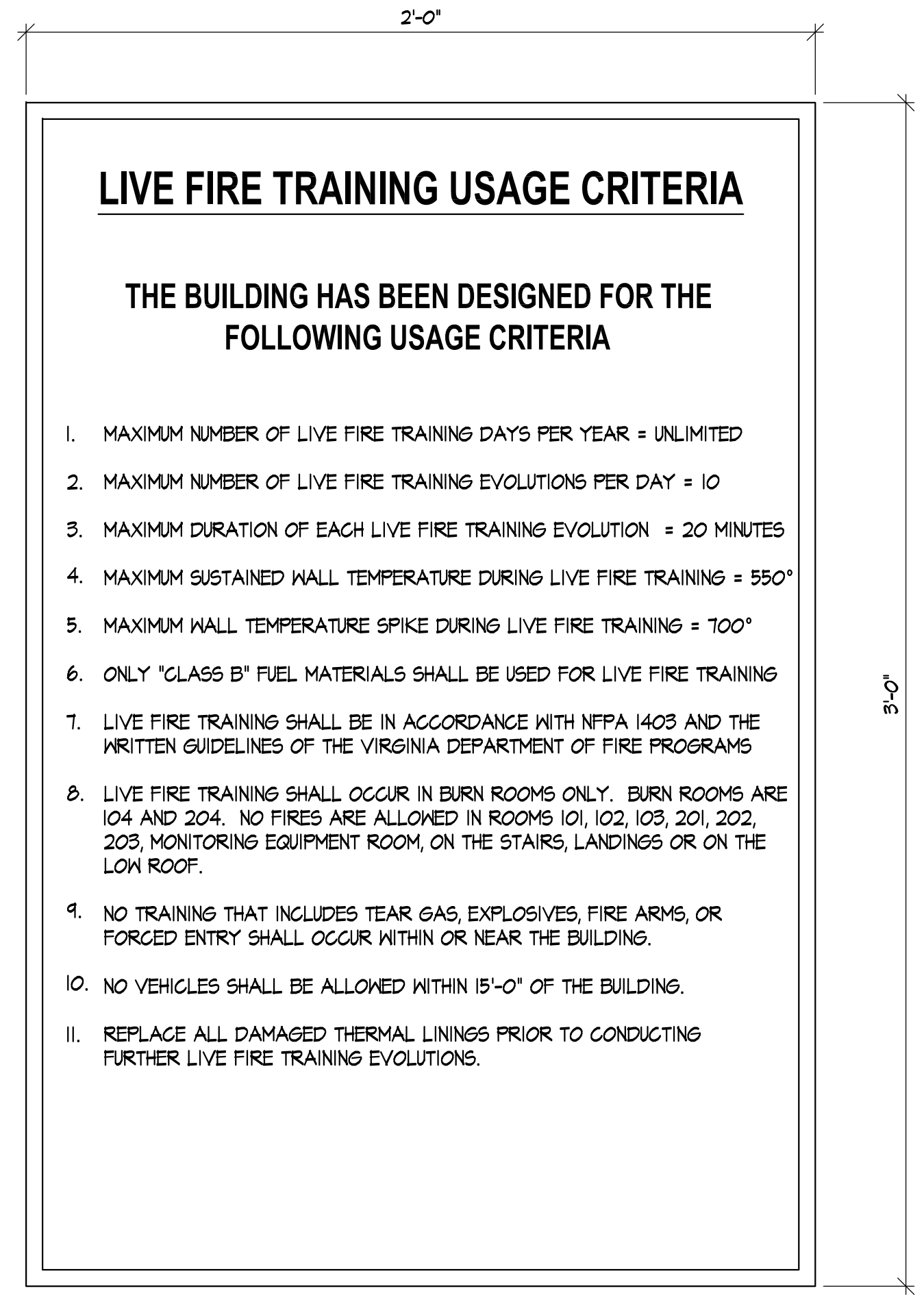

DETAIL USE CRITERIA SIGNAGE
SCALE: 3" = 1'-0"

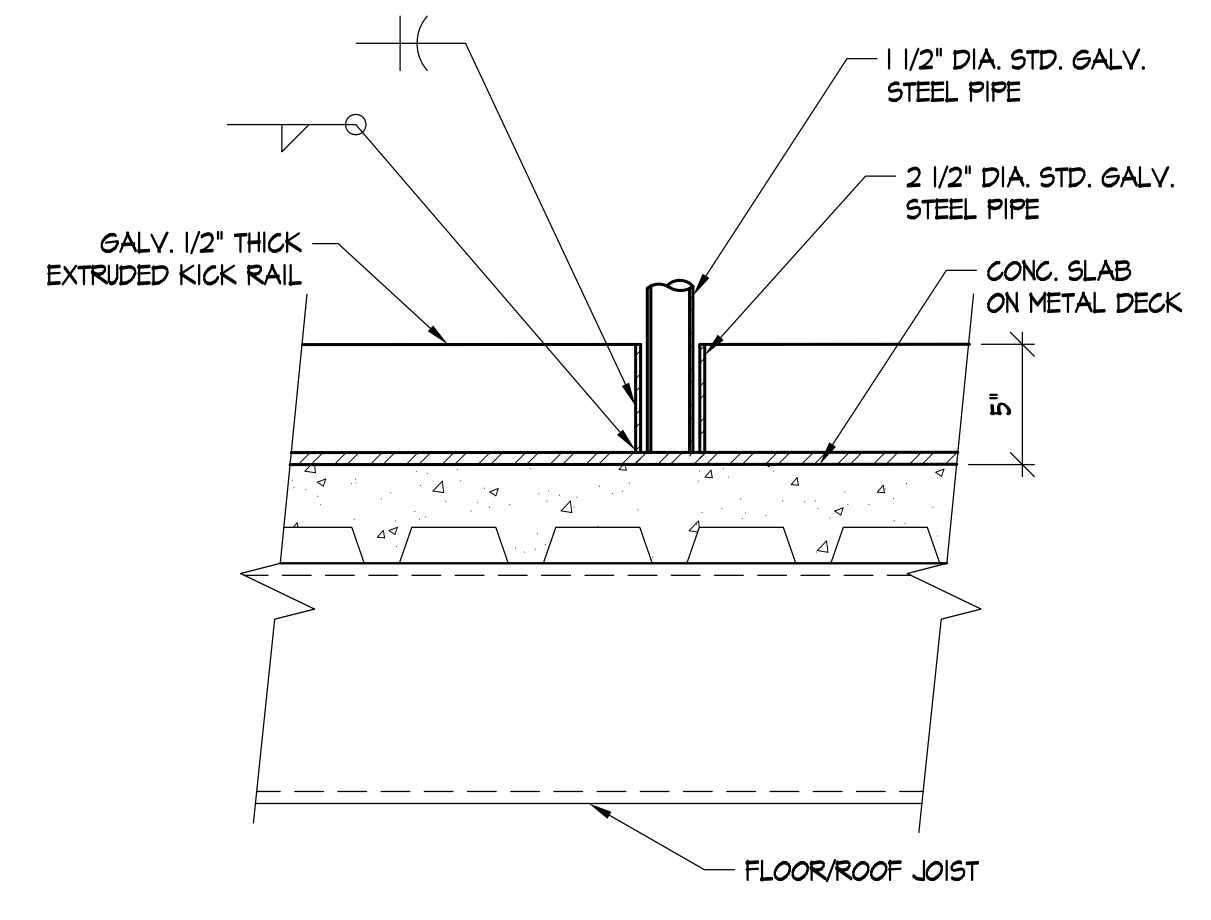

DETAIL REMOVABLE GUARDRAIL
SCALE: 1/2" = 1'-0"

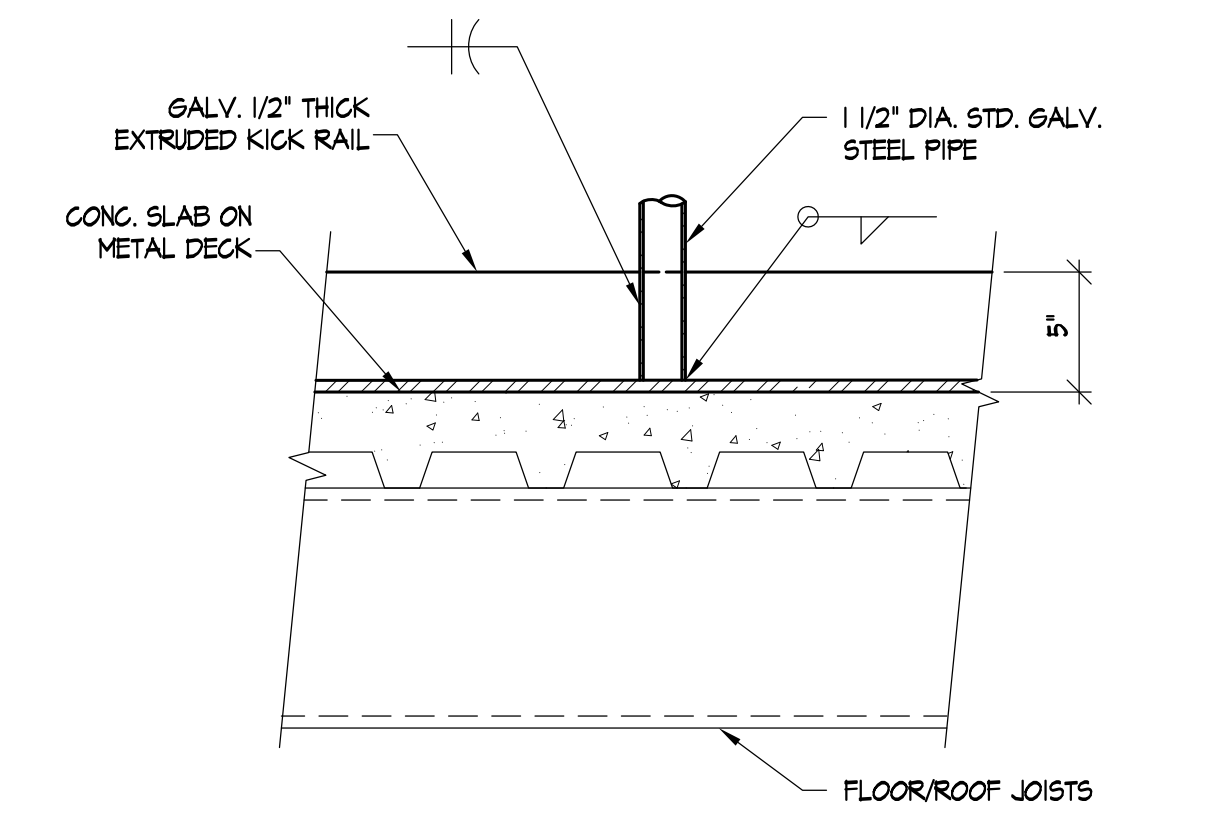

DETAIL TYP. GUARDRAIL
SCALE: 1/2" = 1'-0"

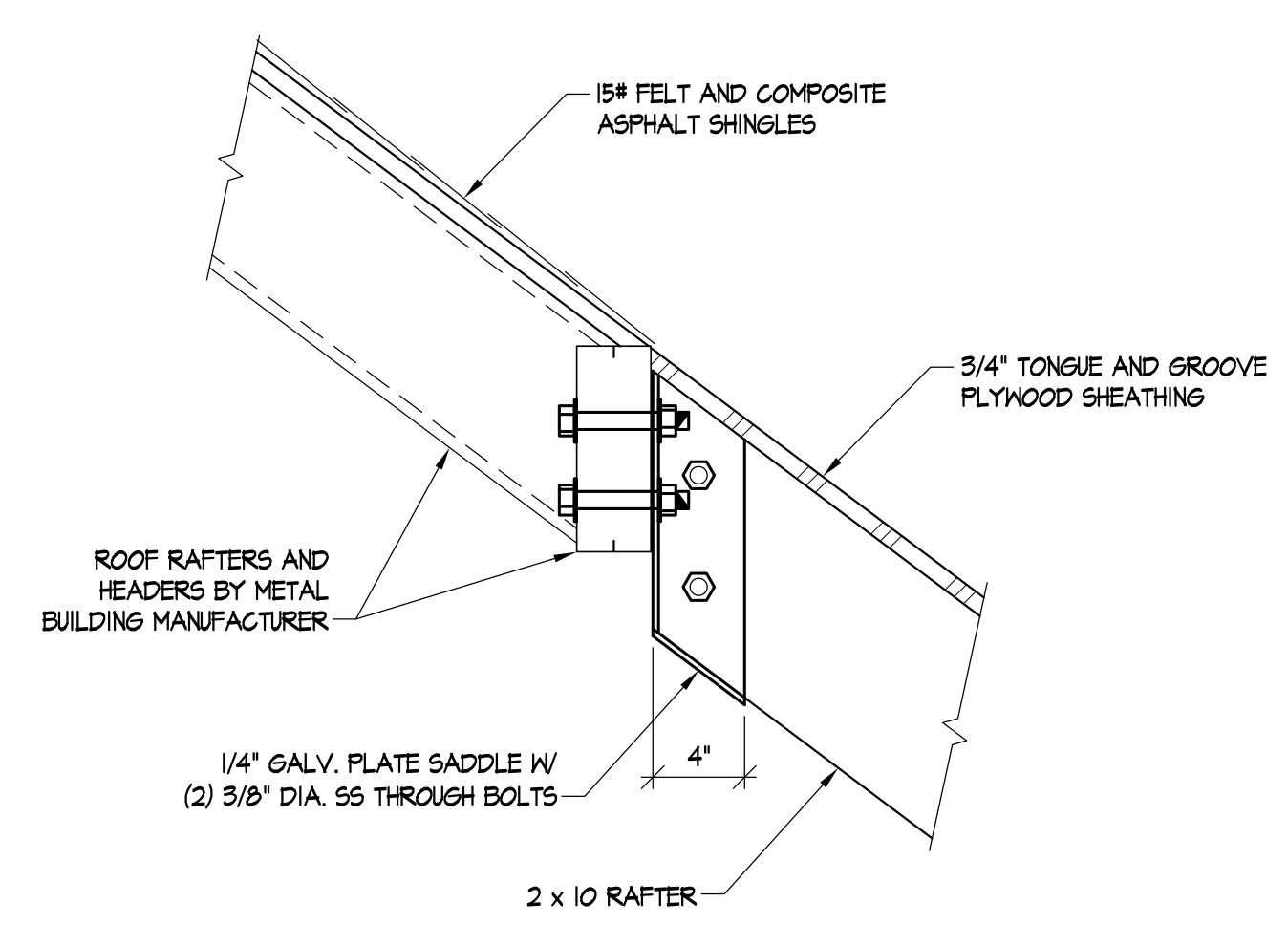

SECTION
SCALE: 1/2" = 1'-0"

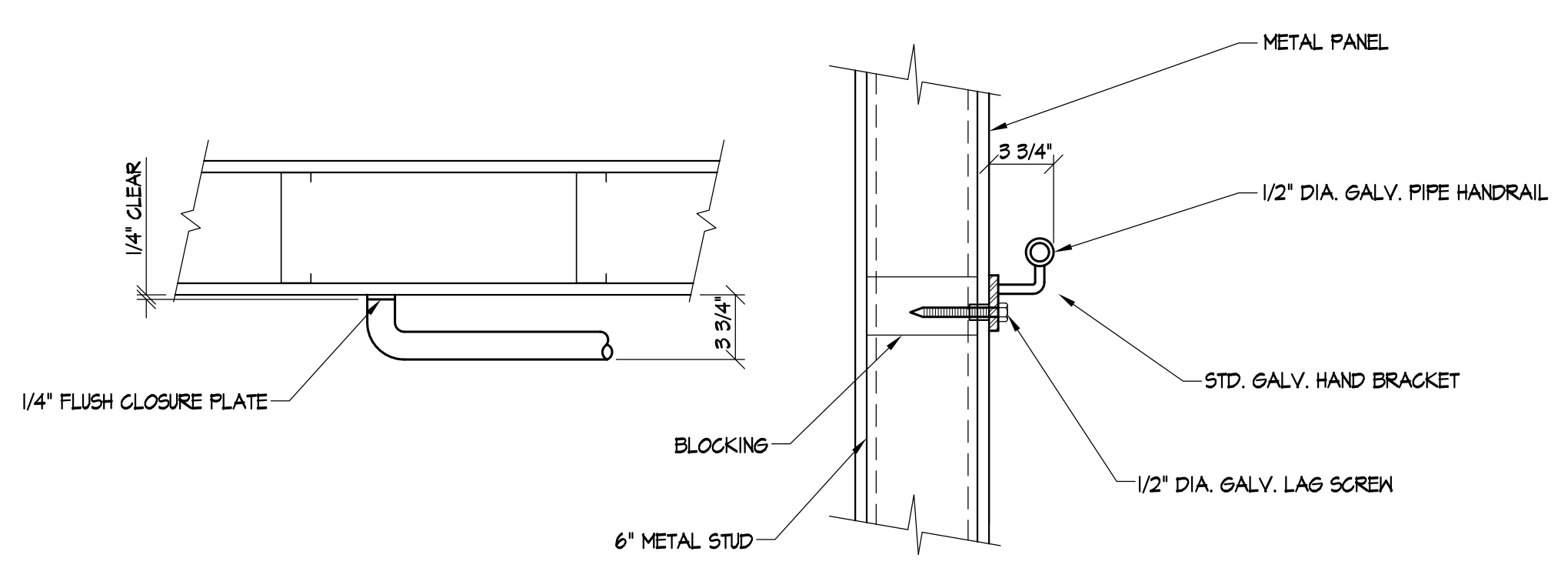

DETAIL INTERIOR HAND RAIL
SCALE: 1/2" = 1'-0"

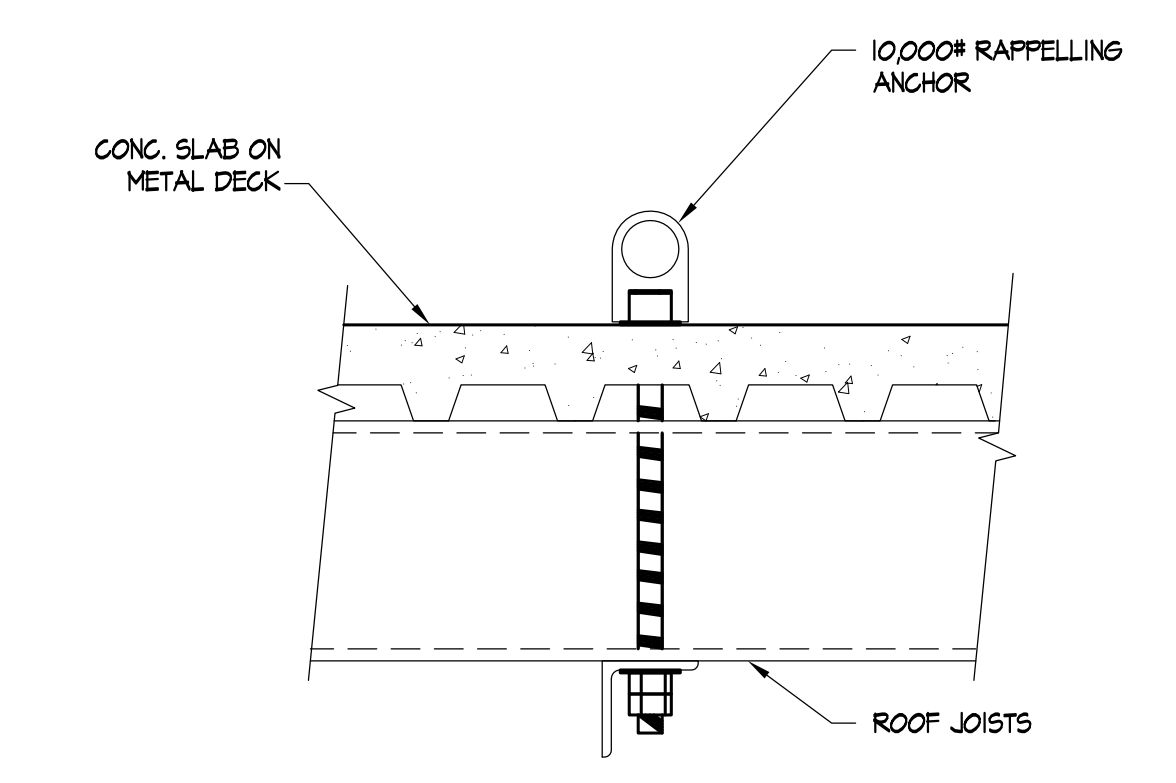

DETAIL RAPELLING ANCHOR INSTALLATION DETAILS
SCALE: 1/2" = 1'-0"

PRIME PROFESSIONAL FIRM LOGO

Project Title
**COMMONWEALTH OF VIRGINIA
BURN BUILDING PROP
PROTOTYPE 2
CLASS B FUEL**

SUB-CONSULTANT'S LOGO



Department of Fire Programs

NOT FOR CONSTRUCTION
THESE DRAWINGS ARE OWNED BY THE COMMONWEALTH OF VIRGINIA © 2013

No.	REVISIONS	Date

Sheet Title
SIGNAGE, RAILING & CHOPOUT DETAILS
CITY/COUNTY VIRGINIA
Drawn By: SJS Approved By: MAM
Checked By: SMF Date: 04/11/13

PROFESSIONAL SEAL

Sheet No.
A4.1
11 of 18

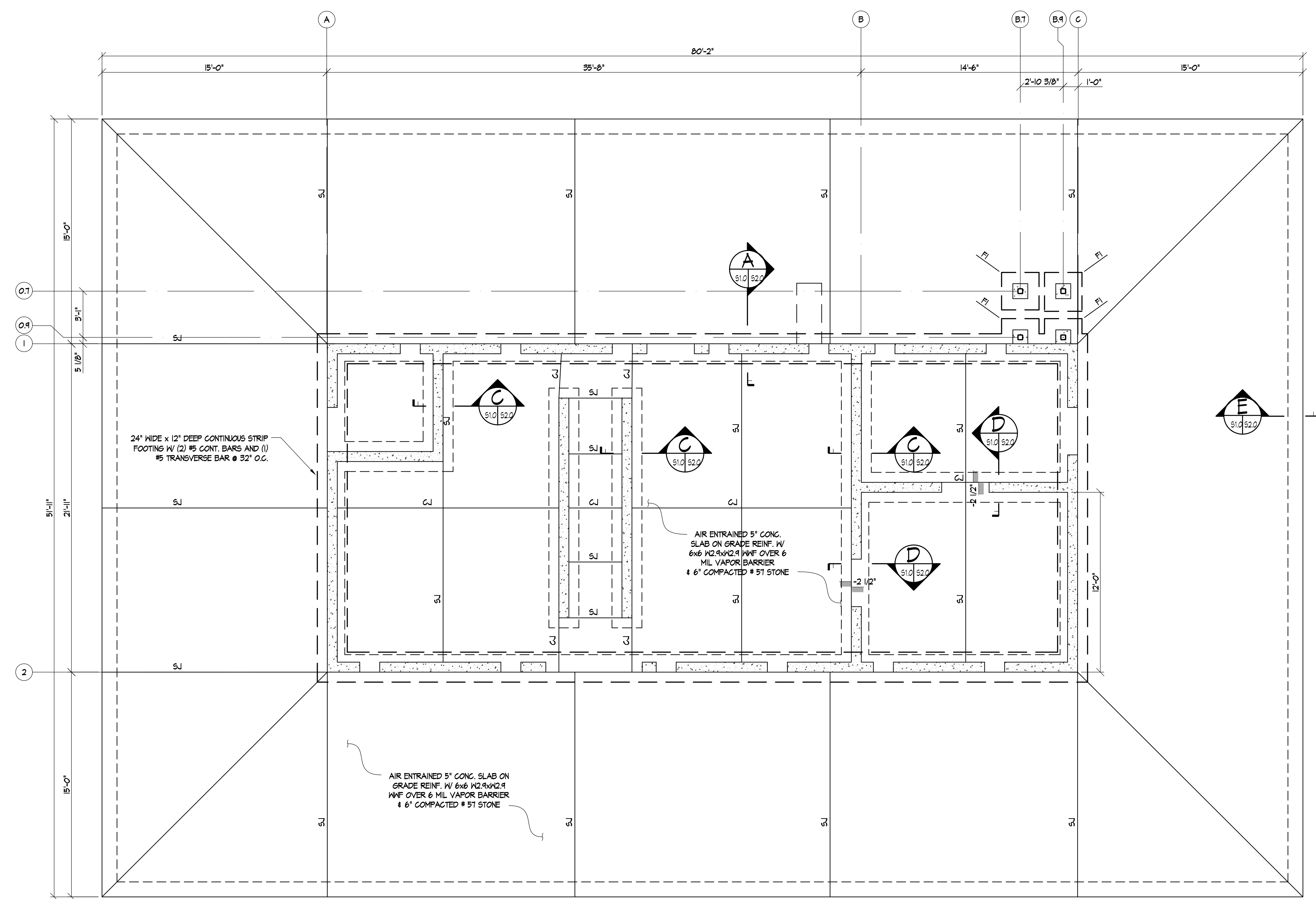

FOUNDATION PLAN
SCALE: 1/4" = 1'-0"

BEARING WALL DESIGN

- NOTES:**
1. FOUNDATION PROVIDED FOR PRE-ENGINEERED METAL BUILDING.
 2. SEE SHEET S11 FOR METAL BUILDING UTILIZING MAIN FRAME DESIGN.
 3. SEE SHEET A10 FOR SLAB ELEVATIONS AND SLOPES.
 4. SLOPE TOP & BOTTOM OF SLAB TO MAINTAIN THICKNESS INDICATED.

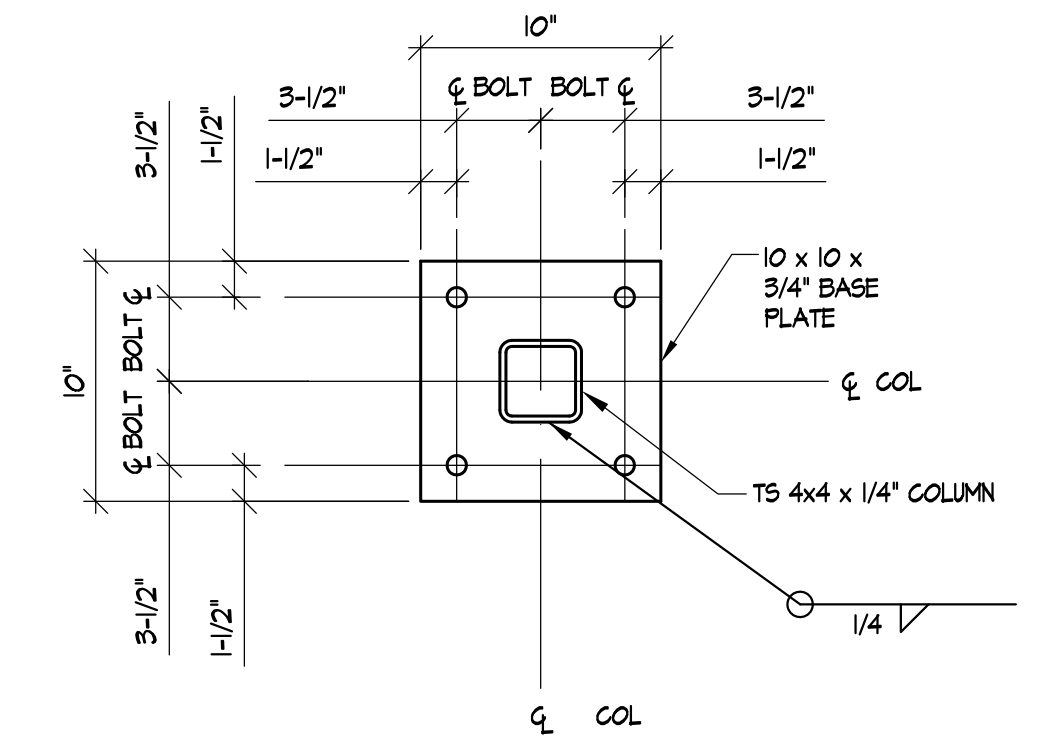

DETAIL
SCALE: 1 1/2" = 1'-0"

MARK	SIZE	DEPTH	BOTTOM REINFORCING	PEDESTAL		
				SIZE	DOWEL	TIES
F1	2'-6" x 2'-6"	1'-0"	(3) #5 E.H.	1'-0" x 1'-0"	(4) #6	#3 @ 6" O.C.



Project Title
COMMONWEALTH OF VIRGINIA
BURN BUILDING PROP
PROTOTYPE 2
CLASS B FUEL



Department of Fire Programs

NOT FOR CONSTRUCTION
THESE DRAWINGS ARE OWNED BY THE COMMONWEALTH OF VIRGINIA © 2013

No.	REVISIONS	Date

Sheet Title
FOUNDATION PLAN (BEARING WALL DESIGN) & COLUMN FTG SCHEDULE
CITY/COUNTY VIRGINIA
Drawn By: SJS Approved By: MAM
Checked By: SMF Date: 04/11/13



Sheet No.
S1.0
12 of 18

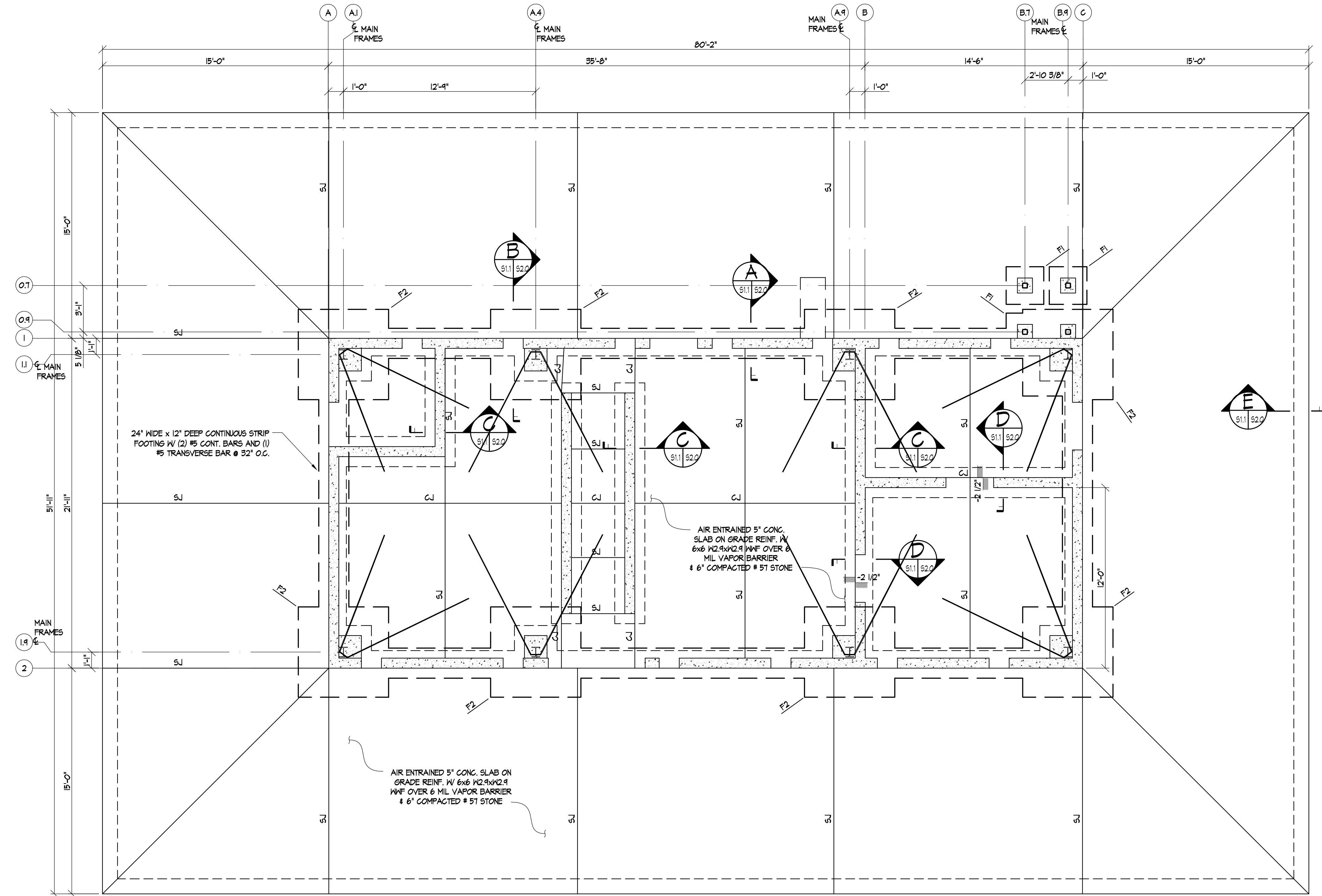

FOUNDATION PLAN

SCALE: 1/4" = 1'-0"

MAIN FRAME DESIGN

- NOTES:**
- FOUNDATION PROVIDED FOR PRE-ENGINEERED METAL BUILDING.
 - SEE SHEET S1.0 FOR METAL BUILDING UTILIZING EXTERIOR BEARING WALLS.
 - METAL BUILDING MANUFACTURERS UTILIZING MAIN FRAME SHALL UTILIZE LOCATIONS SHOWN.
 - SEE SHEET A1.0 FOR SLAB ELEVATIONS AND SLOPES.
 - SLOPE TOP & BOTTOM OF SLAB TO MAINTAIN THICKNESS INDICATED.

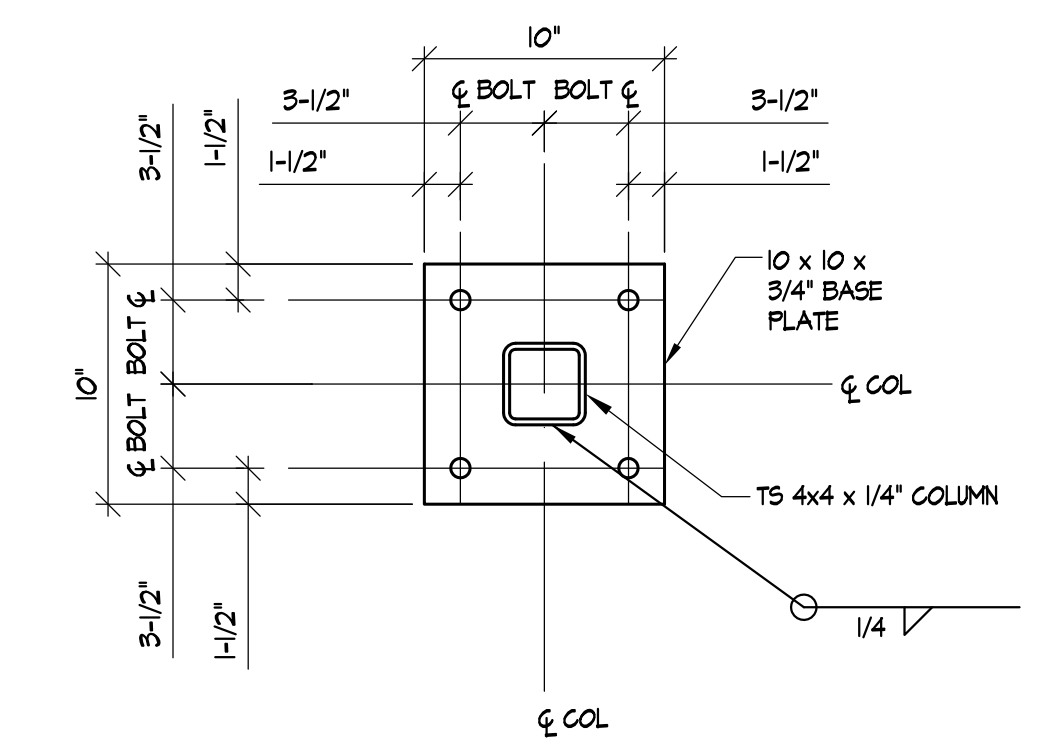

DETAIL
SCALE: 1 1/2" = 1'-0"
BASE PLATE

COLUMN FOOTING SCHEDULE

MARK	SIZE	DEPTH	BOTTOM REINFORCING	PEDESTAL		
				SIZE	DOWEL	TIES
F1	2'-6" x 2'-6"	1'-0"	(3) #5 E.M.	1'-0" x 1'-0"	(4) #6	#3 @ 6" o.c.
F2	6'-0" x 6'-0"	1'-2"	(7) #5 E.M.	1'-6" x 1'-6"	(2) #6	#3 @ 9" o.c.

NOTE: COLUMN SPREAD FOOTINGS DESIGNATED F2 ARE INTENDED FOR USE WITH METAL BUILDING CONSTRUCTION UTILIZING MAIN FRAME CONSTRUCTION ONLY

PRIME PROFESSIONAL FIRM LOGO

Project Title
COMMONWEALTH OF VIRGINIA
BURN BUILDING PROP
PROTOTYPE 2
CLASS B FUEL

SUB-CONSULTANT'S LOGO



Department of Fire Programs

NOT FOR CONSTRUCTION

THESE DRAWINGS ARE OWNED BY THE COMMONWEALTH OF VIRGINIA © 2013

No.	REVISIONS	Date

Sheet Title
FOUNDATION PLAN (MAIN FRAME DESIGN) & COLUMN FTG SCHEDULE
CITY/COUNTY VIRGINIA
Drawn By: SJS Approved By: MAM
Checked By: SMF Date: 04/11/13

PROFESSIONAL SEAL

Sheet No.
S1.1
13 of 18

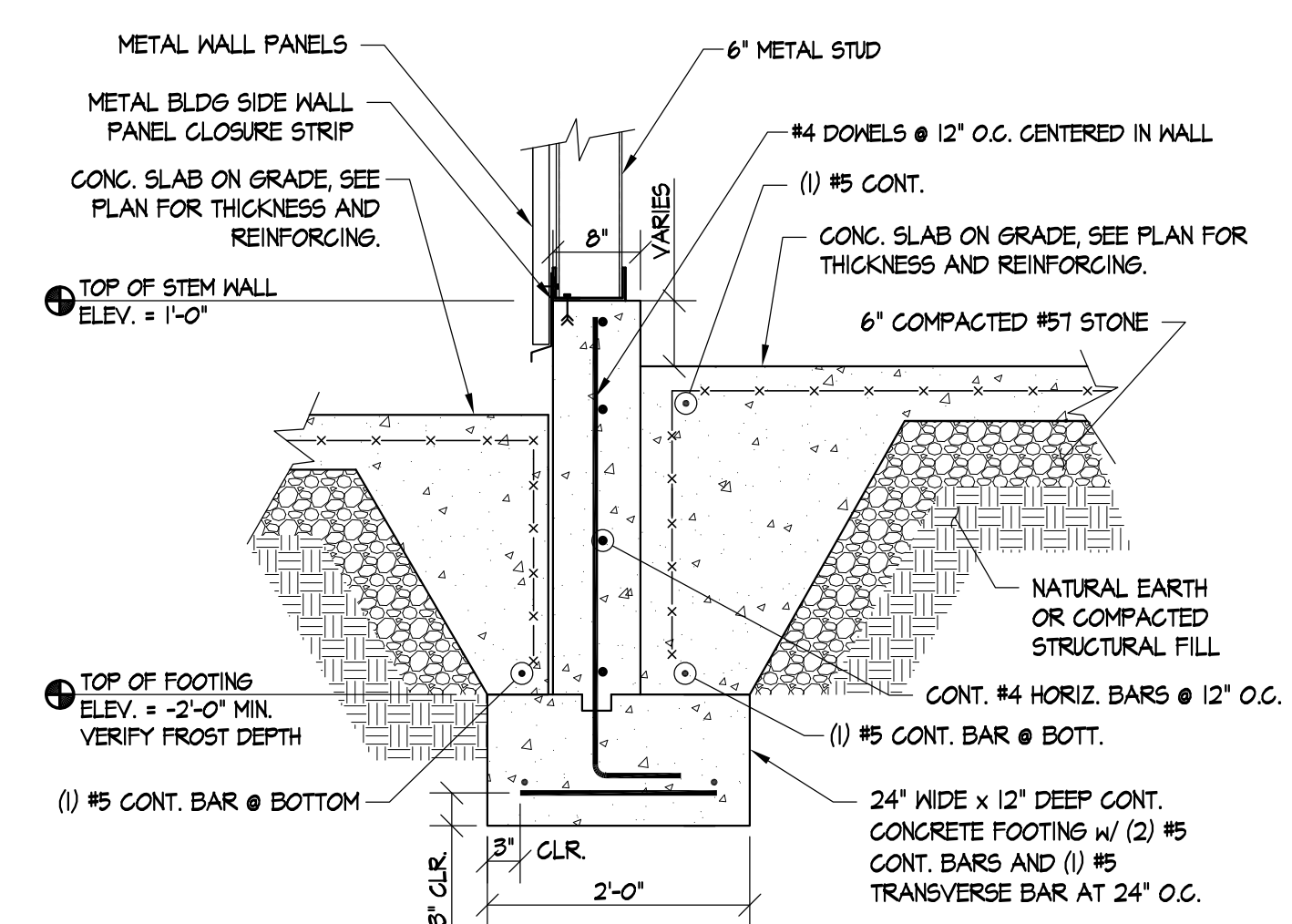

SECTION A
SCALE: 3/4" = 1'-0"
S1.0, S1.1

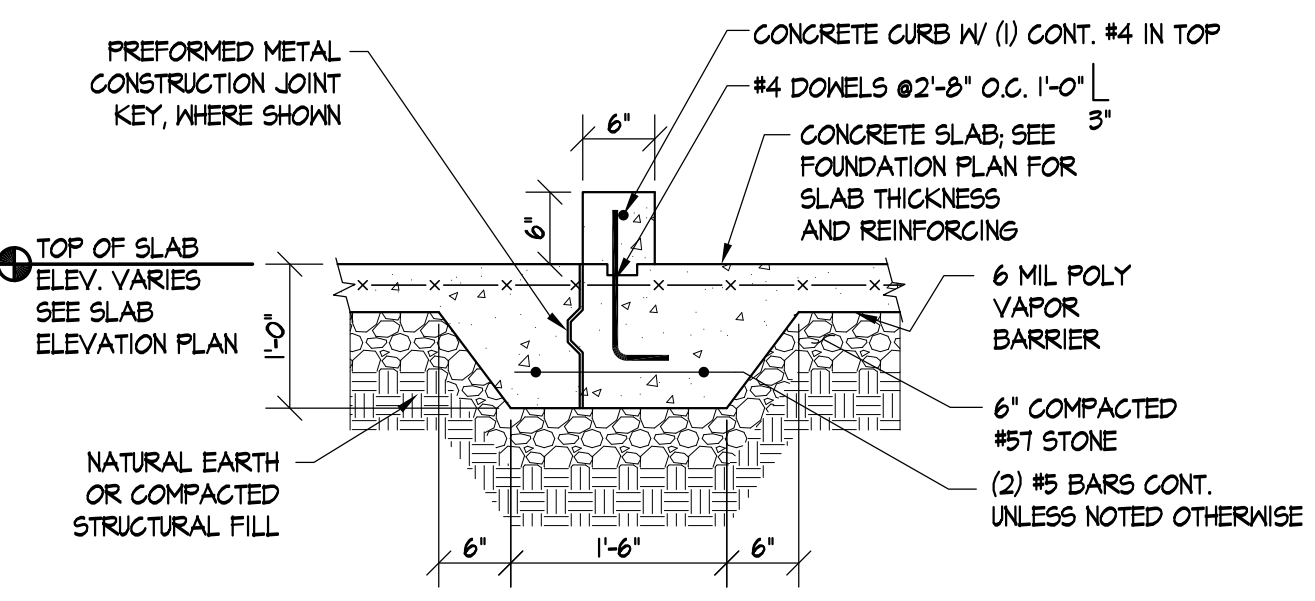

SECTION C
SCALE: 3/4" = 1'-0"
S1.0, S1.1

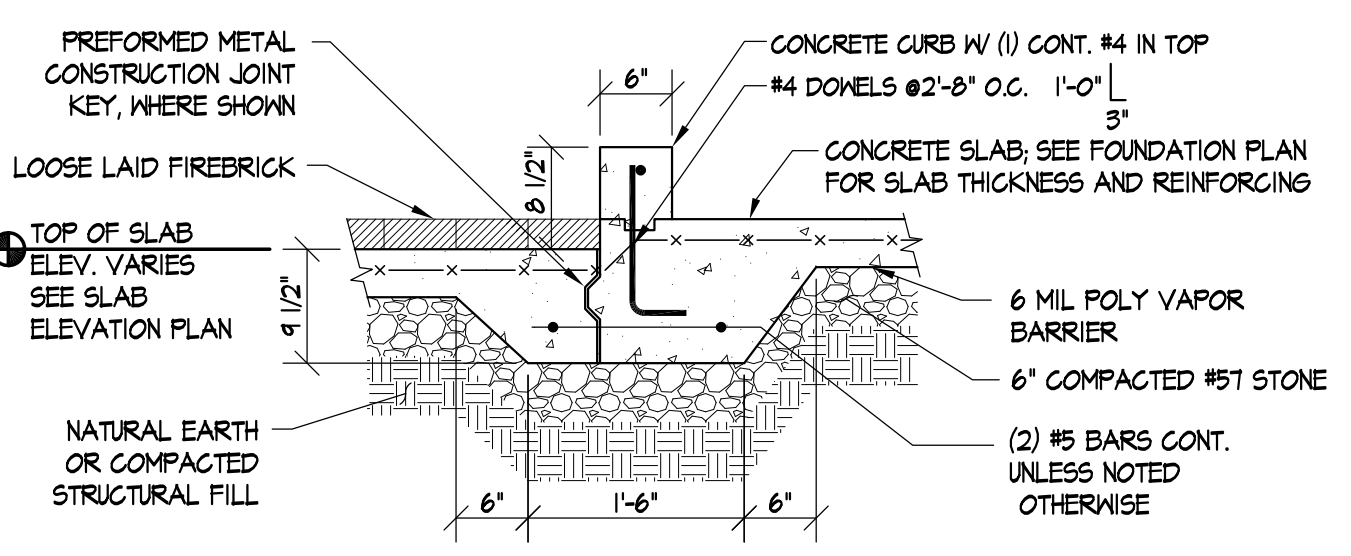

SECTION D
SCALE: 3/4" = 1'-0"
S1.0, S1.1

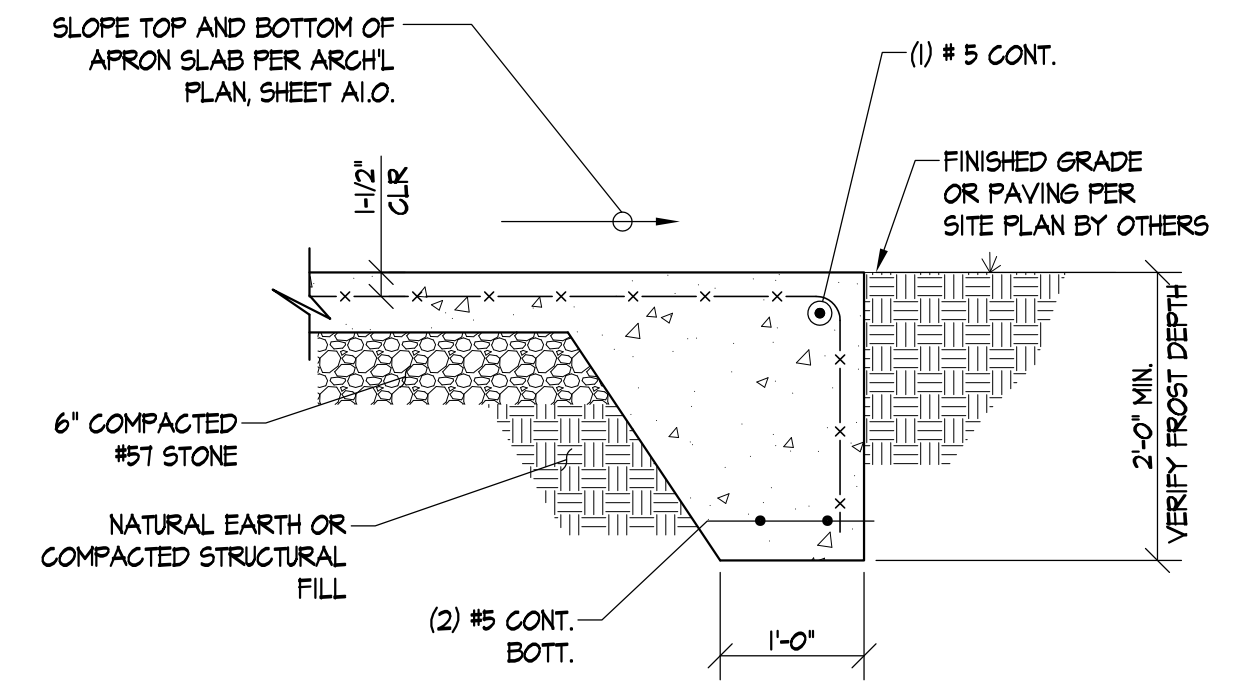

SECTION E
SCALE: 3/4" = 1'-0"
S1.0, S1.1

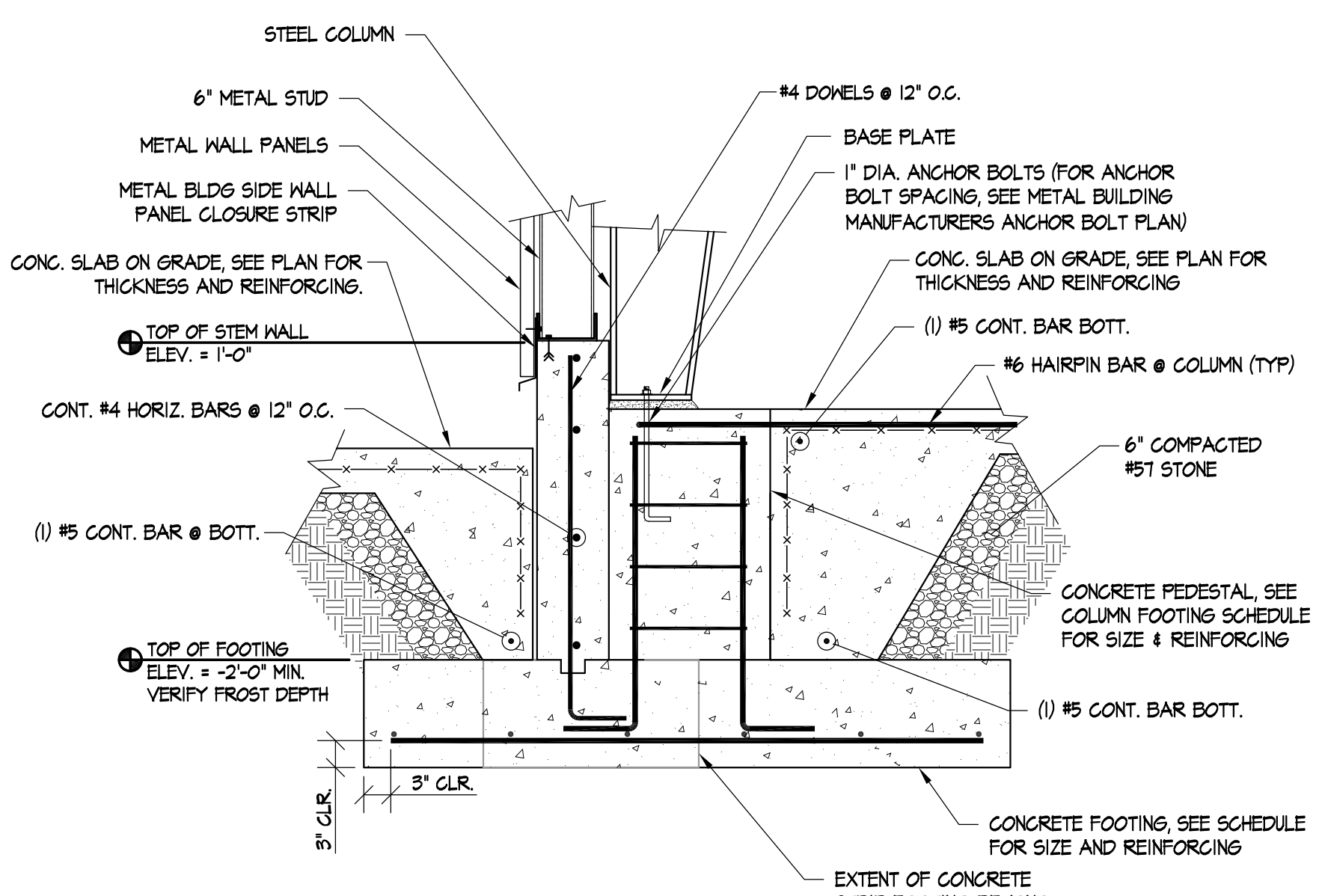

SECTION B
SCALE: 3/4" = 1'-0"
S1.1, S2.0

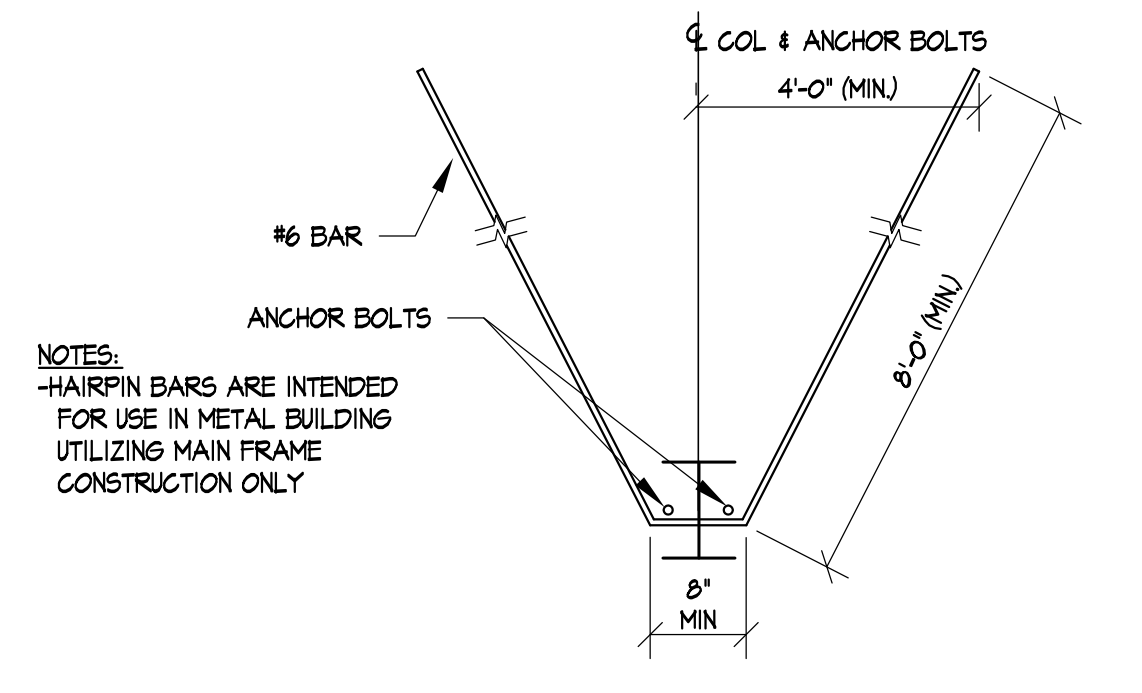

DETAIL
SCALE: 3/4" = 1'-0"
HAIRPIN BAR

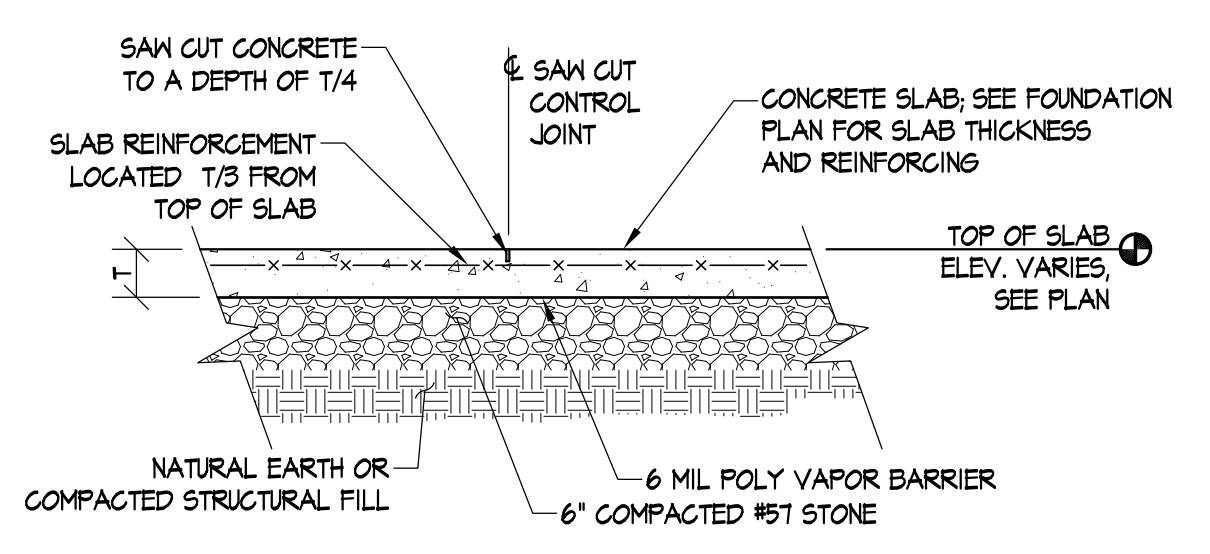

DETAIL
SCALE: 3/4" = 1'-0"
SAW CUT JOINT

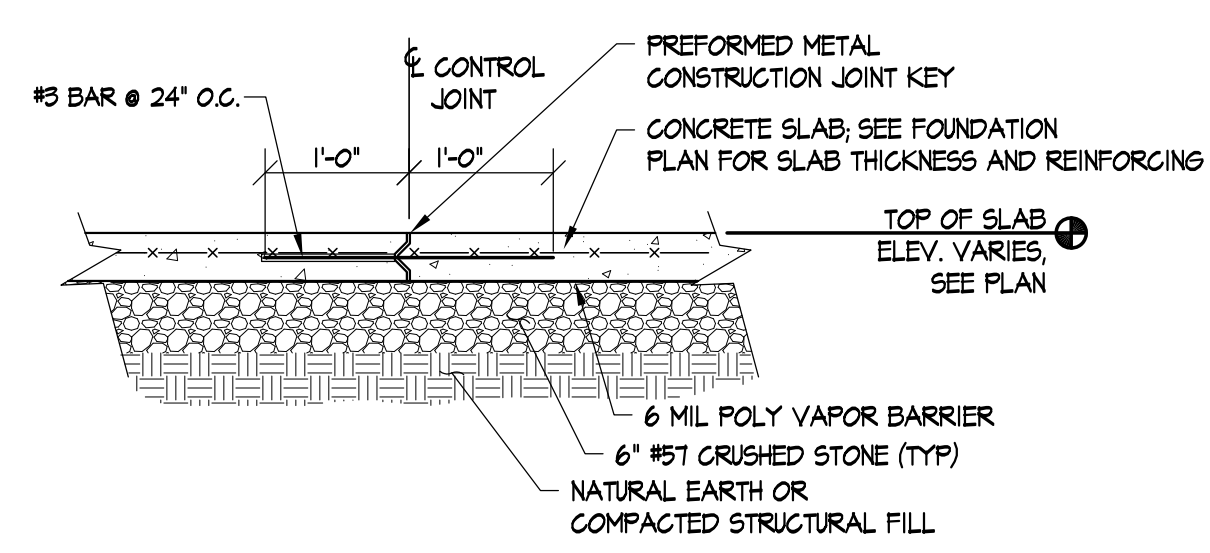

DETAIL
SCALE: 3/4" = 1'-0"
CONSTRUCTION JOINT

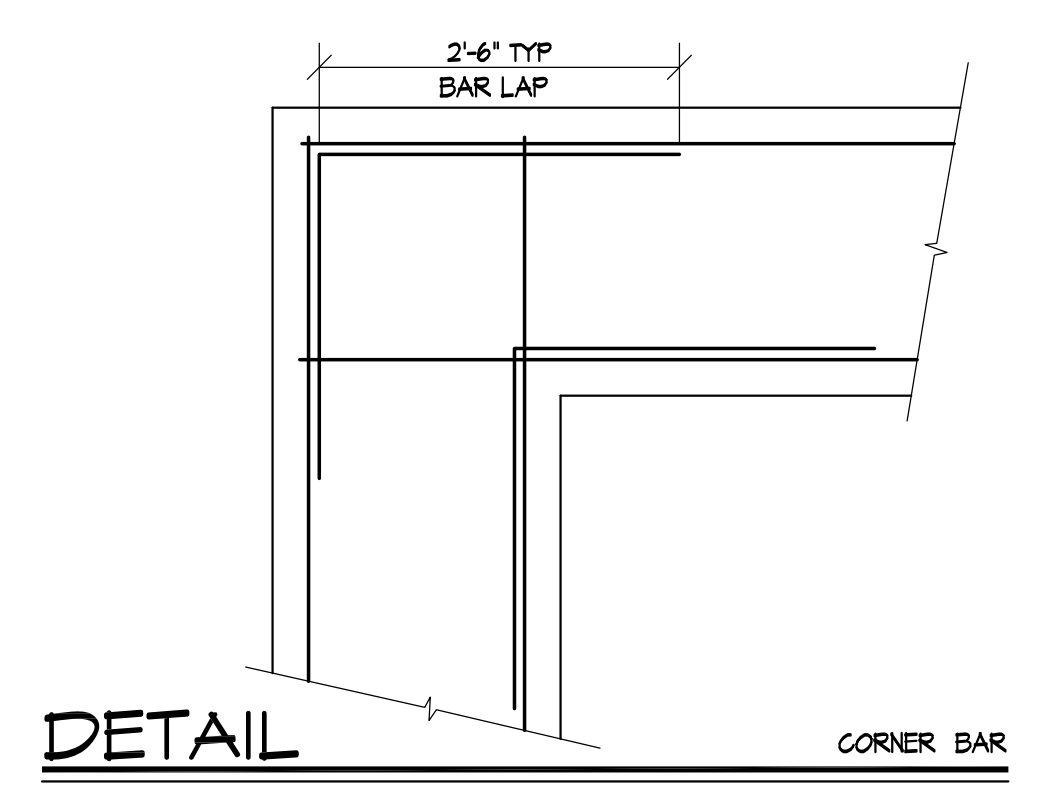

DETAIL
SCALE: 3/4" = 1'-0"
CORNER BAR
FOOTING REINF. SPLICE

PRIME PROFESSIONAL FIRM LOGO

Project Title
**COMMONWEALTH OF VIRGINIA
BURN BUILDING PROP
PROTOTYPE 2
CLASS B FUEL**

SUB-CONSULTANT'S LOGO



Department of Fire Programs

NOT FOR CONSTRUCTION
THESE DRAWINGS ARE OWNED BY THE COMMONWEALTH OF VIRGINIA © 2013

No.	REVISIONS	Date

Sheet Title
FOUNDATION SECTIONS & DETAILS
CITY/COUNTY VIRGINIA
Drawn By: SJS Approved By: MAM
Checked By: SMF Date: 04/11/13

PROFESSIONAL SEAL

Sheet No.
S2.0
14 of 18

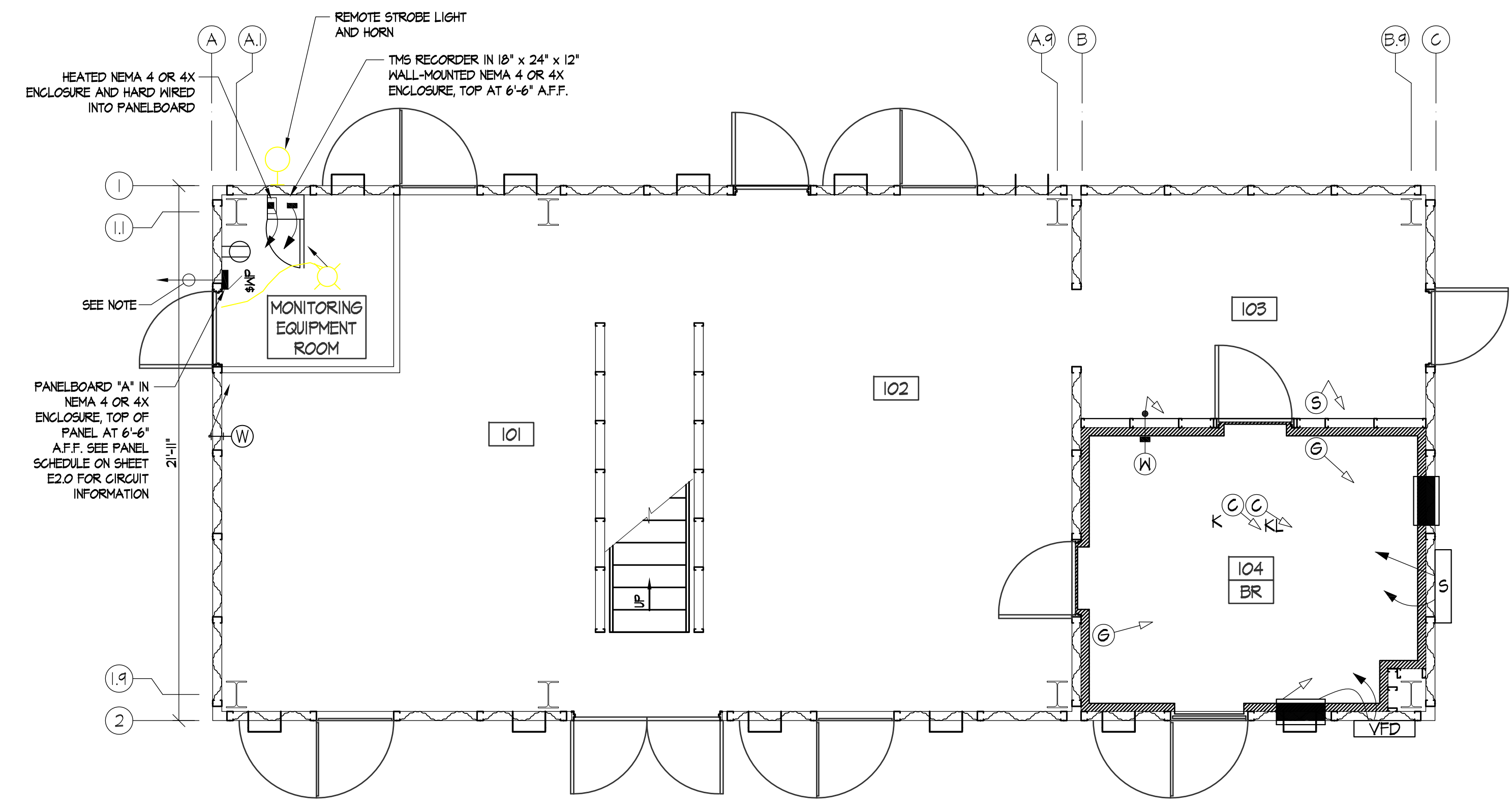

FIRST FLOOR ELECTRICAL PLAN
SCALE: 1/4" = 1'-0"

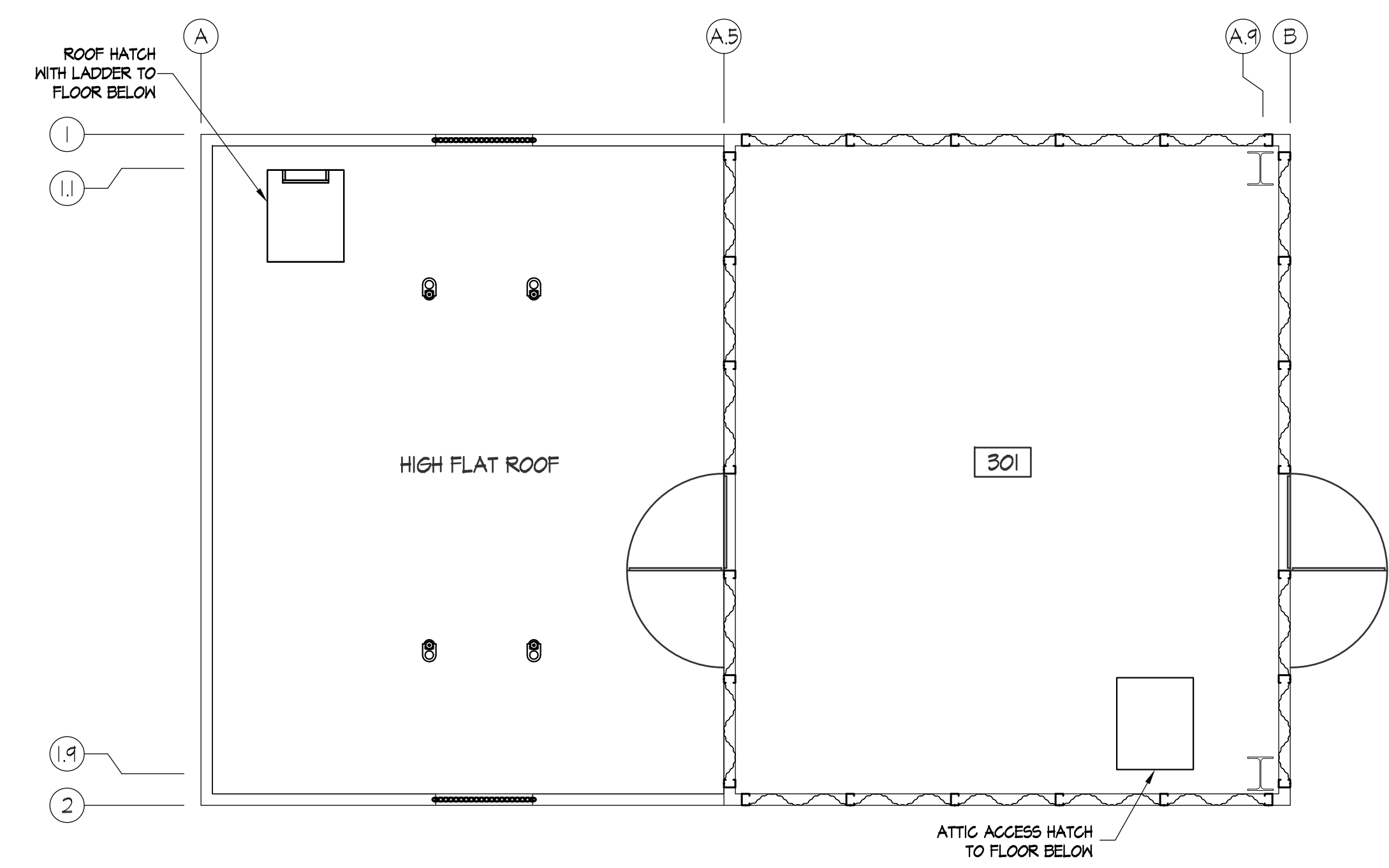

ATTIC FLOOR ELECTRICAL PLAN
SCALE: 1/4" = 1'-0"

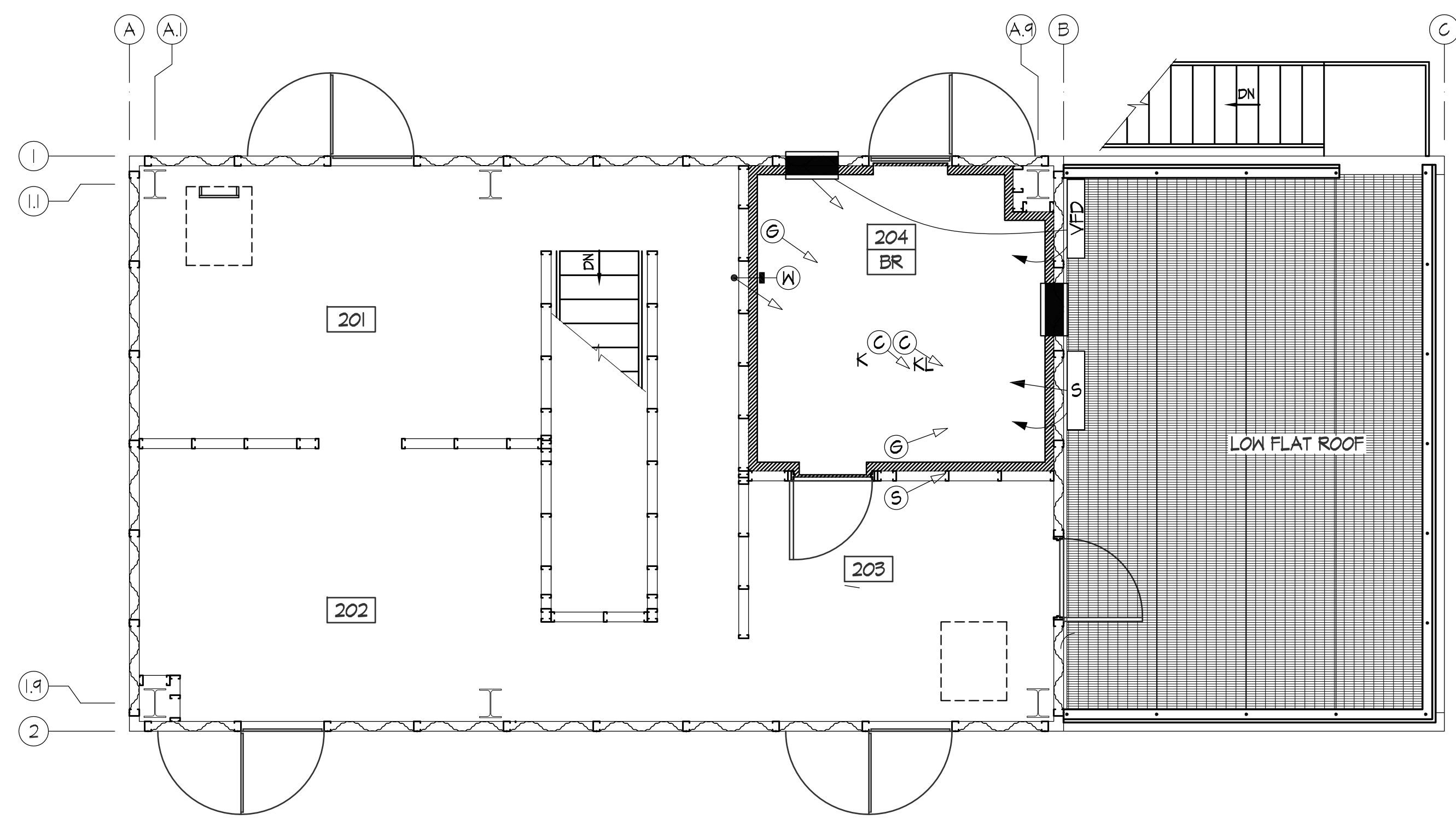

SECOND FLOOR ELECTRICAL PLAN
SCALE: 1/4" = 1'-0"

NOTES:

- ELECTRICAL PANEL "A" SHALL BE 120/208 VOLT 3 PHASE, 4 WIRE 200AMP MAIN CIRCUIT BREAKER, 30 POLE PANEL. CONTRACTOR SHALL COORDINATE POWER SOURCE TO PANEL AND SIZE FEEDER TO ACCOMMODATE VOLTAGE DROP. CONDUIT SHALL BE RUN AT A MINIMUM OF 36" BELOW GRADE AND SHALL BE PVC COATED RIGID STEEL.
- CONTRACTOR SHALL PROVIDE AN ALTERNATE PRICE FOR INSTALLATION OF EXTERIOR DUPLEX RECEPTACLES. RECEPTACLES SHALL BE RECESSED MOUNTED. PROVIDE CAST IRON RECEPTACLE WITH DIE CAST ALUMINUM COVERPLATE. DUPLEX RECEPTACLE SHALL BE CERAMIC AND HEAVY DUTY TYPE.
- ALL ELECTRICAL FIXTURES SHALL BE G.F.C.I.
- ALL WIRING SHALL COMPLY WITH THE APPLICABLE NATIONAL, STATE, AND LOCAL ELECTRICAL CODES. USE MINIMUM OF #12 AWG IN 1/2 INCH RIGID STEEL CONDUITS, UNLESS OTHERWISE NOTED.

ABBREVIATIONS:

- A. AMPERE (S)
- A.F.F. ABOVE FINISHED FLOOR
- A.I.C. AMPERE INTERRUPTING CAPACITY
- AWG AMERICAN WIRE GAUGE
- G.F.I. GROUND FAULT INTERRUPT
- GND GROUND
- MCB MAIN CIRCUIT BREAKER
- WP WEATHERPROOF (NEMA 4X)
- TL. THERMAL LINING
- T.M.S. TEMPERATURE MONITORING SYSTEM
- V VOLT (S)
- W WATT
- WP WEATHERPROOF (NEMA 4X)

SYMBOLS:

- WEATHERPROOF CEILING MOUNTED, 100W, 120V, INCANDESCENT FIXTURE.
- WEATHERPROOF DUPLEX RECEPTACLE, 20A, 125V, GROUNDING TYPE HAVING NEMA TYPE 5-20 R. CONFIGURATION, SURFACE MOUNTED, 18" MOUNTING HEIGHT A.F.F.
- JUNCTION BOX
- CONDUIT TURNED UP
- CONDUIT TURNED DOWN
- CONDUIT RUN TO RECORDER FOR TEMPERATURE MONITORING SYSTEM U.N.O.
- CONDUIT RUN TO SLAVE PANEL
- WALL-MOUNTED TYPE K DUPLEX THERMOCOUPLE, 60" A.F.F. SEE 1-16/17 U.O.N.
- RECESSED CEILING-MOUNTED TYPE K DUPLEX THERMOCOUPLE. SEE 2-16/17
- RECESSED CEILING-MOUNTED TYPE K DUPLEX THERMOCOUPLE. SEE 2-16/17
- PLACED BEHIND INSULATION OF THERMAL LINING. SEE 2-16/17
- EXISTING METER
- BRANCH CIRCUIT CONDUIT WITH 2 #12 AWG + GROUND WIRE, U.N.O., RUN EXPOSED TO PANELBOARD CONNECTION POINT
- CONNECTION POINT
- GAS SENSOR
- EMERGENCY STOP
- FIRE PROP SLAVE PANEL
- FIRE PROP VFD PANEL
- REMOTE STROBE LIGHT & HORN
- EXHAUST FAN

PRIME PROFESSIONAL FIRM LOGO

Project Title
**COMMONWEALTH OF VIRGINIA
BURN BUILDING PROP
PROTOTYPE 2
CLASS B FUEL**

SUB-CONSULTANT'S LOGO



**Department
of
Fire Programs**

**NOT FOR
CONSTRUCTION**

THESE DRAWINGS ARE OWNED BY THE COMMONWEALTH OF VIRGINIA © 2013

No.	REVISIONS	Date

Sheet Title
**ELECTRICAL FLOOR &
ATTIC PLANS, NOTES,
SYMBOLS & ABBREVIATIONS**
CITY/COUNTY VIRGINIA

Drawn By: SJS Approved By: MAM
Checked By: SMF Date: 04/11/13

PROFESSIONAL SEAL

Sheet No.
E1.0
16 of 18

PRIME PROFESSIONAL FIRM LOGO

Project Title
**COMMONWEALTH OF VIRGINIA
 BURN BUILDING PROP
 PROTOTYPE 2
 CLASS B FUEL**

SUB-CONSULTANT'S LOGO



Department of Fire Programs

NOT FOR CONSTRUCTION
 THESE DRAWINGS ARE OWNED BY THE COMMONWEALTH OF VIRGINIA © 2013

No.	REVISIONS	Date

Sheet Title
ELECTRICAL DETAILS & PANELBOARD SCHEDULE
 CITY/COUNTY VIRGINIA
 Drawn By: SJS Approved By: MAM
 Checked By: SMF Date: 04/11/13

Sheet No.
E2.0
 17 of 18

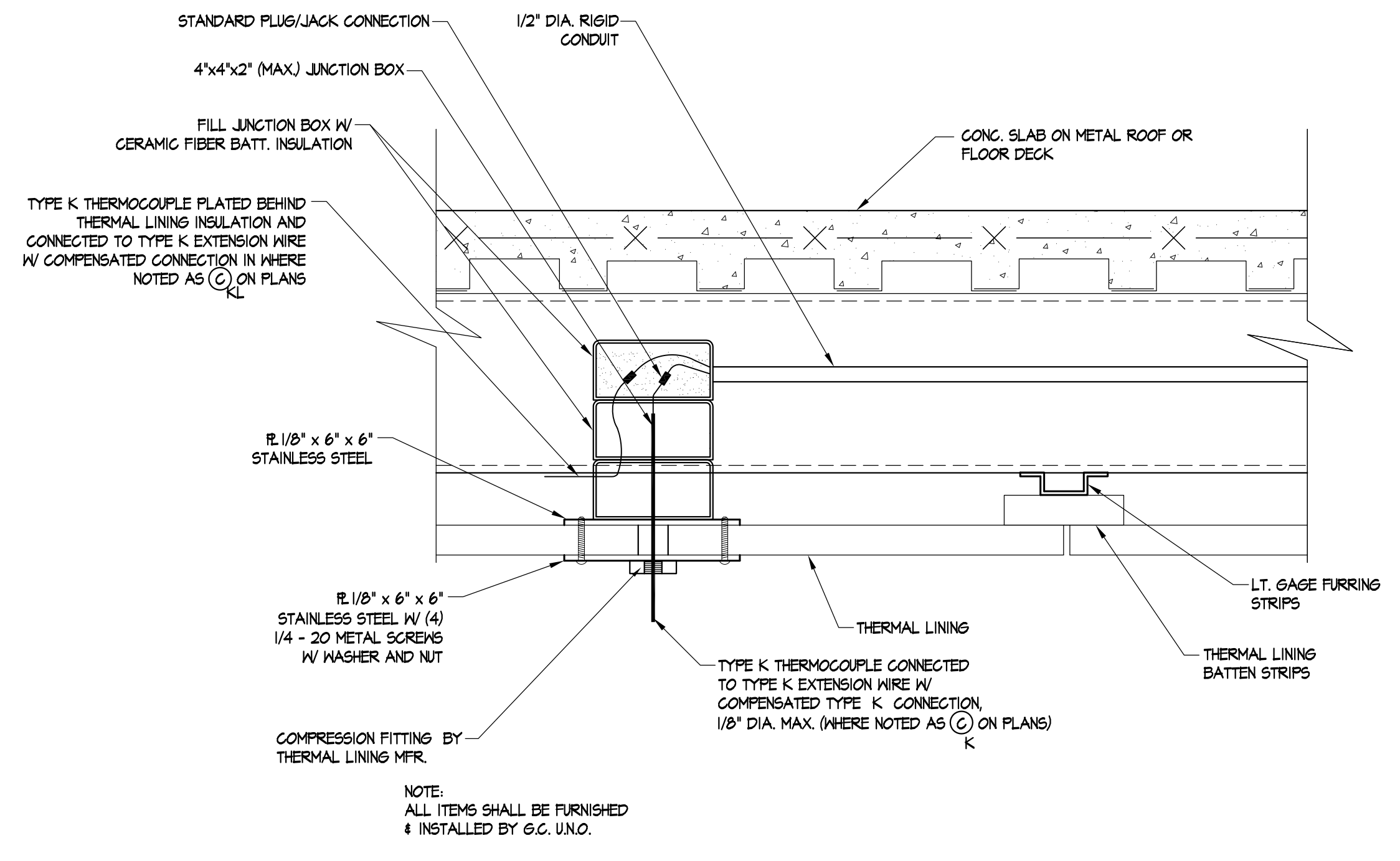

DETAIL
 SCALE: 3" = 1'-0"

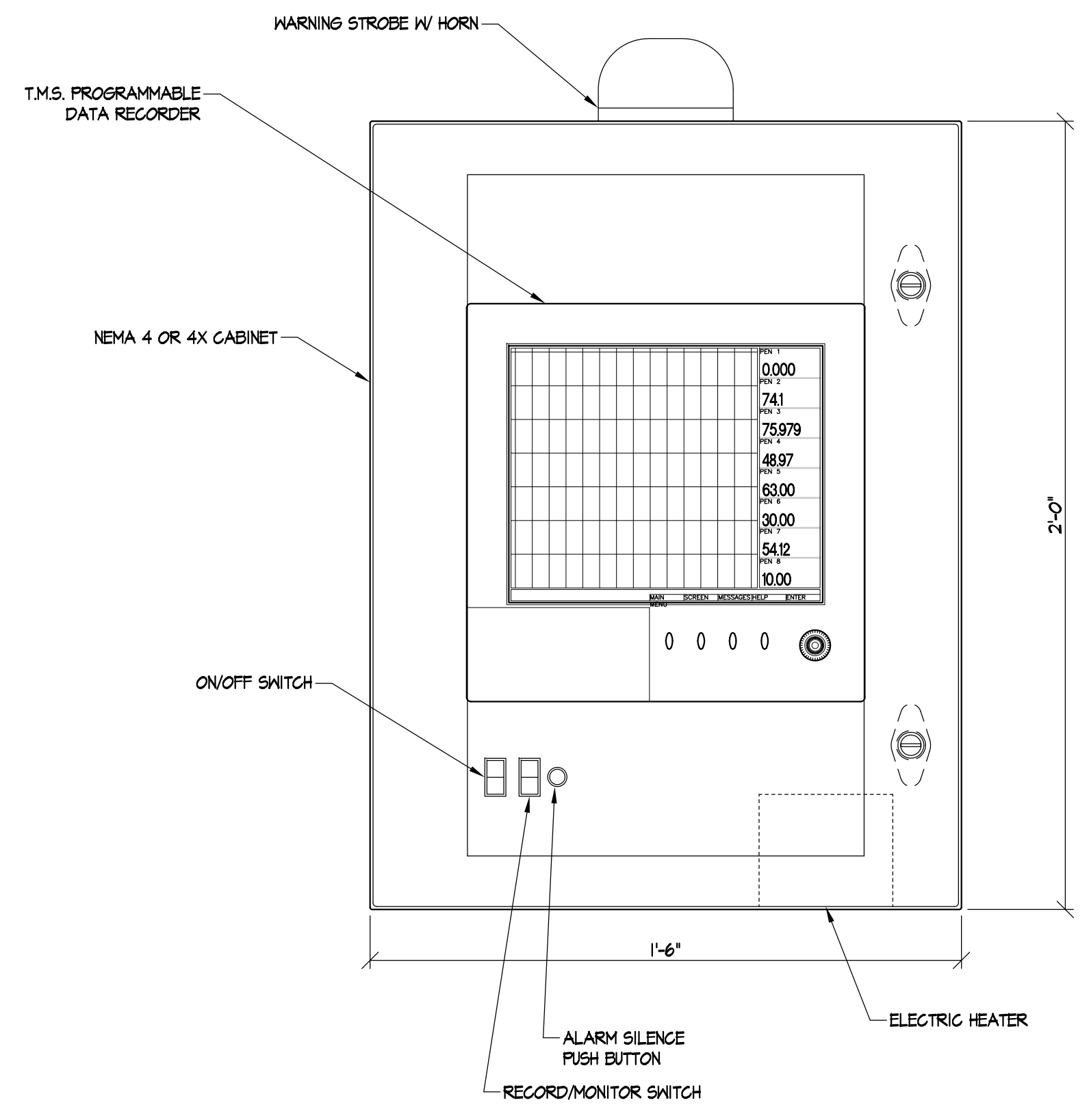

ELEVATION
 T.M.S. INDICATOR PANEL
 SCALE: 3" = 1'-0"

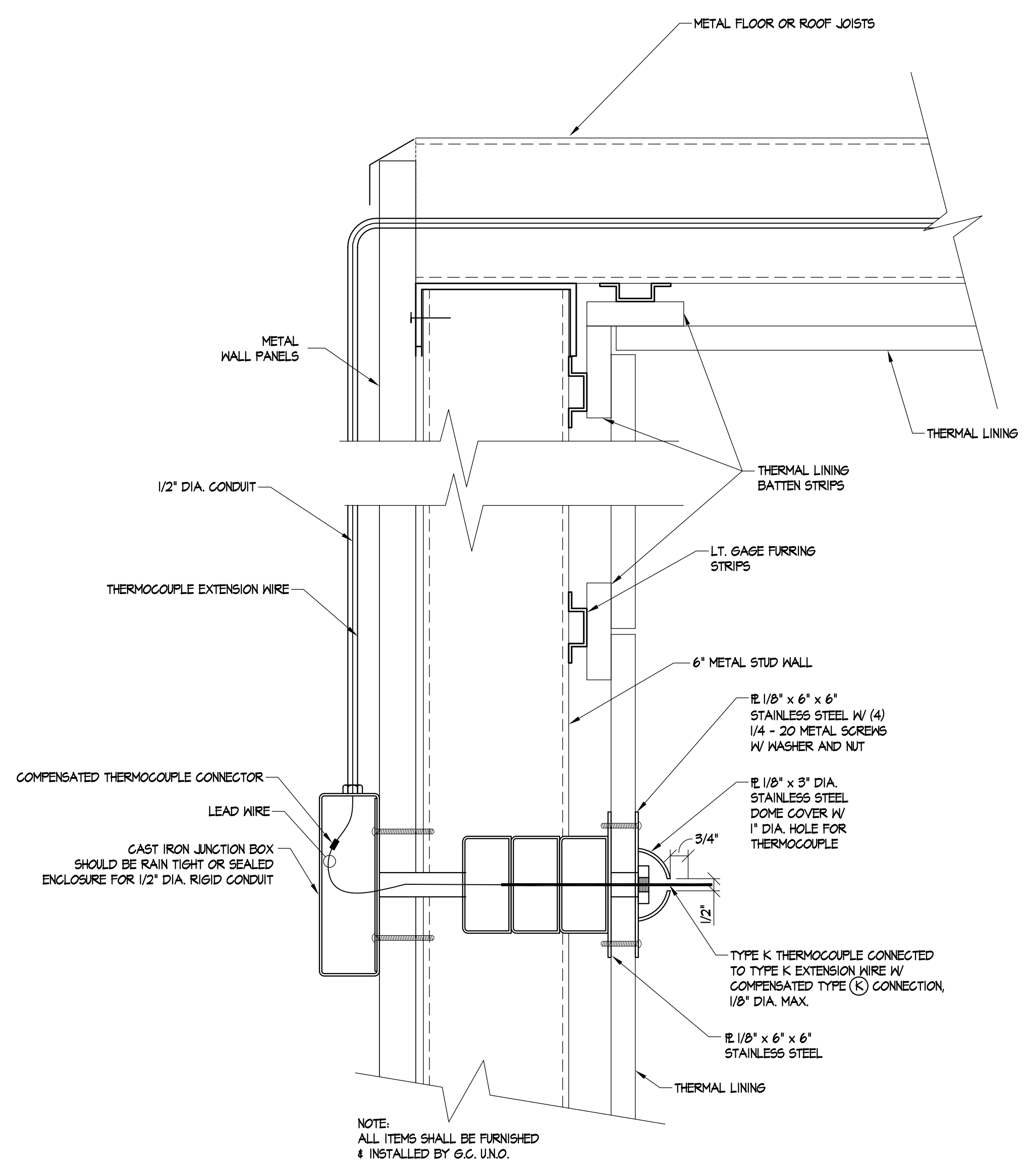

DETAIL
 SCALE: 3" = 1'-0"

PANELBOARD SCHEDULE LP-1										
LOCATION: 105			FED FROM: SHED MSB			□ 1 - GFI				
SERVICE: 208Y/120V 3-P 4-W			NEUTRAL BUS: 100%			□ 2 - SHUNT TRIP				
MAIN LUGS: A			GROUND BUS: STANDARD			□ 3 - BREAKER LOCK				
MAIN BUS TYPE: -			MOUNTING: SURFACE			□ 4 - HACR				
INTERRUPT RATING: - AIC			ENCLOSURE: NEMA 1							
DESCRIPTION	CCT. NO.	CIRCUIT BREAKER	CIRCUIT LOAD	CONNECTED LOAD (VA)			CIRCUIT LOAD	CIRCUIT BREAKER	CCT. NO.	DESCRIPTION
				A	B	C				
T.M.S. PANEL	1	20A-IP	500	680			180	20A-IP	2	LIGHT & RECEPTACLE
	3	20A-IP						20A-IP	4	
	5	20A-IP						20A-IP	6	
	7	20A-IP						20A-IP	8	
	9	20A-IP						20A-IP	10	
	11	20A-IP						20A-IP	12	
	13	20A-IP						20A-IP	14	
	15	20A-IP						20A-IP	16	
	17	20A-IP						20A-IP	18	
	19	20A-IP						20A-IP	20	
	21	20A-IP						20A-IP	22	
	23	20A-IP						20A-IP	24	
	25	20A-IP						20A-IP	26	
	27	20A-IP						20A-IP	28	
	29	20A-IP						20A-IP	30	
				680						

TOTAL VA PER PHASE

LIGHTING DEMAND = 125% PER NEC 220-10(b)
 RECEPTACLE DEMAND LOAD PER NEC TABLE 220-12

PROFESSIONAL SEAL

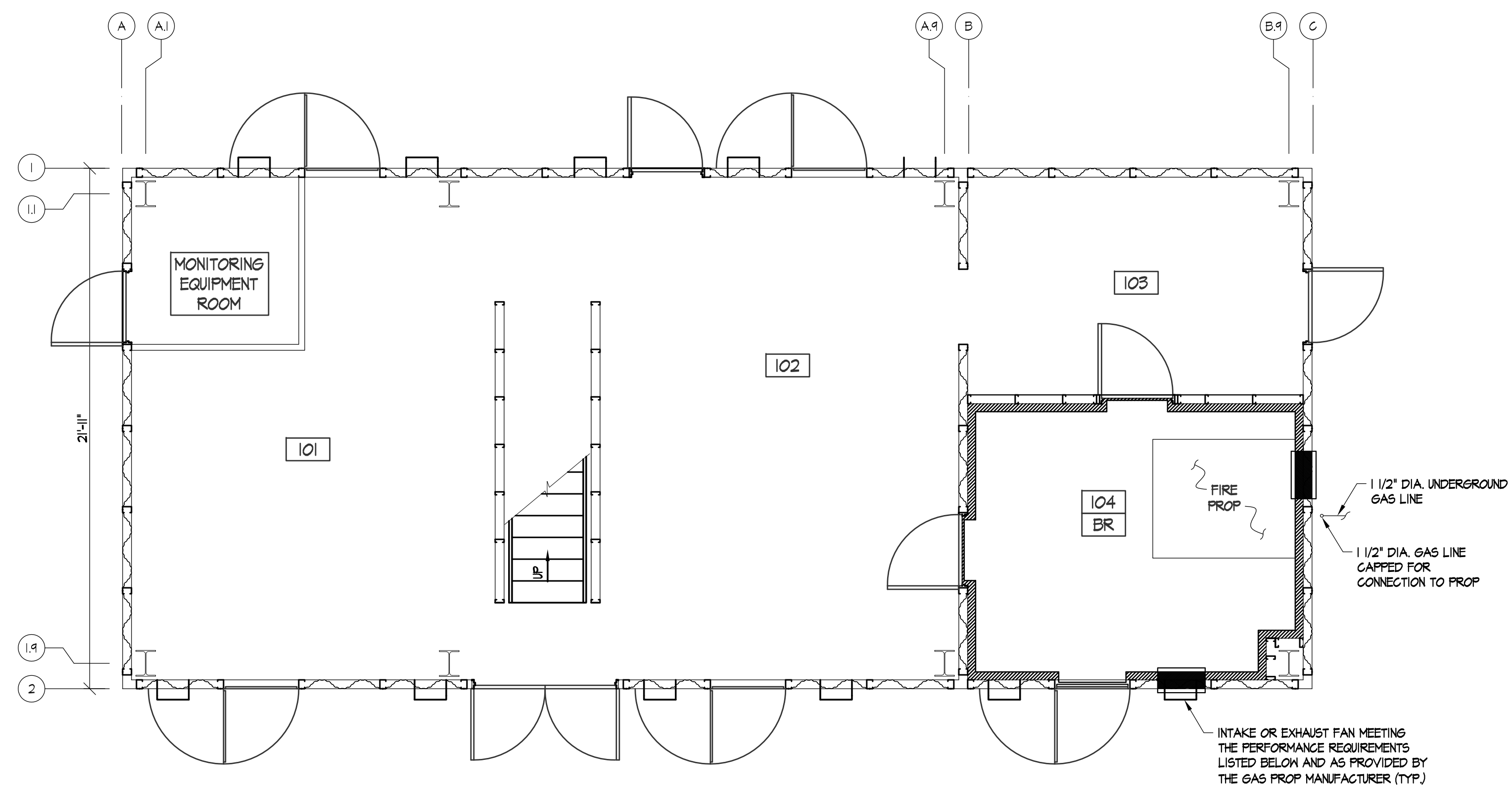

FIRST FLOOR MECHANICAL PLAN
SCALE: 1/4" = 1'-0"

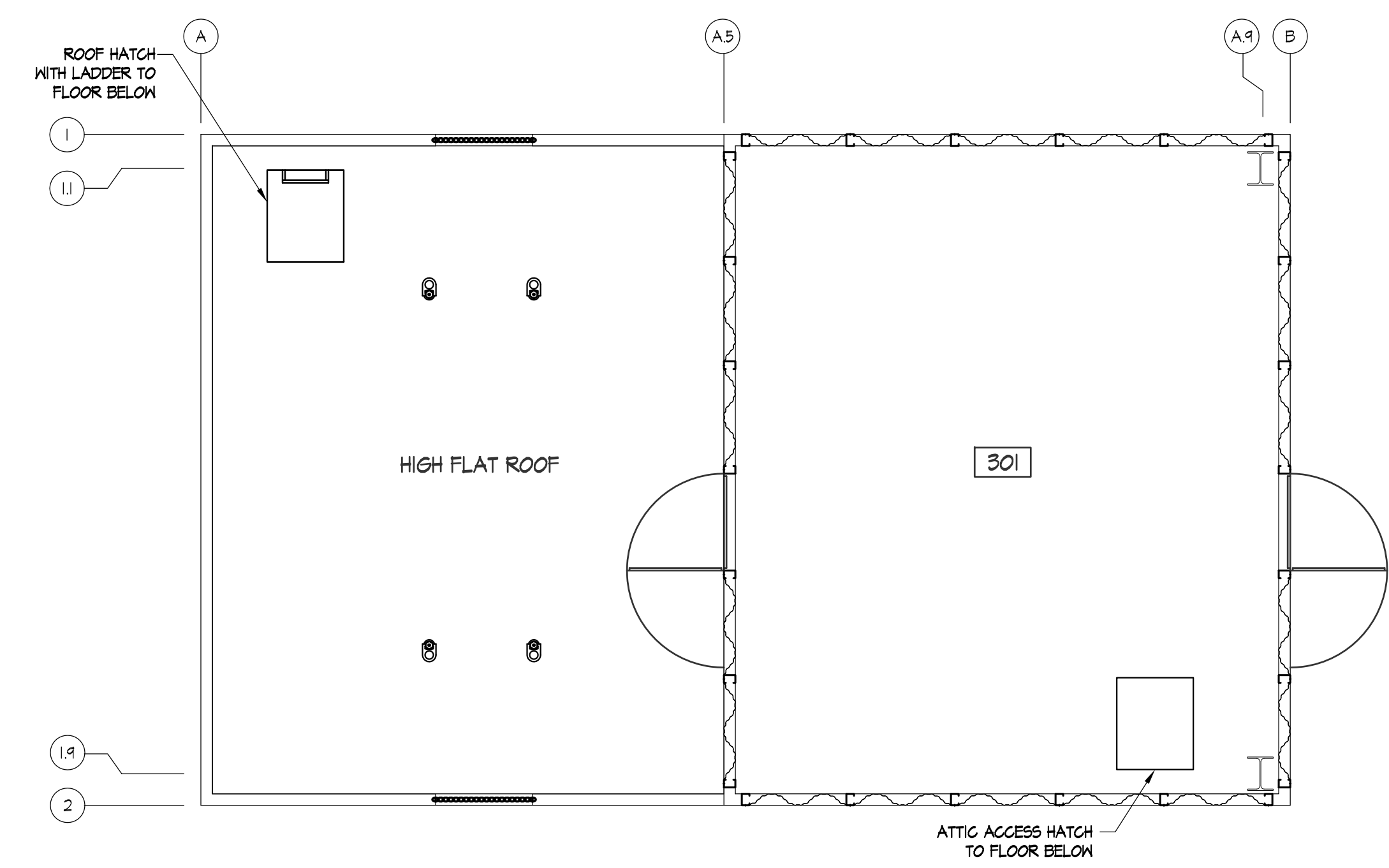

ATTIC FLOOR MECHANICAL PLAN
SCALE: 1/4" = 1'-0"

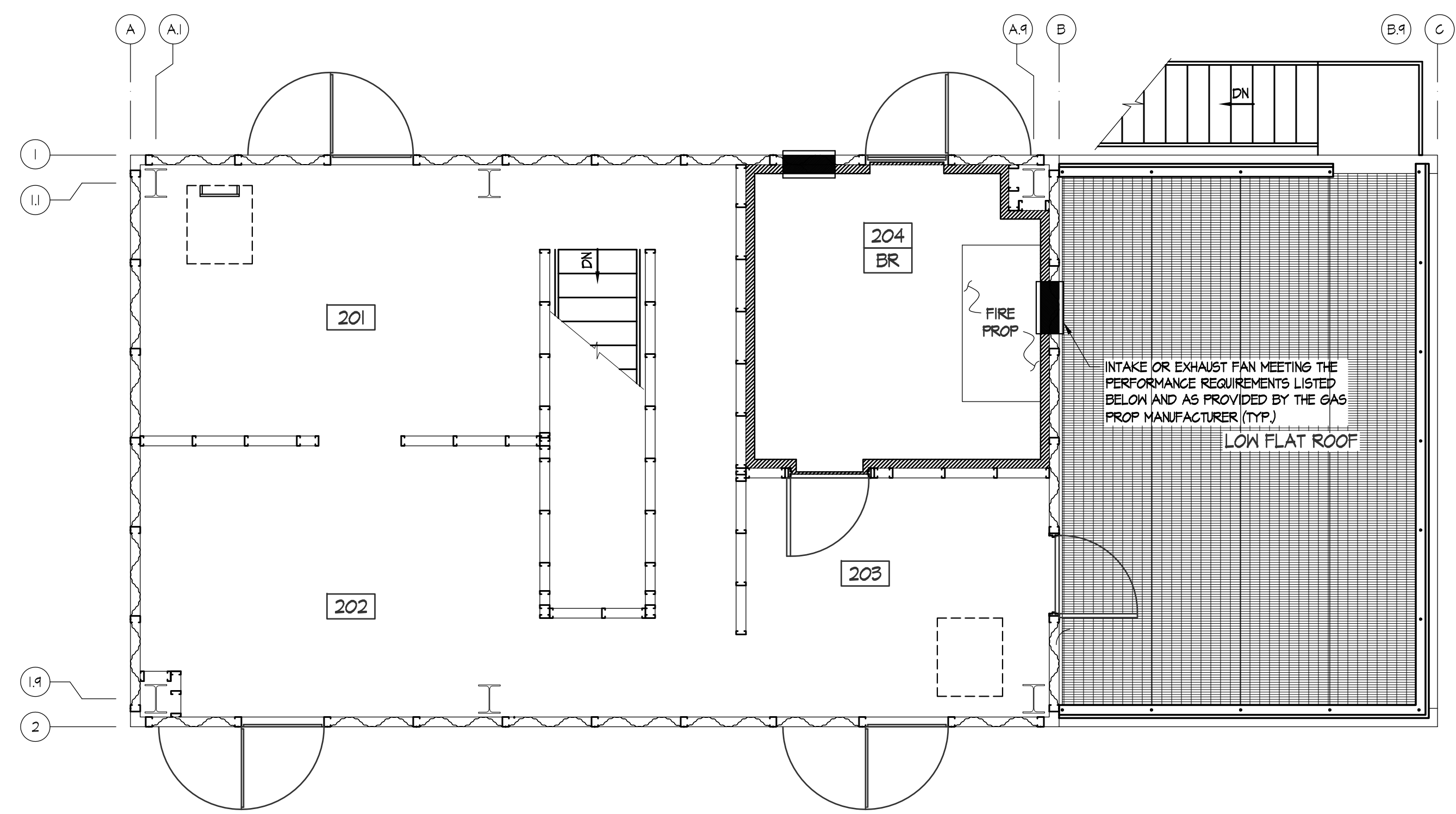

SECOND FLOOR MECHANICAL PLAN
SCALE: 1/4" = 1'-0"

NOTES

1. THE AUTOMATED FIRE TRAINING SYSTEM SHALL BE EQUIPPED WITH A VENTILATION SYSTEM TO REMOVE EXCESS HEAT, COMBUSTION BY-PRODUCTS, AND UNBURNED GAS FROM EACH TRAINING COMPARTMENT WITHIN THE BUILDING AND VENTILATION SYSTEM SHALL BE DESIGNED TO FULLY PURGE EACH TRAINING COMPARTMENT AT THE RATE OF ONE (1) AIR CHANGE PER MINUTE AS PER NFPA 1403. THE LIVE FIRE TRAINING SYSTEM SHALL CONTROL THE OPERATION AND MONITOR THE AIRFLOW OF THE VENTILATION SYSTEM IN THE BURN BUILDING. THE VENTILATION SYSTEM SHALL ONLY BE ACTIVATED DURING THE FOLLOWING CONDITIONS:
 - A) TO FULLY PURGE THE TRAINING COMPARTMENTS AT POWER UP.
 - B) TO FLUSH THE BURN BUILDING PRIOR TO TRAINING.
 - C) TO FULLY PURGE THE TRAINING COMPARTMENTS WHEN EXCESSIVE GAS OR TEMPERATURE LEVELS ARE DETECTED DURING TRAINING.
2. THE FIRE TRAINING SYSTEM SHALL HAVE A COMPARTMENT TEMPERATURE DETECTION SENSOR THAT MONITORS TEMPERATURES AT 5' A.F.F. IF TEMPERATURES IN THE TRAINING COMPARTMENT EXCEED 550° THE VENTILATION SYSTEM SHALL RUN. IF TEMPERATURES AT THE 5' LEVEL EXCEED 700°, THE SYSTEM SHALL SHUTDOWN AND THE VENTILATION SYSTEM SHALL RUN UNTIL TEMPERATURES ARE REDUCED.
3. THE FIRE TRAINING SYSTEM SHALL HAVE A HARD-WIRED EMERGENCY SHUTDOWN CIRCUIT THROUGHOUT THE FACILITY TO PROVIDE WIDESPREAD ACCESS TO SHUTDOWN (E-STOP) PUSH BUTTONS. E-STOP PUSH BUTTONS SHALL BE LOCATED AT THE ENTRANCE(S) TO EACH TRAINING COMPARTMENT, ON THE SCENARIO CONTROL ASSEMBLIES, AND ON EACH CONTROL PENDANT. THE EFFECT OF PUSHING ANY E-STOP BUTTON SHALL CAUSE ALL BURNER CONTROL VALVES TO CLOSE, FACILITY GAS SUPPLY TO BE SECURED AND SMOKE PRODUCTION TO STOP. VENTILATION FANS WILL AUTOMATICALLY RUN AT MAXIMUM ONCE THE E-STOP PUSH BUTTON HAS BEEN ACTIVATED. THE VENTILATION SYSTEM WILL RUN CONTINUOUSLY AT MAXIMUM LEVEL UNTIL THE E-STOP HAS BEEN MANUALLY RESET AND SAFE OPERATING CONDITIONS EXIST.
4. THE FIRE TRAINING SYSTEM SHALL HAVE A GAS DETECTION SYSTEM WHICH CONTINUALLY MONITORS UNBURNED GLASS 'B' FUEL LEVELS IN THE TRAINING COMPARTMENTS AND ANY EQUIPMENT ROOMS WHERE GLASS 'B' FUEL LINES ARE INSTALLED. A MINIMUM OF TWO (2) GAS SENSORS SHALL BE SUPPLIED PER TRAINING COMPARTMENT. IF GAS LEVELS REACH 10% LEL, THE VENTILATION SYSTEM SHALL RUN. IF GAS LEVELS REACH 25% LEL, THE VENTILATION SYSTEM SHALL RUN AT MAXIMUM SPEED AND ALL GAS VALVES SHALL CLOSE. THE VENTILATION SYSTEM SHALL CONTINUOUSLY RUN UNTIL GAS LEVELS ARE REDUCED BELOW 10% LEL.
5. THE FIRE TRAINING SYSTEM FUEL CONTROL ASSEMBLY SHALL CONNECT TO THE GLASS 'B' FUEL SUPPLY LINE. THE FUEL CONTROL ASSEMBLY SHALL CONSIST OF BOTH HIGH AND LOW PRESSURE SWITCHES. THE LINE PRESSURE SHALL BE MONITORED FOR ABNORMAL CONDITIONS AND SHALL SHUT DOWN THE SYSTEM IF THE LINE PRESSURE IS TOO HIGH OR TOO LOW. SHOULD A HIGH-PRESSURE CONDITION EXIST, THE VENTILATION SYSTEM SHALL START AND AN EMERGENCY SHUTDOWN SHALL OCCUR.
6. A MINIMUM OF TWO (2) EXTINGUISHING AGENT SENSORS SHALL BE LOCATED IN EACH BURN ROOM WITH ONE (1) DIRECTLY WITHIN THE BURN PROP. THE OUTPUT OF THESE SENSORS SHALL BE UTILIZED BY THE INSTRUCTOR TO DETERMINE THE EFFECTIVENESS OF AGENT APPLICATION WITH REGARD TO RATE AT WHICH FIRE IS EXTINGUISHED.
7. ALL COMPONENTS IN THIS SYSTEM SHALL PERFORM WITHIN THE FOLLOWING MINIMUM STANDARDS:
 - A) CONTROL ROOM EQUIPMENT:
 - TEMPERATURE: 65 TO 85° F (OPERATING)
 - 20 TO 125° F (STORAGE)
 - HUMIDITY: 0 TO 45% (NON-CONDENSING)
 - B) OUTDOOR EQUIPMENT:
 - TEMPERATURE: 20 TO 100° F (OPERATING)
 - 20 TO 125° F (STORAGE)
 - HUMIDITY: 0 TO 100%
 - C) COMPARTMENT EQUIPMENT:
 - TEMPERATURE: 32° F TO MAX. (OPERATING)
 - 20 TO 125° F (STORAGE)
 - HUMIDITY: 0 TO 100%
 - D) MECHANICAL: ALL TRAINING COMPARTMENT EQUIPMENT SHALL WITHSTAND DIRECT HOSE PRESSURE OF 100 PSI AT 150 GPM FROM A DISTANCE OF THREE (3) FEET.
 - E) TOTAL TRAINING SYSTEM: MTF (MEAN TIME BETWEEN FAILURES) > 500 HOURS (OPERATING).
 - F) MTR (MEAN TIME TO REPAIR) < 30 MINUTES (WHEN REPAIRS ARE PERFORMED BY QUALIFIED SERVICE PERSONNEL).

PRIME PROFESSIONAL FIRM LOGO

Project Title
**COMMONWEALTH OF VIRGINIA
BURN BUILDING PROP
PROTOTYPE 2
CLASS B FUEL**

SUB-CONSULTANT'S LOGO



Department of Fire Programs

NOT FOR CONSTRUCTION

THESE DRAWINGS ARE OWNED BY THE COMMONWEALTH OF VIRGINIA © 2013

No.	REVISIONS	Date

Sheet Title
MECHANICAL PLANS & NOTES

CITY/COUNTY: VIRGINIA
 Drawn By: SJS Approved By: MAM
 Checked By: SMF Date: 04/11/13

PROFESSIONAL SEAL

Sheet No.
M1.0
18 of 18

Chapter 7

DESIGN-BUILD (“D/B”) PROCEDURES

In accordance with the provisions of Chapter 43.1 Construction Management and Design-Build Contracting, being § 2.2-4378 et seq. (the “D-B Code Requirements”), of the Code of Virginia (1950, as amended) (“Code”), and consistent with the procedures adopted by the Secretary of Administration utilizing Design-Build, the Fluvanna County Board of Supervisors hereby adopts the following procedures for the procurement of Design-Build (“D/B”) contracts, as defined in § 2.2-4379, which shall be followed by the County of Fluvanna, Virginia (“County”).

7-1. LEGISLATIVE AUTHORITY

7-1.1. Generally: Section 2.2-4300 et seq. the Virginia Public Procurement Act and Section 2.2-4378 et seq. Construction Management and Design-Build Contracting, and specifically:

Section 2.2-4301 and 2.2-4379: Definitions of design-build contract and other key terms;
Section 2.2-4303(D)(4): Exceptions to competitive sealed bidding;
Section 2.2-4378 Purpose; applicability;
Section 2.2-4382 Design-Build Procedures for local public bodies; and
Section 2.2-4383 Reporting Requirements for all Public Bodies relating to design build contracting

Any reference in these D-B Procedures to the Code of Virginia or other relevant Federal, State or local law is incorporated in whole herein by reference as in effect at the time of the Solicitation or Contract as such statutory provisions may be amended or replaced by any statute dealing with the same or similar subject matter.

7-2. GENERAL

7-2.1. A design-build contract is a contract between a public body and another party in which the party contracting with the public body agrees to both design and build the structure, roadway or other item specified in the contract. The County may contract to secure D-B projects on a fixed price or not-to-exceed price basis in accordance with *Virginia Code* § 2.2-4382(A), the requirements of that section and the D-B Code Requirements, and the procedures adopted by the Virginia Secretary of Administration for utilizing design-build or construction management contracts. The County is authorized to use competitive negotiations to procure D-B contracts when it determines in advance, and sets forth in writing, that competitive sealed bidding is not practicable or fiscally advantageous to the public, which writing shall document the basis for this determination.

7-3. PROCEDURE FOR APPROVAL

7-3.1. Prior to making a determination as to the use of design-build or construction management for a specific construction project, the public body shall have in its employ or under contract a licensed architect or engineer with professional competence appropriate to the project who shall advise the public body regarding the use of design-build or construction management for that project and who shall assist the public body with the preparation of the Request for Proposal and

the evaluation of such proposals.

7-3.2. Prior to taking any action, the County shall request authority, in writing and receive approval from the Board of Supervisors, to use a D-B contract. The request shall justify and substantiate that D-B is more advantageous than a competitive sealed bid construction contract with a general contractor and shall indicate how the County will benefit from using D-B. The request shall also include a written justification that sealed bidding is not practicable and/or fiscally advantageous. These justifications for the use of D-B shall be stated in the Request for Proposals.

7-4. GENERAL PROCEDURES

7-4.1. The D-B procurement shall be consistent with the procurement of nonprofessional services through competitive negotiation and shall also require Requests for Proposals to include and define the criteria of such construction project in areas such as site plans; floor plans; exterior elevations; basic building envelope materials; fire protection information plans; structural, mechanical (HVAC), and electrical systems; and special telecommunications; and may define such other requirements as the County determines appropriate for that particular construction project. Design-build construction projects shall include a two-step competitive negotiation process consistent with the standards established by the Division of Engineering and Buildings of the Department of General Services for state agencies.

The County shall appoint an Evaluation Committee (“Committee”) which shall consist of at least three members from the County, including a licensed design professional, if possible. In addition to the County members, the Committee shall include a licensed professional engineer or architect. The County shall contact the County Attorney’s Office (CAO) to determine whether a representative from the CAO should be involved.

7-5. SELECTION PROCEDURES

7-5.1. On projects approved for D-B, procurement of the contract shall be a two-step competitive negotiation process. The following procedures shall be used in selecting a design build contractor and awarding a contract:

7-5.1.1. Selection of Qualified Offerors (STEP I): On projects approved for D-B, the County shall conduct a prequalification process as follows to determine which offerors are qualified to receive Request for Proposals (RFPs).

a. The County shall prepare a Request for Proposals (“RFP”) containing the County's Facility Requirements, building and site criteria, site and survey data (if available), the criteria to be used to evaluate RFP Responses and other relevant information, including any unique capabilities or qualifications that will be required of the contractor. All offerors shall have a licensed Class “A” contractor and an Architect or Engineer registered in the Commonwealth of Virginia as part of the Project Team.

b. The RFP shall be posted in accordance with the current standards for the posting

of public bids in the Virginia Code and in accordance with the latest edition of the Construction and Professional Services Manual.

c. The Committee shall evaluate each offeror's RFP responses and any other relevant information and shall determine which offerors are fully qualified and suitable for the project.

d. The RFP evaluation shall result in a short list of two to five offerors to receive the RFP. An offeror may be denied prequalification only as specified under Virginia Code § 2.2-4317, but the short list shall also be based upon the RFP criteria.

e. At least 30 days prior to the date established for the submission of proposals, the County shall advise in writing each offeror which sought prequalification whether that offeror has been prequalified. Prequalified offerors that are not selected for the short list shall likewise be provided the reasons for such decision. In the event that an offeror is denied prequalification, the written notification to such offeror shall state the reasons for such denial of prequalification and the factual basis of such reasons.

7-5.1.2. Selection of Design Build Contractor (STEP II):

a. The County shall send an RFP to the design build offerors on the short list for the project and request formal proposals from them. The criteria for award shall be included in the RFP.

b. Sealed Technical Proposals as described in the RFP shall be submitted to the Committee. Separately-sealed Cost Proposals shall be submitted to the County's Purchasing Agent, and shall be secured by and kept sealed until evaluation of the Technical Proposals and the design adjustments are completed.

c. The Committee will evaluate the Technical Proposals based on the criteria contained in the RFP. It will inform each D-B offeror of any adjustments necessary to make its Technical Proposal fully comply with the requirements of the RFP. In addition, the County may require that offerors make design adjustments necessary to incorporate project improvements and/or additional detailed information identified by the Committee during design development.

d. Based on the adjustments made to the Technical Proposals, the offeror may amend its Cost Proposal. In addition, an offeror may submit cost modifications to its original sealed Cost Proposal which are not based upon revisions to the Technical Proposals.

e. The Committee shall evaluate (and rank if technical rankings are to be considered as a criteria for award) the technical proposals. Should the County determine in writing and in its sole discretion that only one offeror is fully qualified, or that one offeror is clearly more highly qualified than the others under consideration, a contract may be negotiated and awarded to that offeror after approval of the purchasing agent. Otherwise, the County shall open the cost proposals and apply the criteria for award as specified in the RFP and approved by the purchasing agent.

f. The Committee shall make its recommendation for the selection of a design build contractor to the County head based on its evaluations of the technical and cost proposals and all amendments thereto. The contract shall be awarded to the offeror who is fully qualified and has been determined to have provided the best value in response to the Request for Proposal.

g. The County shall notify the Board of Supervisors and the County's Purchasing Agent of its selection of the Design build contractor and shall request authority to award a contract by processing the notice of award and providing supporting documents, to the purchasing division via e-mail.

h. The County will notify all offerors who submitted proposals which offeror was selected for the project. In the alternative, the County may notify all offerors who submitted proposals of the County's intent to award the contract to a particular offeror at any time after the County head has selected the Design build contractor. When the terms and conditions of multiple awards are so provided in the RFP, awards may be made to more than one offeror.

i. Upon request, documentation of the process used for the final selection shall be made available to the unsuccessful proposers.

7-6. Basis of Award

7-6.1. The basis of the award of the contract shall be in accordance with applicable law including without limitation the D-B Code Requirements and the criteria for the award shall be submitted to the Purchasing Agent, in advance, for approval. It is noted that cost is a critical component of the selection process. Guidance on methods for award can be found in the Construction and Professional Services Manual (2012 Edition, as amended) Section 7.30.1.